

H8170 Parts Breakdown - Main Assembly

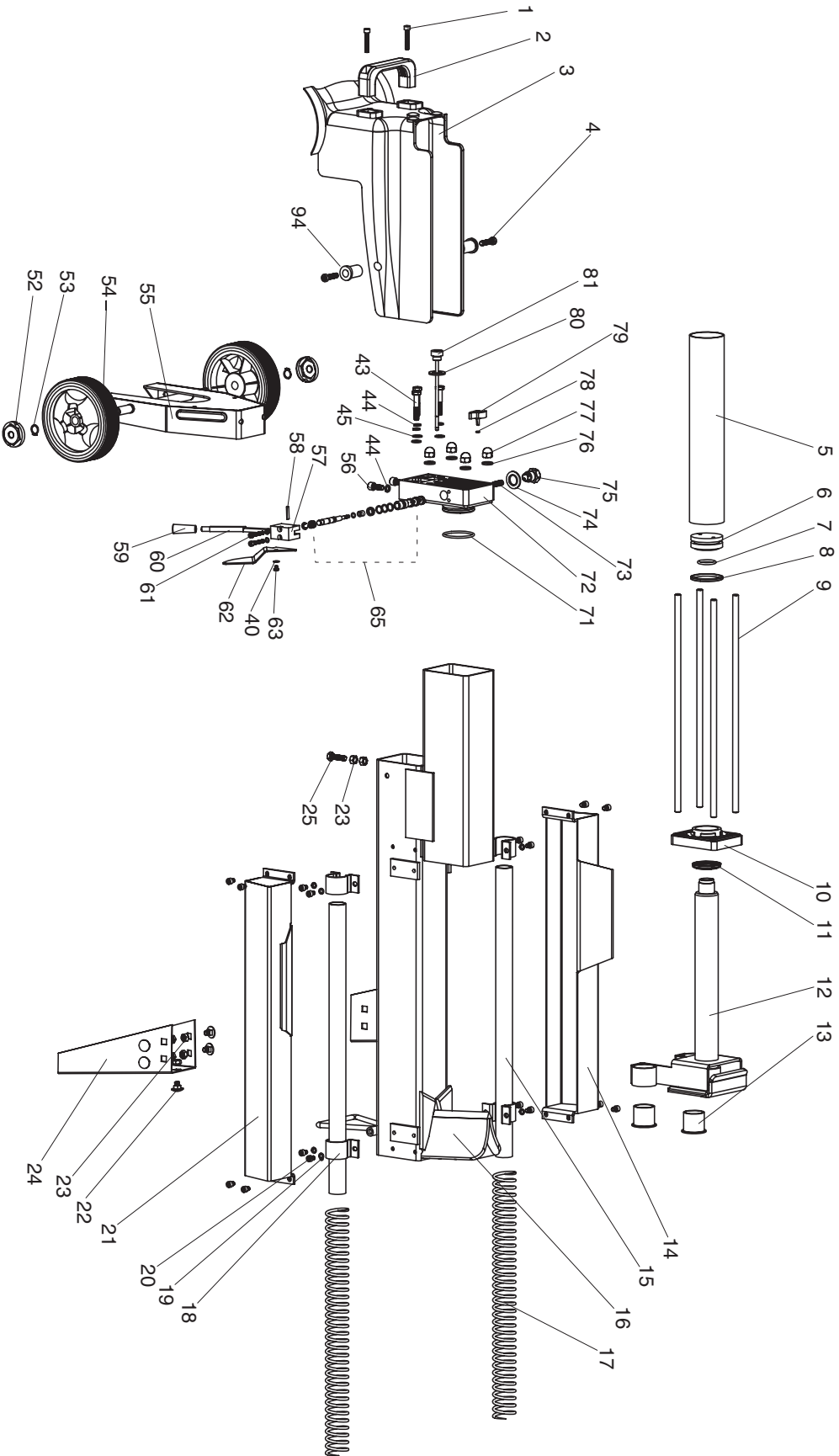

H8170 Parts List

REF	PART #	DESCRIPTION
1	PCAP28M	CAP SCREW M6-1 X 15
2	PH8170002	REAR LIFTING HANDLE
3	PH8170003	PLASTIC HOOD
4	PCAP14M	CAP SCREW M8-1.25 X 20
5	PH8170005	HYDRAULIC CYLINDER
6	PH8170006	PISTON
7	PH8170007	PISTON RING 5.5MM
8	PH8170008	PISTON SEAL 25 X 3.55MM
9	PH8170009	STUD-DE M10-1.5 X 383 34/34
10	PH8170010	FRONT CYLINDER COVER
11	PH8170011	PISTON GASKET
12	PH8170012	PISTON ROD 12"
13	PH8170013	NYLON SLEEVE
14	PH8171014	LEFT SPRING GUARD
15	PH8171015	SPRING ROD
16	PH8171016	BED ASSEMBLY
17	PH8171017	RETRACTING SPRING
18	PH8170018	SPRING HOOD BRACKET
19	PLW03M	LOCK WASHER 6MM
20	PCAP04M	CAP SCREW M6-1 X 10
21	PH8170021	RIGHT SPRING GUARD
22	PCB02M	CARRIAGE BOLT M8-1.25 X 10
23	PN03M	HEX NUT M8-1.25
24	PH8170024	SUPPORT LEG
25	PB26M	HEX BOLT M8-1.25 X 30
40	PW02M	FLAT WASHER 5MM
43	PB93M	HEX BOLT M5-.8 X 30

REF	PART #	DESCRIPTION
44	PLW04M	LOCK WASHER 8MM
45	PW01M	FLAT WASHER 8MM
52	PH8170052	WHEEL CAP
53	PR03M	EXT RETAINING RING 12MM
54	PH8170054	WHEEL
55	PH8170055	WHEEL AXLE FRAME
56	PB26M	HEX BOLT M8-1.25 X 30
57	PH8170057	REAR BRACKET
58	PH8170058	SHAFT
59	PH8170059	LEVER KNOB
60	PH8170060	HYDRAULIC LEVER
61	PH8170061	HYDRAULIC LEVER SCREW
62	PH8170062	HYDRAULIC LEVER GUARD
63	PH8170063	LEVER GUARD SCREW
65	PH8170065	VALVE CONTROL ASSEMBLY
71	PH8170071	RUBBER SEAL
72	PH8170072	ALUMINUM COVER
73	PH8170073	COMPRESSION SPRING
74	PH8170074	O-RING
75	PH8170075	SCREW PLUG
76	PH8170076	COPPER GASKET
77	PN18M	ACORN NUT M8-1.25
78	PH8170078	O-RING
79	PH8170079	BLEED SCREW
80	PH8170080	O-RING
81	PH8170081	DIPSTICK
94	PH8170094	RUBBER SLEEVE



H8170/H8171 Parts Breakdown

Motor Assembly

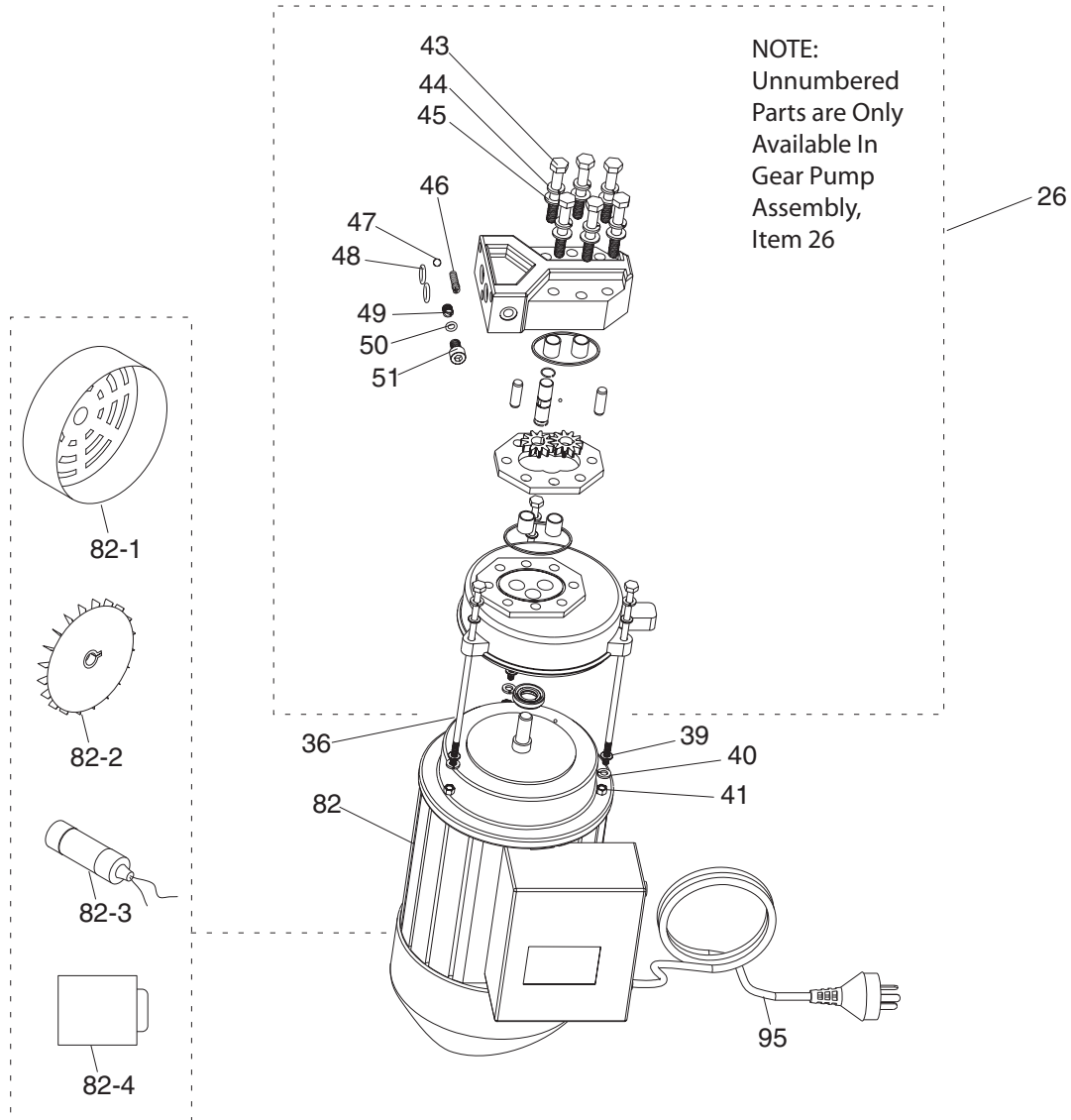

REF	PART #	DESCRIPTION
26	PH8170026	COMPLETE GEAR PUMP ASSY
36	PB93M	HEX BOLT M5-.8 X 30
39	PLW01M	LOCK WASHER 5MM
40	PW02M	FLAT WASHER 5MM
41	PN06M	HEX NUT M5-.8
43	PB93M	HEX BOLT M5-.8 X 30
44	PLW04M	LOCK WASHER 8MM
45	PW01M	FLAT WASHER 8MM
46	PH8170046	COMPRESSION SPRING
47	PH8170047	STEEL BALL

REF	PART #	DESCRIPTION
48	PH8170048	O-RING
49	PH8170049	SCREW
50	PH8170050	O-RING
51	PH8170051	DRAIN PLUG
82	PH8170082	MOTOR 1-3/4HP 110V 1PH
82-1	PH8170082-1	MOTOR FAN COVER
82-2	PH8170082-2	MOTOR FAN
82-3	PH8170082-3	S CAPACITOR 60M 300V
82-4	PH8170082-4	PUSH BUTTON SWITCH
95	PH8171095	POWER CORD 14G 3W 5-15



H8170/H8171 Safety Label Parts List

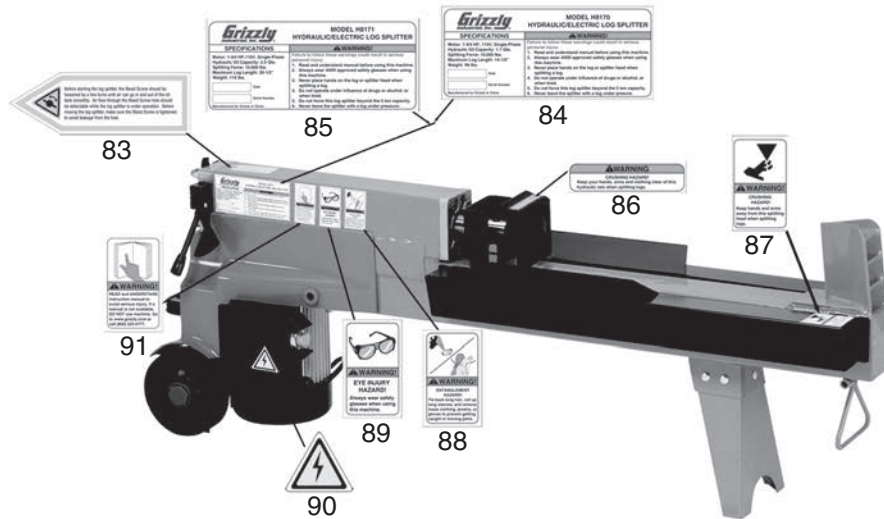

REF	PART #	DESCRIPTION
83	PH8170083	BLEEDER SCREW LABEL
84	PH8170084	MACHINE ID LABEL (H8170)
85	PH8171084	MACHINE ID LABEL (H8171)
86	PH8170086	CRUSHING HAZARD LABEL 1
87	PH8170087	CRUSHING HAZARD LABEL 2

REF	PART #	DESCRIPTION
88	PLABEL-55	ENTANGLEMENT HAZARD 2W X 3.3H
89	PLABEL-11A	SAFETY GLASSES 2W X 3.3H V2.04.08
90	PLABEL-14	ELECTRICITY 1.4W X 1.2H
91	PLABEL-12A	READ MANUAL 2W X 3.3H V2.07.05

WARNING

Safety labels warn about machine hazards and ways to prevent injury. The owner of this machine **MUST** maintain the original location and readability of the labels on the machine. If any label is removed or becomes unreadable, **REPLACE** that label before using the machine again. Contact Grizzly at (800) 523-4777 or www.grizzly.com to order new labels.

