

Parts Breakdown

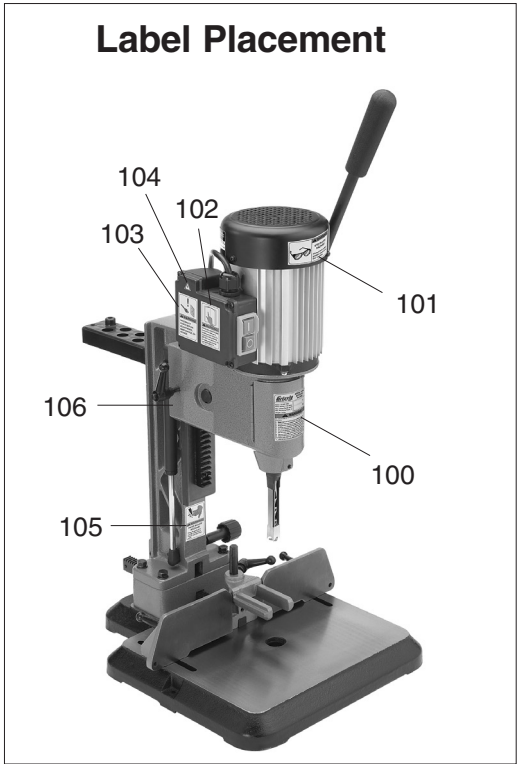
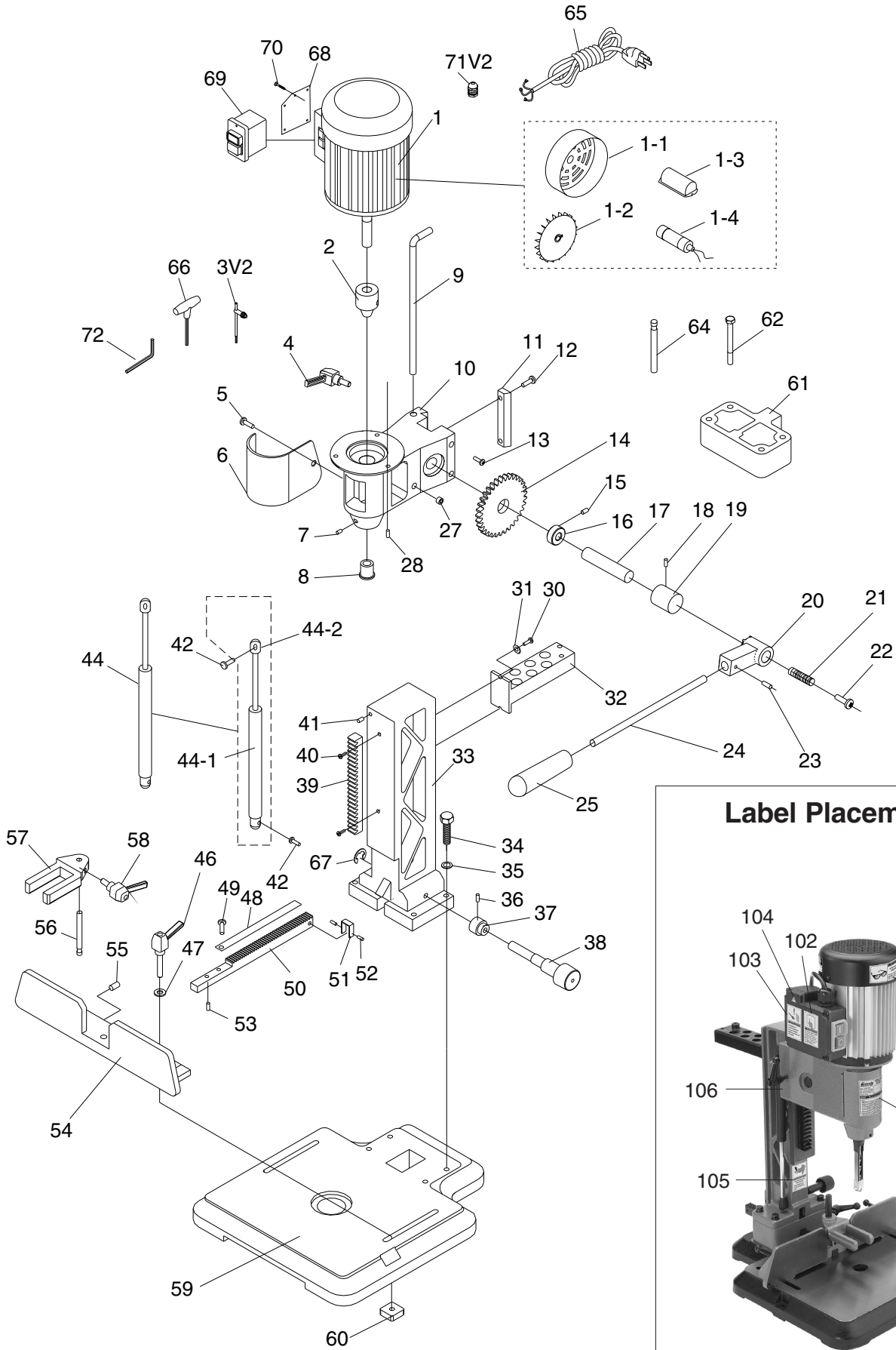

Parts List

REF	PART #	DESCRIPTION
1	P0645001	MOTOR 1/2 HP 110V
1-1	P0645001-1	FAN COVER
1-2	P0645001-2	FAN
1-3	P0645001-3	CAPACITOR COVER
1-4	P0645001-4	R CAPACITOR 25M 300V 2-7/8 X 1-3/8
2	P0645002	CHUCK JT#2 0-3/8"
3V2	P0645003V2	DRILL CHUCK KEY 1/4" STD 12T SD-5/8" V2
4	P0645004	LOCK LEVER M8-1.25 X 20
5	PS07M	PHLP HD SCR M4-.7 X 8
6	P0645006	CHUCK ACCESS COVER
7	PSS09M	SET SCREW M8-1.25 X 20
8	P0645008	BUSHING
9	P0645009	DEPTH STOP ROD
10	P0645010	HEADSTOCK
11	P0645011	DOVETAIL GIB
12	PSB14M	CAP SCREW M8-1.25 X 20
13	PS39M	PHLP HD SCR M8-1.25 X 10
14	P0645014	GEAR
15	P0645015	SET SCREW M5-.8 X 10
16	P0645016	SPACER
17	P0645017	SHAFT
18	PRP08M	ROLL PIN 6 X 30
19	P0645019	CLUTCH
20	P0645020	CLUTCH COLLAR
21	P0645021	COMPRESSION SPRING
22	P0645022	SHOULDER BOLT M10-1.5 X 15
23	PRP07M	ROLL PIN 6 X 20
24	P0645024	HANDLE
25	P0645025	RUBBER GRIP
27	P0645027	MAGNET
28	PSB24M	CAP SCREW M5-.8 X 16
30	PS11M	PHLP HD SCR M6-1 X 16
31	PW03M	FLAT WASHER 6MM
32	P0645032	TOOL STORAGE RACK
33	P0645033	COLUMN ASSEMBLY
34	PB07M	HEX BOLT M8-1.25 X 25
35	PW01M	FLAT WASHER 8MM

REF	PART #	DESCRIPTION
36	PSS09M	SET SCREW M8-1.25 X 20
37	P0645037	GEAR
38	P0645038	FENCE ADJUSTMENT KNOB
39	P0645039	COLUMN RACK
40	PSB28M	CAP SCREW M6-1 X 15
41	P0645041	ALIGNMENT PIN
42	P0645042	BALL END
44	P0645044	GAS SPRING ASSEMBLY
44-1	P0645044-1	CYLINDER
44-2	P0645044-2	COLUMN ADAPTER
46	P0645046	LOCK LEVER M8-1.25 X 50
47	PW01M	FLAT WASHER 8MM
48	P0645048	DUST COVER 10 X 5/8 (METAL)
49	PS05M	PHLP HD SCR M5-.8 X 8
50	P0645050	FENCE ADJUSTMENT RACK
51	P0645051	BRACKET
52	PSS16M	SET SCREW M8-1.25 X 10
53	PSS09M	SET SCREW M8-1.25 X 20
54	P0645054	FENCE
55	PSS16M	SET SCREW M8-1.25 X 10
56	P0645056	SHORT HOLD DOWN ROD 104MM
57	P0645057	HOLD DOWN
58	P0645058	LOCK LEVER M8-1.25 X 20
59	P0645059	BASE
60	PSN03M	SQUARE NUT M8-1.25
61	P0645061	EXTENSION BLOCK
62	PB82M	HEX BOLT M8-1.25 X 80
64	P0645064	LONG HOLD DOWN ROD 145MM
65	P0645065	POWER CORD 18AWG X 3C
66	P0645066	T-HANDLE HEX WRENCH 4MM
67	PEC07M	E-CLIP 7MM
68	P0645068	SWITCH COVER
69	P0645069	ON/OFF SWITCH KJD20-6F/110V
70	PHTEK31M	TAP SCREW M4 X 14
71V2	P0645071V2	STRAIN RELIEF TYPE 3 M16-1.5 V2
72	PAW08M	HEX WRENCH 8MM

Label Placement

REF	PART #	DESCRIPTION
100	P0645100	ID LABEL
101	P0645101	SAFETY GLASSES LABEL 2-3/4" X 1-1/2"
102	P0645102	READ MANUAL LABEL 1-1/2" X 2-1/2"
103	P0645103	DISCONN POWER LABEL 1-1/2" X 2-1/2"

REF	PART #	DESCRIPTION
104	PLABEL-14	ELECTRICITY LABEL
105	P0645105	HAND INJURY LABEL 1-1/2" X 2-1/2"
106	PPAINT-1	GRIZZLY GREEN TOUCH UP PAINT

WARNING

Safety labels warn about machine hazards and ways to prevent injury. The owner of this machine **MUST** maintain the original location and readability of the labels on the machine. If any label is removed or becomes unreadable, **REPLACE** that label before using the machine again. Contact Grizzly at (800) 523-4777 or www.grizzly.com to order new labels.

