

# READ THIS FIRST



Model G0609X

**\*\*\*IMPORTANT UPDATE\*\*\***

For Machines Mfd. Since 04/15  
and Manual Insert Revised 07/08

For questions or help with this product contact Tech Support at (570) 546-9663 or [techsupport@grizzly.com](mailto:techsupport@grizzly.com)

The following changes were recently made to this machine since the manual insert was printed:

- Changed spiral cutterhead and indexable inserts.

Aside from this information, all other content in the owner's manual applies and **MUST** be read and understood for your own safety. **IMPORTANT: Keep this update with the owner's manual for future reference.**

For questions or help, contact our Tech Support at (570) 546-9663 or [techsupport@grizzly.com](mailto:techsupport@grizzly.com).

## Revised Parts

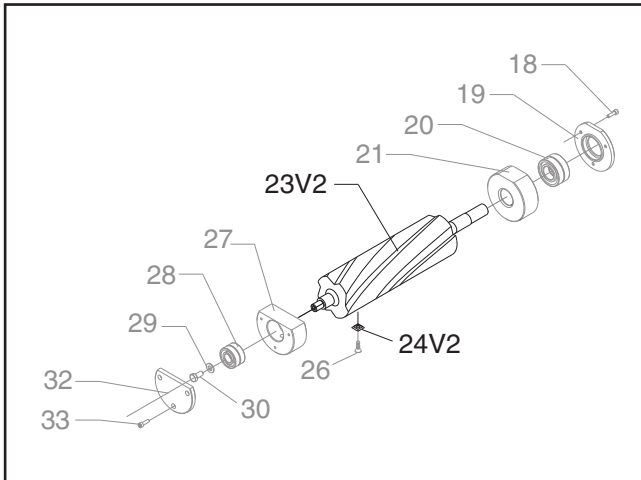

REF	PART #	DESCRIPTION
23V2	P0609X023V2	SPIRAL CUTTERHEAD 12" V2.04.15
24V2	P0609X024V2	INDEXABLE INSERT 14 X 14 X 2MM V2.04.15

COPYRIGHT © SEPTEMBER, 2015 BY GRIZZLY INDUSTRIAL, INC.  
**WARNING: NO PORTION OF THIS MANUAL MAY BE REPRODUCED IN ANY SHAPE  
OR FORM WITHOUT THE WRITTEN APPROVAL OF GRIZZLY INDUSTRIAL, INC.**  
#JH17636 PRINTED IN CHINA

# READ THIS FIRST



## Model G0609/G0609X

### \*\*\*IMPORTANT UPDATE\*\*\*

For Machines Mfg. Since August, 2012  
and Owner's Manual Revised February, 2008

The following changes were recently made to these machines since the owner's manual was printed:

- Obtained CSA certification for meeting CSA 22.2 #71.2-08 and UL 987-7th standards.
- Changed the motor nominal voltage from 220V to 230V on both models, changed the G0609 capacitor wiring, and added a power cord with a plug.
- Changed the cast iron V-belt pulleys to aluminum alloy versions designed for a ribbed serpentine V-belt.
- Stopped shipping the cutterhead guard pre-installed. The installation instructions below replace "Winding Cutterhead Guard" on **Page 17**. *You MUST install the guard before operating the first time!*

This document provides relevant updates to portions of the owner's manual that no longer apply and additional information required by CSA—aside from this information, all other content in the owner's manual applies and **MUST** be read and understood for your own safety. **IMPORTANT: Keep this update with the owner's manual for future reference.**

For questions or help, contact our Tech Support at (570) 546-9663 or [techsupport@grizzly.com](mailto:techsupport@grizzly.com).

## Cutterhead Guard Installation

1. DISCONNECT JOINTER FROM POWER!
2. Unthread the ends of the set screws shown in **Figure 1** so they are flush with the mounting hole.

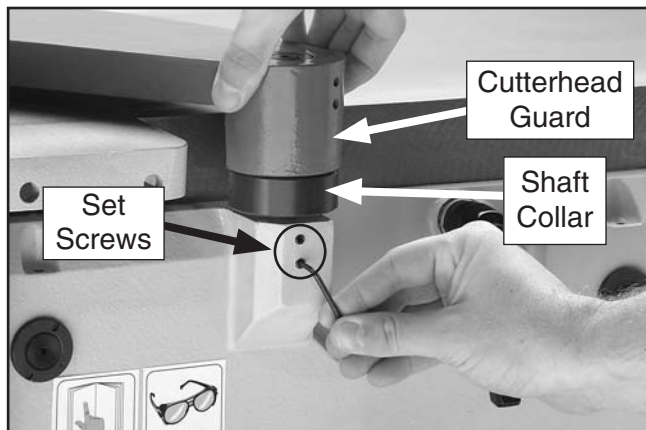

**Figure 1.** Installing cutterhead guard.

3. Insert the cutterhead guard shaft into the hole, then place the guard against the fence.
4. Insert a 3mm hex wrench into the shaft collar hole and wind the collar clockwise  $\frac{1}{4}$  turn.
5. While holding the shaft collar, tighten the set screws on the base (see **Figure 1**).
6. Pull the guard back and let it go. The guard should spring back over the cutterhead.

—If the guard drags across the table, loosen the set screws on the guard, raise it slightly, then tighten the set screws.

—If the guard does not spring back over the cutterhead, loosen the set screws on the base (see **Figure 1**), hold the guard over the cutterhead, wind the shaft collar clockwise, then tighten the set screws. See if the guard works, adjust the collar as needed.



COPYRIGHT © JUNE, 2011 BY GRIZZLY INDUSTRIAL, INC. REVISED AUGUST, 2012 (BL)

**WARNING: NO PORTION OF THIS MANUAL MAY BE REPRODUCED IN ANY SHAPE OR FORM WITHOUT THE WRITTEN APPROVAL OF GRIZZLY INDUSTRIAL, INC.**

#BL14232 PRINTED IN CHINA

# Changed Specifications

## Electrical

Power Requirement.....230V, Single-Phase, 60 Hz

## Motor

Voltage .....230V

## Operation Info

Cutterhead Speed ..... 4300 RPM

### New/Revised G0609 Parts

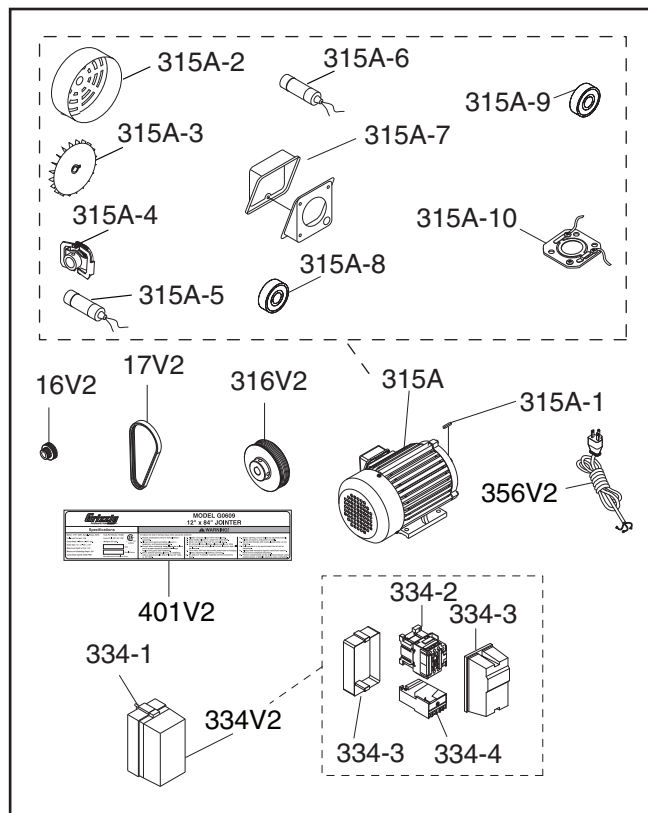

### New/Revised G0609X Parts

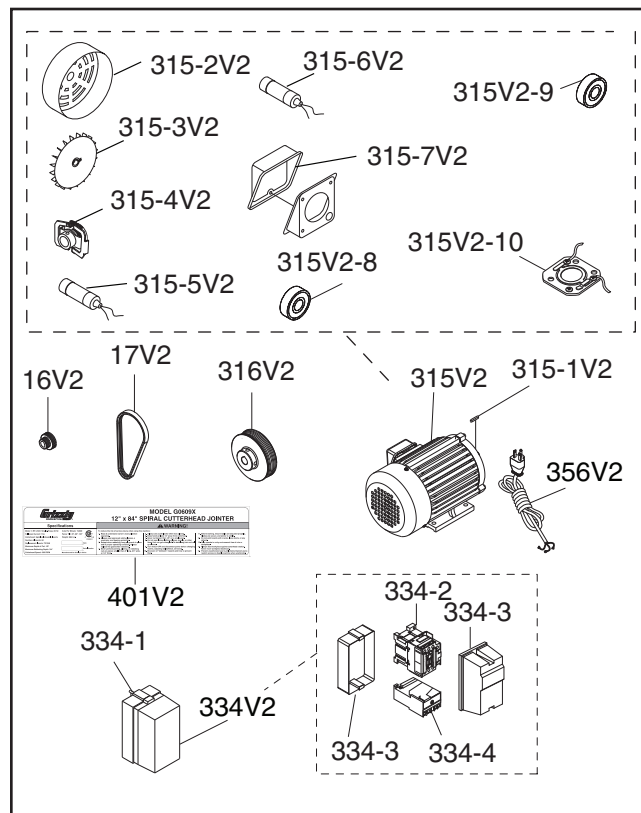

REF	PART #	DESCRIPTION
16V2	P0609016V2	ALUM CUTTERHEAD PULLEY V2.03.09
17V2	P0609017V2	RIBBED V-BELT 8PK-1371 V2.03.09
315A	P0453430A	MOTOR 3HP 230V 1-PH V2.03.08
315A-1	PK33M	KEY 5 X 5 X 45
315A-2	P0453430A-1	MOTOR FAN COVER V2.03.08
315A-3	P0453430A-2	MOTOR FAN V2.03.08
315A-4	P0453430A-9	CENTRIFUGAL SWITCH 16MM 3450
315A-5	P0453430A-5	S CAPACITOR 200M 250V V2.03.08
315A-6	P0453430A-4	R CAPACITOR 20M 400V V2.03.08
315A-7	P0453430A-6	JUNCTION BOX V2.03.08
315A-8	P6205ZZ	BALL BEARING 6205ZZ
315A-9	P6203ZZ	BALL BEARING 6203ZZ
315A-10	P0453430A-10	CONTACT PLATE 16MM
316V2	P0609316V2	ALUMINUM MOTOR PULLEY V2.03.09
334V2	P0609334V2	MAGNETIC SWITCH V2.01.11
334-1	PS06M	PHLP HD SCR M5-.8 X 20
334-2	P0609334-2	CONTACTOR NHD C-12D 230V
334-3	P0609334-3	MAG SWITCH COVER ASSEMBLY
334-4	P0609334-4	OL RELAY NHD NTH-17 14-17A
334-5	P0609334-3	MAG SWITCH COVER ASSEMBLY
356V2	P0453119V2	PWR CORD 12G 3W 72" 6-20P V2.08.12
401V2	P0609401V2	MACHINE ID LABEL CSA V2.08.12

REF	PART #	DESCRIPTION
16V2	P0609016V2	CUTTERHEAD PULLEY, ALUM V2.03.09
17V2	P0609017V2	RIBBED V-BELT 8PK-1371 V2.03.09
315V2	P0453Z518V2	MOTOR 3HP 230V 1-PH V2.05.08
315-1V2	PK33M	KEY 5 X 5 X 45
315-2V2	P0453Z518-1	MOTOR FAN COVER
315-3V2	P0453Z518-2	MOTOR FAN
315-4V2	P0609X315-4V2	CENTRIFUGAL SWITCH 16MM 3450
315-5V2	P0453Z518-3V2	S CAPACITOR 250M 250V 1-3/4 X 3-1/2
315-6V2	P0453Z518-4V2	R CAPACITOR 40M 450V 1-3/8 X 2-3/8
315-7V2	P0453Z518-5V2	JUNCTION BOX V2.05.08
315V2-8	P6205ZZ	BALL BEARING 6205ZZ
315V2-9	P6203ZZ	BALL BEARING 6203ZZ
315V2-10	P0453Z518-9	CONTACT PLATE 16MM
316V2	P0609316V2	ALUM MOTOR PULLEY V2.03.09
334V2	P0609334V2	MAGNETIC SWITCH V2.01.11
334-1	PS06M	PHLP HD SCR M5-.8 X 20
334-2	P0609334-2	CONTACTOR NHD C-12D 230V
334-3	P0609334-3	MAG SWITCH COVER ASSEMBLY
334-4	P0609334-4	OL RELAY NHD NTH-17 14-17A
334-5	P0609334-3	MAG SWITCH COVER ASSEMBLY
356V2	P0453119V2	PWR CORD 12G 3W 72" 6-20P V2.08.12
401V2	P0609X401V2	MACHINE ID LABEL CSA V2.08.12



# Jointer Breakdown

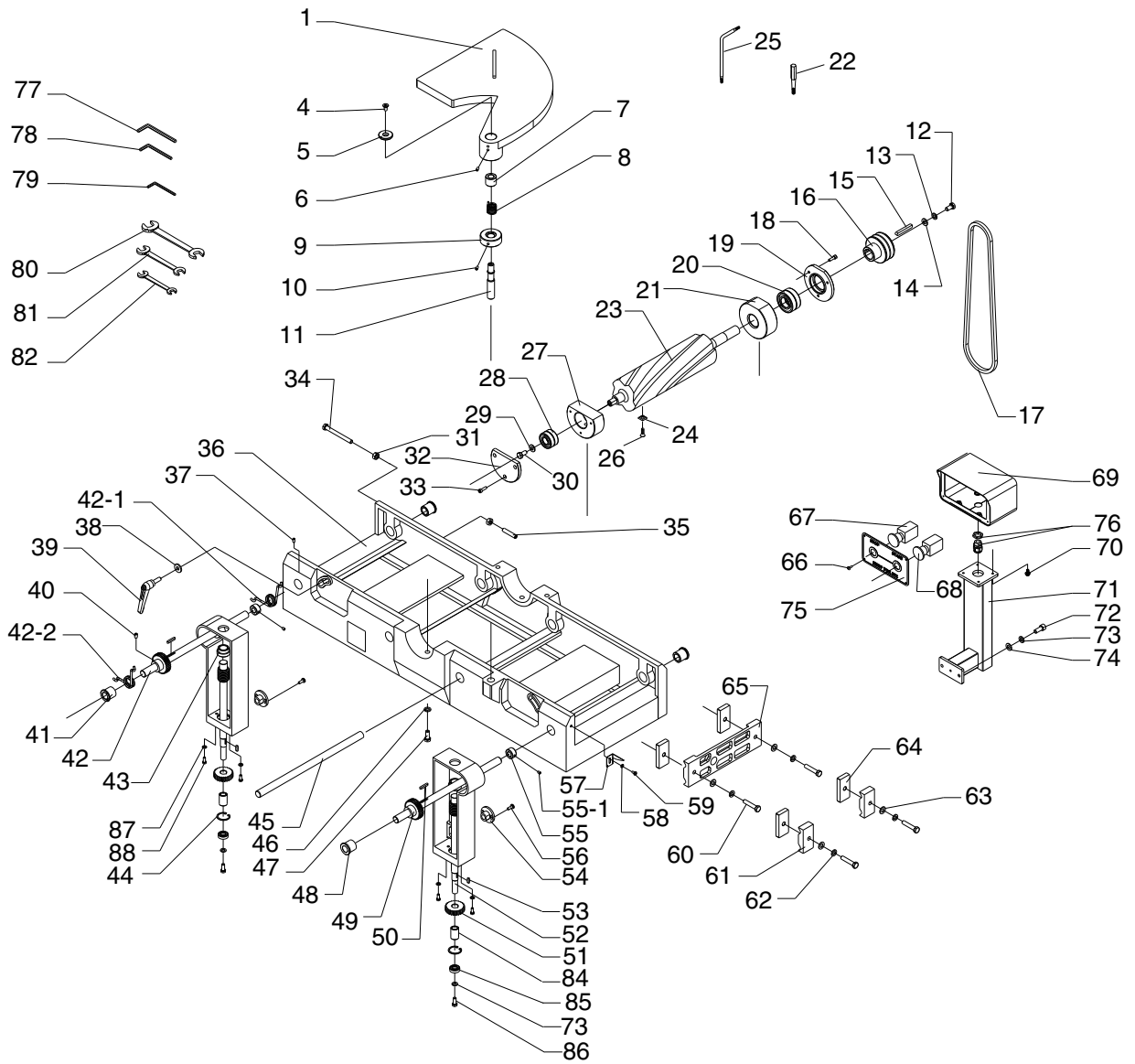

# Jointer Breakdown Parts List

REF	PART #	DESCRIPTION
1	P0609001	CUTTERHEAD GUARD
4	PFH23M	FLAT HD SCR M8-1.25 X 16
5	P0609005	SPECIAL FLAT WASHER
6	PSS04M	SET SCREW M6-1 X 12
7	P0609007	ADAPTER
8	P0609008	TORSION SPRING
9	P0609009	SHAFT COLLAR
10	PSS04M	SET SCREW M6-1 X 12
11	P0609011	SHAFT
12	P0609012	CUTTERHEAD SCREW
13	PLW06M	LOCK WASHER 10MM
14	PW04M	FLAT WASHER 10MM
15	PK111	KEY 8 X 8 X 60
16	P0609016	CUTTERHEAD PULLEY
17	PVA53	V-BELT A-53 4L530
18	PSB02M	CAP SCREW M6-1 X 20
19	P0609019	BEARING COVER
20	P6206	BALL BEARING 6206ZZ
21	P0609021	BEARING SUPPORT
22	P0452Z001	DRIVER BIT TORX T20
23	P0609X023	SPIRAL CUTTERHEAD 12"
24	P0452Z002	INDEXABLE INSERT 14 x 14 x 2
25	P0452Z009	L-WRENCH TORX T20
26	PFH35M	FLAT HD TORX SCR T20 M6-1 X 15
27	P0609027	BEARING SUPPORT
28	P62042RZ	BALL BEARING 62042RZ
29	PW01M	FLAT WASHER 8MM
30	P0609030	CUTTERHEAD SCREW
31	PN02M	HEX NUT M10-1.5
32	P0609032	BEARING COVER
33	PSB02M	CAP SCREW M6-1 X 20
34	PB156	HEX BOLT M10-1.5 X 150
35	PSS71M	SET SCREW M10-1.5 X 60
36	P0609036	BASE
37	PSS04M	SET SCREW M6-1 X 12
38	PW04M	FLAT WASHER 10MM
39	P0609039	LOCK HANDLE
40	PSS03M	SET SCREW M6-1 X 8
41	P0609041	ECCENTRIC BUSHING
42	P0609042	SHAFT
42-1	P0609042-1	LEFT TORSION SPRING
42-2	P0609042-2	RIGHT TORSION SPRING
43	P0609043	STOP BLOCK
44	PR21M	INT RETAINING RING 35MM

REF	PART #	DESCRIPTION
45	P0609045	SHAFT
46	PLW06M	LOCK WASHER 10MM
47	PB32M	HEX BOLT M10-1.5 X 25
48	P0609048	BUSHING
49	P0609049	WORM GEAR
50	PK12M	KEY 5 X 5 X 30
51	P0609051	GEAR
52	P0609052	WORM
53	PK37M	KEY 4 X 4 X 16
54	P0609054	SLIDE STOP BLOCK
55	P0609055	SLIDE STOP BLOCK
55-1	PSS16M	SET SCREW M8-1.25 X 10
56	P0609056	SPECIAL FLAT SCREW
57	P0609057	POINTER
58	PW02M	FLAT WASHER 5MM
59	PS09M	PHLP HD SCR M5-.8 X 10
60	PB73M	HEX BOLT M10-1.5 X 50
61	P0609061	CLAMP BLOCK
62	PLW06M	LOCK WASHER 10MM
63	PW04M	FLAT WASHER 10MM
64	P0609064	CLAMPING BLOCK
65	P0609065	CLAMP PLATE
66	PHTEK4M	TAP SCREW M4 X 8
67	P0609067	STOP BUTTON
68	P0609068	START BUTTON
69	P0609069	SWITCH BOX
70	PFS14M	FLANGE SCREW M8-1.25 X 16
71	P0609071	SWITCH BOX BRACKET
72	PB32M	HEX BOLT M10-1.5 X 25
73	PLW06M	LOCK WASHER 10MM
74	PW04M	FLAT WASHER 10MM
75	P0609075	BUTTON PLATE
76	P0609076	BALL STRAIN RELIEF
77	PAW10M	HEX WRENCH 10MM
78	PAW08M	HEX WRENCH 8MM
79	PAW03M	HEX WRENCH 3MM
80	PWR1719	WRENCH 17 X 19
81	PWR1214	COMBO WRENCH 12/14MM
82	PWR1012	COMBO WRENCH 10/12MM
84	P0609084	BUSHING
85	P6202	BALL BEARING 6202ZZ
86	PB06M	HEX BOLT M8-1.25 X 12
87	PW03M	FLAT WASHER 6MM
88	PB02M	HEX BOLT M6-1 X 12



# Tables Breakdown

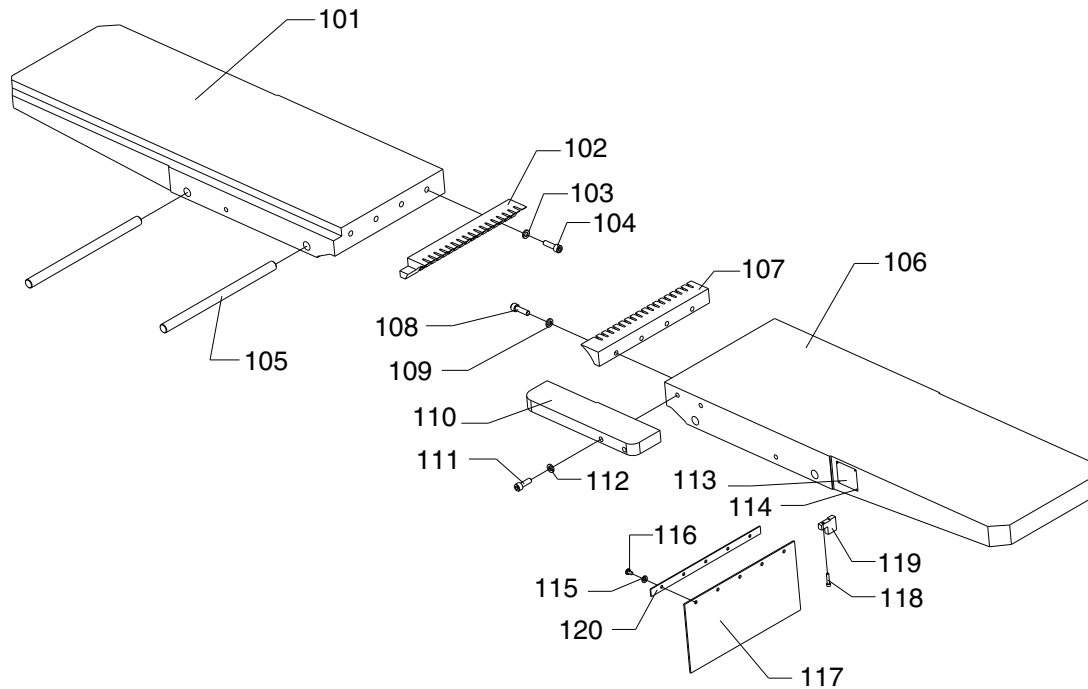

REF	PART #	DESCRIPTION
101	P0609101	TABLE (LEFT)
102	P0609102	TABLE LIP (LEFT)
103	PLW06M	LOCK WASHER 10MM
104	PSB84M	CAP SCREW M10-1.5 X 35
105	P0609105	SHAFT
106	P0609106	TABLE (RIGHT)
107	P0609107	TABLE LIP (RIGHT)
108	PSB84M	CAP SCREW M10-1.5 X 35
109	PLW06M	LOCK WASHER 10MM
110	P0609110	RABBETING ARM

REF	PART #	DESCRIPTION
111	PSB72M	CAP SCREW M10-1.5 X 30
112	PLW06M	LOCK WASHER 10MM
113	P0609113	DEPTH SCALE
114	P0609114	RIVET 2 X 4
115	PW03M	FLAT WASHER 6MM
116	PSB04M	CAP SCREW M6-1 X 10
117	P0609117	DUST DEFLECTOR
118	PSB38M	CAP SCREW M5-.8 X 25
119	P0609119	STOP BLOCK
120	P0609120	BAR



# Fence Breakdown

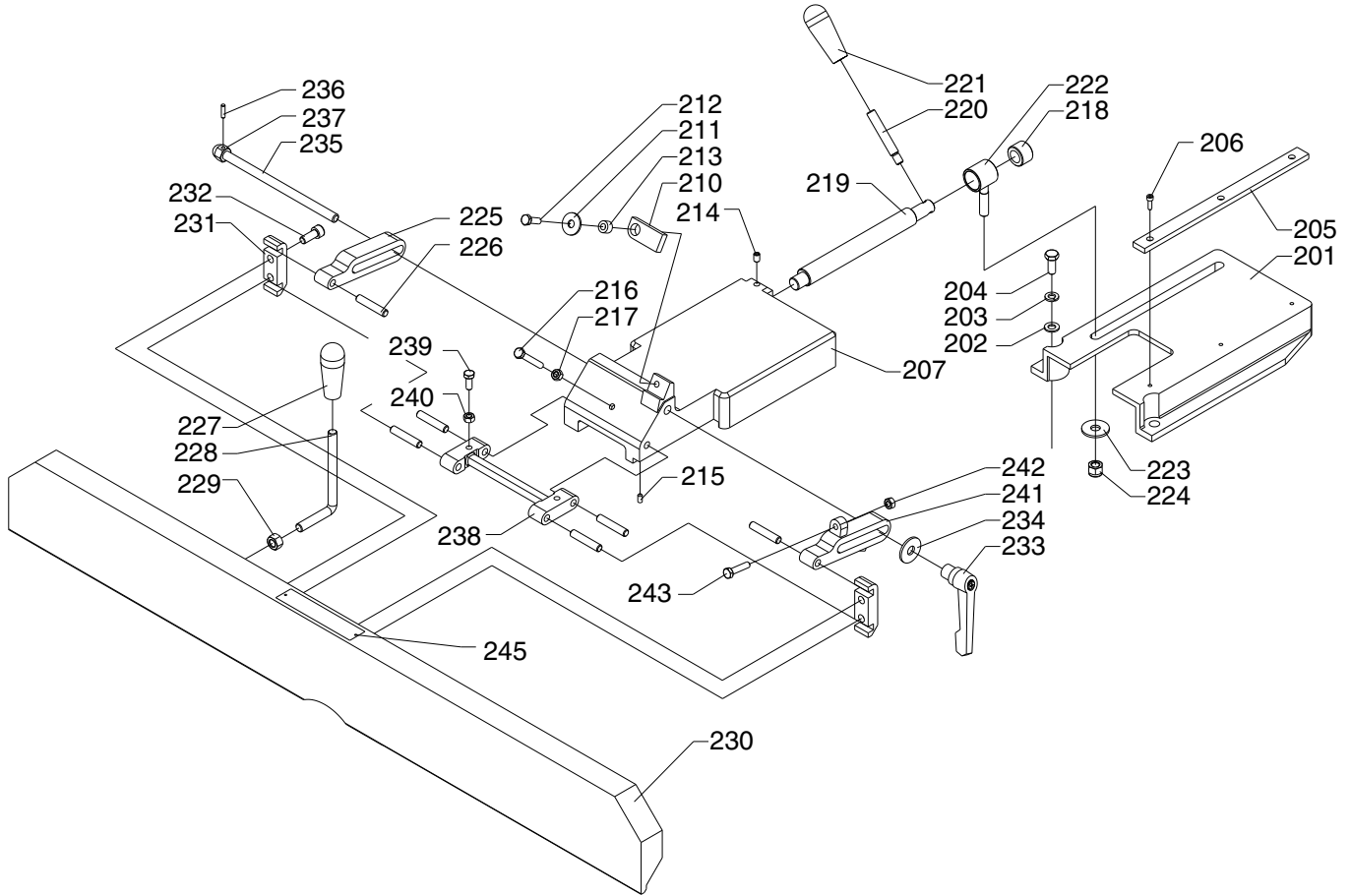

REF	PART #	DESCRIPTION
201	P0609201	FENCE BRACKET
202	PW06M	FLAT WASHER 12MM
203	PLW05M	LOCK WASHER 12MM
204	PSB77M	CAP SCREW M12-1.75 X 30
205	P0609205	SLIDING RAIL
206	PSB20M	CAP SCREW M5-.8 X 14
207	P0609207	SLIDING BRACKET
210	P0609210	BLOCK
211	PW01M	FLAT WASHER 8MM
212	PB07M	HEX BOLT M8-1.25 X 25
213	P0609213	COLLAR
214	PSS14M	SET SCREW M8-1.25 X 12
215	PSS04M	SET SCREW M6-1 X 12
216	PB30M	HEX BOLT M8-1.25 X 55
217	PN03M	HEX NUT M8-1.25
218	P0609218	COLLAR
219	P0609219	ECCENTRIC SHAFT
220	P0609220	HANDLE ROD
221	P0609221	HANDLE
222	P0609222	SLIDING BUSHING ASSY
223	PW06M	FLAT WASHER 12MM

REF	PART #	DESCRIPTION
224	P0609224	SPECIAL HEX NUT M12
225	P0609225	LEFT BRACKET
226	P0609226	PIN
227	P0609227	HANDLE
228	P0609228	HANDLE ROD
229	PN09M	HEX NUT M12-1.75
230	P0609230	FENCE
231	P0609231	CLAMP
232	PSB64M	CAP SCREW M10-1.5 X 25
233	P0609233	LOCK LEVER ASSY
234	P0609234	SPECIAL FLAT WASHER
235	P0609235	DOUBLE END THREADED ROD
236	PRP03M	ROLL PIN 5 X 20
237	P0609237	SPECIAL NUT M12
238	P0609238	SUPPORT BRACKET
239	PB09M	HEX BOLT M8-1.25 x 20
240	PN03M	HEX NUT M8-1.25
241	P0609241	RIGHT BRACKET
242	PN03M	HEX NUT M8-1.25
243	PB20M	HEX BOLT M8-1.25 X 35
245	P0609245	RIVET 2 X 5



# Stand Breakdown

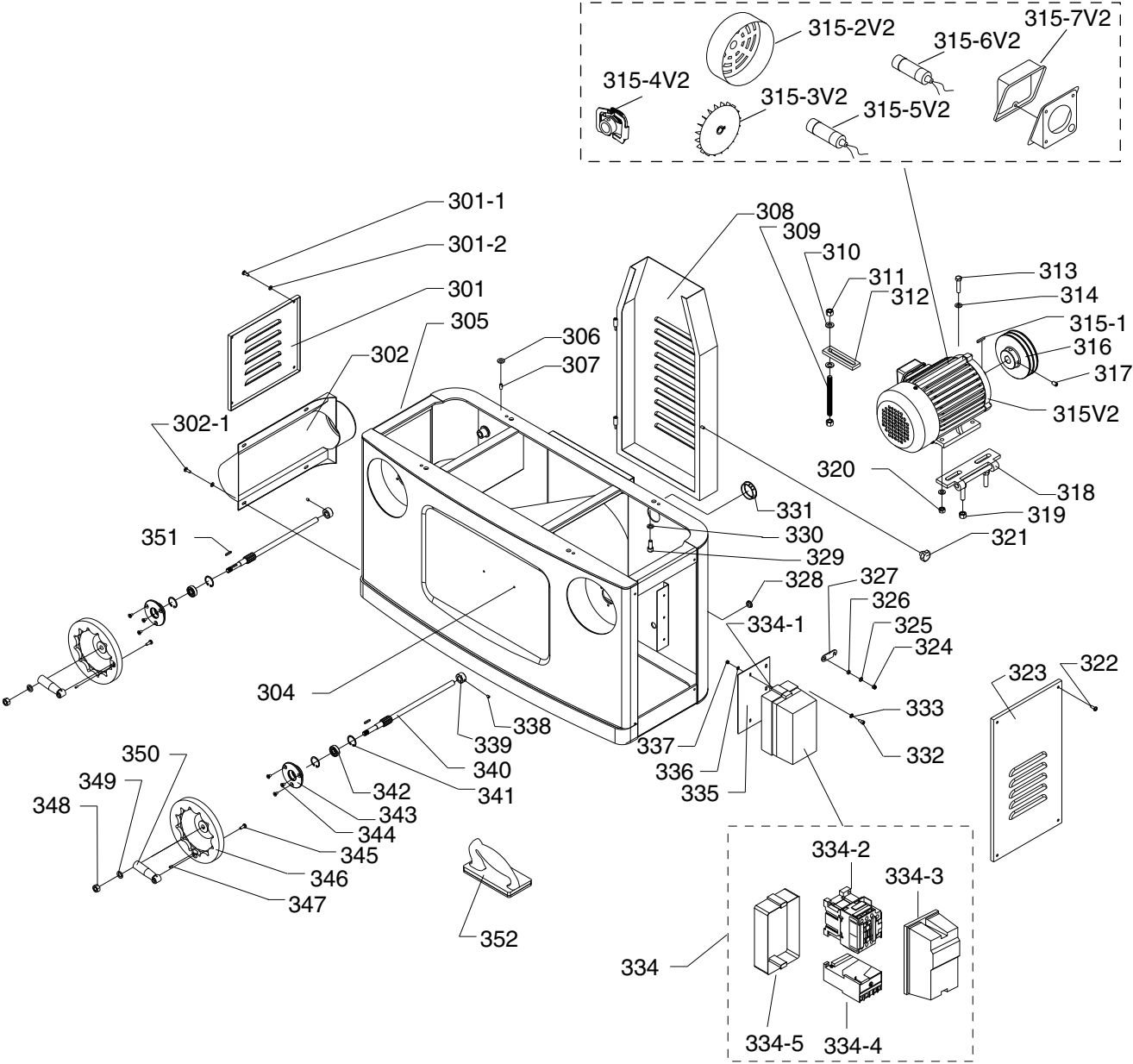

# Stand Parts List

REF	PART #	DESCRIPTION
301	P0609301	LEFT ACCESS DOOR
301-1	PSBS18M	BUTTON HD CAP SCR M6-1 X 18
301-2	PW03M	FLAT WASHER 6MM
302	P0609302	DUST HOOD
302-1	PSBS11M	BUTTON HD CAP SCR M6-1 X 10
304	PHTEK4M	TAP SCREW M4 X 8
305	P0609305	CABINET
306	P0609306	RUBBER WASHER 8MM
307	PSS80M	SET SCREW M8-1.25 X 15
308	P0609308	PULLEY COVER
309	P0609309	TENSION ROD
310	PW06M	FLAT WASHER 12MM
311	PN09M	HEX NUT M12-1.75
312	P0609312	TENSION PLATE
313	PB116M	HEX BOLT M10-1.5 X 45
314	PW04M	FLAT WASHER 10MM
315V2	P0609X315V2	MOTOR 3HP 220V V2.05.08
315-1V2	PK33M	KEY 5 X 5 X 45
315-2V2	P0609X315-2V2	FAN COVER V2.05.08
315-3V2	P0609X315-3V2	MOTOR FAN V2.05.08
315-4V2	P0609X315-4V2	CENTRIFUGAL SWITCH V2.05.08
315-5V2	P0609X315-5V2	S CAPACITOR 250M 250V 1-3/4 X 3-1/2
315-6V2	P0609X315-6V2	R CAPACITOR 40M 450V 1-3/8 X 2-3/8
315-7V2	P0609315-7V2	JUNCTION BOX V2.05.08
316	P0609316	MOTOR PULLEY
317	PSS75M	SET SCREW M10-1.5 X 16
318	P0609318	MOTOR BRACKET
319	PN09M	HEX NUT M12-1.75
320	PN02M	HEX NUT M10-1.5
321	P0609321	PULLEY COVER LOCK KNOB
322	PSBS18M	BUTTON HD CAP SCR M6-1 X 18
323	P0609323	RIGHT ACCESS DOOR
324	P0609324	SPECIAL HEX NUT M6

REF	PART #	DESCRIPTION
325	PW03M	FLAT WASHER 6MM
326	P0609326	ADAPTER
327	P0609327	LATCH
328	P0609328	SMALL STRAIN RELIEF
329	PSB64M	CAP SCREW M10-1.5 X 25
330	PLW06M	LOCK WASHER 10MM
331	P0609331	BIG STRAIN RELIEF
332	PSB04M	CAP SCREW M6-1 X 10
333	PW03M	FLAT WASHER 6MM
334	P0609334	MAGNETIC SWITCH
334-1	PS06M	PHLP HD SCR M5-.8 x 20
334-2	P0609334-2	CONTACTOR
334-3	P0609334-3	MAG SWITCH FRONT COVER
334-4	P0609334-4	THERMAL OVERLOAD RELAY
334-5	P0609334-5	MAG SWITCH BACK COVER
335	P0609335	SWITCH PLATE
336	PW02M	FLAT WASHER 5MM
337	PN06M	HEX NUT M5-.8
338	PSS03M	SET SCREW M6-1 X 8
339	P0609339	COLLAR
340	P0609340	SPIRAL GEAR SHAFT
341	PR29M	INT RETAINING RING 32MM
342	P6201	BALL BEARING 6201ZZ
343	P0609343	BEARING SUPPORT
344	PFH04M	FLAT HD SCR M6-1 X 8
345	PFS14M	FLANGE SCREW M6-1 X 16
346	P0609346	HANDWHEEL
347	PRP78M	ROLL PIN 4 X 10
348	PN09M	HEX NUT M12-1.75
349	PW06M	FLAT WASHER 12MM
350	P0609350	FOLDING HANDLE
351	PK34M	KEY 5 X 5 X 20
352	P0609352	PUSH BLOCK



# Labels Breakdown

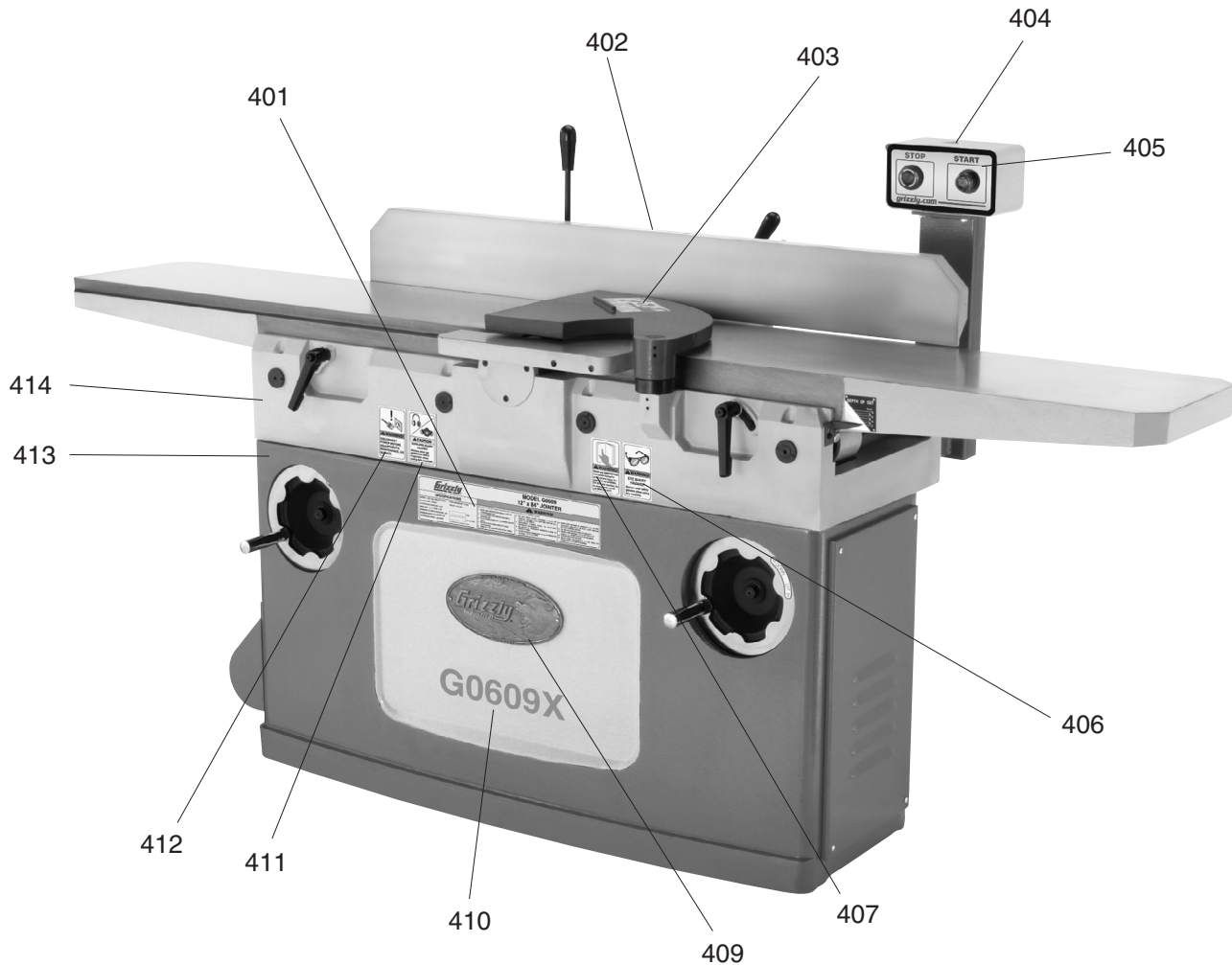

REF	PART #	DESCRIPTION
401	P0609X401	MACHINE ID LABEL
402	P0609402	CUTTERHEAD WARNING LABEL
403	P0609403	CUTTERHEAD GUARD LABEL
404	PLABEL-14	ELECTRICITY LABEL
405	P0609405	CONTROL PANEL FACE
406	PLABEL-11	SAFETY GLASSES LABEL
407	PLABEL-12A	READ MANUAL LABEL

REF	PART #	DESCRIPTION
408	PLABEL-15	EAR PROTECTION LABEL
409	G8589	GRIZZLY NAME PLATE-LARGE
410	P0609X410	MODEL NUMBER LABEL
411	P0609411	RESPIRATOR-HEARING LABEL
412	PLABEL-02B	UNPLUG POWER 220-440 LABEL
413	PPAINT-1	GRIZZLY GREEN PAINT
414	PPAINT-11	PUNITY TOUCH UP PAINT

## WARNING

Safety labels warn about machine hazards and ways to prevent injury. The owner of this machine **MUST** maintain the original location and readability of the labels on the machine. If any label is removed or becomes unreadable, **REPLACE** that label before using the machine again. Contact Grizzly at (800) 523-4777 or [www.grizzly.com](http://www.grizzly.com) to order new labels.

