

# READ THIS FIRST



Model G0459

**\*\*\*IMPORTANT UPDATE\*\*\***

For Machines Mfd. Since 02/26  
and Owner's Manual Revised 03/13

For questions or help with this product contact Tech Support at (570) 546-9663 or [techsupport@grizzly.com](mailto:techsupport@grizzly.com)

The following changes were recently made since the owner's manual was printed:

- Top cover and rear brace have changed.

Aside from this information, all other content in the owner's manual applies and **MUST** be read and understood for your own safety. **IMPORTANT: Keep this update with the owner's manual for future reference.**

For questions or help, contact our Tech Support at (570) 546-9663 or [techsupport@grizzly.com](mailto:techsupport@grizzly.com).

## Revised Parts

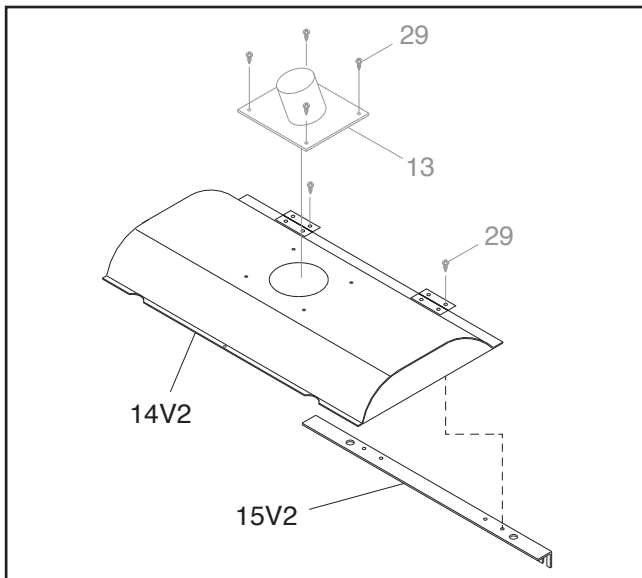

REF	PART #	DESCRIPTION
14V2	P0459014V2	TOP COVER V2.02.26
15V2	P0459015V2	REAR BRACE V2.02.26



COPYRIGHT © JANUARY, 2026 BY GRIZZLY INDUSTRIAL, INC.  
**WARNING: NO PORTION OF THIS MANUAL MAY BE REPRODUCED IN ANY SHAPE OR FORM WITHOUT THE WRITTEN APPROVAL OF GRIZZLY INDUSTRIAL, INC.**  
#JP23889 PRINTED IN TAIWAN

# READ THIS FIRST



**Model G0459**

**\*\*\*IMPORTANT UPDATE\*\*\***

**For Machines Mfd. Since 06/25  
and Owner's Manual Revised 07/14**

*For questions or help with this product contact Tech Support at (570) 546-9663 or [techsupport@grizzly.com](mailto:techsupport@grizzly.com)*

The following changes were recently made since the owner's manual was printed:

- Parts have changed.
- Lubrication steps have been added.

Aside from this information, all other content in the owner's manual applies and **MUST** be read and understood for your own safety. **IMPORTANT: Keep this update with the owner's manual for future reference.**

*For questions or help, contact our Tech Support at (570) 546-9663 or [techsupport@grizzly.com](mailto:techsupport@grizzly.com).*

## Revised Specifications

### Electrical

Power Cord Length..... 72"

### Items Needed

**Qty**

Phillips Head Screwdriver #2 ..... 1  
Oil Can ..... 1  
Shop Rags..... As Needed

## Revised Parts

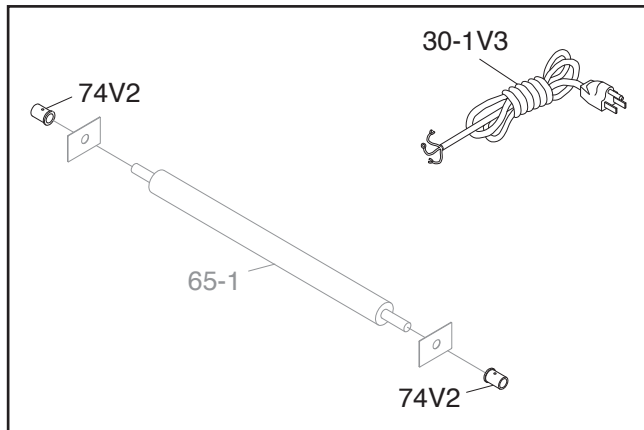

The conveyor roller bushings are located at each end of the front conveyor roller. These bushings require a small amount of machine oil daily to ensure smooth conveyor operation.

To lubricate the conveyor roller bushings, remove the front roller end guards and add 1–2 drops of machine oil to the lubrication hole in each bushing (see **Figure 1**). Wipe off excess oil to avoid sawdust buildup, then secure roller end guards.

REF	PART #	DESCRIPTION
30-1V3	P0459030-1V3	POWER CORD 14G 3W 72" V3.06.25
74V2	P0459074V2	BUSHING V2.06.25

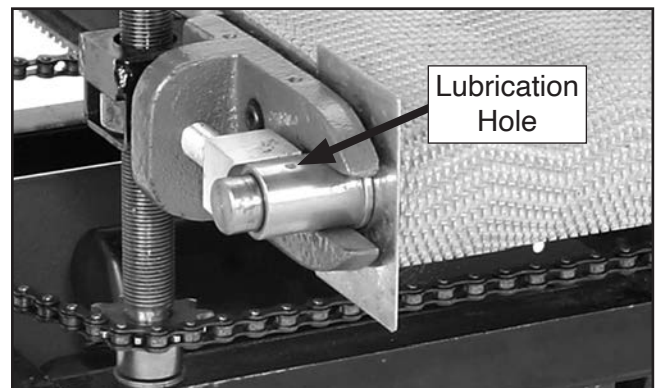

**Figure 1.** Location of conveyor roller bushing lubrication hole.

## Revised Lubrication

### Conveyor Roller Bushings

Lube Type..... SB1365 or ISO-68 Equivalent  
Lube Amount ..... 1–2 Drops  
Lube Frequency ..... Daily

COPYRIGHT © APRIL, 2025 BY GRIZZLY INDUSTRIAL, INC.  
**WARNING: NO PORTION OF THIS MANUAL MAY BE REPRODUCED IN ANY SHAPE OR FORM WITHOUT THE WRITTEN APPROVAL OF GRIZZLY INDUSTRIAL, INC.**  
#JP23565 PRINTED IN TAIWAN



# Frame Parts List

REF	PART #	DESCRIPTION
1	P0459001	FRAME
2	P0459002	HEX NUT 5/16-18
3	P0459003	FLAT WASHER 5/16
4	P0459004	SIDE PANEL
4	P0459004	SIDE PANEL
5	P0459005	HANDLE
5-1	P0459005-1	CAP SCREW 5/16-18 X 5/8
6	P0459006	SPROCKET V1
7-1	P0459007-1	SPROCKET SHAFT
7-2	P0459007-2	SPROCKET
8-1	P0459008-1	TABLE LEAD SCREW (1)
8-2	P0459008-2	TABLE LEAD SCREW (2)
8-3	P0459008-3	BUSHING
8-4	P0459008-4	WORM GEAR 25-TEETH
8-5	P0459008-5	KEY 5 X 5 X 10
8-6	P0459008-6	BUSHING
8-7	P0459008-7	FLAT WASHER 1/2
9	P0459009	ELEVATION CHAIN
10	P0459010	FRONT BRACE
10	P0459010	FRONT BRACE
11	P0459011	DEPTH SCALE
12	P0459012	RIGHT SUPPORT ARM
12-1	P0459012-1	PHLP HD SCR 6-32 X 1/4
12-2	P0459012-2	HEX NUT 6-32
13	P0459013	UNIVERSAL DUST PORT 2-1/2"
14	P0459014	TOP COVER
14	P0459014	TOP COVER
14-1	P0459014-1	HINGE
15	P0459015	REAR BRACE
15	P0459015	REAR BRACE
16V2	P0459016V2	REAR PANEL V2.03.09
16V2	P0459016V2	REAR PANEL V2.03.09
17	P0459017	SET SCREW 1/4-20 X 3/8
18	P0459018	MOTOR PULLEY
19	P0459019	KEY 5 X 5 X 30
20V2	P0459020V2	MOTOR 1.5HP 115V 1-PH V2.03.09
20-1	P0459020-1	MOTOR BRACKET
20-2	P0459020-2	S CAP 300M 125V 1-1/2 X 3-1/8
20-3	P0459020-3	CAPACITOR COVER
20-4V2	P0459020-4V2	JUNCTION BOX V2.03.09
20-5	P0459020-5	FAN COVER
20-6	P0459020-6	MOTOR FAN
20-7	P0459020-7	CENTRIFUGAL SWITCH
22	P0459022	HEX BOLT 5/16-18 X 3/4
24	P0459024	FLAT WASHER 5/16
28	P0459028	FLANGE SCREW M3-.6 X 16
29	P0459029	TAP SCREW #8 X 3/8
30-1V2	P0459030-1V2	POWER CORD V2.03.09
30-2V2	P0459030-2V2	MOTOR CORD V2.03.09
30-3V2	P0459030-3V2	VS POWER CORD V2.03.09
30-4V2	P0459030-4V2	DC MOTOR CORD V2.03.09
30-5	P0459030-5	CONTROL WIRE
31V2	P0459031V2	STRAIN RELIEF MGB16 V2.07.11
31-1	P0459031-1	STRAIN RELIEF 3/4"
32V3	P0459032V3	FRONT PANEL V3.01.11

REF	PART #	DESCRIPTION
32V3	P0459032V3	FRONT PANEL V3.01.11
33V2	P0459033V2	PUSH BUTTON SWITCH V2.03.09
34	P0459034	HEX NUT 5/16-18
40	P0459040	FLAT WASHER 5/16
44	P0459044	HEX NUT 1/4-20
45	P0459045	HEX BOLT 1/4-20 X 3/4
46V2	P0459046V2	PC BRD CONSOLE UNIT V2.03.09
54	P0459054	VARIABLE SPEED CTL KNOB
54-1	P0459054-1	POTENTIOMETER
55	P0459055	SPEED INDICATOR LABEL
56V2	P0459056V2	SWITCH BOX V2.03.09
56V2	P0459056V2	SWITCH BOX V2.03.09
57	P0459057	FLANGE SCREW 10-24 X 1/2
57-1	P0459057-1	HEX NUT #10-24
57-2	P0459057-2	PHLP HD SCR 10-24 X 3/8
59	P0459059	EXT TOOTH WASHER 5MM
99	P0459099	HEX WRENCH 3MM
100	P0459100	DUST SCOOP
100	P0459100	DUST SCOOP
101	P0459101	WORM GEAR SHAFT BRACKET
103	P0459103	SHAFT MOUNT
104	P0459104	WORM GEAR
107	P0459107	BUSHING
108	P0459108	HEX BOLT 1/4-20 X 1/2
109	P0459109	COLLAR
110	P0459110	WORM GEAR MOUNT WASHER
111	P0459111	WIRES
112V2	P0459112V2	GEAR COVER V2.07.11
112V2	P0459112V2	GEAR COVER V2.07.11
113	P0459113	CRANK HANDLE
113	P0459113	CRANK HANDLE
114	P0459114	HANDLE
115	P0459115	HEX NUT 3/8-16
117	P0459117	FLAT WASHER 5/16
118	P0459118	HEX BOLT 5/16-18 X 1
119	P0459119	SET SCREW 1/4-20 X 1/4
120	P0459120	OL RELAY YS 20A
121	P0459121	HEX NUT SIZE M11-1
122	P0459122	JUMPER
130	P0459130	PC BOARD COVER
132	P0459132	FRONT ELEVATION CHAIN GUARD
133	P0459133	REAR ELEVATION CHAIN GUARD
134	P0459134	PHLP HD SCR 10-24 X 3/8
135	P0459135	FLAT WASHER #10
136	P0459136	HEX NUT #10-24
137	P0459137	PADLOCK STORAGE HOOK
138	P0459138	SWITCH PADLOCK
209	P0459209	GRIZZLY NAMEPLATE-MINI
209-1	P0459209-1	TAP SCREW #5 X 3/8
211	P0459211	COVER LOCK KNOB
212V3	P0459212V3	MACHINE ID LABEL CSA V3.07.11
212V3	P0459212V3	MACHINE ID LABEL CSA V3.01.11
223	P0459P223	POLAR BEAR LOGO 2-1/2 X 9-1/2
224	P0459P224	POLAR BEAR WHITE TOUCH-UP PAINT
225	P0459P225	MODEL NUMBER LABEL



# Drum

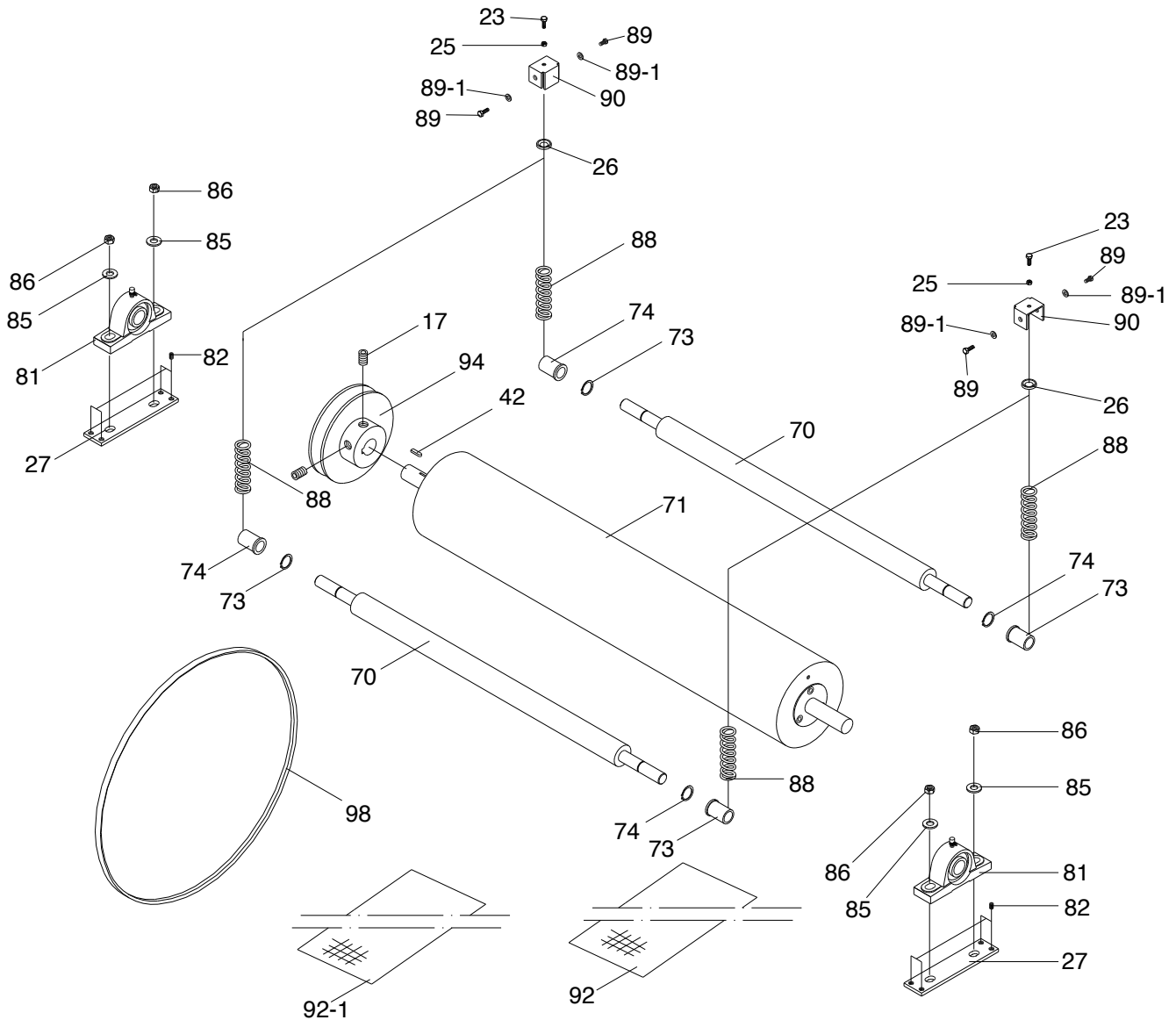

REF	PART #	DESCRIPTION
17	PSS03	SET SCREW 1/4-20 X 3/8
23	PB02	HEX BOLT 1/4-20 X 5/8
25	PN05	HEX NUT 1/4-20
26	P0459026	SPRING PLATE
27	P0459027	ADJUST PLATE
42	PK34M	KEY 5 X 5 X 20
70	P0459070	PRESSURE ROLLER
71	P0459071	SANDING DRUM
73	PR08M	EXT RETAINING RING 19MM
74	P1066062	BUSHING
81	PUCP205	PILLOW BLOCK BEARING UCP205

REF	PART #	DESCRIPTION
82	PSS51	SET SCREW 5/16-24 X 1/2
85	PW02	FLAT WASHER 3/8
86	PLN01	LOCK NUT 3/8-16
88	P0459088	COMP SPRING 24-20-8MM 63L
89	PB51	HEX BOLT 1/4-20 X 3/8
89-1	PW06	FLAT WASHER 1/4
90	P0459090	BRACKET
92	P0459092	HOOK & LOOP SANDBELT
92-1	P0459092-1	HOOK & LOOP DRUM COVER
94	P0459094	DRUM PULLEY
98	PVA36	V-BELT 4L360





# Conveyor Parts List

REF	PART #	DESCRIPTION
17	PSS03	SET SCREW 1/4-20 X 3/8
25	PN05	HEX NUT 1/4-20
35	PN03	HEX NUT 3/4-16
36	P0459036	TABLE FRAME
38V2	P0459038V2	CONVEYOR MOTOR BRACKET V2.03.09
39V4	P0459039V4	DC FEED MOTOR 105W V4.11.09
39V4-1	PS56M	PHLP HD SCR M4-.7 X 16
39V4-2	PLW02M	LOCK WASHER 4MM
39V4-3	P0459039V4-3	END CASE V4.11.09
39V4-4	P0459039V4-4	DRIVE GEAR V4.11.09
39V4-5	P6003ZZ	BALL BEARING 6003ZZ
39V4-6	P0459039V4-6	MAIN CASE V4.11.09
39V4-7	P6000ZZ	BALL BEARING 6000ZZ
39V4-8	PR06M	EXT RETAINING RING 16MM
39V4-9	P0459039V4-9	ARMATURE V4.11.09
39V4-10	P0459039V4-10	FEED MOTOR POWER CORD V4.11.09
39V4-11	P0459039V4-11	STATOR HOUSING V4.11.09
39V4-12	P0459039V4-12	MIDDLE CAP V4.11.09
39V4-13	P0459039V4-13	CARBON BRUSH ASSEMBLY V4.11.09
39V4-14	P0459039V4-14	PLASTIC LOCK CAP V4.11.09
39V4-15	P0459039V4-15	END CAP V4.11.09
39V4-16	PS19M	PHLP HD SCR M5-.8 X 6
50-1	P0459050-1	LEFT ROLLER END GUARD COVER
50-2	P0459050-2	RIGHT ROLLER END GUARD COVER
51V2	P0459051V2	LEFT ROLLER BRACKET V2.07.11
51-1V2	P0459051-1V2	RIGHT FRONT ROLLER BRACKET V2.07.11

REF	PART #	DESCRIPTION
51-2V4	P0459051-2V4	LEFT REAR ROLLER BRACKET V4.01.11
51-3V2	P0459051-3V2	RIGHT REAR ROLLER BRACKET V2.07.11
52	PFH12	FLAT HD SCR 1/4-20 X 1
57	PFS17	FLANGE SCREW 10-24 X 1/2
58	PCAP01	CAP SCREW 1/4-20 X 5/8
60	P0459060	ROLLER BRACKET BOLT
61	P0459061	BUSHING SUPPORT
63	P0459063	SET SCREW 1/4-20 X 3/16
64	P0459064	PLATE
65V3	P0459065V3	DRIVE ROLLER V3.09.09
65-1	P0459065-1	IDLER ROLLER
66	P0459066	TABLE
69	P0459069	CONVEYOR BELT 1220 X 312MM
74	P1066062	BUSHING
76	PW06	FLAT WASHER 1/4
77	P0459077	SCALE POINTER
78	PCAP01	CAP SCREW 1/4-20 X 5/8
79	PS06	PHLP HD SCR 10-24 X 3/8
80	PW03	FLAT WASHER #10
83	PCAP28M	CAP SCREW M6-1 X 15
102	PLN02	LOCK NUT 1/4-20
123	P0459123	COLLAR
124	PK23M	KEY 5 X 5 X 25
125	P6003-2RS	BALL BEARING 6003-2RS
126	PSS11	SET SCREW 1/4-20 X 1/4
127	PCAP06	CAP SCREW 1/4-20 X 1

## Label Placement

REF	PART #	DESCRIPTION
55	P0459055	SPEED INDICATOR LABEL
209	G9987	GRIZZLY NAMEPLATE-MINI
212V3	P0459212V3	MACHINE ID LABEL CSA V3.07.11
212V3	P0459P212V3	MACHINE ID LABEL CSA V3.07.11
213	P0459213	RESPIRATOR-GLASSES LABEL
214	PLABEL-22	HAND PINCH IN BELT LABEL
215	P0459215	KICKBACK HAZARD LABEL
216	P0459216	DISCONNECT POWER LABEL
217	PLABEL-14	ELECTRICITY LABEL
218	PLABEL-12B	READY MANUAL HZ LABEL
221	PPAINT-1	GRIZZLY GREEN TOUCH-UP PAINT
222	PPAINT-7	BLACK TOUCH-UP PAINT

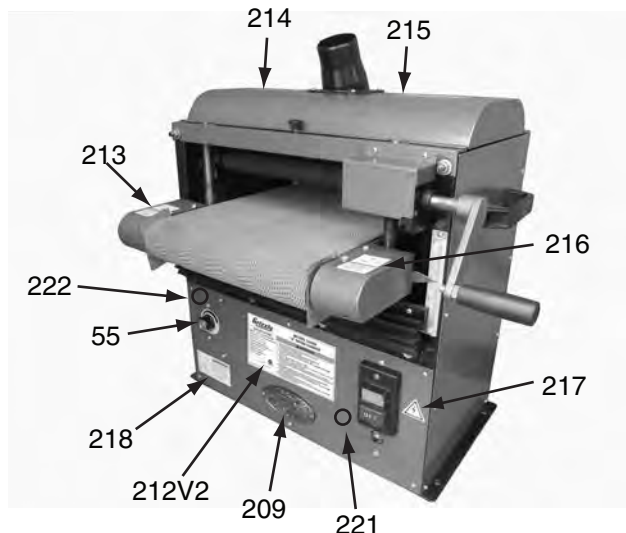

## WARNING

Safety labels warn about machine hazards and ways to prevent injury. The owner of this machine **MUST** maintain the original location and readability of the labels on the machine. If any label is removed or becomes unreadable, **REPLACE** that label before using the machine again. Contact Grizzly at (800) 523-4777 or [www.grizzly.com](http://www.grizzly.com) to order new labels.

