

Grizzly *Industrial, Inc.*®

MODEL G9983 **15" OPEN-END** **WIDE-BELT SANDER** **OWNER'S MANUAL** *(For models manufactured since 8/09)*



COPYRIGHT © OCTOBER, 2002 BY GRIZZLY INDUSTRIAL, INC., REVISED JUNE, 2013 (TS)
**WARNING: NO PORTION OF THIS MANUAL MAY BE REPRODUCED IN ANY SHAPE
OR FORM WITHOUT THE WRITTEN APPROVAL OF GRIZZLY INDUSTRIAL, INC.**
#TR4202 PRINTED IN TAIWAN



WARNING!

This manual provides critical safety instructions on the proper setup, operation, maintenance, and service of this machine/tool. Save this document, refer to it often, and use it to instruct other operators.

Failure to read, understand and follow the instructions in this manual may result in fire or serious personal injury—including amputation, electrocution, or death.

The owner of this machine/tool is solely responsible for its safe use. This responsibility includes but is not limited to proper installation in a safe environment, personnel training and usage authorization, proper inspection and maintenance, manual availability and comprehension, application of safety devices, cutting/sanding/grinding tool integrity, and the usage of personal protective equipment.

The manufacturer will not be held liable for injury or property damage from negligence, improper training, machine modifications or misuse.



WARNING!

Some dust created by power sanding, sawing, grinding, drilling, and other construction activities contains chemicals known to the State of California to cause cancer, birth defects or other reproductive harm. Some examples of these chemicals are:

- **Lead from lead-based paints.**
- **Crystalline silica from bricks, cement and other masonry products.**
- **Arsenic and chromium from chemically-treated lumber.**

Your risk from these exposures varies, depending on how often you do this type of work. To reduce your exposure to these chemicals: Work in a well ventilated area, and work with approved safety equipment, such as those dust masks that are specially designed to filter out microscopic particles.

Table of Contents

INTRODUCTION	2	SECTION 4: OPERATIONS	22
Contact Info.....	2	Operation Overview	22
Manual Accuracy	2	Choosing Sandpaper	23
Machine Data Sheet	3	Conveyor Belt Height.....	23
Basic Controls & Features	5	Feed Belt Speed	24
External Features.....	5	Load Meter.....	24
Control Panel	5	Platen Depth	25
Left Access Door	6		
Right Access Door	6		
SECTION 1: SAFETY	7	SECTION 5: ACCESSORIES	26
Safety Instructions for Machinery	7	SECTION 6: MAINTENANCE	27
Additional Safety for Wide-Belt Sanders	9	Schedule	27
		Cleaning.....	27
		Lubrication	27
		Emptying Regulator Filters	27
SECTION 2: POWER SUPPLY	10	SECTION 7: SERVICE	28
Availability	10	Troubleshooting	28
Full-Load Current Rating	10	Oscillation Timing.....	30
Circuit Information.....	10	Oscillation Speed	30
Circuit Requirements for 220V.....	10	Oscillation Return.....	31
Connection Type.....	11	Limit Switches	32
Grounding Instructions.....	11	Pressure Roller Depth	32
Extension Cords.....	11	Pressure Roller Tension	33
		Feed Belt Tension.....	34
		Feed Belt Tracking.....	34
		V-Belt Tension	35
		Replacing V-Belts	35
		Platen Graphite	37
		Air System.....	37
		Replacing Brakes.....	38
		Air System.....	39
SECTION 3: SETUP	12	SECTION 8: WIRING	40
Unpacking	12	Wiring Safety Instructions	40
Needed for Setup.....	12	Electrical Panel Wiring Diagram	41
Inventory	12	Control Panel Wiring.....	42
Cleanup.....	13	Motor & Limit Switch Wiring.....	43
Site Considerations.....	14		
Mounting	15	SECTION 9: PARTS	44
Bolting to Concrete Floors	15	WARRANTY & RETURNS	57
Assembly	16		
Installing Handwheel Handle	16		
Installing Platen.....	16		
Connecting Air Hose	17		
Installing Sanding Belt	18		
Sanding Belt Tension.....	18		
Pressure Rollers	19		
Dust Collection.....	19		
Power Connection.....	20		
Connecting to Power Source	20		
Disconnecting from Power Source	20		
Test Run	20		
Recommend Adjustments.....	21		

INTRODUCTION

Contact Info

We stand behind our machines. If you have any questions or need help, use the information below to contact us. Before contacting, please get the serial number and manufacture date of your machine. This will help us help you faster.

Grizzly Technical Support
1203 Lycoming Mall Circle
Muncy, PA 17756
Phone: (570) 546-9663
Email: techsupport@grizzly.com

We want your feedback on this manual. What did you like about it? Where could it be improved? Please take a few minutes to give us feedback.

Grizzly Documentation Manager
P.O. Box 2069
Bellingham, WA 98227-2069
Email: manuals@grizzly.com

Manual Accuracy

We are proud to provide a high-quality owner's manual with your new machine!

We made every effort to be exact with the instructions, specifications, drawings, and photographs contained inside. Sometimes we make mistakes, but our policy of continuous improvement also means that **sometimes the machine you receive will be slightly different than what is shown in the manual.**

If you find this to be the case, and the difference between the manual and machine leaves you confused about a procedure, check our website for an updated version. We post current manuals and manual updates for free on our website at **www.grizzly.com**.

Alternatively, you can call our Technical Support for help. Before calling, please write down the **Manufacture Date** and **Serial Number** stamped into the machine ID label (see below). This information helps us determine if updated documentation is available for your machine.

		MODEL GXXXX MACHINE NAME	
SPECIFICATIONS		▲ WARNING!	
Motor:	To reduce risk of serious injury when using this machine:		
Specification:	Read manual before operation.		
Specification:	Wear safety glasses and respirator.		
Specification:	Adjust safety devices correctly adjusted/setup and		
Specification:	power is connected to grounded circuit before starting.		
Weight:	4. Make sure the motor has stopped and disconnect		
	power before adjustments, maintenance, or service.		
	5. DO NOT expose to rain or dampness.		
	6. DO NOT modify this machine in any way.		
	7.		
	8.		
	9. Do not use while under the influence of drugs or alcohol.		
	10. Maintain machine carefully to prevent accidents.		
Manufactured for Grizzly in Taiwan			

Manufacture Date

Serial Number





MACHINE DATA SHEET

Customer Service #: (570) 546-9663 · To Order Call: (800) 523-4777 · Fax #: (800) 438-5901

MODEL G9983 15" WIDE-BELT SANDER (OPEN END)

Product Dimensions:

Weight..... 815 lbs.
 Width (side-to-side) x Depth (front-to-back) x Height..... 32-1/2 x 35 x 61-3/4 in.
 Footprint (Length x Width)..... 29 x 23-1/2 in.

Shipping Dimensions:

Type..... Wood Slat Crate
 Content..... Machine
 Weight..... 908 lbs.
 Length x Width x Height..... 36 x 37 x 69 in.
 Must Ship Upright..... Yes

Electrical:

Power Requirement..... 220V, Single-Phase, 60 Hz
 Prewired Voltage..... 220V
 Full-Load Current Rating..... 31.8A
 Minimum Circuit Size..... 40A
 Connection Type..... Permanent (Hardwire)
 Switch Type..... Control Panel w/Magnetic Switch Protection

Motors:

Main

Type..... TEFC Capacitor-Start Induction
 Horsepower..... 5 HP
 Phase..... Single-Phase
 Amps..... 30A
 Speed..... 1725 RPM
 Power Transfer Twin V-Belt Drive
 Bearings..... Sealed & Permanently Lubricated

Feed

Type..... TEFC Capacitor-Start Induction
 Horsepower..... 1/4 HP
 Phase..... Single-Phase
 Amps..... 1.8A
 Speed..... 1725 RPM
 Power Transfer Gear Drive
 Bearings..... Sealed & Permanently Lubricated



Main Specifications:

Operation Information

No Of Sanding Heads.....	1
Maximum Board Width.....	15 in.
Minimum Board Width.....	2 in.
Maximum Board Thickness.....	5-1/2 in.
Minimum Board Thickness.....	1/8 in.
Minimum Board Length.....	12 in.
Sandpaper Speed.....	2050 FPM
Sanding Belt Oscillations.....	5/8 – 3/4 in.
Conveyor Feed Rate.....	13.1, 16.4 FPM
Sandpaper Length.....	48 in.
Sandpaper Width.....	16 in.

Drum Information

Infeed Sanding Drum Type.....	Spiral Grooved Rubber
Infeed Sanding Drum Size.....	4 in.
Outfeed Sanding Drum Type.....	Steel
Outfeed Sanding Drum Size.....	3 in.

Platen Information

Platen Type.....	Adjustable
Platen Length.....	16-1/2 in.
Platen Width.....	1-3/4 in.
Platen Travel.....	0 – 2 mm

Construction

Conveyor Belt.....	Rubber
Body.....	Steel
Paint.....	Powder Coated

Other Related Information

Floor To Table Height.....	34-1/2 in.
Belt Tracking.....	Pneumatic
Sanding Belt Tension.....	Pneumatic
No Of Pressure Rollers.....	2
Pressure Roller Type.....	Rubber
Pressure Roller Size.....	1-5/8 in.
Conveyor Belt Length.....	64-1/2 in.
Conveyor Belt Width.....	15 in.
Belt Roller Size.....	4 in.
No Of Dust Ports.....	1
Dust Port Size.....	5 in.
Air Requirement.....	75 PSI

Other Specifications:

Country Of Origin	Taiwan
Warranty	1 Year
Approximate Assembly & Setup Time	30 Minutes
Serial Number Location	ID Label on Center of the Stand
ISO 9001 Factory	No
CSA Certified	No



Basic Controls & Features

To help you understand the set up and operation instructions, we recommend that you become familiar with the basic features of your new sander.

External Features

Please match up the list below with the letters in **Figure 1** to identify the external sander components.

- A. Control Panel
- B. Table Extension
- C. Conveyor Height Handwheel
- D. Conveyor Height Gauge
- E. Dust Port
- F. Load Meter
- G. Emergency Stop Bar
- H. Pressure Regulator

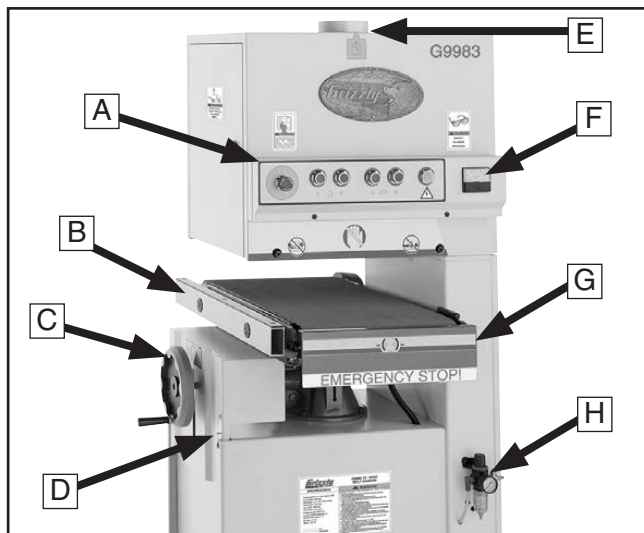

Figure 1. These are the basic external components of the sander.

Control Panel

The control panel houses the main power switch, the feed belt ON/OFF buttons and the sanding belt ON/OFF buttons. Please refer to **Figure 2** to identify these controls.

- A. Main Power ON / Emergency STOP switch.
- B. Sanding Belt OFF button.
- C. Sanding Belt ON button.
- D. Feed Belt OFF button.
- E. Feed Belt ON button.
- F. Power Indicator Light

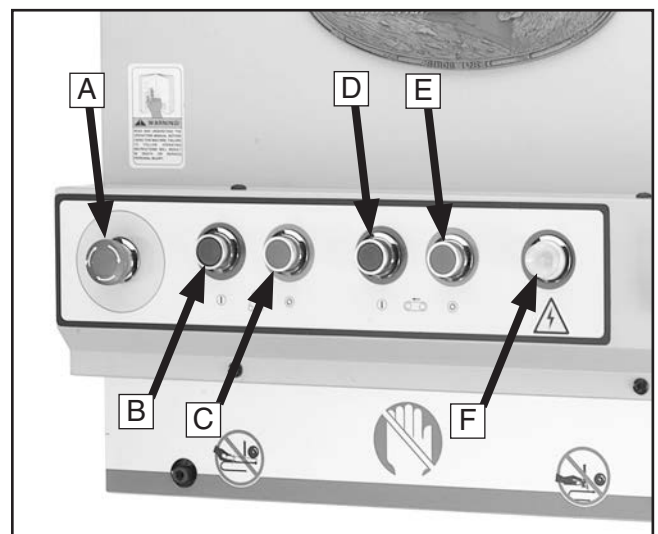

Figure 2. These are the main power controls.



Left Access Door

There are access doors located on each side of the sander. Throughout the manual, we refer to these doors as the “left-hand access door” and the “right-hand access door.” These terms are referenced as if you are facing the front of the machine.

Figure 3 shows the layout behind the left-hand access door.

- A. Limit Switch
- B. Sanding Belt Tension Switch
- C. Platen Adjustment Knob

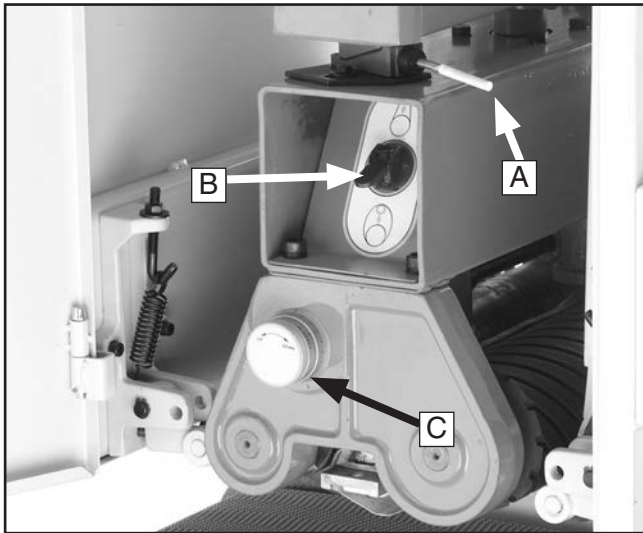

Figure 3. These items are behind the left-hand access door.

Right Access Door

Figure 4 shows the layout behind the right-hand access door.

- A. Oscillating Roller
- B. Oscillation Air Filter
- C. Limit Switch
- D. Oscillation Return Valve
- E. Oscillation Speed Valve
- F. Oscillation Timing Knob

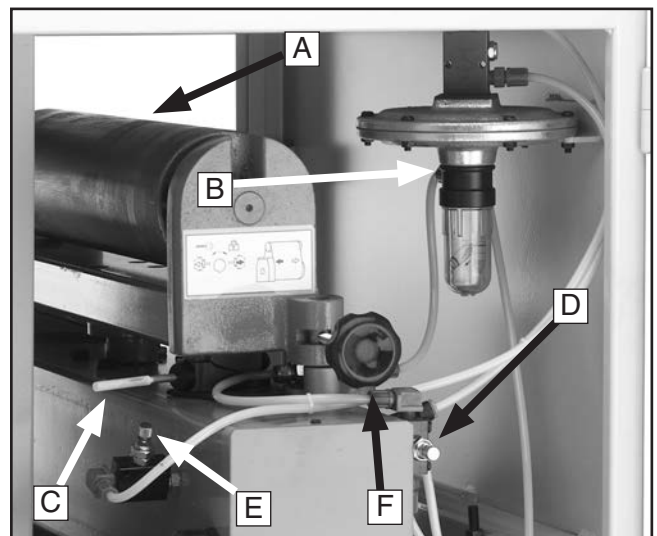

Figure 4. These items are behind the right-hand access door.



SECTION 1: SAFETY

For Your Own Safety, Read Instruction Manual Before Operating This Machine

The purpose of safety symbols is to attract your attention to possible hazardous conditions. This manual uses a series of symbols and signal words intended to convey the level of importance of the safety messages. The progression of symbols is described below. Remember that safety messages by themselves do not eliminate danger and are not a substitute for proper accident prevention measures. Always use common sense and good judgment.



Indicates an imminently hazardous situation which, if not avoided, **WILL** result in death or serious injury.



Indicates a potentially hazardous situation which, if not avoided, **COULD** result in death or serious injury.



Indicates a potentially hazardous situation which, if not avoided, **MAY** result in minor or moderate injury. It may also be used to alert against unsafe practices.

NOTICE

This symbol is used to alert the user to useful information about proper operation of the machine.

Safety Instructions for Machinery

WARNING

OWNER'S MANUAL. Read and understand this owner's manual **BEFORE** using machine.

TRAINED OPERATORS ONLY. Untrained operators have a higher risk of being hurt or killed. Only allow trained/supervised people to use this machine. When machine is not being used, disconnect power, remove switch keys, or lock-out machine to prevent unauthorized use—especially around children. Make workshop kid proof!

DANGEROUS ENVIRONMENTS. Do not use machinery in areas that are wet, cluttered, or have poor lighting. Operating machinery in these areas greatly increases the risk of accidents and injury.

MENTAL ALERTNESS REQUIRED. Full mental alertness is required for safe operation of machinery. Never operate under the influence of drugs or alcohol, when tired, or when distracted.

ELECTRICAL EQUIPMENT INJURY RISKS. You can be shocked, burned, or killed by touching live electrical components or improperly grounded machinery. To reduce this risk, only allow qualified service personnel to do electrical installation or repair work, and always disconnect power before accessing or exposing electrical equipment.

DISCONNECT POWER FIRST. Always disconnect machine from power supply **BEFORE** making adjustments, changing tooling, or servicing machine. This prevents an injury risk from unintended startup or contact with live electrical components.

EYE PROTECTION. Always wear ANSI-approved safety glasses or a face shield when operating or observing machinery to reduce the risk of eye injury or blindness from flying particles. Everyday eyeglasses are **NOT** approved safety glasses.



WARNING

WEARING PROPER APPAREL. Do not wear clothing, apparel or jewelry that can become entangled in moving parts. Always tie back or cover long hair. Wear non-slip footwear to avoid accidental slips, which could cause loss of workpiece control.

HAZARDOUS DUST. Dust created while using machinery may cause cancer, birth defects, or long-term respiratory damage. Be aware of dust hazards associated with each workpiece material, and always wear a NIOSH-approved respirator to reduce your risk.

HEARING PROTECTION. Always wear hearing protection when operating or observing loud machinery. Extended exposure to this noise without hearing protection can cause permanent hearing loss.

REMOVE ADJUSTING TOOLS. Tools left on machinery can become dangerous projectiles upon startup. Never leave chuck keys, wrenches, or any other tools on machine. Always verify removal before starting!

USE CORRECT TOOL FOR THE JOB. Only use this tool for its intended purpose—do not force it or an attachment to do a job for which it was not designed. Never make unapproved modifications—modifying tool or using it differently than intended may result in malfunction or mechanical failure that can lead to personal injury or death!

AWKWARD POSITIONS. Keep proper footing and balance at all times when operating machine. Do not overreach! Avoid awkward hand positions that make workpiece control difficult or increase the risk of accidental injury.

CHILDREN & BYSTANDERS. Keep children and bystanders at a safe distance from the work area. Stop using machine if they become a distraction.

GUARDS & COVERS. Guards and covers reduce accidental contact with moving parts or flying debris. Make sure they are properly installed, undamaged, and working correctly.

FORCING MACHINERY. Do not force machine. It will do the job safer and better at the rate for which it was designed.

NEVER STAND ON MACHINE. Serious injury may occur if machine is tipped or if the cutting tool is unintentionally contacted.

STABLE MACHINE. Unexpected movement during operation greatly increases risk of injury or loss of control. Before starting, verify machine is stable and mobile base (if used) is locked.

USE RECOMMENDED ACCESSORIES. Consult this owner's manual or the manufacturer for recommended accessories. Using improper accessories will increase the risk of serious injury.

UNATTENDED OPERATION. To reduce the risk of accidental injury, turn machine **OFF** and ensure all moving parts completely stop before walking away. Never leave machine running while unattended.

MAINTAIN WITH CARE. Follow all maintenance instructions and lubrication schedules to keep machine in good working condition. A machine that is improperly maintained could malfunction, leading to serious personal injury or death.

CHECK DAMAGED PARTS. Regularly inspect machine for any condition that may affect safe operation. Immediately repair or replace damaged or mis-adjusted parts before operating machine.

MAINTAIN POWER CORDS. When disconnecting cord-connected machines from power, grab and pull the plug—NOT the cord. Pulling the cord may damage the wires inside. Do not handle cord/plug with wet hands. Avoid cord damage by keeping it away from heated surfaces, high traffic areas, harsh chemicals, and wet/damp locations.

EXPERIENCING DIFFICULTIES. If at any time you experience difficulties performing the intended operation, stop using the machine! Contact our Technical Support at (570) 546-9663.



WARNING

Additional Safety for Wide-Belt Sanders

KICKBACK. Kickback is typically defined as the high-speed expulsion of stock from the machine, which can cause serious personal injury to the operator or bystanders. Until you have a clear understanding how kickback can occur when using this machine, DO NOT operate this sander!

WORKPIECE FEED RATE. Forcing or jamming the workpiece into the sander or against the sanding belt can cause it to kickback into the operator. Always use the correct depth of cut, then firmly hold the workpiece and ease it into the sander at the same feed rate as the conveyor.

AVOIDING ENTANGLEMENT. Becoming entangled in the moving parts of this machine can cause pinching and crushing injuries. To avoid these hazards, DO NOT wear loose clothing, gloves, or jewelry, and tie back long hair. Keep all guards in place and cabinet doors closed and secure.

HAND PLACEMENT. The sanding belt can remove a large amount of flesh in a few seconds. Always keep hands away from the sanding belt. Avoid pinching injuries by never putting your hand between the workpiece and the machine.

WORKPIECE QUANTITY. Never sand two or more workpieces side-by-side. Since workpieces are never exactly the same thickness, one of them may be thrown from the sander at a high rate of speed and could cause serious personal injury.

WORKPIECE INSPECTION. Nails, staples, knots, or other imperfections in the workpiece can be dislodged and thrown from the sander at a high rate of speed into the operator or bystanders. Never attempt to sand stock that has imperfections or embedded foreign objects.

BODY PLACEMENT. In case of kickback, avoid personal injury by always keeping your body to the side of the sanding path.

POWER DISCONNECT. Accidental start up or contact with live wiring could result in serious personal injury or death. Always disconnect the sander from power and air when changing the sanding belt, making adjustments, performing maintenance, or servicing the machine.

UNATTENDED MACHINE. This machine represents serious hazards to an untrained operator. Always turn the machine **OFF** and remove the conveyor belt disabling key before leaving the machine.

WARNING

Like all machinery there is potential danger when operating this machine. Accidents are frequently caused by lack of familiarity or failure to pay attention. Use this machine with respect and caution to decrease the risk of operator injury. If normal safety precautions are overlooked or ignored, serious personal injury may occur.

CAUTION

No list of safety guidelines can be complete. Every shop environment is different. Always consider safety first, as it applies to your individual working conditions. Use this and other machinery with caution and respect. Failure to do so could result in serious personal injury, damage to equipment, or poor work results.



SECTION 2: POWER SUPPLY

Availability

Before installing the machine, consider the availability and proximity of the required power supply circuit. If an existing circuit does not meet the requirements for this machine, a new circuit must be installed. To minimize the risk of electrocution, fire, or equipment damage, installation work and electrical wiring must be done by an electrician or qualified service personnel in accordance with all applicable codes and standards.

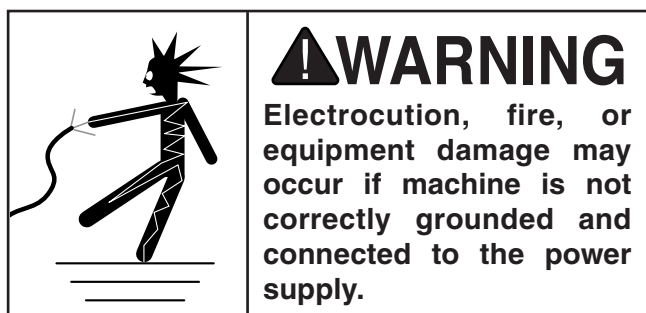

Full-Load Current Rating

The full-load current rating is the amperage a machine draws at 100% of the rated output power. On machines with multiple motors, this is the amperage drawn by the largest motor or sum of all motors and electrical devices that might operate at one time during normal operations.

Full-Load Current Rating at 220V .. 31.8 Amps

The full-load current is not the maximum amount of amps that the machine will draw. If the machine is overloaded, it will draw additional amps beyond the full-load rating.

If the machine is overloaded for a sufficient length of time, damage, overheating, or fire may result—especially if connected to an undersized circuit. To reduce the risk of these hazards, avoid overloading the machine during operation and make sure it is connected to a power supply circuit that meets the requirements in the following section.

Circuit Information

A power supply circuit includes all electrical equipment between the breaker box or fuse panel in the building and the machine. The power supply circuit used for this machine must be sized to safely handle the full-load current drawn from the machine for an extended period of time. (If this machine is connected to a circuit protected by fuses, use a time delay fuse marked D.)

! CAUTION
For your own safety and protection of property, consult an electrician if you are unsure about wiring practices or electrical codes in your area.

Note: *The circuit requirements listed in this manual apply to a dedicated circuit—where only one machine will be running at a time. If this machine will be connected to a shared circuit where multiple machines will be running at the same time, consult a qualified electrician to ensure that the circuit is properly sized for safe operation.*

Circuit Requirements for 220V

This machine is prewired to operate on a 220V power supply circuit that has a verified ground and meets the following requirements:

Nominal Voltage 220V/240V
Cycle 60 Hz
Phase Single-Phase
Power Supply Circuit 40 Amps



Connection Type

A permanently connected (hardwired) power supply is typically installed with wires running through mounted and secured conduit. A disconnecting means, such as a locking switch (see following **Figure**), must be provided to allow the machine to be disconnected (isolated) from the power supply when required. This installation must be performed by an electrician in accordance with all applicable electrical codes and ordinances.

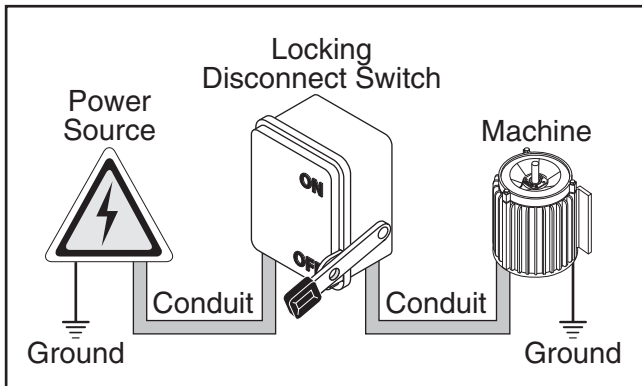

Figure 5. Typical setup of a permanently connected machine.

Grounding Instructions

In the event of a malfunction or breakdown, grounding provides a path of least resistance for electrical current to reduce the risk of electric shock. A permanently connected machine must be connected to a grounded metal permanent wiring system; or to a system having an equipment-grounding conductor. All grounds must be verified and rated for the electrical requirements of the machine. Improper grounding can increase the risk of electric shock!

!WARNING

Serious injury could occur if you connect the machine to power before completing the setup process. DO NOT connect to power until instructed later in this manual.

Extension Cords

Since this machine must be permanently connected to the power supply, an extension cord cannot be used.



SECTION 3: SETUP

Unpacking

Your machine was carefully packaged for safe transportation. Remove the packaging materials from around your machine and inspect it. If you discover any damage, *please call us immediately at (570) 546-9663 for advice.*

Save the containers and all packing materials for possible inspection by the carrier or its agent. *Otherwise, filing a freight claim can be difficult.*

When you are completely satisfied with the condition of your shipment, inventory the contents.



Needed for Setup

The following are needed to complete the setup process, but are not included with your machine.

Description	Qty
• Additional People	1
• Safety Glasses	1
• Cleaner/Degreaser	As Needed
• Disposable Shop Rags.....	As Needed
• Forklift.....	1
• Straightedge 4'	1
• Screwdriver Phillips #2	1
• Screwdriver Flat Head #2.....	1
• Dust Collection System	1
• Dust Hose 5"	1
• Hose Clamps 4"	2
• Pressurized Air Supply	At least 75 PSI

Inventory

The following is a list of items shipped with your machine. Before beginning setup, lay these items out and inventory them.

If any non-proprietary parts are missing (e.g. a nut or a washer), we will gladly replace them; or for the sake of expediency, replacements can be obtained at your local hardware store.

- Sanding Unit
- Tool Box
- Combo Wrench 8/10MM
- Combo Wrench 11/13MM
- Combo Wrench 12/14MM
- Combo Wrench 17/19MM
- Combo Box-Wrench 30/37MM
- Phillips Screwdriver
- Hex Wrench Set
- Platen Puller
- Platen
- Door Handle (2)
- Handwheel Handle
- Sanding Belt #180
- Sanding Belt #240

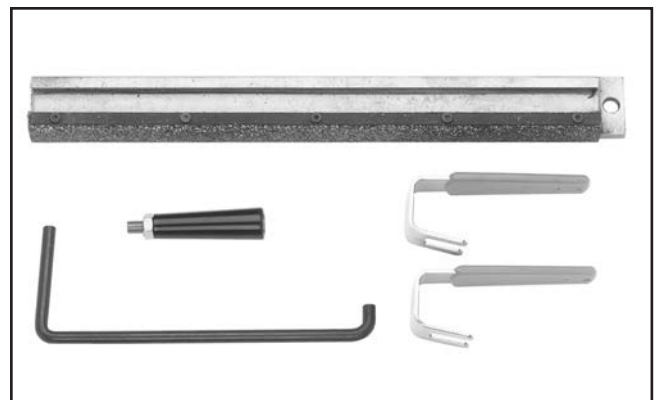

Figure 6. Loose parts (not including hardware) for the Model G9983.



Cleanup

The unpainted surfaces of your machine are coated with a heavy-duty rust preventative that prevents corrosion during shipment and storage. This rust preventative works extremely well, but it will take a little time to clean.

Be patient and do a thorough job cleaning your machine. The time you spend doing this now will give you a better appreciation for the proper care of your machine's unpainted surfaces.

There are many ways to remove this rust preventative, but the following steps work well in a wide variety of situations. Always follow the manufacturer's instructions with any cleaning product you use and make sure you work in a well-ventilated area to minimize exposure to toxic fumes.

Before cleaning, gather the following:

- Disposable Rags
- Cleaner/degreaser (WD•40 works well)
- Safety glasses & disposable gloves
- Plastic paint scraper (optional)

Basic steps for removing rust preventative:

1. Put on safety glasses.
2. Coat the rust preventative with a liberal amount of cleaner/degreaser, then let it soak for 5–10 minutes.
3. Wipe off the surfaces. If your cleaner/degreaser is effective, the rust preventative will wipe off easily. If you have a plastic paint scraper, scrape off as much as you can first, then wipe off the rest with the rag.
4. Repeat **Steps 2–3** as necessary until clean, then coat all unpainted surfaces with a quality metal protectant to prevent rust.

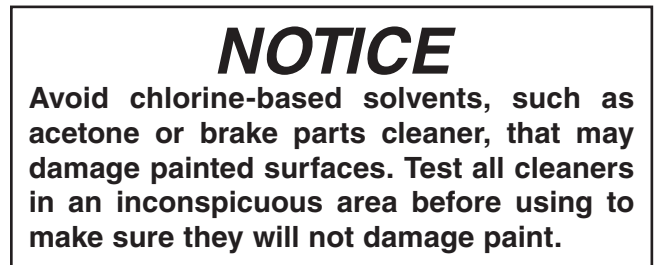
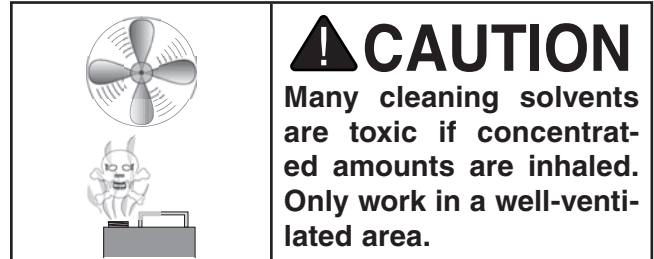
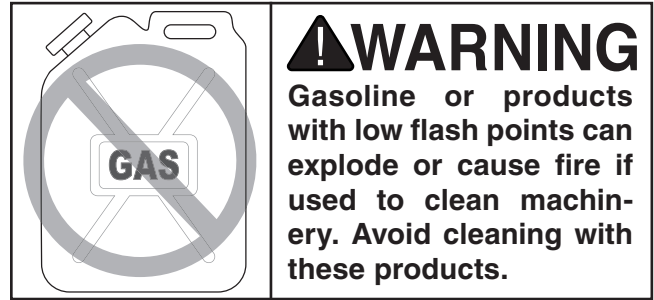

T23692—Orange Power Degreaser

A great product for removing the waxy shipping grease from your machine during clean up.



Figure 7. T23692 Orange Power Degreaser.



Site Considerations

Weight Load

Refer to the **Machine Data Sheet** for the weight of your machine. Make sure that the surface upon which the machine is placed will bear the weight of the machine, additional equipment that may be installed on the machine, and the heaviest workpiece that will be used. Additionally, consider the weight of the operator and any dynamic loading that may occur when operating the machine.

Space Allocation

Consider the largest size of workpiece that will be processed through this machine and provide enough space around the machine for adequate operator material handling or the installation of auxiliary equipment. With permanent installations, leave enough space around the machine to open or remove doors/covers as required by the maintenance and service described in this manual. **See below for required space allocation.**

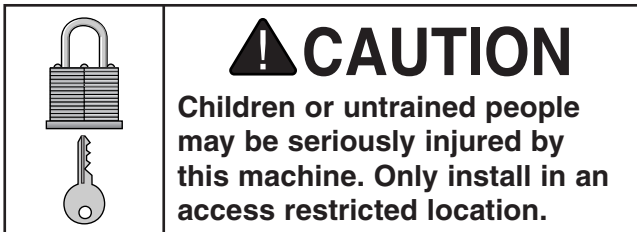

Physical Environment

The physical environment where the machine is operated is important for safe operation and longevity of machine components. For best results, operate this machine in a dry environment that is free from excessive moisture, hazardous chemicals, airborne abrasives, or extreme conditions. Extreme conditions for this type of machinery are generally those where the ambient temperature range exceeds 41°–104°F; the relative humidity range exceeds 20–95% (non-condensing); or the environment is subject to vibration, shocks, or bumps.

Electrical Installation

Place this machine near an existing power source. Make sure all power cords are protected from traffic, material handling, moisture, chemicals, or other hazards. Make sure to leave access to a means of disconnecting the power source or engaging a lockout/tagout device, if required.

Lighting

Lighting around the machine must be adequate enough that operations can be performed safely. Shadows, glare, or strobe effects that may distract or impede the operator must be eliminated.



Mounting

Although not required, we recommend that you mount your new machine to the floor. Because this is an optional step and floor materials may vary, floor mounting hardware is not included.

Bolting to Concrete Floors

Lag shield anchors with lag screw and anchor studs (**Figure 8**) are two popular methods for anchoring an object to a concrete floor. We suggest you research the many options and methods for mounting your machine and choose the best that fits your specific application.

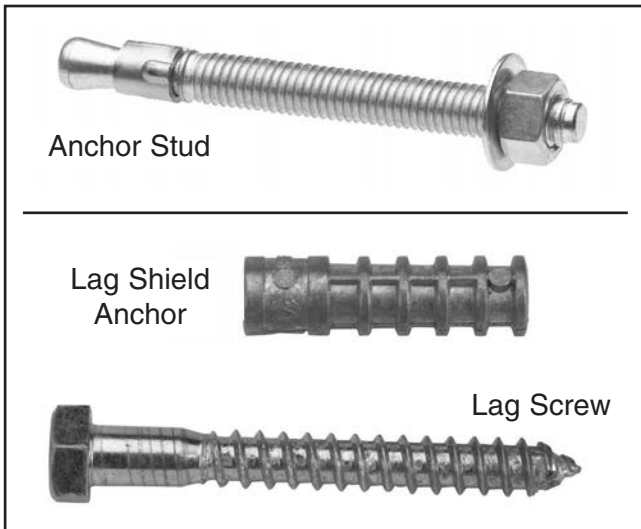

Figure 8. Typical fasteners for mounting to concrete floors.

NOTICE

Anchor studs are the strongest option, but they stick out of the floor—permanently. Before using, make sure you have enough clearance to lift the machine over the studs if it must be moved in the future.

NOTICE

Unless otherwise specified by your local codes, this machine **MUST** be secured to the floor if it is permanently connected (hardwired) to the power supply.



Assembly

⚠️ WARNING

Serious injury could occur if you connect the machine to power before completing the setup process. DO NOT connect to power until instructed later in this manual.

Most of your new wide-belt sander has been assembled at the factory, but some setup is required after delivery. We have organized the setup process into steps. Please make sure the sander is placed in its final position in your shop and follow along in the order presented in this section.

Installing Handwheel Handle

1. Thread the handle into the handwheel as shown in **Figure 9**.
2. After handle is completely threaded down, tighten the jam nut so the handle will not come loose. Make sure to leave the plastic sleeve loose enough to rotate when you crank the handwheel.



Figure 9. Install handle onto handwheel.

NOTICE

The waxy grease must be completely cleaned from the table column for smooth table height adjustments.

Installing Platen

The housing for the platen can be accessed by opening the door on the left-hand side of the machine.

A graphite sheet is mounted on the platen. Before installing, make sure that the graphite sheet is mounted on the left-hand side of the platen, as it will be inserted. Figure 8 shows the platen being installed correctly.

The direction of the graphite sheet is important because it must wrap around the platen in the same direction as the sanding belt rotates. If not, the sanding belt will unwrap the graphite sheet, exposing the sanding belt to the metal body of the platen.

Note: *The graphite sheet on the platen is considered a “consumable” item, similar to the sanding belts, and normal wear and tear from machine operation is not covered under warranty.*

To insert the platen:

1. Line up the platen dovetail with the housing so it is positioned as described above.
2. Slide the platen into the housing as far as it can go (see **Figure 10**).



Figure 10. Install the platen with the graphite sheet on the left-hand side.



The platen must now be set even with the sanding rollers.

To set the platen even with the belt rollers:

1. Lower the conveyor table as far as it will go.
2. Open the access door on the left-hand side and locate the platen adjustment knob shown in **Figure 11**.



Figure 11. Use this knob to raise/lower the platen.

3. Place a straightedge across both lower belt rollers and rotate the adjustment knob until the platen barely touches the straightedge. The platen should now be set even with the belt rollers.

Connecting Air Hose

The air hose connection is located at the regulator on the front of the machine.

To connect the air hose:

1. Fit the hose over the regulator nozzle.
2. Secure the hose with a hose clamp as shown in **Figure 12** and turn on your air compressor.
3. Regulate the air pressure to 75 PSI. This is the normal operating pressure for the Model G9983.



Figure 12. Secure air hose with a hose clamp.

NOTICE

DO NOT exceed 75 lbs. of air pressure. Damage to the machine components may result.

NOTICE

The main shut off valve should remain closed until air pressure is needed. This will reduce wear and tear on the air system components.



Installing Sanding Belt

The Model G9983 is designed for 16" x 48" sanding belts.

To install a sanding belt:

1. Open the left-hand side door for access.
2. Make sure the greasy protective coating has been cleaned from the metal belt roller before installing sanding belt.
3. Fit the sanding belt completely over the three sanding rollers as shown in **Figure 13**.

Note: *The belt will move counter-clockwise during rotation—make sure that the arrows on the inside of the belt point in the direction of rotation.*



Figure 13. Place belt over the three belt rollers to install. Make sure arrows on inside of belt point in the direction of rotation.

Sanding Belt Tension

The sanding belt tension is controlled by a switch located inside the upper portion of the machine (see **Figure 14**). To locate it, open the access door on the left-hand side of the sander.

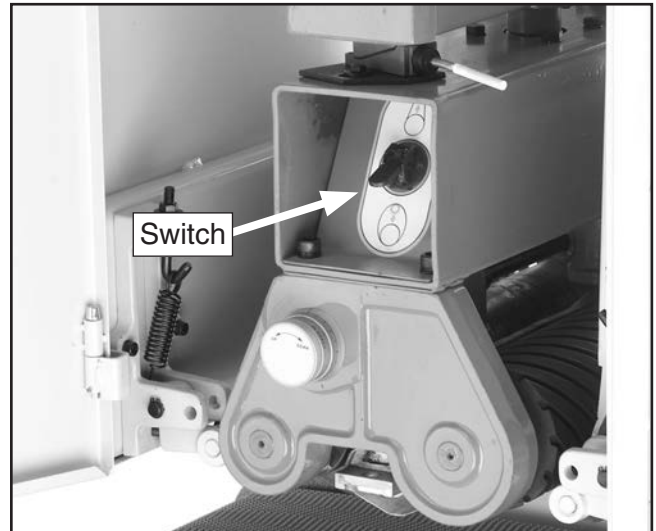

Figure 14. This is the belt tension switch.

To Tighten Belt Tension:

Flip the switch up. The vertical cylinder will automatically tighten the top roller to the correct tension.

To Loosen Belt Tension:

Flip the switch down. The vertical cylinder will automatically loosen the belt tension for belt removal.

NOTICE

The belt tension switch is part of the air control system. This means the machine must have air pressure for the switch to work correctly.

NOTICE

Always tighten belt before starting sander!



Pressure Rollers

The pressure rollers have been set at the factory, but for increased personal safety, you should verify that they are below the sanding belt.

WARNING

Always keep the pressure rollers set below the level of the sanding roller. If the pressure rollers are even, or higher than the sanding roller, the workpiece **WILL** be propelled from the sander at a high rate of speed. This situation could cause serious personal injury.

To check the feed pressure:

1. Place a piece of scrap wood of uniform thickness across the conveyor so it spans both front and rear pressure rollers at the same time.
2. Make sure the platen is even with the sanding belt rollers.
3. With the air pressure connected, the sanding belt installed, and the belt tension switch ON, slowly raise the conveyor and verify that the board touches both pressure rollers before it touches the sanding belt.

—If the board does not touch both pressure rollers before it touches the sanding belt, then the pressure rollers must be adjusted before operation. See Section 8: Service Adjustments for step-by-step instructions on how to do this.

Dust Collection

CAUTION

This machine creates substantial amounts of dust during operation. Breathing airborne dust on a regular basis can result in permanent respiratory illness. Reduce your risk by wearing a respirator and capturing the dust with a dust collection system.

Recommend CFM at Dust Port: 1200 CFM

Do not confuse this CFM recommendation with the rating of the dust collector. To determine the CFM at the dust port, you must consider these variables: (1) CFM rating of the dust collector, (2) hose type and length between the dust collector and the machine, (3) number of branches or wyes, and (4) amount of other open lines throughout the system. Explaining how to calculate these variables is beyond the scope of this manual. Consult an expert or purchase a good dust collection "how-to" book.

The dust collection port is located on top of the sander and measures 5" in diameter. It will be necessary to attach a 5" dust collection pipe over this port before operation. If you have rigid ducts in your dust collection system, we recommend that you connect the ducts to your sander with flexible hose. The flex-hose easily attaches with a 5" hose clamp and it absorbs any movement that may occur during operation. Please refer to the Grizzly catalog for current price and ordering information.



Power Connection

Before the machine can be connected to the power source, an electrical circuit and connection device must be prepared per the **POWER SUPPLY** section in this manual; and all previous setup instructions in this manual must be complete to ensure that the machine has been assembled and installed properly. The disconnect switch installed by the electrician (as recommended) is the primary means for disconnecting or connecting the machine to the power source.

Connecting to Power Source

Move the disconnect switch handle to the ON position, as illustrated below. The machine is now connected to the power source.

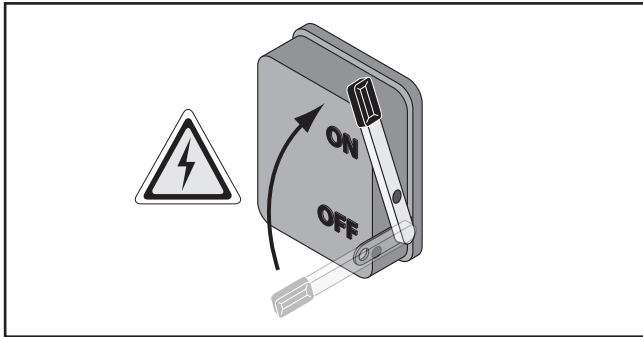

Figure 15. Connecting power to machine.

Disconnecting from Power Source

Move the disconnect switch handle to the OFF position, as illustrated below. The machine is now disconnected from the power source.

Note: Lock the switch in the OFF position to restrict others from starting the machine.

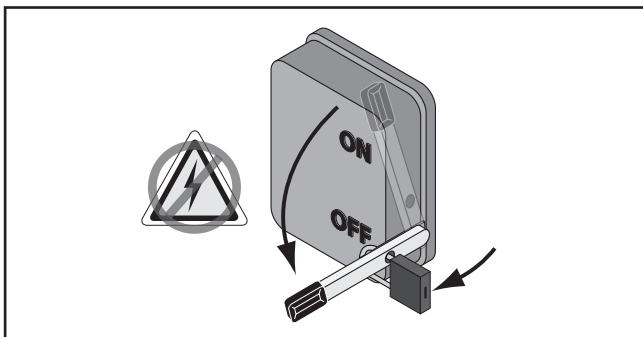

Figure 16. Disconnecting power from machine.

Test Run

Once the assembly is complete, test run your machine to make sure it runs properly.

If, during the test run, you cannot easily locate the source of an unusual noise or vibration, stop using the machine immediately, then review the **Troubleshooting on Page 28**.

If you still cannot remedy a problem, contact our Tech Support at (570) 546-9663 for assistance.

To test run the machine:

1. Make sure you have read the safety instructions at the beginning of the manual and that the machine is set up properly.
2. Make sure all tools and objects used during setup are cleared away from the machine.
3. Make sure the machine is connected to an air compressor and the pressure gauge on the sander reads 75 PSI.
4. Turn ON the power supply at the main panel, then start both the sanding belt and the feed belt.
5. Listen to and watch for abnormal noises or actions. The machine should run smoothly with little or no vibration or rubbing noises.

—Strange or unusual noises should be investigated and corrected before operating the machine further. Always disconnect the machine from power when investigating or correcting potential problems.
6. Turn the machine **OFF**.



Recommend Adjustments

For your convenience, the adjustments listed below have been performed at the factory and no further setup is required to operate your machine.

However, because of the many variables involved with shipping, we recommend that you at least check the following adjustments to ensure the best possible results from your new machine.

All of these adjustments are covered in step-by-step detail in beginning in the **SERVICE** section beginning on **Page 28**.

Recommended adjustment checklist:

- Pressure Rollers
- Oscillation Timing
- Oscillation Speed
- Oscillation Return
- Limit Switch Position
- Feed Belt Tension
- Feed Belt Tracking
- V-Belt Tension



SECTION 4: OPERATIONS

Operation Overview

The purpose of this overview is to provide the novice machine operator with a basic understanding of how the machine is used during operation, so the machine controls/components discussed later in this manual are easier to understand.

Due to the generic nature of this overview, it is **not** intended to be an instructional guide. To learn more about specific operations, read this entire manual and seek additional training from experienced machine operators, and do additional research outside of this manual by reading "how-to" books, trade magazines, or websites.

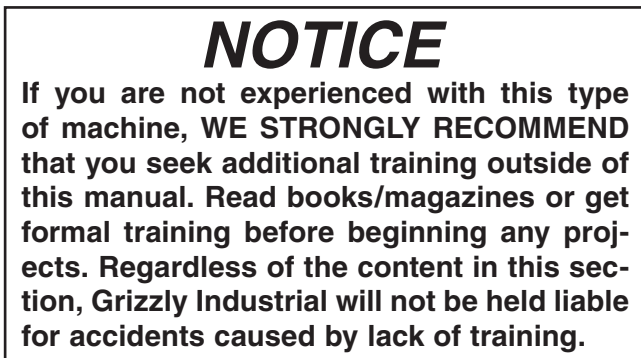
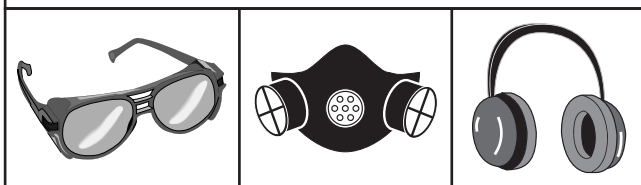
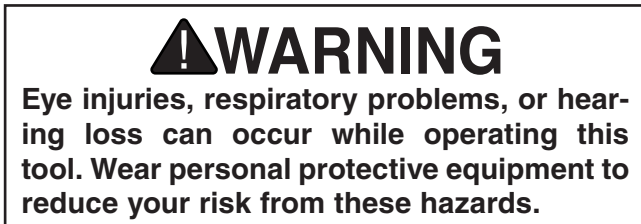

To complete a typical operation, the operator does the following:

1. Examines the workpiece to make sure it is suitable for sanding.
2. Puts on the recommended personal protective equipment.
3. Starts the dust collector.
4. Makes the thickness adjustment by placing the workpiece on the conveyor table and turns the conveyor handle until the workpiece can be sanded and fed through smoothly.
5. Turns **ON** the main power supply, then the sanding and conveyor motors.
6. Slowly feeds the workpiece onto the conveyor belt, then releases the workpiece when it is feeding through the sander.
7. Stands to the side of the machine and removes the workpiece from the sander as it exits from the rear.
8. Turns the sanding and conveyor motors **OFF**.



Choosing Sandpaper

The Model G9983 takes 16"W x 48"L sanding belts.

The grit you choose will depend on the type of work, the species of wood and the stage of finishing. Below is a chart that groups abrasives into different classes and shows which grits fall into each class. We recommend using aluminum oxide for best results.

Grit	Type
60	Coarse
80–100	Medium
120–150	Fine

The general rule of thumb is to sand a workpiece with progressively higher grit numbers, with no one grit increase of more than 50.

Ultimately, the type of wood you use and your stage of finish will determine the best grit types to install on your sander.

Conveyor Belt Height

Conveyor height is controlled by turning the handwheel shown in **Figure 17**. A scale is located near the handwheel for gauging conveyor movement. The scale is marked in millimeters and inches. **Figure 18** demonstrates how the handwheel movement affects the conveyor.

After you have moved the conveyor to the desired height, lock it in place with the conveyor lock handle shown in **Figure 17**.

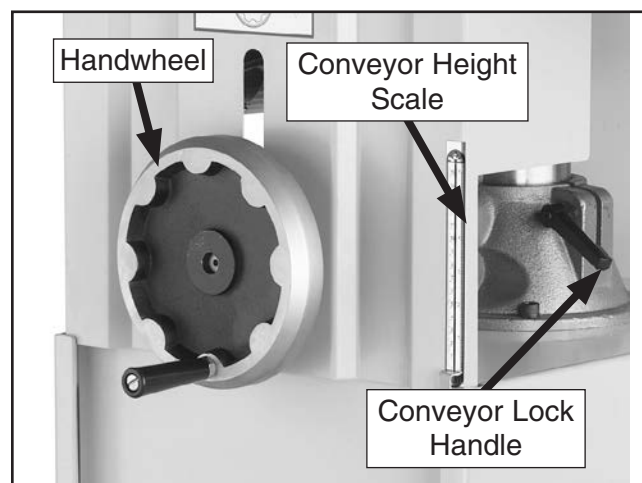

Figure 17. The handwheel moves the conveyor and the scale tells you how far the conveyor moved.

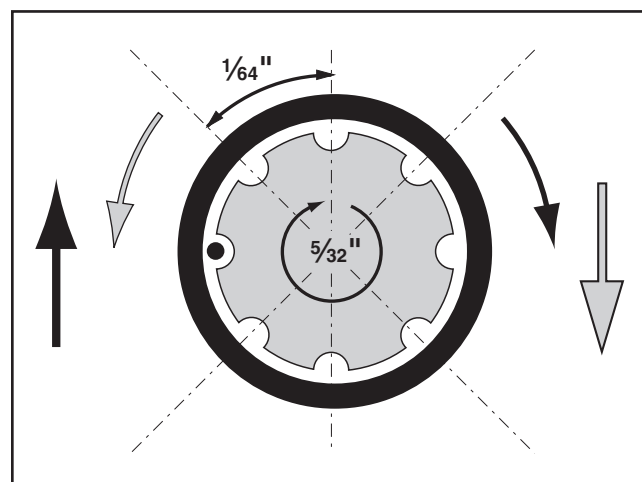

Figure 18. This illustration shows how the handwheel moves the conveyor.



Feed Belt Speed

The feed belt motor (shown in **Figure 19** with the cover removed) controls the speed of the feed belt. The Model G9983 features speeds of 13.1 FPM and 16.4 FPM.

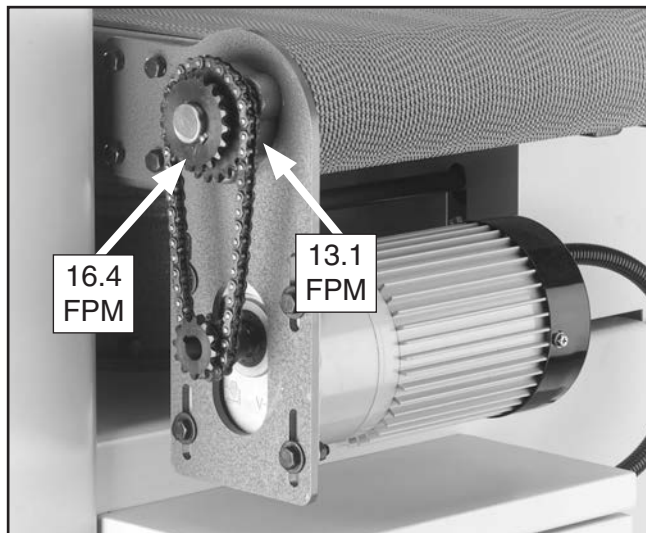

Figure 19. This is the feed belt motor. Place the chain on either of the sprockets and the feed belt will travel at the speed shown.

To change feed belt speeds:

1. DISCONNECT SANDER FROM POWER!
2. Remove the cap screw that secures the feed belt motor cover.
3. Loosen the for motor mount bolts so that the motor will slide up enough to get the chain off the sprockets.
4. Determine which speed is best for your application and place the chain on either set of the sprockets shown in **Figure 19**.
5. Replace the motor cover and secure it with the cap screw.

Load Meter

The load meter shown in **Figure 20** displays the current amperage draw of the sanding belt motor. The needle rises when you increase the load on the sanding belts and decreases when you decrease the load. Use this meter to avoid overloading your machine with too heavy of a cut.

NEVER exceed 30 amps—this is the maximum that your machine can safely handle!

Since various types of stock will react differently to various loads, use trial-and-error to determine the best settings for your applications. As a general rule, always start with a small load and work your way up. **DO NOT** push your machine to its maximum load; instead, use multiple passes or install a coarser grit paper.



Figure 20. This is the load meter.

	<p>⚠ CAUTION Long term exposure to this machine while operating may cause hearing loss. Wear approved hearing protection to minimize this risk!</p>
--	--



Platen Depth

The platen position allows for 3 types of operation. These different positions can be adjusted by rotating the knob shown in **Figure 21**. Notice that the knob has a scale on it. By keeping track of how many revolutions you have rotated the knob, you can determine how far you have moved the platen.



Figure 21. The scale on this knob tells you how far you have moved the platen.

The three basic platen positions:

Platen Up: The platen is raised above the level of the sanding rollers. This position allows the front roller to remove large amounts of material quickly, but leaves a rough finish. The best belt grit for this position is #100 or coarser.

Platen Even: The platen is set even with the sanding rollers. The rollers work together with the platen to produce intermediate/final finishing. The best belt grit for this position is #100-#180.

Platen Down: The platen is lowered below the sanding rollers. The majority of the work is accomplished by the platen pressure on the workpiece. The result is a smooth, flat finish. The best belt grit for this position is #180 or finer.

Note: *Avoid Lowering the platen more than .2MM below the sanding belt rollers—this is the equivalent to 1 full turn of the knob.*



SECTION 5: ACCESSORIES

! WARNING

Installing unapproved accessories may cause machine to malfunction, resulting in serious personal injury or machine damage. To reduce this risk, only install accessories recommended for this machine by Grizzly.

NOTICE

Refer to our website or latest catalog for additional recommended accessories.

H2845—PRO-STICK® Sanding Pad

Extend the life of your sandpaper! Just feed this crepe-rubber cleaning pad through your drum sander to remove dust build-up from the sandpaper without damage. 15" X 20" X 1 1/8"



Figure 22. PRO-STICK® sanding pad.

16" x 48" Aluminum Oxide Sanding Belts

These belts use tough aluminum oxide grain, open coated on a very heavy Y-weight polyester backing with a resin bond system that no equivalent product can outperform—and they can be washed to further the savings!

- H4173—60 Grit
- H4174—80 Grit
- H4175—100 Grit
- H4176—120 Grit
- H4177—150 Grit

G8982—Shop Fox Roller Table

Use this versatile roller table wherever you need extra workpiece support. Features all steel welded construction and measures 19" x 65" long. Comes with 9 ball bearing rollers and has four independently adjustable legs for any leveling requirement. Adjustable in height from 26 3/8" to 44 1/8".



Figure 23. G8982 Shop Fox roller table.

G0562Z—3 HP Dust Collector

This powerful dust collector has a canister filter with 6 times the filtering area of regular bags and has a built-in cleaner. The heavy-duty steel adapter allows three 4" lines to be connected simultaneously. With just a glance at the bottom clear-plastic bags, you will know when it is time to empty them.

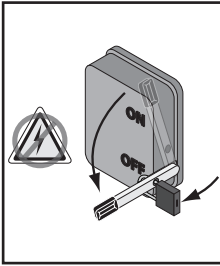

Figure 24. Model G0562Z Dust Collector.

order online at www.grizzly.com or call 1-800-523-4777



SECTION 6: MAINTENANCE



!WARNING

To reduce risk of shock or accidental startup, always disconnect machine from power before adjustments, maintenance, or service.

Schedule

For optimum performance from your machine, follow this maintenance schedule and refer to any specific instructions given in this section.

Daily Check:

- Loose mounting bolts.
- Check/clean/replace sanding belt.
- Check/empty air regulator filters.
- Worn or damaged cords, plugs or switch.
- Damaged V-belt.
- Any other condition that could hamper the safe operation of this machine.

Cleaning

Cleaning the Model G9983 is relatively easy. Vacuum excess wood chips and sawdust, and wipe off the remaining dust with a dry cloth. If any resin has built up, use a resin dissolving cleaner to remove it. Use a sanding pad to clean the sanding belt on a regular basis (see the previous page for an option from Grizzly).

Lubrication

Moving parts, such as chains, should be lubricated periodically with a light machine oil. Do not use too much lubrication because excess can attract dirt and sawdust and will clog the chain mechanism.

Emptying Regulator Filters

There are two filters on the Model G9983. The first filter is located under the main regulator that houses the pressure gauge. The second filter, shown in **Figure 25**, is located near the oscillation controls. Since the eye fork configuration is prone to collecting sawdust, check and empty this filter often.



Figure 25. Unscrew this filter to empty it.



SECTION 7: SERVICE

Review the troubleshooting and procedures in this section if a problem develops with your machine. If you need replacement parts or additional help with a procedure, call our Technical Support at (570) 546-9663.

Note: Please gather the serial number and manufacture date of your machine before calling.

Troubleshooting

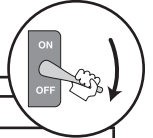

Symptom	Possible Cause	Possible Solution
Motor will not start; fuses or circuit breakers blow.	<ol style="list-style-type: none"> 1. Low voltage. 2. Open circuit in motor or loose connections. 3. Short circuit in line cord or plug. 4. Short circuit in motor or loose connections. 5. Incorrect fuses or circuit breakers in power line. 	<ol style="list-style-type: none"> 1. Check power line for proper voltage. 2. Inspect all lead connections on motor for loose or open connections. 3. Inspect cord or plug for damaged insulation and shorted wires. 4. Inspect all connections on motor for loose or shorted terminals or worn insulation. 5. Install correct fuses or circuit breakers.
Motor overheats.	<ol style="list-style-type: none"> 1. Motor overloaded. 2. Air circulation through the motor restricted. 3. Short circuit in motor or loose connections. 4. Low voltage. 5. Incorrect fuses or circuit breakers in power line. 	<ol style="list-style-type: none"> 1. Reduce load on motor. 2. Clean out motor to provide normal air circulation. 3. Inspect connections on motor for loose or shorted terminals or worn insulation. 4. Correct the low voltage conditions. 5. Install correct fuses or circuit breakers.
Machine slows when operating.	<ol style="list-style-type: none"> 1. Feed rate too high. 2. Depth of cut too great. 	<ol style="list-style-type: none"> 1. Feed workpiece slower and watch load meter. 2. Reduce depth of cut and watch load meter.
Loud, repetitious noise coming from machine	<ol style="list-style-type: none"> 1. Pulley set screws or keys are missing or loose. 2. Motor fan is hitting the cover. 3. V-belt is defective. 	<ol style="list-style-type: none"> 1. Inspect keys and set screws. Replace or tighten if necessary. 2. Tighten fan or shim cover. 3. Replace V-belt. See Maintenance section.
Machine is loud, overheats or bogs down in the cut.	<ol style="list-style-type: none"> 1. Excessive depth of cut. 2. Dull sanding belt. 	<ol style="list-style-type: none"> 1. Decrease depth of cut. 2. Replace sanding belt.
Edges of wood are rounded.	<ol style="list-style-type: none"> 1. Excessive depth of cut. 	<ol style="list-style-type: none"> 1. Reduce depth of cut.
Uneven thickness from left to right of board.	<ol style="list-style-type: none"> 1. Feed table not parallel to sanding roller. 2. Feed belt is worn. 	<ol style="list-style-type: none"> 1. Adjust the table. 2. Replace feed belt.
Workpiece slips on feed belt.	<ol style="list-style-type: none"> 1. Pressure rollers set too high. 2. Dirty feed belt. 3. Feed belt is worn. 	<ol style="list-style-type: none"> 1. Lower pressure rollers. 2. Clean feed belt. 3. Replace feed belt.
Straight strip of notches on workpiece.	<ol style="list-style-type: none"> 1. Pressure rollers are dirty or damaged. 	<ol style="list-style-type: none"> 1. Clean or repair pressure rollers.
Snake shaped marks on workpiece.	<ol style="list-style-type: none"> 1. Sanding belt damaged or dirty. 	<ol style="list-style-type: none"> 1. Clean or replace sanding belt.



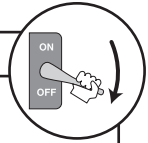

Symptom	Possible Cause	Possible Solution
Lines across width of workpiece.	1. Sanding belt seam is open or damaged.	1. Repair or replace sanding belt.
More material is removed from the end of workpiece than the length (snipe).	1. Workpiece is not supported as it comes out of sander. 2. Pressure rollers not set correctly.	1. Hold workpiece up with your hands as it comes out, or set up an outfeed table for your workpiece after it comes out. 2. Adjust the pressure rollers.
Glossy spots or streaks on workpiece.	1. Worn sanding belt. 2. Rear pressure roller too low.	1. Replace sanding belt. 2. Raise rear pressure roller.
Sanding belt clogs quickly.	1. Sanding belt grit too small for particular job. 2. Excessive depth of cut. 3. Wood is too moist.	1. Replace with a coarser grit sanding belt. 2. Reduce depth of cut. 3. Allow wood to dry out.
Sanding belt does not tension correctly; rollers slip under belt.	1. Low air pressure. 2. Air leaks in system.	1. Adjust air pressure to 75 PSI at primary regulator. 2. Inspect all hoses and connections for leaking air; use water on suspected area to detect bubbles.
Sanding belt runs off to one side, stopping the sander.	1. Air eye fork clogged. 2. Oscillation return valve closed. 3. Oscillation timing incorrect.	1. Clean the intake hole on the air eye fork. 2. Open valve. 3. Adjust oscillation timing.
Sanding belt will not start.	1. Sanding belt is not tensioned. 2. Limit switches engaged. 3. Emergency stop plate engaged.	1. Tension sanding belt. 2. Center sanding belt so it is not touching the limit switches. 3. Make sure emergency stop switch is released.
Poor, non-aggressive sanding results.	1. Platen adjusted incorrectly, above bottom surface level of lower sanding rollers. 2. Sanding belt loaded with sawdust. 3. Sanding belt worn out.	1. Adjust platen on the same plane as, or lower than, bottom surface level of lower rollers. 2. Clean sanding belt to unload sawdust. 3. Replace sanding belt with a new one.
Conveyor belt not tracking in center.	1. Conveyor rollers moved out of adjustment.	1. Re-adjust conveyor rollers.
Conveyor belt slipping.	1. Conveyor rollers have incorrect tension. 2. Conveyor rollers contaminated with dirt or dust.	1. Adjust conveyor rollers to increase tension. 2. Clean conveyor rollers.
Emergency brake stops slow.	1. Air pressure incorrect. 2. Air leak in system. 3. Brake rotor contaminated with oil. 4. Brake pads worn out.	1. Adjust air pressure to 75 PSI. 2. Find and fix air leaks. 3. Clean brake rotor with automotive brake parts cleaner. 4. Replace brake pads.
Grinding noise when braking.	1. Brakes severely worn out.	1. Replace brake pads, have rotor turned (possibly replaced).



Oscillation Timing

The first step in adjusting the oscillation is timing the side to side movement the belt makes when oscillating. The belt should take the same amount of time to travel to one side as it did the other.

⚠ CAUTION

Keep your hands clear of the sanding belt when making the adjustments during this procedure. The sandpaper is designed to remove a lot of material quickly whether it is wood or skin!

To time the oscillation movement:

1. Open both access doors to the upper part of the machine so you can view the belt movement. The sanding belt should also be on the rollers and tightened. Turn the sanding belt **ON**.
2. Count the amount of time it takes the belt to move from one side to the other. If the oscillation balance is correct, the belt will move from one side to the other in even intervals. If the balance is not correct, the belt may move to one side very quickly, then very slowly to the other.
3. If the belt immediately moves too far and shuts off the machine, then loosen the oscillation timing control knob shown in **Figure 26** and move it toward the front or rear of the machine to rotate the eccentric.



Figure 26. This is the oscillation timing control knob.

4. Loosen the belt tension, rebalance the sanding belt and retighten the belt tension. Repeat **Steps 2–3**.
5. When you get the belt to oscillate without stopping, experiment with the timing knob to see the effect its movement has on the belt oscillation.
6. Position the timing knob so the belt moves from one side to the other, back and forth, in even intervals.
7. Lock the knob in place by turning it clockwise.

Oscillation Speed

⚠ CAUTION

Keep your hands clear of the sanding belt when making the adjustments during this procedure. The sandpaper is designed to remove a lot of material quickly whether it is wood or skin!

Use the valve shown in **Figure 27** to control the speed of the sanding belt oscillation. Make sure the oscillation is balanced before adjusting the speed.



Figure 27. Use the knob on this valve to control oscillation speed.



To **increase** the oscillation speed, open the valve (turn the knob counter-clockwise). For normal operation, adjust the oscillation speed so each direction of belt movement takes approximately 2 seconds. When the speed is correct, tighten the jam nut so the knob will not move.

To **decrease** the oscillation speed, close the valve (turn the knob clockwise). When the speed is correct, tighten the jam nut.

Different speeds may yield different finishing results. Experiment with trial-and-error to determine the best speed for your particular situation.

Oscillation Return

The oscillation return keeps the sanding belt in motion. The valve shown in **Figure 28** controls the oscillation return.

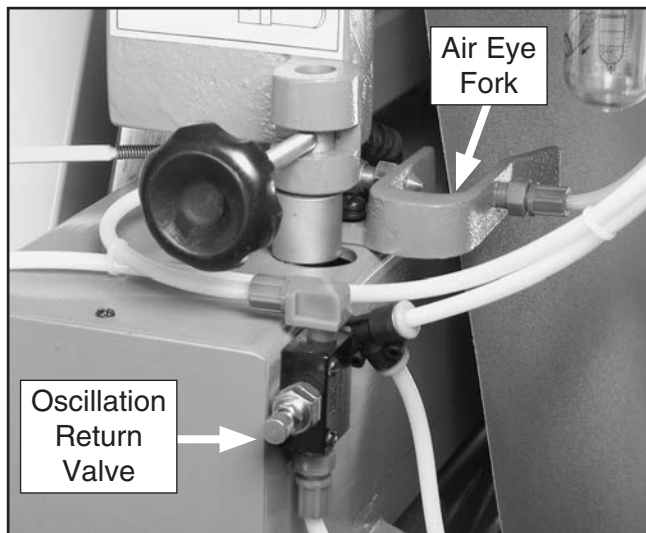

Figure 28. This is the oscillation return valve and the air eye fork.

To adjust the oscillation return:

1. Disconnect the sander from power, but keep air pressure going into the machine. Lower the belt and slide it out of the way of the eye fork.
2. Block the airflow between the eye fork until the top roller rotates to one side and does not return.
3. With the airflow still blocked, loosen the jam nut on the valve knob and tighten the knob to close the valve.
4. Now clear the eye fork so the air will flow between it again. Watch the top roller and slowly open the valve.
5. When the top roller begins to move, open the valve another $\frac{1}{4}$ to $\frac{1}{2}$ turn of the knob. Tighten the jam nut. **DO NOT** open the valve more than needed or there will be excessive pressure on the air system.



Limit Switches

The limit switches are mounted on both sides of the sanding belt. They are designed to stop the sander if the belt travels too far to one side of the top roller.

The limit switches are factory set and should require no adjustments. However, if they stop working correctly, they move during adjustments, or they get replaced, proper adjustments will be required.

To adjust the limit switches:

1. Center the sanding belt on the top roller. Measure the distance between the edge of the sanding belt and the limit switch lever. This distance should be approximately $\frac{1}{2}$ ". If this measurement is different, then loosen the adjustment bolts shown in **Figure 29** on the incorrect side.



Figure 29. Loosen these bolts to adjust the limit switch position.

2. Slide the mounting bracket in the necessary direction until there is a $\frac{1}{2}$ " gap between the edge of the belt and the limit switch lever.
3. Tighten the adjustment bolts to secure the mounting bracket. Test the sander to verify that operation returns to normal.

Pressure Roller Depth

Variables such as feed rate, depth of the cut, and type of sanding belt can play a big part in determining the proper amount of downward pressure exerted by the rollers. Some experimentation may be necessary with pressure roller spring tension to achieve the desired results. However, under no circumstances should the pressure roller depth be set even, or higher than, the sanding rollers or platen.

To adjust the pressure roller depth:

1. DISCONNECT SANDER FROM POWER!
2. Joint and plane a 6" W x 36"L piece of wood, then rip it down the middle. This will give you two boards that are nearly the exact same thickness.
3. Place one board along the length of the conveyor belt on the right-hand side so it is directly beneath both front and back pressure roller depth bolts. Place the other board on the left-hand side so it is directly beneath both front and back pressure roller depth bolts. **Figure 30** shows the front left-hand and front right-hand pressure roller adjustment bolts.

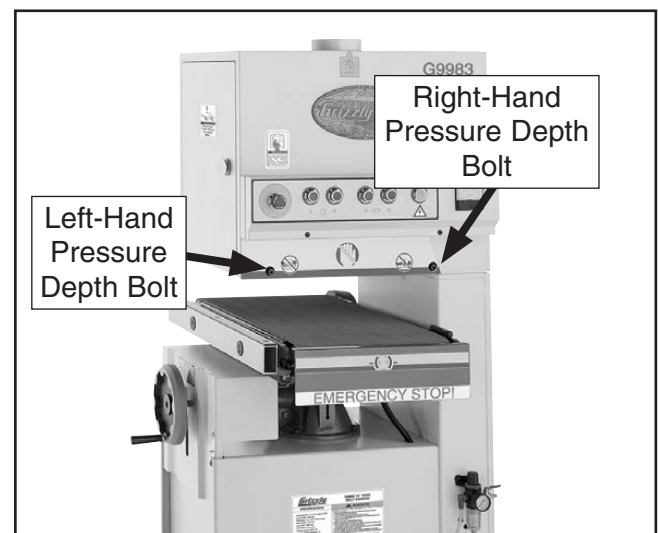

Figure 30. These are the pressure roller depth bolts at the front of the machine. *The rear depth bolts are in the same location at the rear.*



4. With the air pressure connected, and the sanding belt installed and tensioned, raise the pressure rollers above the sanding belt rollers.
5. Adjust the platen to be even with the bottom of the front sanding belt roller.
6. Raise the conveyor until the boards touch the front sanding belt roller and platen areas. The boards should evenly touch the front sanding belt roller and platen areas on both sides.
7. Turn the conveyor handwheel counterclockwise $\frac{1}{8}$ th of a turn. This should lower the conveyor approximately .020" or .5mm.
8. Lower each end of the pressure rollers so they barely touch the boards. Lock in place.

Pressure Roller Tension

Pressure roller tension is largely set by trial and error. If there is not enough tension, the workpiece will not pass through the sander evenly and may possibly be launched toward the operator. If there is too much tension, the feed belt will experience premature wear and the workpiece will pass through the sander sluggishly (if at all).

To adjust the pressure roller tension:

1. DISCONNECT SANDER FROM POWER!
2. Make sure the pressure roller depth is set correctly.
3. Open both access doors and locate the pressure roller tension springs shown in **Figure 31**.



Figure 31. This is one of the four pressure roller adjustment bolts.

4. Turning the nut on the adjustment bolt clockwise will increase the tension and counterclockwise will decrease the tension.

A quick way to gauge that the spring tension is consistent is to measure the distance from the top of the nut to the top of the adjustment bolt. If the board pulls to one side during sanding, loosen that side in small increments as needed.



Feed Belt Tension

To adjust the feed belt tension:

1. DISCONNECT SANDER FROM POWER!
2. Move the emergency brake plate up and out of the way.
3. Tension adjustments are made using the bolts located on the left and right side of the front conveyor roller as shown in **Figure 32**.
4. When tensioned properly you should not be able to lift the belt off the conveyor surface or slide it back and forth, and it should not slip.
5. Perform the “Feed Belt Tracking” instructions to ensure that the tracking did not change during tensioning.

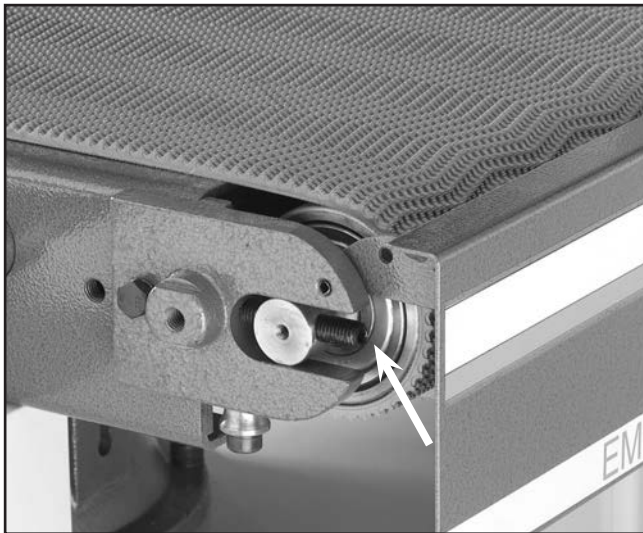

Figure 32. This is a feed belt adjustment bolt.

Feed Belt Tracking

To check the feed belt tracking:

1. Turn the feed belt **ON**.
2. If the belt moves to one side then you need to immediately stop the machine and adjust the belt tracking. If the belt tracks evenly, leave it alone.

To adjust the feed belt tracking:

1. DISCONNECT SANDER FROM POWER!
2. Use the adjustment bolts (one is shown in **Figure 32**) to correct the tracking.
3. Run the feed belt for a few minutes after the adjustment to allow the belt to move into its new position. When you are satisfied that the belt has finished moving, stop the feed belt.
4. If more adjustments are necessary, experiment with how the movement of the adjustment bolts affects the belt tracking; do this until you can make the feed belt track evenly. Make sure you did not loosen the belt during the tracking process. If you did, adjust each side of one belt roller away from the machine, as evenly as possible.



V-Belt Tension

The sanding belt is driven by two V-belts on the Model G9983. The V-belts must have adequate tension for proper power transmission. Proper tension is usually achieved when the V-belts can be deflected no more than 1" with moderate finger pressure at the midpoint between the wide-belt pulleys and the motor pulleys. The large cover on the right-hand side of the sander must be removed to access the V-belts and the sanding motor.

Thread the nuts shown in **Figure 33** down to tighten the V-belts, or thread the nuts up to loosen the V-belts.

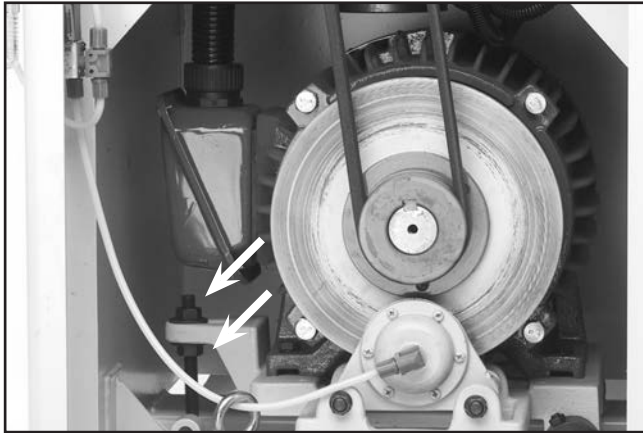

Figure 33. Turning these nuts allows you to raise/lower the motor to adjust the V-belts.

CAUTION

Always inspect V-belts for damage or deterioration when adjusting for tension. Should you find evidence of cracking, abrasion or damage from wood chips or other foreign materials, replace the belt immediately. Belt breakage may lead to mechanical damage or operator injury.

Replacing V-Belts

Inspect the V-belts closely; if you see any glazing, cracking or fraying, replace the belts. Always replace the two V-belts at the same time for proper power transmission.

To replace the V-belts:

1. DISCONNECT SANDER FROM POWER!
2. Shut the air pressure **OFF**.
3. Loosen the top nut on the motor adjustment bolt shown in **Figure 34**. Turn the bottom nut counterclockwise to raise the motor (or pry motor up with a scrap piece of wood) and loosen the V-belts.

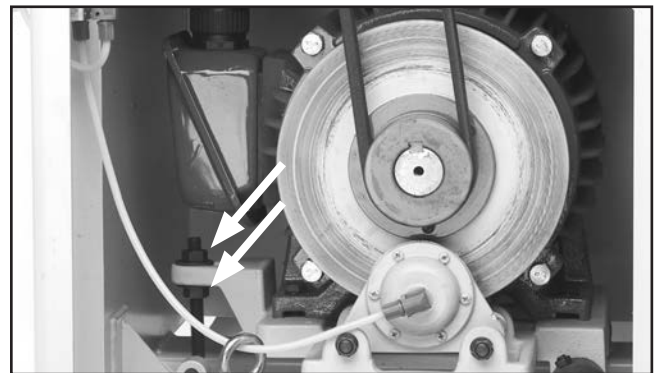

Figure 34. Loosen the V-belt by using the adjustment nuts.

4. When V-belts are sufficiently loose, slide them off of the motor pulley.



- To remove the V-belts from the roller pulley, the roller needs to be removed. Open the left-hand access door and remove the platen micro-adjust knob by loosening the setscrew that secures the face. The plate underneath the knob is secured to the casting by two setscrews—remove these. **Figure 35** shows the knob and indicator plate removed from the casting.
- Remove the large cap screws, also shown in **Figure 35**, to loosen the casting on the roller shafts.

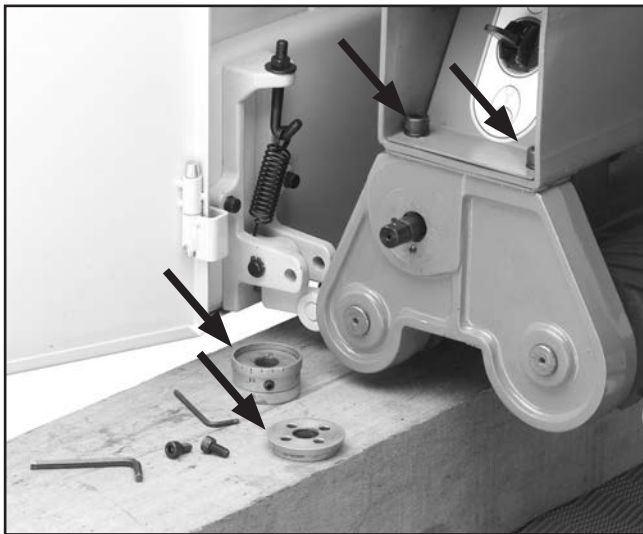

Figure 35. Remove platen adjustment knob, indicator plate, and large cap screws.

- Work the casting off the roller shafts as shown in **Figure 36**.



Figure 36. Work the casting off the roller shafts.

- Open the right-hand access door and locate the large nut shown in **Figure 37** and remove it with the box wrench included with the machine.

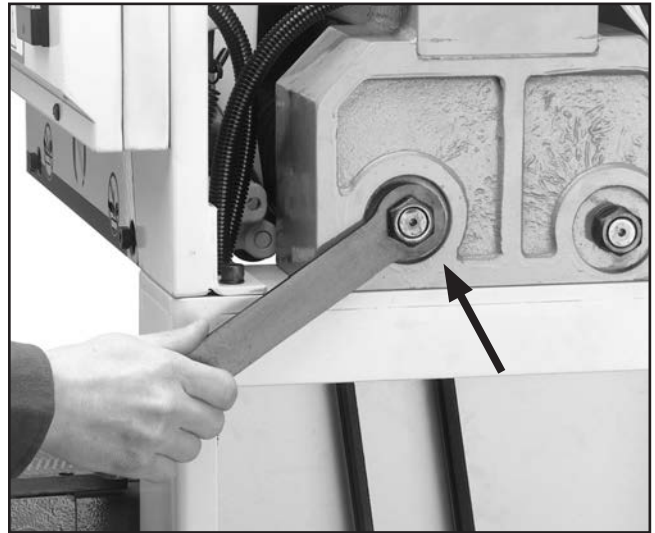

Figure 37. Remove this roller shaft nut located behind right-hand access door.

- Slide out the front roller shaft, as shown in **Figure 38**, to get the V-belts off of the pulley.



Figure 38. Remove roller.

- Installation is the reverse of removal. If possible, have an assistant help you when installing the V-belts and the roller. Also, an assistant can be helpful on the other end of the roller when tightening the nuts on the roller shafts.



Platen Graphite

The graphite sheet on the platen will wear out with use. Similar to the sanding belts, the graphite sheet is considered a “consumable” item and is not covered under the warranty. We recommend keeping replacements in your inventory to avoid downtime. To obtain replacements, use the part number in the back of this manual for ordering.

To replace the graphite sheet:

1. Pull the platen from its bracket with the included platen puller tool.
2. Remove the screws and hold-down bar that secure the graphite sheet to the platen.
3. Install the new graphite sheet exactly the reverse as removal. Make sure that the graphite sheet is wrapped in the same direction as the old one.

Air System

The air system is durable and reliable; however, components do wear with age. If you suspect that an item in your air system may be having problems, use the diagram on **Page 39** to follow all lines and connections, and use the instructions below to investigate.

- Carefully inspect all air lines for cracks, tears or hardening. Replace faulty hoses.
- Check the air connections for leaks. A small amount of water in a questionable area will bubble if there is a leak.
- Make sure lines are not clogged. Remove a questionable line and blow through it as a test.

CAUTION

If you ever determine that a component in the air system is malfunctioning, **DO NOT** operate the sander. Fix the problem before resuming operation.



Replacing Brakes

The only regular maintenance to perform on the brakes is to keep the rotor clean. This is a simple process and can be performed by spraying both sides of the rotor with automotive brake parts cleaner. The brake rotor must be free and clean of any dust, dirt, oil or moisture.

Eventually the brake pads will wear out. Checking and replacing these is a simple project that can be done in the shop, with the exception of having the rotor resurfaced.

To check the brake pads:

1. DISCONNECT SANDER FROM POWER!
2. Turn the air pressure **OFF** and remove any pressure in the system.
3. Remove the four screws that secure the motor cover on the right-hand side of the machine. This will allow you to access the brake components.
4. The brake pads consist of a metal plate with a composite pad. With a fine ruler, measure the thickness of the composite pad only. If one of the pads is below $\frac{1}{8}$ " (approx. 3mm), replace both.

To replace the brake pads:

1. DISCONNECT SANDER FROM POWER!
2. Turn the air pressure **OFF** and remove any pressure in the system.
3. Remove the nuts from the two mounting bolts. There are two snap rings on the mounting pins behind the bracket. Remove these.
4. Pull the mounting pins out of the caliper bracket and remove the air line from the caliper. The caliper should now be able to be removed as in **Figure 39**.

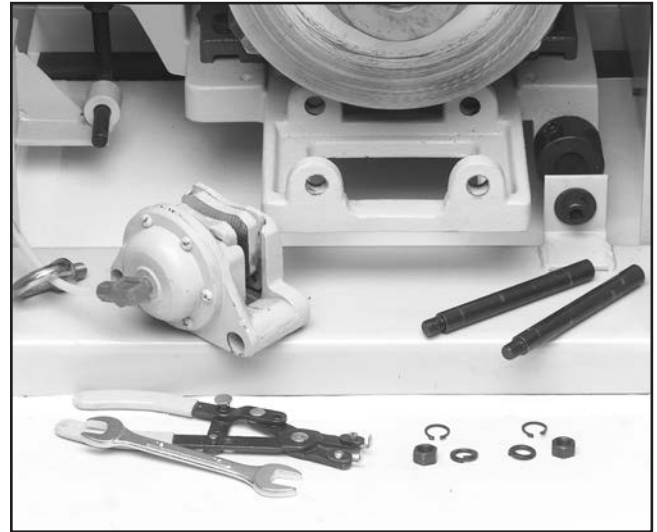

Figure 39. Removing caliper to replace brake pads.

5. The brake pads are secured to the caliper with cap screws. One of these screws is easily accessible; the other can only be reached by disassembling the brake caliper. Do this and remove the cap screws to remove the brake pads.
6. Remove the brake rotor and have it professionally resurfaced. For this, find a local machinist or auto supply store that regularly resurfaces brake rotors for automobiles. If visible cracks are present in the brake rotor, replace with a new one. Clean the rotor with automotive brake cleaner to remove any oil or dirt. Handle with a dry rag and install exactly the reverse of removal.
7. Install new brake pads, mount the caliper and reconnect the air line.



Air System

Various functions on the Model G9983 are controlled through the air system. Since this is a complex network of hoses and valves, please take some time to familiarize yourself with each item so you can better understand your machine during adjustments.

The illustration below follows the air travel through the machine to familiarize you with how it works. Match the letters in the text with those in the illustration to learn more about each function.

1. The air flows into the machine at the pressure regulator (A). This should be adjusted to 75 PSI.
2. The solenoid valve (C) controls the brake caliper (B) when signaled by the emergency stop switch or the limit switches.
3. The switching valve (E) controls the vertical cylinder (D) which raises/lowers the top roller (M) to tighten/loosen the sanding belt.
4. The valve (G) controls the air flow volume that goes to the air eye fork (F), which controls the belt oscillation return.
5. The diaphragm (H) actuates the switching valve (I) depending on whether air is coming from the eye fork (F) or the pressure regulator (A).
6. Switching valve (I) actuates the diaphragm (J), which controls oscillation arm (K), which in turn, moves eccentric shaft (L), which makes top roller (M) shift back and forth to control belt movement during operation.
7. Valve (O) controls the speed at which the belt moves back and forth.
8. Knob (N) allows you to rotate the eccentric shaft (L) to balance the oscillation timing so it takes the belt the same amount of time to move in one direction as it moves in the other direction.

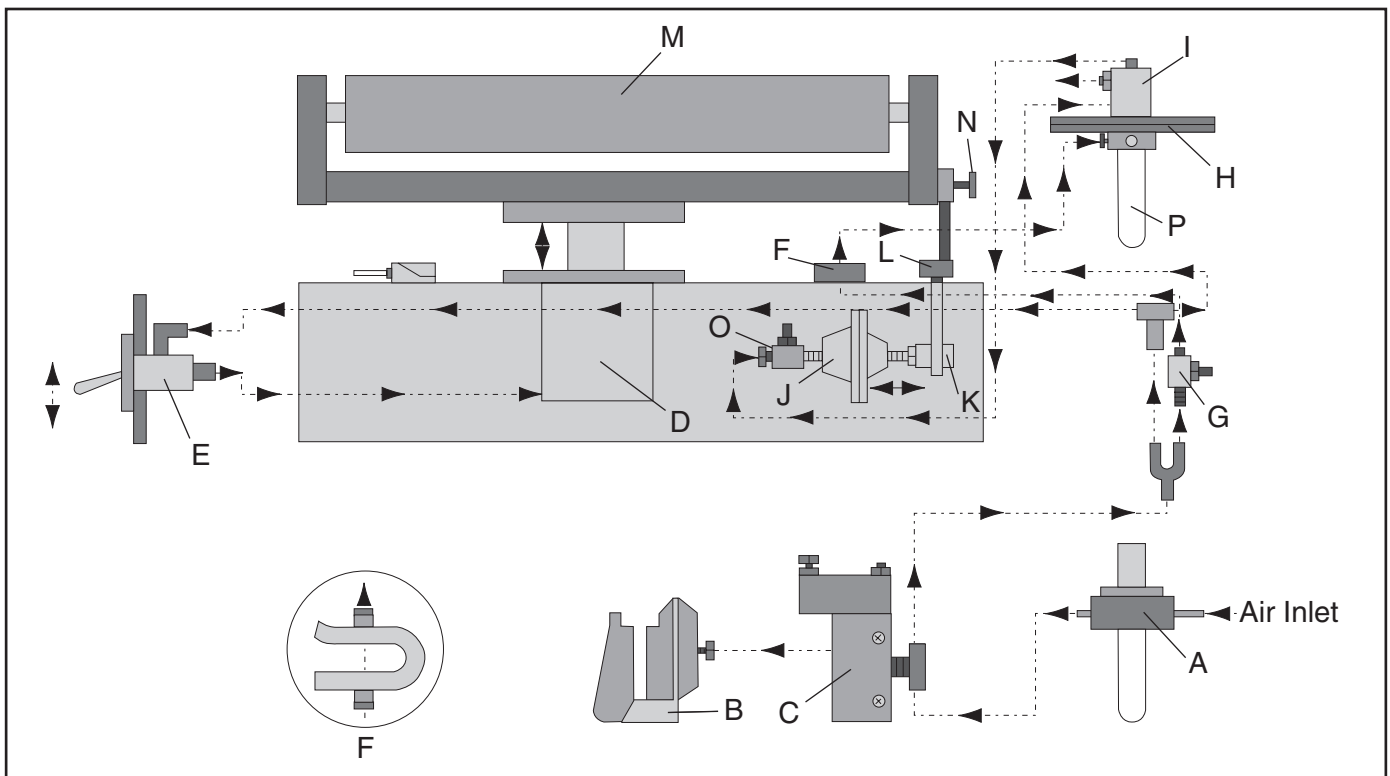

Figure 40. This is an illustration of the air control system.



SECTION 8: WIRING

These pages are current at the time of printing. However, in the spirit of improvement, we may make changes to the electrical systems of future machines. Compare the manufacture date of your machine to the one stated in this manual, and study this section carefully.

If there are differences between your machine and what is shown in this section, call Technical Support at (570) 546-9663 for assistance BEFORE making any changes to the wiring on your machine. An updated wiring diagram may be available. **Note:** *Please gather the serial number and manufacture date of your machine before calling. This information can be found on the main machine label.*

WARNING

Wiring Safety Instructions

SHOCK HAZARD. Working on wiring that is connected to a power source is extremely dangerous. Touching electrified parts will result in personal injury including but not limited to severe burns, electrocution, or death. Disconnect the power from the machine before servicing electrical components!

MODIFICATIONS. Modifying the wiring beyond what is shown in the diagram may lead to unpredictable results, including serious injury or fire. This includes the installation of unapproved after-market parts.

WIRE CONNECTIONS. All connections must be tight to prevent wires from loosening during machine operation. Double-check all wires disconnected or connected during any wiring task to ensure tight connections.

CIRCUIT REQUIREMENTS. You MUST follow the requirements at the beginning of this manual when connecting your machine to a power source.

WIRE/COMPONENT DAMAGE. Damaged wires or components increase the risk of serious personal injury, fire, or machine damage. If you notice that any wires or components are damaged while performing a wiring task, replace those wires or components.

MOTOR WIRING. The motor wiring shown in these diagrams is current at the time of printing but may not match your machine. If you find this to be the case, use the wiring diagram inside the motor junction box.

CAPACITORS/INVERTERS. Some capacitors and power inverters store an electrical charge for up to 10 minutes after being disconnected from the power source. To reduce the risk of being shocked, wait at least this long before working on capacitors.

EXPERIENCING DIFFICULTIES. If you are experiencing difficulties understanding the information included in this section, contact our Technical Support at (570) 546-9663.



Electrical Panel Wiring Diagram



WARNING!
SHOCK HAZARD!
 Disconnect power before working on wiring.

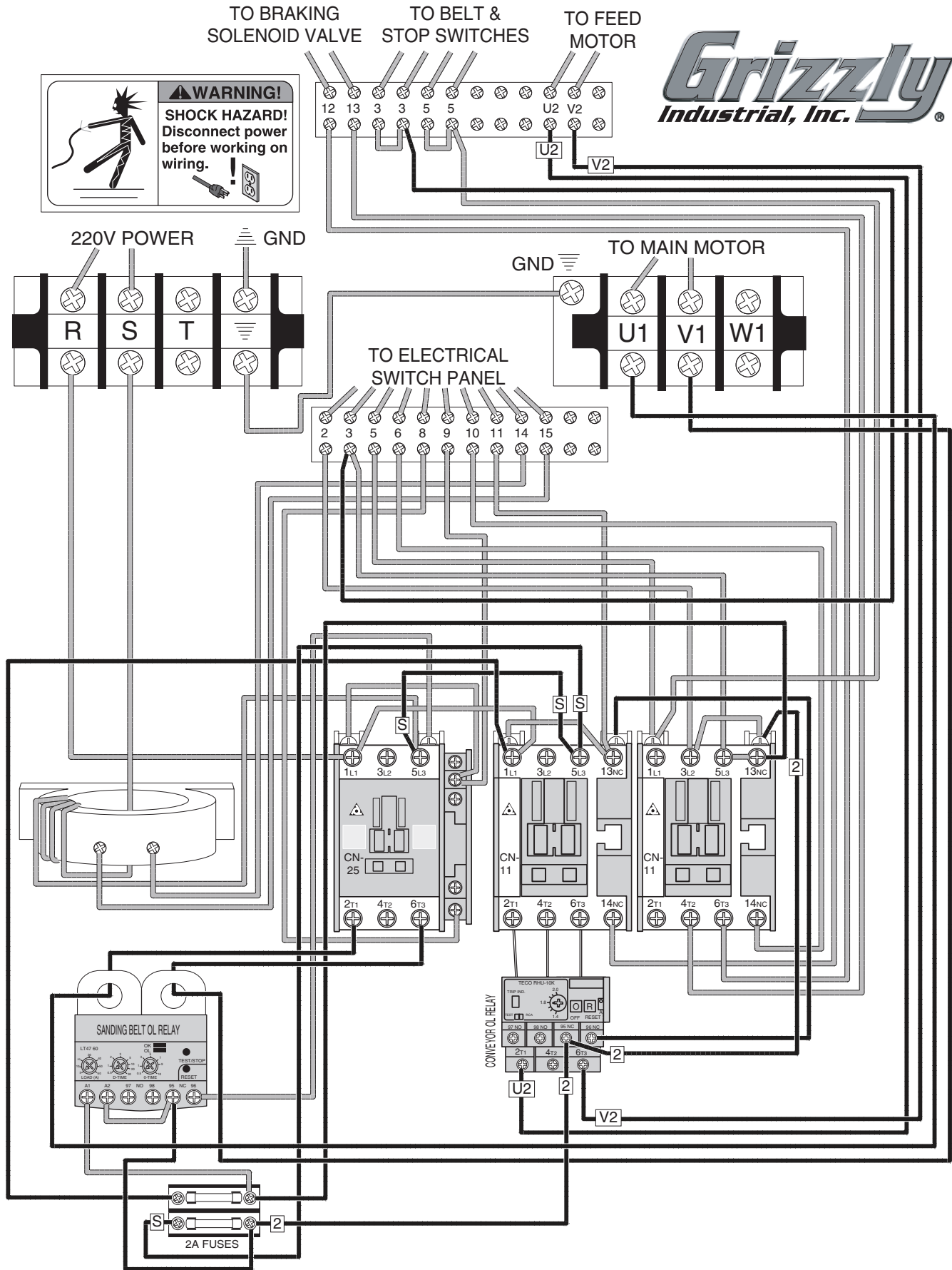

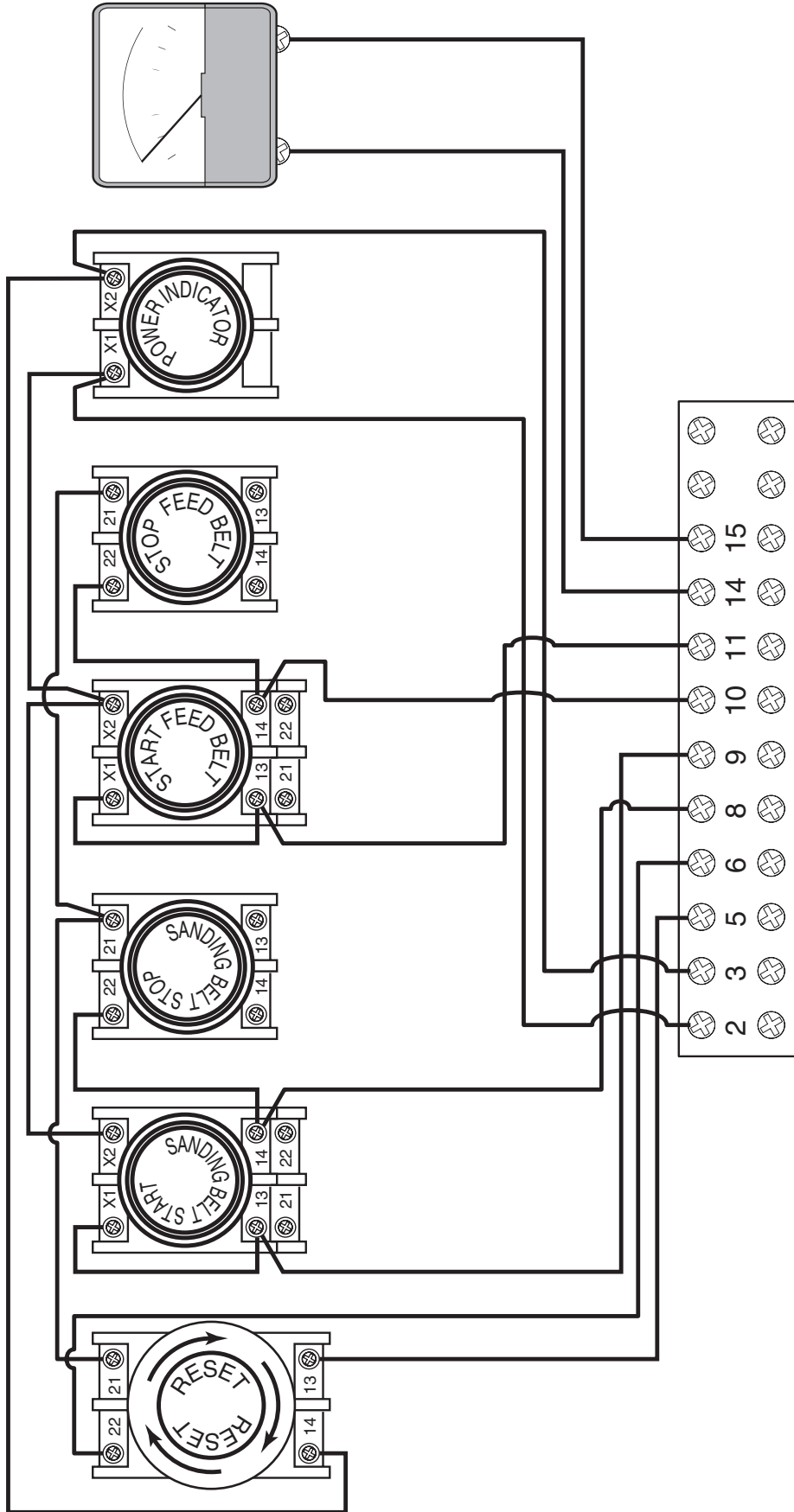

⚠ DANGER

Disconnect power from machine before performing any electrical service. Failure to do this will result in a shock hazard leading to injury or death.



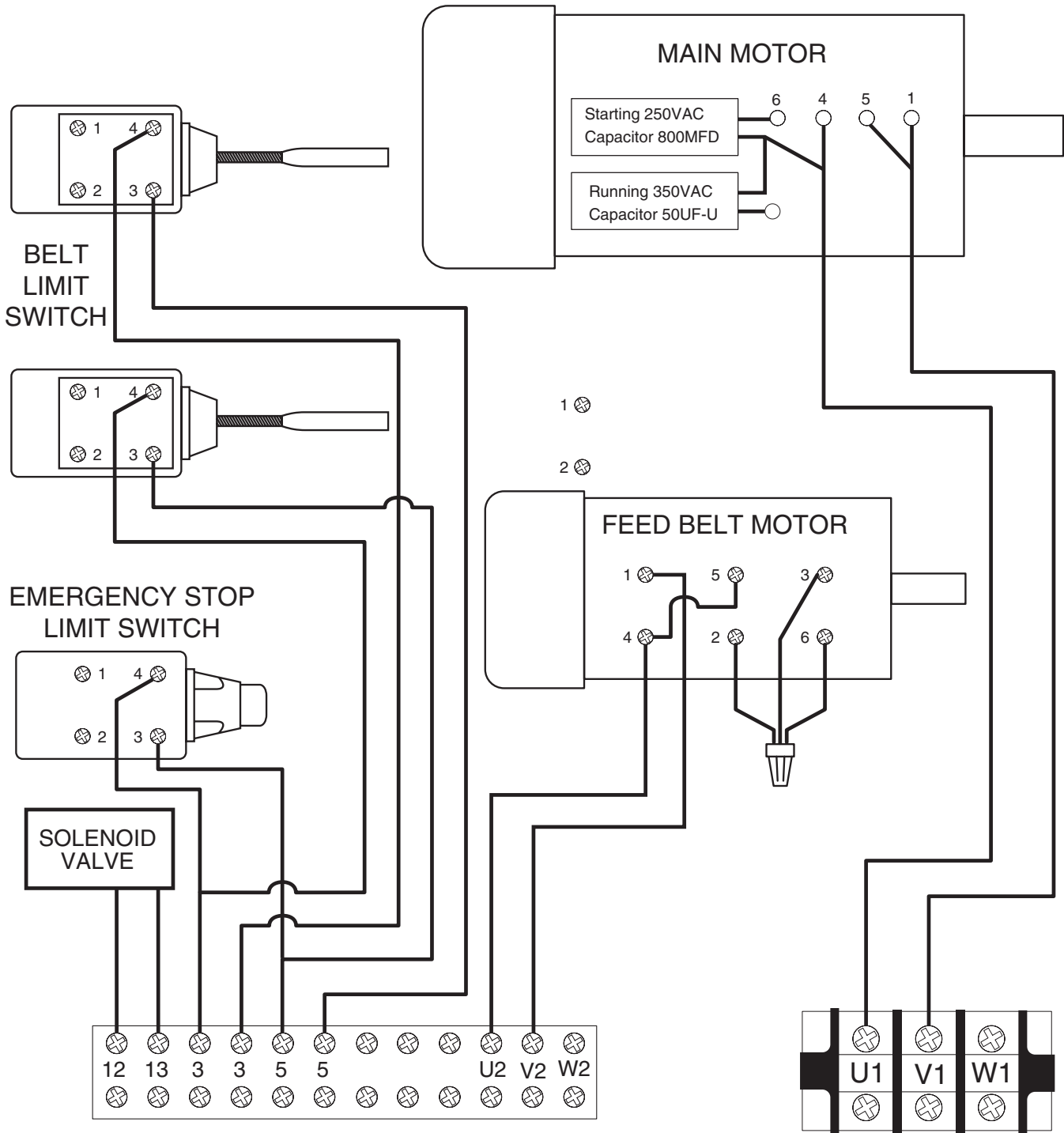

! DANGER
Disconnect power from machine before performing any electrical service. Failure to do this will result in a shock hazard leading to injury or death.



SECTION 9: PARTS

Please Note: We do our best to stock replacement parts whenever possible, but we cannot guarantee that all parts shown here are available for purchase. Call (800) 523-4777 or visit our online parts store at www.grizzly.com to check for availability.

Accessories

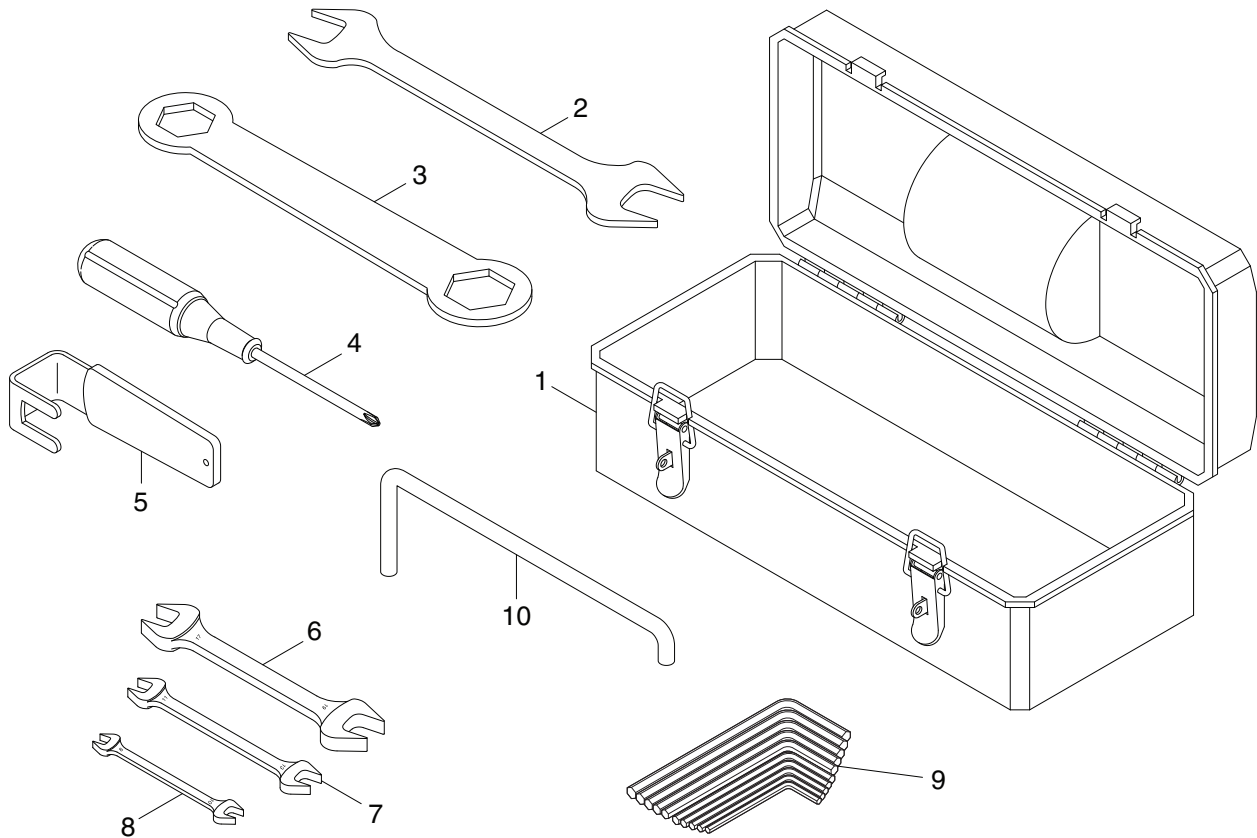

REF PART #	DESCRIPTION
1	P9983001 TOOL BOX
2	PWR1214 WRENCH 12 X 14MM OPEN-END
3	P9983003 FLAT WRENCH 30/37MM
4	PSDP2 PHLP HD SCREWDRIVER #2
5	P9983005 ACCESS DOOR HANDLE

REF PART #	DESCRIPTION
6	PWR1719 WRENCH 17 X 19MM OPEN-END
7	PWR1113 WRENCH 11 X 13MM OPEN-END
8	PWR810 WRENCH 8 X 10MM OPEN-END
9	PAW1510M HEX WRENCH 1.5-10MM 10PC SET
10	P9983010 PLATEN TOOL



Base & Sanding Motor

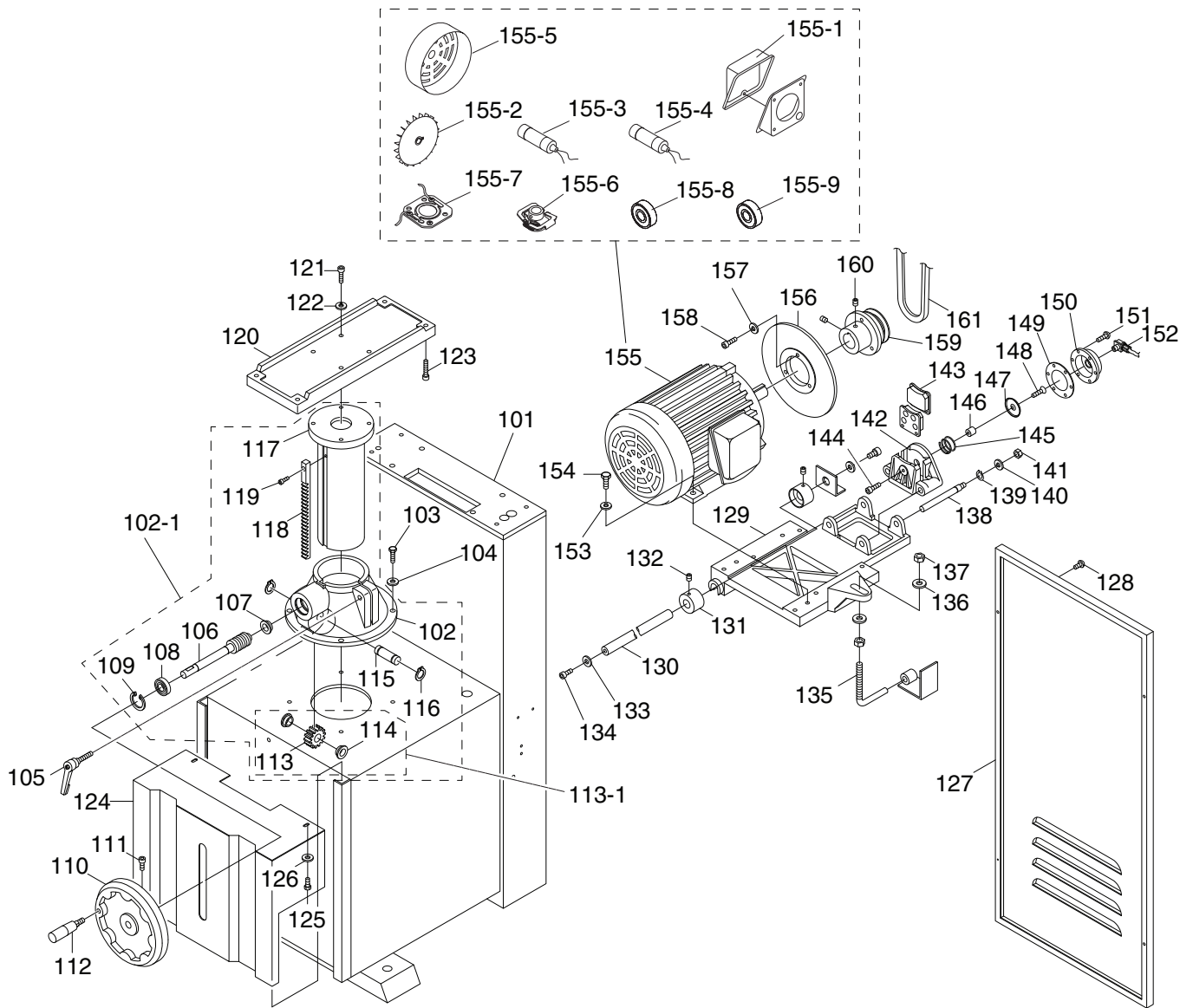

Base & Sanding Motor Parts List

REF	PART #	DESCRIPTION
101	P9983101	MACHINE BASE
102	P9983102	QUILL BASE
102-1	P9983102-1	QUILL ASSY
103	PCAP64M	CAP SCREW M10-1.5 X 25
104	PLW06M	LOCK WASHER 10MM
105	P9983105	ADJUSTABLE HANDLE
106	P9983106	WORM GEAR SHAFT
107	P51102	THRUST BEARING 51102
108	P6203ZZ	BALL BEARING 6203ZZ
109	PR23M	INT RETAINING RING 40MM
110	P9983110	HANDWHEEL
111	PCAP64M	CAP SCREW M10-1.5 X 25
112	P9983112	HANDLE M10
113	P9983113	WORM GEAR
113-1	P9983113-1	WORM GEAR ASSEMBLY
114	P9983114	WORM GEAR BUSHING
115	P9983115	GEAR SHAFT
116	PR18M	EXT RETAINING RING 17MM
117	P9983117	QUILL
118	P9983118	RACK
119	PCAP26M	CAP SCREW M6-1 X 12
120	P9983120	CONVEYOR SUPPORT
121	PCAP12M	CAP SCREW M8-1.25 X 40
122	PLW04M	LOCK WASHER 8MM
123	PCAP12M	CAP SCREW M8-1.25 X 40
124	P9983124	QUILL COVER
125	PS14M	PHLP HD SCR M6-1 X 12
126	PW03M	FLAT WASHER 6MM
127	P9983127	MACHINE REAR COVER
128	PS47M	PHLP HD SCR M6-1 X 25
129	P9983129	MOTOR BASE
130	P9983130	SETTING SHAFT
131	P9983131	LOCK BUSHING
132	PSS09M	SET SCREW M8-1.25 X 20
133	PW04M	FLAT WASHER 10MM
134	PCAP62M	CAP SCREW M10-1.5 X 12

REF	PART #	DESCRIPTION
135	P9983135	MOTOR MOUNT L-BOLT
136	PW06M	FLAT WASHER 12MM
137	PN09M	HEX NUT M12-1.75
138	P9983138	BRAKE PIN
139	PR47M	EXT RETAINING RING 13MM
140	PLW06M	LOCK WASHER 10MM
141	PN02M	HEX NUT M10-1.5
142	P9983142	BRAKE CALIPER
143	P9983143	BRAKE PAD 2-PC
144	PS14M	PHLP HD SCR M6-1 X 12
145	P9983145	COMPRESSION SPRING D34 X 15
146	P9983146	BRAKE AXLE
147	P9983147	SPRING COVER
148	PS47M	PHLP HD SCR M6-1 X 25
149	P9983149	GASKET
150	P9983150	TOP COVER
151	PS20M	PHLP HD SCR M5-.8 X 15
152	P9983514	PLASTIC CONNECTOR L6-1/8"
153	PLW06M	LOCK WASHER 10MM
154	PB01M	HEX BOLT M10-1.5 X 30
155	P9983155	SPINDLE MOTOR 5HP 220V 1-PH
155-1	P9983155-1	TERMINAL BOX
155-2	P9983155-2	MOTOR FAN
155-3	P9983155-3	S CAPACITOR 800M 250V 1-3/4 X 3-1/2
155-4	P9983155-4	R CAPACITOR 80M 350V 1-5/23 X 3-1/2
155-5	P9983155-5	MOTOR FAN COVER
155-6	P9983155-6	CENTRIFUGAL SWITCH
155-7	P9983155-7	CONTACT PLATE
155-8	P9983155-8	FRONT MOTOR BEARING
155-9	P9983155-9	REAR MOTOR BEARING
156	P9983156	BRAKE ROTOR
157	PLW06M	LOCK WASHER 10MM
158	PCAP75M	CAP SCREW M10-1.5 X 18
159	P9983159	MOTOR PULLEY
160	PSS13M	SET SCREW M10-1.5 x 12
161	PVA71	V-BELT A71



Conveyor

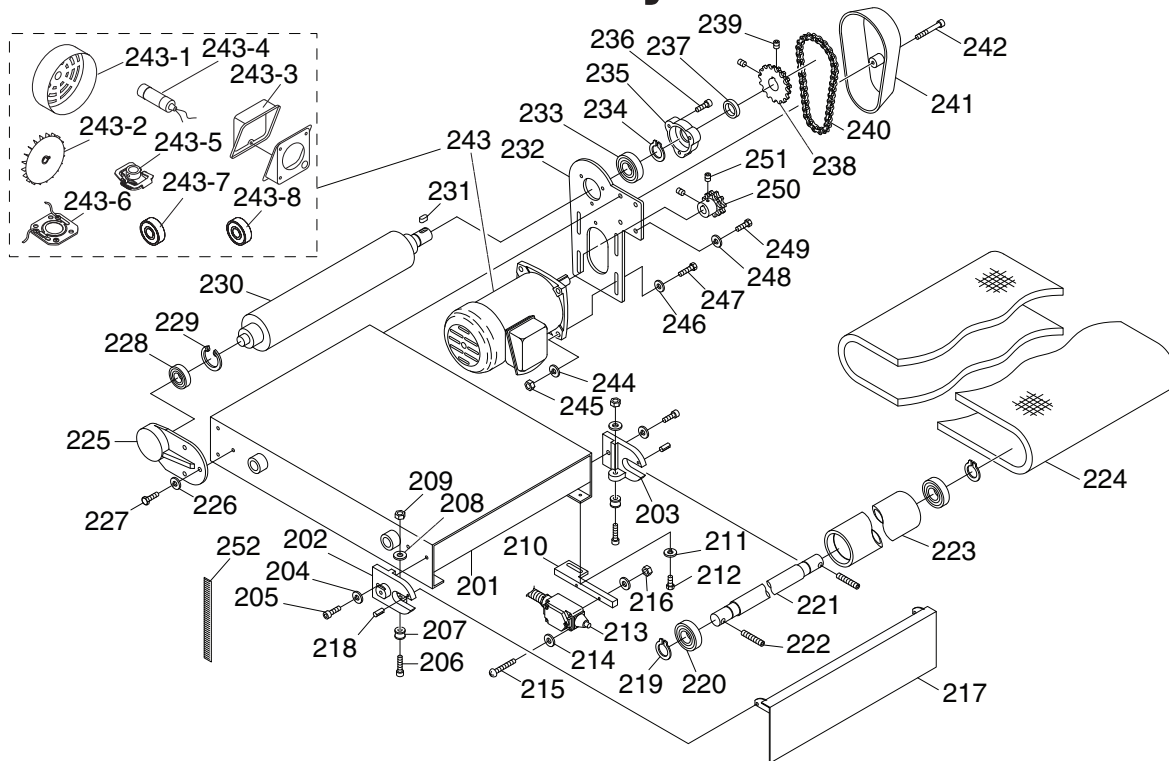

REF	PART #	DESCRIPTION
201	P9983201	CONVEYOR SUPPORT
202	P9983202	ROLLER BRACKET LH
203	P9983203	ROLLER BRACKET RH
204	PLW04M	LOCK WASHER 8MM
205	PB07M	HEX BOLT M8-1.25 X 25
206	PCAP40M	CAP SCREW M8-1.25 X 35
207	P9983207	PLASTIC ROLLER
208	PLW04M	LOCK WASHER 8MM
209	PN03M	HEX NUT M8-1.25
210	P9983210	LIMIT SWITCH BASE
211	PW03M	FLAT WASHER 6MM
212	PS14M	PHLP HD SCR M6-1 X 12
213	P9983213	LIMIT SWITCH
214	PW05M	FLAT WASHER 4MM
215	PS48M	PHLP HD SCR M4-.7 X 50
216	PN04M	HEX NUT M4-.7
217	P9983217	E-BRAKE PANEL
218	PRP03M	ROLL PIN 5 X 20
219	PR11M	EXT RETAINING RING 25MM
220	P6305ZZ	BALL BEARING 6305ZZ
221	P9983221	CONVEYOR AXLE
222	PSS39M	SET SCREW M10-1.5 X 50
223	P9983223	CONVEYOR ROLLER
224	P9983224	CONVEYOR BELT 380 X 1600MM
225	P9983225	BEARING SEAT
226	PLW04M	LOCK WASHER 8MM
227	PB09M	HEX BOLT M8-1.25 X 20
228	P6204ZZ	BALL BEARING 6204ZZ
229	PR25M	INT RETAINING RING 47MM
230	P9983230	MAIN ROLLER

REF	PART #	DESCRIPTION
231	PK67M	KEY 8 X 7 X 15
232	P9983232	MOTOR PANEL
233	P6205ZZ	BALL BEARING 6205ZZ
234	PR11M	EXT RETAINING RING 25MM
235	P9983235	BEARING COVER
236	PCAP74M	CAP SCREW M6-1 X 18
237	P9983237	BUSHING
238	P9983238	COMBO SPROCKET 19T/24T
239	PSS02M	SET SCREW M6-1 X 6
240	P9983240	CHAIN 3/8" X 48PC
241	P9983241	CHAIN COVER
242	PCAP37M	CAP SCREW M6-1 X 50
243	P9983243	FEED MOTOR 1/4HP 220V 1-PH
243-1	P9983243-1	MOTOR FAN COVER
243-2	P9983243-2	MOTOR FAN
243-3	P9983243-3	MOTOR JUNCTION BOX
243-4	P9983243-4	S CAPACITOR
243-5	P9983243-5	CENTRIFUGAL SWITCH
243-6	P9983243-6	CONTACT PLATE
243-7	P9983243-7	FRONT BALL BEARING
243-8	P9983243-8	REAR BALL BEARING
244	PLW04M	LOCK WASHER 8MM
245	PN03M	HEX NUT M8-1.25
246	PW01M	FLAT WASHER 8MM
247	PB26M	HEX BOLT M8-1.25 X 30
248	PLW04M	LOCK WASHER 8MM
249	PB09M	HEX BOLT M8-1.25 X 20
250	P9983250	COMBO SPROCKET 12T/14T
251	PSS02M	SET SCREW M6-1 X 6
252	P9983252	CONVEYOR HEIGHT SCALE



Sanding Belt Drive System

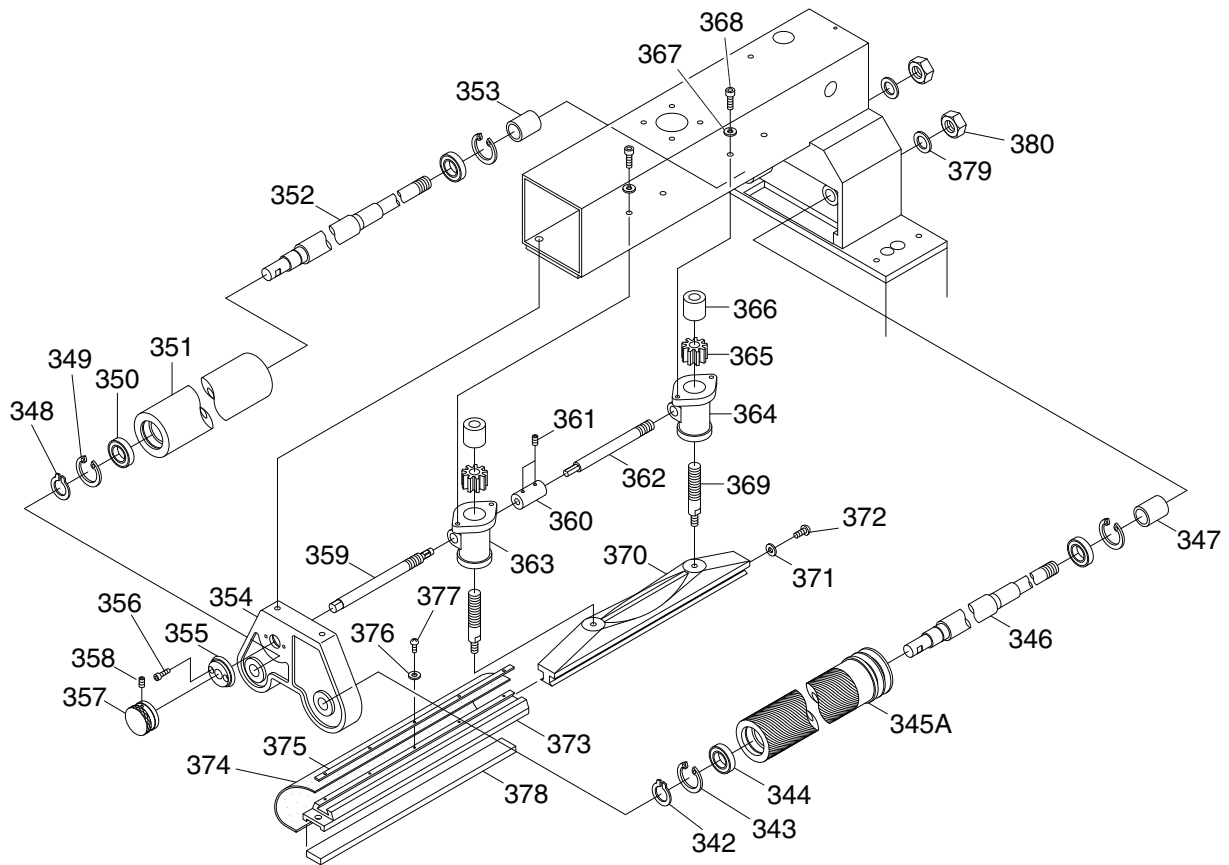
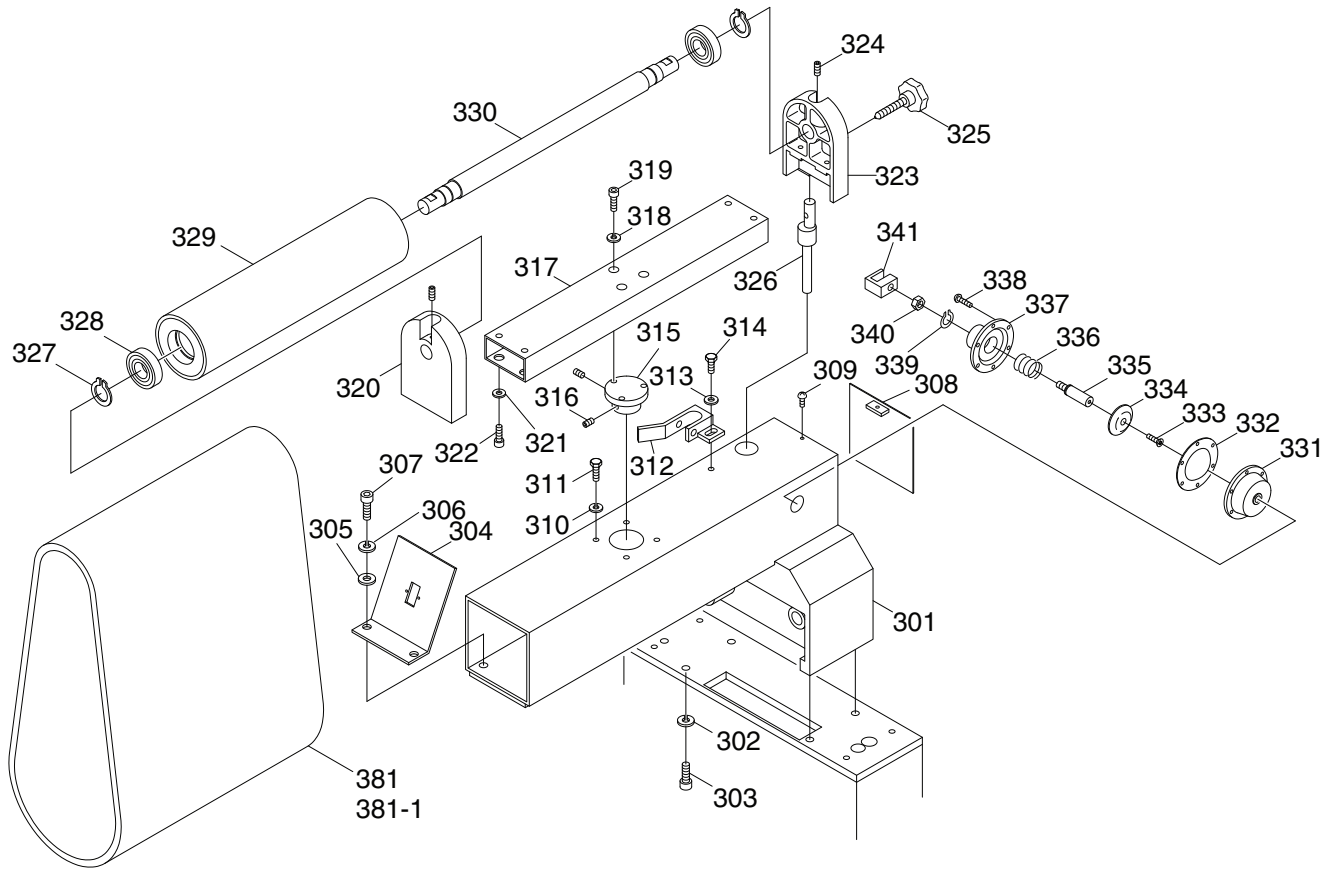

Sanding Belt Drive System Parts List

REF	PART #	DESCRIPTION
301	P9983301	CONTACT ROLLER BASE
302	PLW06M	LOCK WASHER 10MM
303	PCAP72M	CAP SCREW M10-1.5 X 30
304	P9983304	SWITCH PLATE
305	PW04M	FLAT WASHER 10MM
306	PLW06M	LOCK WASHER 10MM
307	PCAP72M	CAP SCREW M10-1.5 X 30
308	P9983308	COVER
309	PS02M	PHLP HD SCR M4-.7 X 12
310	PLW04M	LOCK WASHER 8MM
311	PB07M	HEX BOLT M8-1.25 X 25
312	P9983312	FORK
313	PW03M	FLAT WASHER 6MM
314	PS14M	PHLP HD SCR M6-1 X 12
315	P9983315	CYLINDER ROLLER FRAME
316	PSS04M	SET SCREW M6-1 X 12
317	P9983317	SUPPORT TUBE
318	PLW04M	LOCK WASHER 8MM
319	PCAP76M	CAP SCREW M8-1.25 X 18
320	P9983320	TOP ROLLER SUPPORT LH
321	PLW04M	LOCK WASHER 8MM
322	PCAP76M	CAP SCREW M8-1.25 X 18
323	P9983323	TOP ROLLER SUPPORT RH
324	PSS04M	SET SCREW M6-1 X 12
325	P9983325	KNOB BOLT M8-1.25 X 80
326	P9983326	ECCENTRIC SHAFT
327	PR11M	EXT RETAINING RING 25MM
328	P6205ZZ	BALL BEARING 6205ZZ
329	P9983329	TOP ROLLER
330	P9983330	TOP ROLLER SHAFT
331	P9983331	TOP COVER
332	P9983332	DIAPHRAGM
333	PFH02M	FLAT HD SCR M6-1 X 12
334	P9983334	SPRING COVER
335	P9983335	SHAFT
336	P9983336	COMPRESSION SPRING D25 X 24
337	P9983337	BOTTOM COVER
338	PS06M	PHLP HD SCR M5-.8 X 20
339	PR05M	EXT RETAINING RING 15MM
340	PN02M	HEX NUT M10-1.5
341	P9983341	OSCILLATION SQUARE

REF	PART #	DESCRIPTION
342	PR11M	EXT RETAINING RING 25MM
343	PR25M	INT RETAINING RING 47MM
344	P6005ZZ	BALL BEARING 6005ZZ
345A	P9983345A	CONTACT ROLLER ASSEMBLY
346	P9983346	ROLLER SHAFT
347	P9983347	SLEEVE
348	PR11M	EXT RETAINING RING 25MM
349	PR25M	INT RETAINING RING 47MM
350	P6005ZZ	BALL BEARING 6005ZZ
351	P9983351	SUPPORT ROLLER
352	P9983352	ROLLER SHAFT
353	P9983353	BUSHING
354	P9983354	ROLLER BASE
355	P9983355	MICROMETER BASE
356	PCAP26M	CAP SCREW M6-1 X 12
357	P9983357	MICROMETER
358	PSS04M	SET SCREW M6-1 X 12
359	P9983359	MAIN WORM GEAR SHAFT
360	P9983360	CONNECTION COUPLING
361	PSS04M	SET SCREW M6-1 X 12
362	P9983362	SUPPORT WORM GEAR SHAFT
363	P9983363	GRAPHITE BASE LH
364	P9983364	GRAPHITE BASE RH
365	P9983365	WORM GEAR
366	P9983366	GEAR BUSHING
367	PLW04M	LOCK WASHER 8MM
368	PB03M	HEX BOLT M8-1.25 X 16
369	P9983369	VERT MICROMETER SCR M18-2.8 & M10-1.5
370	P9983370	PLATEN (MALE)
371	PW01M	FLAT WASHER 8MM
372	PCAP58M	CAP SCREW M8-1.25 X 12
373	P9983373	PLATEN (FEMALE)
374	P9983374	GRAPHITE CLOTH 3-3/8"W X 16-1/4"L
375	P9983375	SET PLATE
376	PW05M	FLAT WASHER 4MM
377	PS02M	PHLP HD SCR M4-.7 X 12
378	P9983378	LINING
379	PLW07M	LOCK WASHER 20MM
380	PN17M	HEX NUT M20-1.5
381	P9983381	SANDING BELT #180 16 X 48"
381-1	P9983381-1	SANDING BELT #240 16 X 48"



Sanding Cabinet & Air System

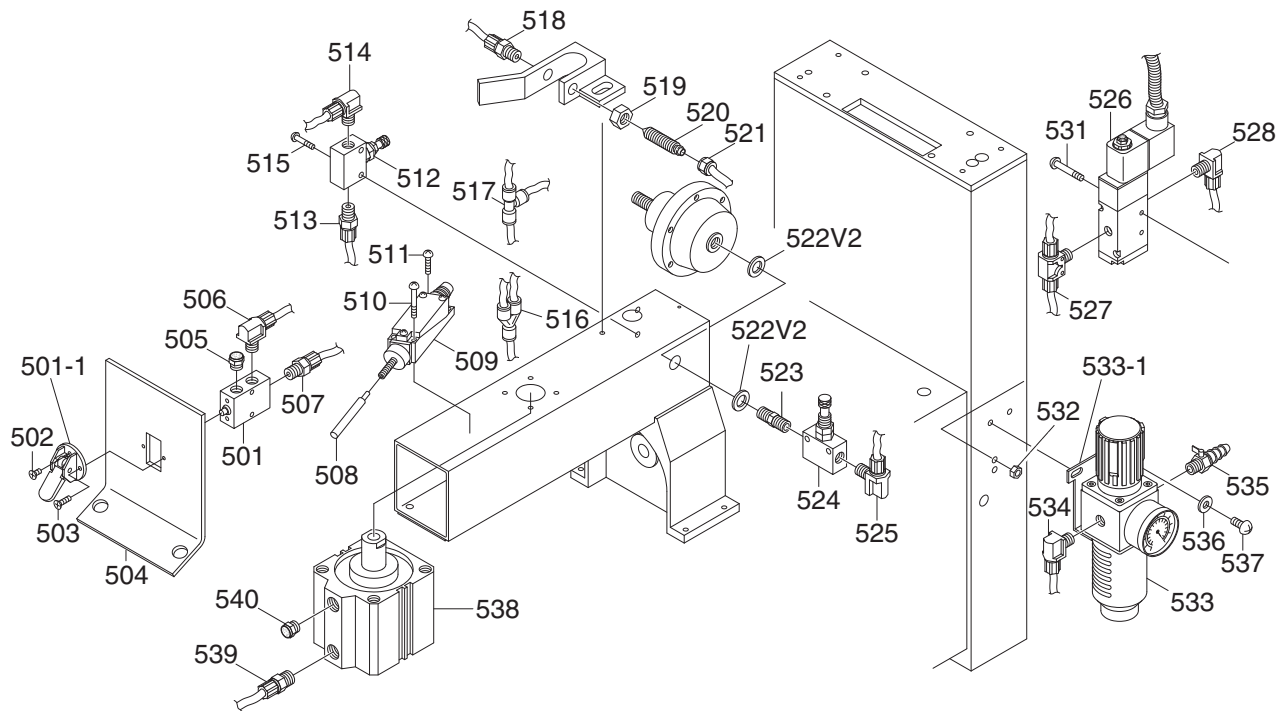
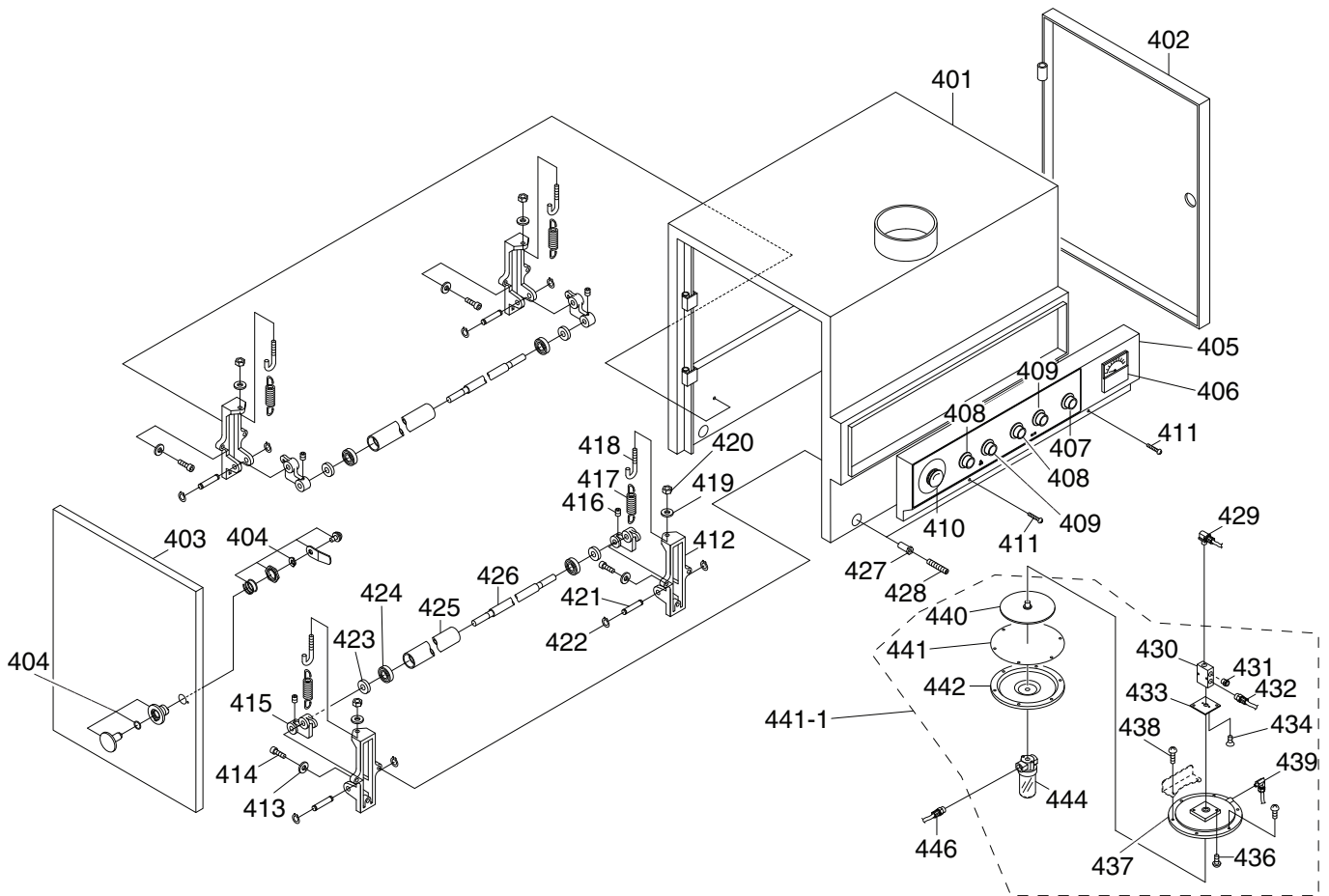

Sanding Cabinet & Air System Parts List

REF	PART #	DESCRIPTION
401	P9983401	MACHINE FRAME
402	P9983402	ACCESS DOOR RH
403	P9983403	ACCESS DOOR LH
404	P9983404	DOOR LOCK ASSEMBLY
405	P9983405	OPERATING PANEL
406	P9983406	LOAD METER
407	P9983407	POWER INDICATOR
408	P9983408	START BUTTON 250V 10A
409	P9983409	STOP BUTTON
410	P9983410	E-STOP BUTTON
411	PS47M	PHLP HD SCR M6-1 X 25
412	P9983412	PRESSURE ROLLER FRAME
413	PLW03M	LOCK WASHER 6MM
414	PCAP06M	CAP SCREW M6-1 X 25
415	P9983415	TILTING ARM
416	PSS26M	SET SCREW M5-.8 X 6
417	P9983417	EXTENSION SPRING D17.3 X 70
418	P9983418	SPRING HOOK
419	PW01M	FLAT WASHER 8MM
420	PN03M	HEX NUT M8-1.25
421	P9983421	CAPTIVE PIN
422	PR01M	EXT RETAINING RING 10MM
423	P9983423	BEARING COVER
424	P6001ZZ	BALL BEARING 6001ZZ
425	P9983425	PRESSURE ROLLER
426	P9983426	PRESSURE ROLLER SHAFT
427	P9983427	MACHINE FRAME HEX NUT M8-1.25
428	PSS42M	SET SCREW M8-1.25 X 50
429	P9983514	PLASTIC CONNECTOR L6-1/8"
430	P9983430	SWITCHING VALVE 1/8"
431	P9983431	SILENCER 1/8"
432	P9983513	PLASTIC CONNECTOR C6-1/8"
433	P9983433	LINING
434	PS49M	PHLP HD SCR M3-.5 X 5
436	PS02M	PHLP HD SCR M4-.7 X 12
437	P9983437	TOP ALUMINUM COVER
438	PS06M	PHLP HD SCR M5-.8 X 20
439	P9983439	BRASS HOSE CONNECTOR M6 X 1/4"
440	P9983440	PLATE
441	P9983441	DIAPHRAGM
441-1	P9983441-1	COMPLETE DIAPHRAGM ASSY
442	P9983442	BOTTOM ALUMINUM COVER

REF	PART #	DESCRIPTION
444	P9983444	CUP 1/4"
446	P9983518	PLASTIC CONNECTOR C6-1/8"
501	P9983501	SWITCHING VALVE
501-1	P9983501-1	SWITCHING VALVE SWITCH
502	PS12M	PHLP HD SCR M3-.5 X 6
503	PS12M	PHLP HD SCR M3-.5 X 6
504	P9983504	LIMIT SWITCH PANEL
505	P9983505	SILENCER 1/8"
506	P9983514	PLASTIC CONNECTOR L6-1/8"
507	P9983513	PLASTIC CONNECTOR C6-1/8"
508	P9962Z0002	LIMIT SWITCH CERAMIC TIP
509	P9962Z6115-1	LIMIT SWITCH W/PLASTIC TIP
510	PS50M	PHLP HD SCR M3-.5 X 12
511	PS50M	PHLP HD SCR M3-.5 X 12
512	P9983524	AIR VALVE 1/8"
513	P9983513	PLASTIC CONNECTOR C6-1/8"
514	P9983514	PLASTIC CONNECTOR L6-1/8"
515	PS52M	PHLP HD SCR M4-.7 X 20
516	P9983516	PLASTIC CONNECTOR 6Y
517	P9983517	PLASTIC CONNECTOR 6T
518	P9983518	PLASTIC CONNECTOR C6-1/8"
519	PN11	HEX NUT 3/8-24
520	P9983520	AIR EYELET OUT 3/8"
521	P9983521	BRASS NUT 3/8-24
522V2	POR0010	O-RING 10 X 2
523	P9983523	BRASS CONNECTOR 1/8" X 3/8"
524	P9983524	AIR VALVE 1/8"
525	P9983514	PLASTIC CONNECTOR L6-1/8"
526	P9983526	SOLENOID VALVE 1/8" X 220V
527	P9983527	PLASTIC CONNECTOR B6-1/8"
528	P9983514	PLASTIC CONNECTOR L6-1/8"
531	PS25M	PHLP HD SCR M4-.7 X 35
532	PN04M	HEX NUT M4-.7
533	P9983533	PRESSURE GAUGE K-1000FR2
533-1	P9983533-1	PRESSURE GAUGE BRACKET
534	P9983534	PLASTIC CONNECTOR L6-1/4"
535	P9983535	AIR COCK 1/4" X 5/16"
536	PW03M	FLAT WASHER 6MM
537	PS14M	PHLP HD SCR M6-1 X 12
538	P9983538	TENSION CYLINDER 63 X 40ST
539	P9983539	PLASTIC CONNECTOR C6-1/4"
540	P9983538	TENSION CYLINDER 63 X 40ST



Electrical Cabinet

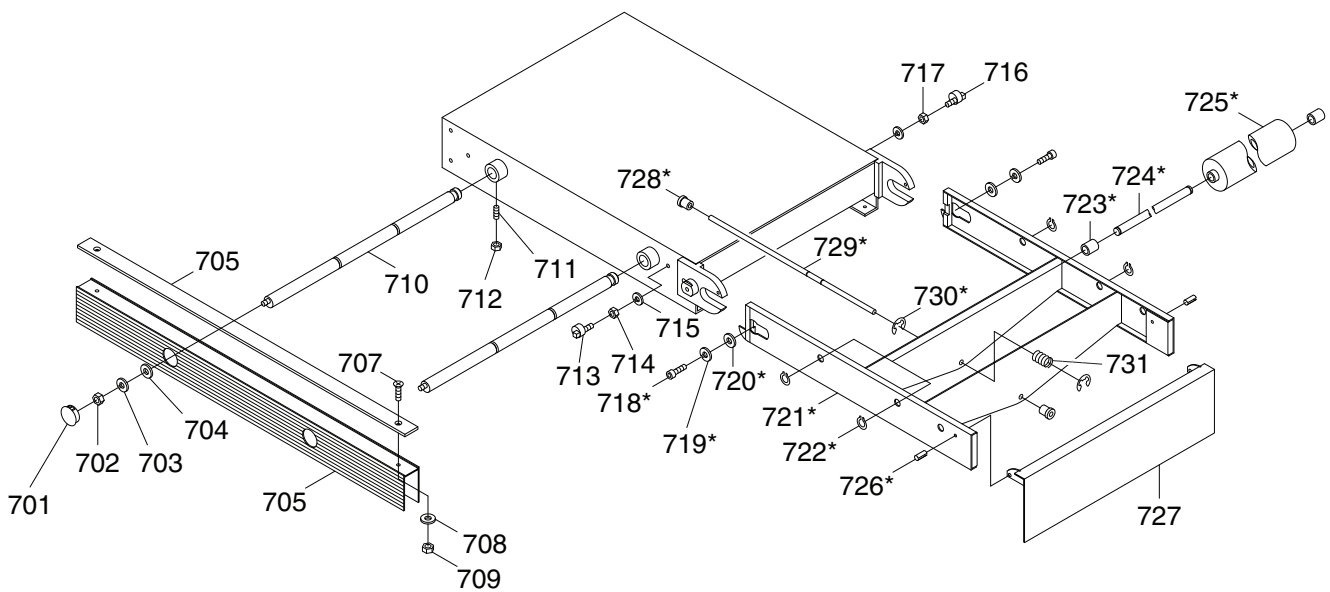
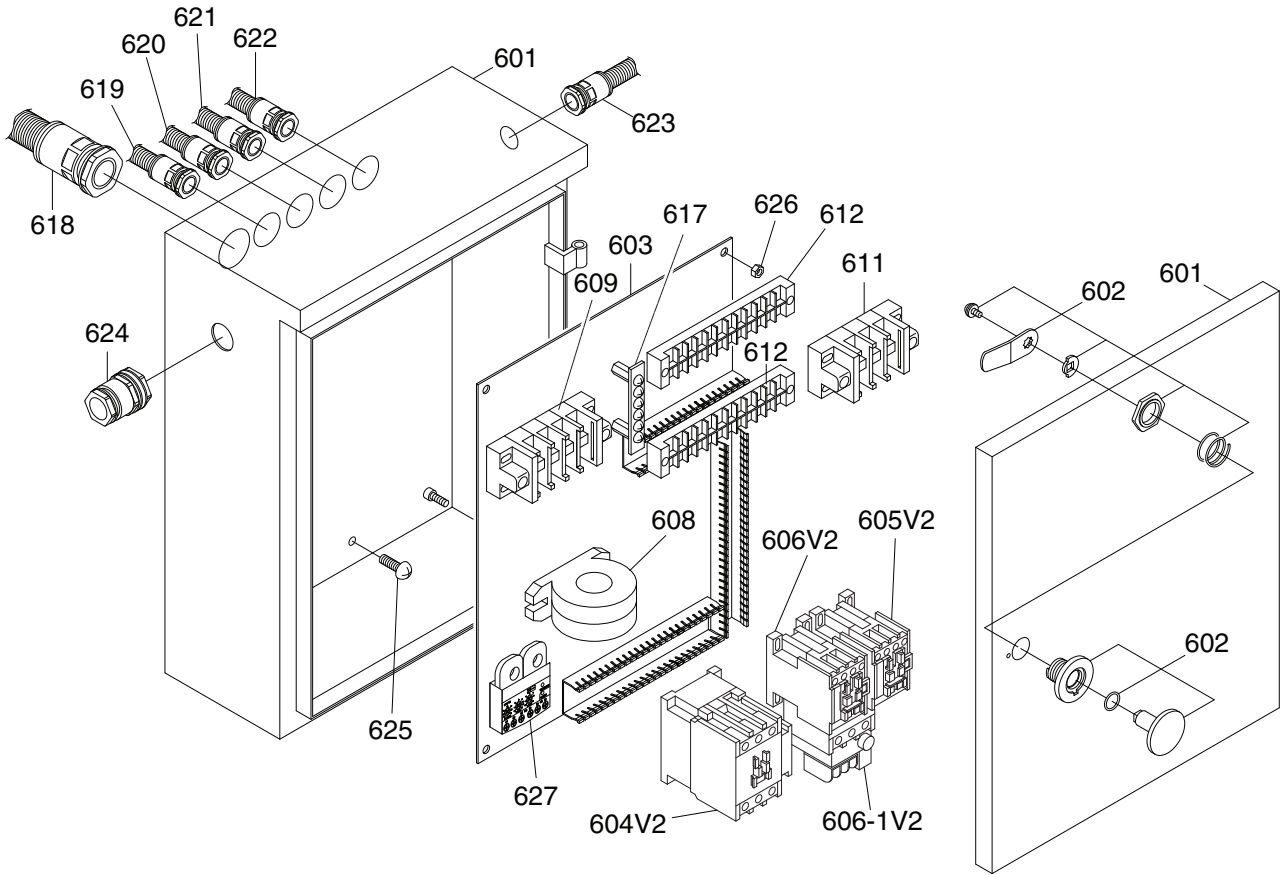

* Optional Parts



REF	PART #	DESCRIPTION
601	P9983601	CONTROL BOX
602	P9983602	DOOR LOCK ASSEMBLY
603	P9983603	ELECTRICAL MOUNTING PLATE
604V2	P9983604V2	CONTACTOR TECO CN-27 220V V2.10.08
605V2	P9983605V2	CONTACTOR TECO CU-11 220V V2.10.08
606-1V2	P9983606-1V2	OL RELAY TECO RHU-10K 1.4-2A V2.08.09
606V2	P9983606V2	CONTACTOR TECO CU-11 220V V2.10.08
608	P9983608	CURRENT TRANSFORMER
609	P9983609	TERMINAL BOARD 6P
611	P9983611	TERMINAL BOARD 5P
612	P9983612	TERMINAL BOARD 12P
617	P9983617	GROUND WIRE PANEL
618	P9983618	STRAIN RELIEF 1"
619	P9983619	STRAIN RELIEF 3/8"
620	P9983620	STRAIN RELIEF 5/16"
621	P9983621	STRAIN RELIEF 3/8"
622	P9983622	STRAIN RELIEF 3/8"
623	P9983623	STRAIN RELIEF 3/8"
624	P9983624	STRAIN RELIEF
625	PS14M	PHLP HD SCR M6-1 X 12
626	PN01M	HEX NUT M6-1
627	P9983627	OL RELAY TELE TESYS-LT47 5-60A
701	P9983701	PLASTIC COVER
702	PN03M	HEX NUT M8-1.25
703	PLW04M	LOCK WASHER 8MM
704	PW01M	FLAT WASHER 8MM

REF	PART #	DESCRIPTION
705	P9983705	TABLE SUPPORT W/SUPPORT LINING
707	PS11M	PHLP HD SCR M6-1 X 16
708	PW03M	FLAT WASHER 6MM
709	PN01M	HEX NUT M6-1
710	P9983710	RETRACTABLE ROD
711	PSS10M	SET SCREW M10-1.5 X 20
712	PN02M	HEX NUT M10-1.5
713	P9983713	ECCENTRIC SHAFT LH
714	PN27M	HEX NUT M10-1.5 LH
715	PLW06M	LOCK WASHER 10MM
716	P9983716	ECCENTRIC SHAFT RH
717	PN02M	HEX NUT M10-1.5
718	PCAP62M	CAP SCREW M10-1.5 X 12
719	PLW06M	LOCK WASHER 10MM
720	PW04M	FLAT WASHER 10MM
721	P9983721	INFEED TABLE FRAME
722	PR47M	EXT RETAINING RING 13MM
723	P9983723	ROLLER BUSHING
724	P9983724	ROLLER SHAFT
725	P9983725	CONVEYOR ROLLER
726	PRP28M	ROLL PIN 5 X 40
727	P9983727	EMERGENCY BRAKE PANEL
728	P9983728	KNOB
729	P9983729	BRAKE ROD
730	PR39M	EXT RETAINING RING 8MM
731	P9983731	COMPRESSION SPRING D8.5 X 40MM



Machine Labels

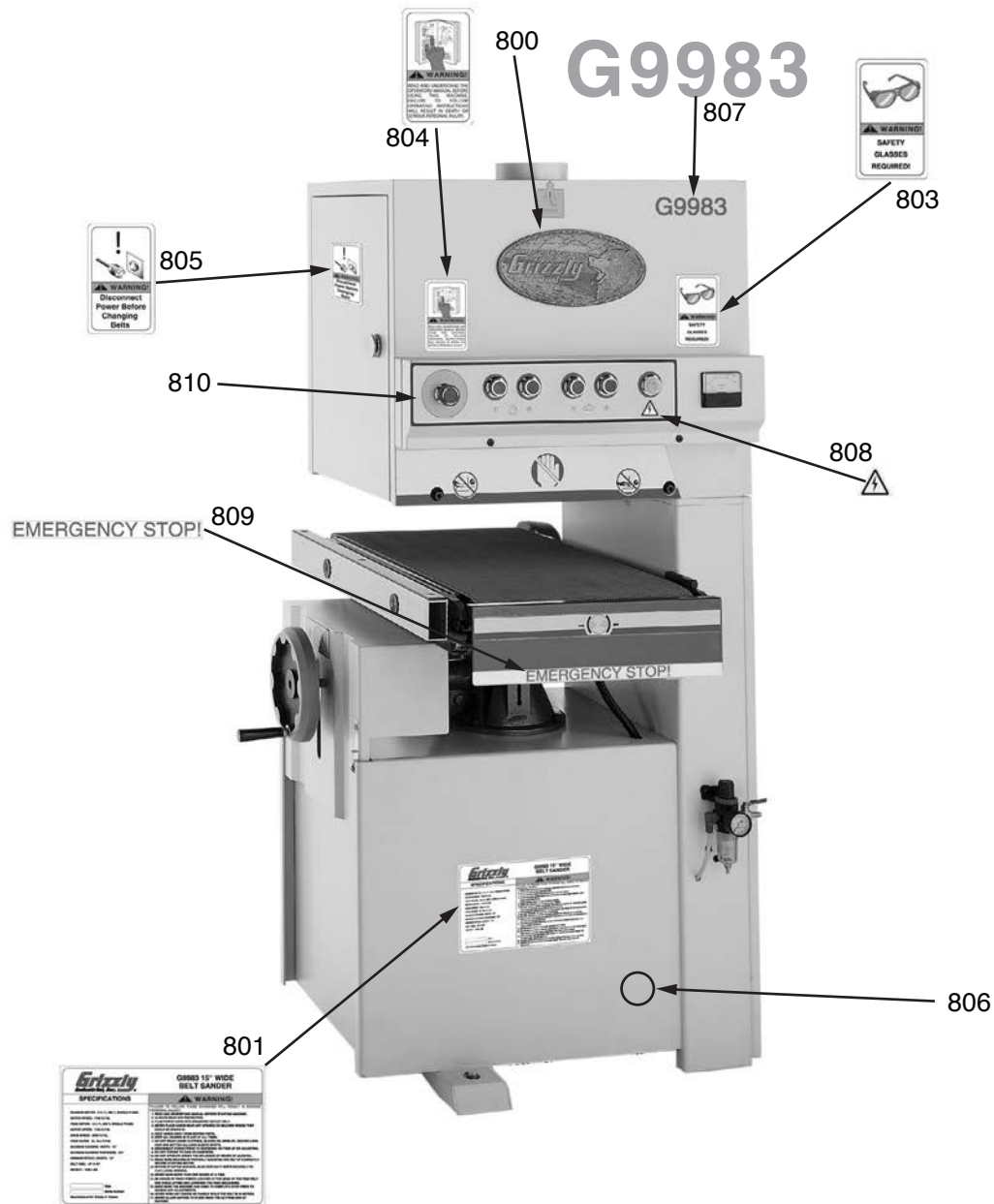

REF PART #	DESCRIPTION
800	G8589 GRIZZLY NAMEPLATE-LARGE
801	P9983801 MACHINE ID LABEL
803	PLABEL-11 SAFETY GLASSES 2W X 3.3H V1
804	PLABEL-12A READ MANUAL 2W X 3.3H V2.07.05
805	PLABEL-13 DISCONNECT SANDER 220V 2W X 3.3H

REF PART #	DESCRIPTION
806	PPAINT-11 GRIZZLY PUTTY TOUCH-UP PAINT
807	P9983807 MODEL NO LABEL
808	PLABEL-14 ELECTRICITY LABEL
809	P9983809 EMERGENCY STOP LABEL
810	P9983810 CONTROL PANEL LABEL

WARNING

Safety labels help reduce the risk of serious injury caused by machine hazards. If any label comes off or becomes unreadable, the owner of this machine **MUST** replace it in the original location before resuming operations. For replacements, contact (800) 523-4777 or www.grizzly.com.





WARRANTY CARD

Name _____
 Street _____
 City _____ State _____ Zip _____
 Phone # _____ Email _____
 Model # _____ Order # _____ Serial # _____

The following information is given on a voluntary basis. It will be used for marketing purposes to help us develop better products and services. **Of course, all information is strictly confidential.**

- How did you learn about us?

<input type="checkbox"/> Advertisement	<input type="checkbox"/> Friend	<input type="checkbox"/> Catalog
<input type="checkbox"/> Card Deck	<input type="checkbox"/> Website	<input type="checkbox"/> Other:
- Which of the following magazines do you subscribe to?

<input type="checkbox"/> Cabinetmaker & FDM	<input type="checkbox"/> Popular Science	<input type="checkbox"/> Wooden Boat
<input type="checkbox"/> Family Handyman	<input type="checkbox"/> Popular Woodworking	<input type="checkbox"/> Woodshop News
<input type="checkbox"/> Hand Loader	<input type="checkbox"/> Precision Shooter	<input type="checkbox"/> Woodsmith
<input type="checkbox"/> Handy	<input type="checkbox"/> Projects in Metal	<input type="checkbox"/> Woodwork
<input type="checkbox"/> Home Shop Machinist	<input type="checkbox"/> RC Modeler	<input type="checkbox"/> Woodworker West
<input type="checkbox"/> Journal of Light Cont.	<input type="checkbox"/> Rifle	<input type="checkbox"/> Woodworker's Journal
<input type="checkbox"/> Live Steam	<input type="checkbox"/> Shop Notes	<input type="checkbox"/> Other:
<input type="checkbox"/> Model Airplane News	<input type="checkbox"/> Shotgun News	
<input type="checkbox"/> Old House Journal	<input type="checkbox"/> Today's Homeowner	
<input type="checkbox"/> Popular Mechanics	<input type="checkbox"/> Wood	
- What is your annual household income?

<input type="checkbox"/> \$20,000-\$29,000	<input type="checkbox"/> \$30,000-\$39,000	<input type="checkbox"/> \$40,000-\$49,000
<input type="checkbox"/> \$50,000-\$59,000	<input type="checkbox"/> \$60,000-\$69,000	<input type="checkbox"/> \$70,000+
- What is your age group?

<input type="checkbox"/> 20-29	<input type="checkbox"/> 30-39	<input type="checkbox"/> 40-49
<input type="checkbox"/> 50-59	<input type="checkbox"/> 60-69	<input type="checkbox"/> 70+
- How long have you been a woodworker/metalworker?

<input type="checkbox"/> 0-2 Years	<input type="checkbox"/> 2-8 Years	<input type="checkbox"/> 8-20 Years	<input type="checkbox"/> 20+ Years
------------------------------------	------------------------------------	-------------------------------------	------------------------------------
- How many of your machines or tools are Grizzly?

<input type="checkbox"/> 0-2	<input type="checkbox"/> 3-5	<input type="checkbox"/> 6-9	<input type="checkbox"/> 10+
------------------------------	------------------------------	------------------------------	------------------------------
- Do you think your machine represents a good value? Yes No
- Would you recommend Grizzly Industrial to a friend? Yes No
- Would you allow us to use your name as a reference for Grizzly customers in your area?
Note: We never use names more than 3 times. Yes No

10. Comments: _____

CUT ALONG DOTTED LINE

FOLD ALONG DOTTED LINE



Place
Stamp
Here



GRIZZLY INDUSTRIAL, INC.
P.O. BOX 2069
BELLINGHAM, WA 98227-2069



FOLD ALONG DOTTED LINE

Send a Grizzly Catalog to a friend:

Name _____
Street _____
City _____ State _____ Zip _____

TAPE ALONG EDGES--PLEASE DO NOT STAPLE

WARRANTY & RETURNS

Grizzly Industrial, Inc. warrants every product it sells for a period of **1 year** to the original purchaser from the date of purchase. This warranty does not apply to defects due directly or indirectly to misuse, abuse, negligence, accidents, repairs or alterations or lack of maintenance. This is Grizzly's sole written warranty and any and all warranties that may be implied by law, including any merchantability or fitness, for any particular purpose, are hereby limited to the duration of this written warranty. We do not warrant or represent that the merchandise complies with the provisions of any law or acts unless the manufacturer so warrants. In no event shall Grizzly's liability under this warranty exceed the purchase price paid for the product and any legal actions brought against Grizzly shall be tried in the State of Washington, County of Whatcom.

We shall in no event be liable for death, injuries to persons or property or for incidental, contingent, special, or consequential damages arising from the use of our products.

To take advantage of this warranty, contact us by mail or phone and give us all the details. We will then issue you a "Return Number," which must be clearly posted on the outside as well as the inside of the carton. We will not accept any item back without this number. Proof of purchase must accompany the merchandise.

The manufacturers reserve the right to change specifications at any time because they constantly strive to achieve better quality equipment. We make every effort to ensure that our products meet high quality and durability standards and we hope you never need to use this warranty.

Please feel free to write or call us if you have any questions about the machine or the manual.

Thank you again for your business and continued support. We hope to serve you again soon.

grizzly.com[®]

TOOL WEBSITE

Buy Direct and Save with Grizzly[®] – Trusted, Proven and a Great Value!
~Since 1983~

*Visit Our Website Today For
Current Specials!*

**ORDER
24 HOURS A DAY!
1-800-523-4777**

