

# READ THIS FIRST



**Model G9742**

**\*\*\*IMPORTANT UPDATE\*\*\***

**For Machines Mfd. Since 04/26  
and Owner's Manual Revised 07/18**

*For questions or help with this product contact Tech Support at (570) 546-9663 or [techsupport@grizzly.com](mailto:techsupport@grizzly.com)*

The following change was recently made since the owner's manual was printed:

- Specifications changed.
- Parts changed.
- **CIRCUIT REQUIREMENTS, Inventory and Cabinet, Wheels & Feet** sections changed.
- **Cutting Angles and Using Vise** sections added.
- Electrical component photos and wiring diagram changed.
- Labels changed.

Aside from this information, all other content in the owner's manual applies and **MUST** be read and understood for your own safety. **IMPORTANT: Keep this update with the owner's manual for future reference.**

*For questions or help, contact our Tech Support at (570) 546-9663 or [techsupport@grizzly.com](mailto:techsupport@grizzly.com).*

## Revised Specifications

### Electrical:

Power Requirement .....	115V or 230V, Single-Phase, 60 Hz
Prewired Voltage .....	115V
Full-Load Current Rating.....	9A at 115V, 4.5A at 230V
Minimum Circuit Size .....	15A at 115V, 15A at 230V
Included Plug Size .....	5-15 for 115V
Recommended Plug Size .....	6-15 for 230V

### Motors:

#### Main

Amps .....	9A/4.5A
Speed .....	1720 RPM

### Other Specifications:

Country of Origin .....	Taiwan
-------------------------	--------

COPYRIGHT © MARCH, 2026 BY GRIZZLY INDUSTRIAL, INC.  
**WARNING: NO PORTION OF THIS MANUAL MAY BE REPRODUCED IN ANY SHAPE  
OR FORM WITHOUT THE WRITTEN APPROVAL OF GRIZZLY INDUSTRIAL, INC.**  
#CS23713 PRINTED IN TAIWAN

## Revised Parts

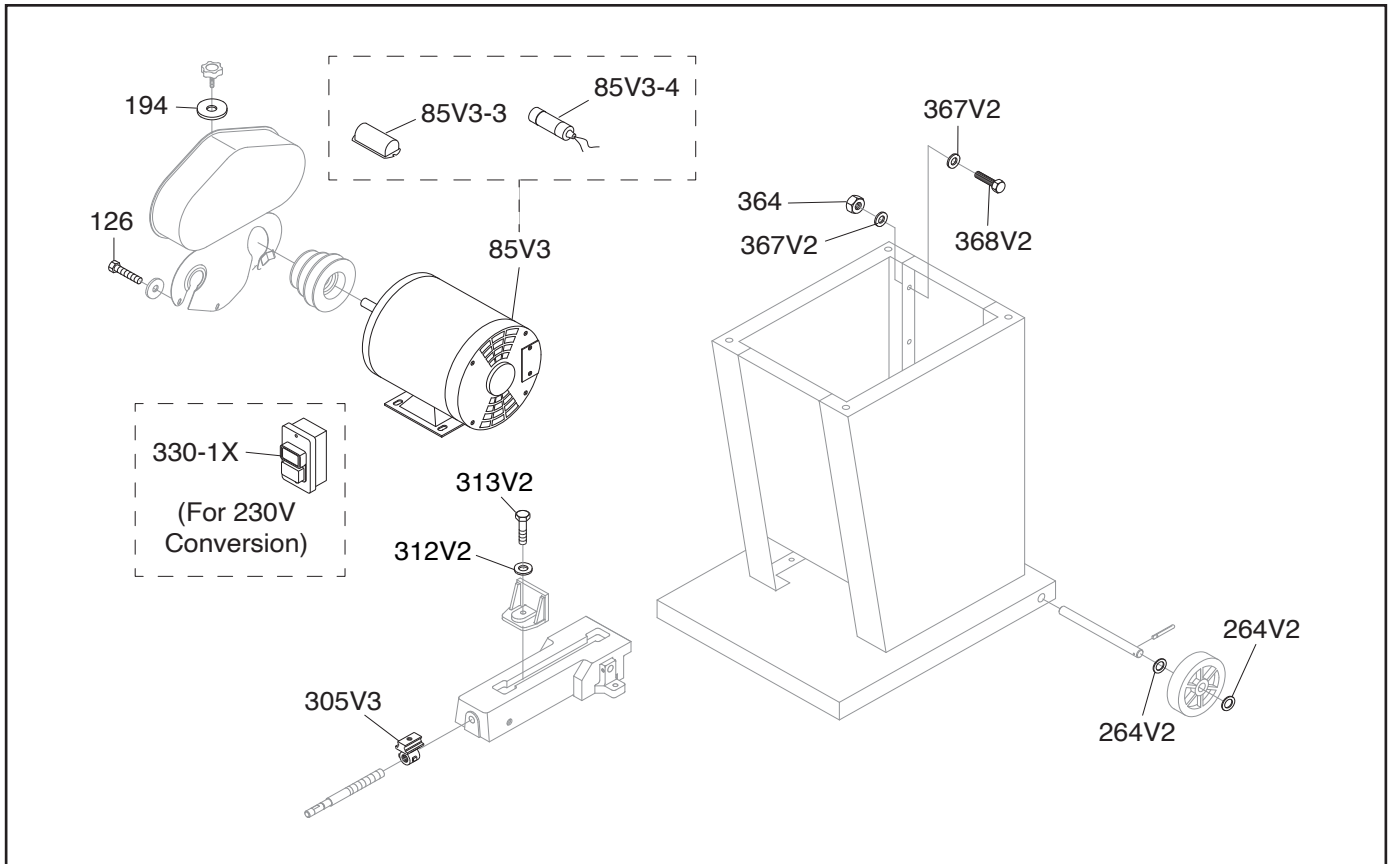

REF	PART #	DESCRIPTION
85V3	P9742085V3	MOTOR 1/2HP 115V/230V 1-PH V3.01.25
85V3-3	P9742085V3-3	CAPACITOR COVER
85V3-4	P9742085V3-4	S CAPACITOR 200M 125V
126	P9742126	HEX BOLT 1/4-20 X 1/2
194	P9742194	FENDER WASHER 1/4
264V2	P9742264V2	FLAT WASHER 5/8 V2.04.26
305V3	P9742305V3	BRACKET W/NUT V3.04.26

REF	PART #	DESCRIPTION
312V2	P9742312V2	FLAT WASHER 10 X 27 X 3MM V2.04.26
313V2	P9742313V2	HEX BOLT 3/8-16 X 1-1/4 V2.04.26
330-1X	P9742330-1X	TWO-BUTTON SWITCH KEDU KJD12/250V
364	P9742364	HEX NUT M8-1.25
367V2	P9742367V2	FLAT WASHER 8MM V2.05.14
368V2	P9742368V2	HEX BOLT M8-1.25 X 16 V2.05.14



# SECTION 2: CIRCUIT REQUIREMENTS

## Availability

Before installing the machine, consider the availability and proximity of the required power supply circuit. If an existing circuit does not meet the requirements for this machine, a new circuit must be installed. To minimize the risk of electrocution, fire, or equipment damage, installation work and electrical wiring must be done by an electrician or qualified service personnel in accordance with all applicable codes and standards.

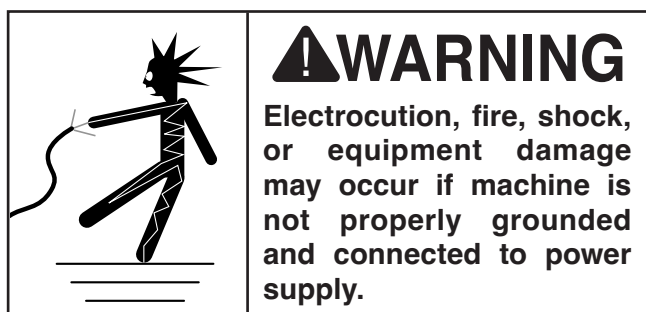

## Full-Load Current Rating

The full-load current rating is the amperage a machine draws at 100% of the rated output power. On machines with multiple motors, this is the amperage drawn by the largest motor or sum of all motors and electrical devices that might operate at one time during normal operations.

**Full-Load Current Rating at 115V ..... 9 Amps**

**Full-Load Current Rating at 230V .... 4.5 Amps**

The full-load current is not the maximum amount of amps that the machine will draw. If the machine is overloaded, it will draw additional amps beyond the full-load rating.

If the machine is overloaded for a sufficient length of time, damage, overheating, or fire may result—especially if connected to an undersized circuit. To reduce the risk of these hazards, avoid overloading the machine during operation and make sure it is connected to a power supply circuit that meets the specified circuit requirements.

## Circuit Information

A power supply circuit includes all electrical equipment between the breaker box or fuse panel in the building and the machine. The power supply circuit used for this machine must be sized to safely handle the full-load current drawn from the machine for an extended period of time. (If this machine is connected to a circuit protected by fuses, use a time delay fuse marked D.)

### ⚠ CAUTION

For your own safety and protection of property, consult an electrician if you are unsure about wiring practices or electrical codes in your area.

**Note:** *Circuit requirements in this manual apply to a dedicated circuit—where only one machine will be running on the circuit at a time. If machine will be connected to a shared circuit where multiple machines may be running at the same time, consult an electrician or qualified service personnel to ensure circuit is properly sized for safe operation.*

## Circuit Requirements for 115V

This machine is prewired to operate on a power supply circuit that has a verified ground and meets the following requirements:

**Nominal Voltage ..... 110V, 115V, 120V**  
**Cycle ..... 60 Hz**  
**Phase ..... Single-Phase**  
**Power Supply Circuit ..... 15 Amps**  
**Plug/Receptacle ..... NEMA 5-15**

## Circuit Requirements for 230V

This machine can be converted to operate on a power supply circuit that has a verified ground and meets the requirements listed below. (Refer to **Voltage Conversion** instructions for details.)

**Nominal Voltage ..... 208V, 220V, 230V, 240V**  
**Cycle ..... 60 Hz**  
**Phase ..... Single-Phase**  
**Power Supply Circuit ..... 15 Amps**  
**Plug/Receptacle ..... NEMA 6-15**



## Grounding Requirements

This machine **MUST** be grounded. In the event of certain malfunctions or breakdowns, grounding reduces the risk of electric shock by providing a path of least resistance for electric current.

**For 115V operation:** This machine is equipped with a power cord that has an equipment-grounding wire and a grounding plug (see following figure). The plug must only be inserted into a matching receptacle (outlet) that is properly installed and grounded in accordance with all local codes and ordinances.

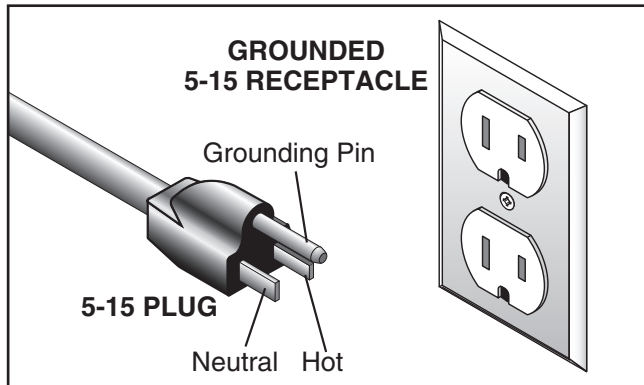

**Figure 1.** Typical 5-15 plug and receptacle.

**⚠ CAUTION**

**SHOCK HAZARD!**

**Two-prong outlets do not meet the grounding requirements for this machine. Do not modify or use an adapter on the plug provided—if it will not fit the outlet, have a qualified electrician install the proper outlet with a verified ground.**

**For 230V operation:** The power cord and plug specified under “Circuit Requirements for 230V” on the previous page have an equipment-grounding wire and a grounding prong. The plug must only be inserted into a matching receptacle (outlet) that is properly installed and grounded in accordance with all local codes and ordinances (see following figure).

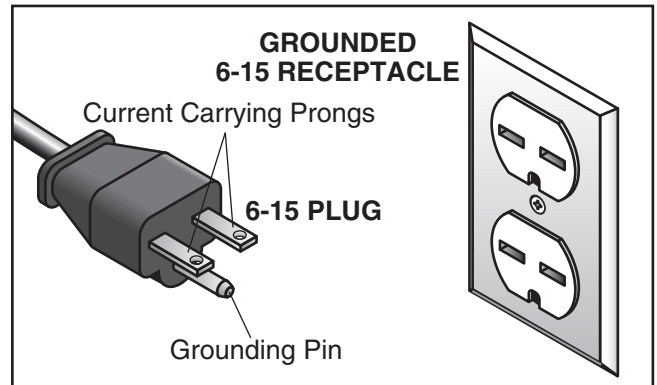

**Figure 2.** Typical 6-15 plug and receptacle.

Improper connection of the equipment-grounding wire can result in a risk of electric shock. The wire with green insulation (with or without yellow stripes) is the equipment-grounding wire. If repair or replacement of the power cord or plug is necessary, do not connect the equipment-grounding wire to a live (current carrying) terminal.

Check with a qualified electrician or service personnel if you do not understand these grounding requirements, or if you are in doubt about whether the machine is properly grounded. If you ever notice that a cord or plug is damaged or worn, disconnect it from power, and immediately replace it with a new one.

## Extension Cords

We do not recommend using an extension cord with this machine. If you must use an extension cord, only use it if absolutely necessary and only on a temporary basis.

Extension cords cause voltage drop, which can damage electrical components and shorten motor life. Voltage drop increases as the extension cord size gets longer and the gauge size gets smaller (higher gauge numbers indicate smaller sizes).

Any extension cord used with this machine must be in good condition and contain a ground wire and matching plug/receptacle. Additionally, it must meet the following size requirements:

**Minimum Gauge Size ..... 16 AWG**  
**Maximum Length (Shorter is Better).....50 ft.**



## Voltage Conversion

The voltage conversion **MUST** be performed by an electrician or qualified service personnel.

The voltage conversion procedure consists of rewiring the main motor, replacing the ON/OFF switch, and installing the correct plug. A wiring diagram is provided on **Page 15** of this update, for your reference.

**IMPORTANT:** If the diagram included on the motor conflicts with the one included on **Page 15** of this update, the motor may have changed since the manual was printed. Use the diagram included on the motor instead.

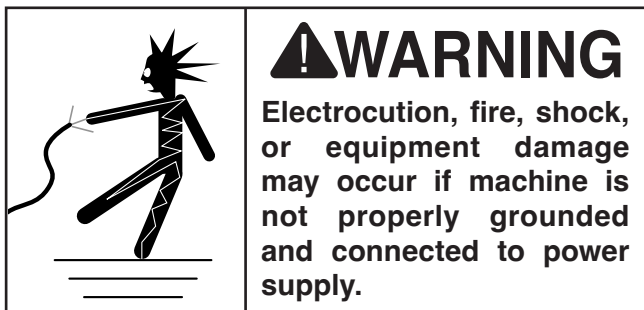
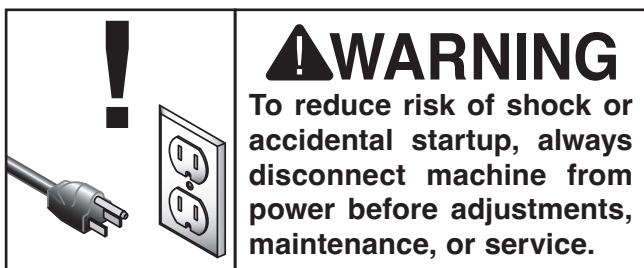

Items Needed	Qty
Phillips Head Screwdriver #2 .....	1
Wire Nut (18#AWG x 3) .....	1
Electrical Tape .....	As Needed
ON/OFF Switch 250V (#P9742330-1X) .....	1
Wire Stripper .....	1
Plug 6-15 .....	1

## To convert Model G9742 to 230V:

1. DISCONNECT MACHINE FROM POWER!
2. Cut off existing 5-15 plug.
3. Open motor junction box, then remove (2) wire nuts indicated in **Figure 3**.

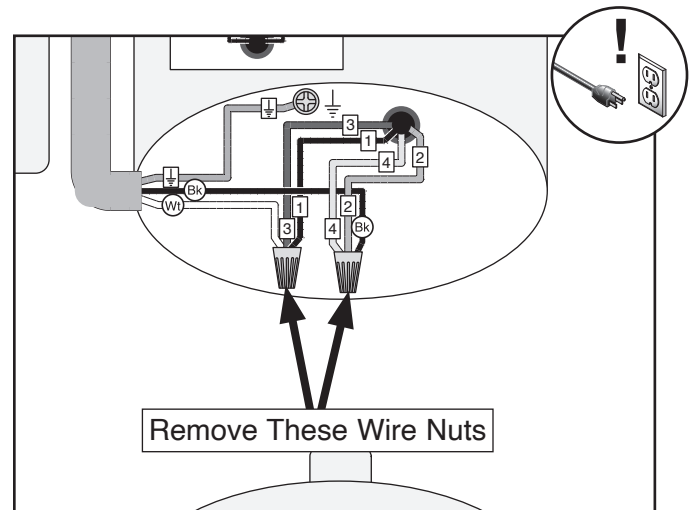

**Figure 3.** Motor wired for 115V.

4. Use wire nuts to connect wires as indicated in **Figure 4**. Twist wire nuts onto their respective wires and wrap them with electrical tape so they will not come loose during operation.

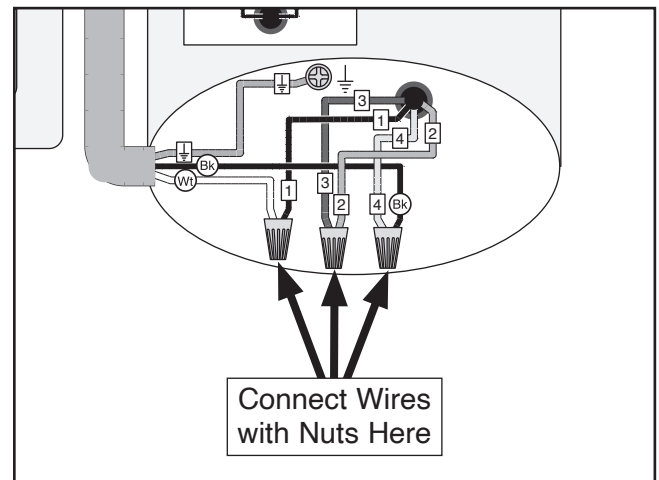

**Figure 4.** Motor wired for 230V.



5. Close and secure motor junction box.
6. Open switch box.
7. Disconnect wires from 120V ON/OFF switch and remove switch from switch box (see **Figure 5**).

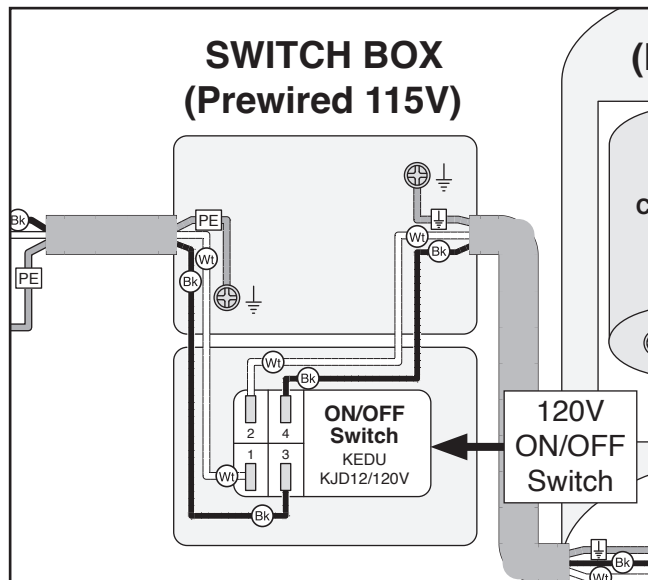

**Figure 5.** Location of 120V ON/OFF switch.

8. Install 250V ON/OFF switch and connect wires removed in **Step 7** (see **Figure 6**).

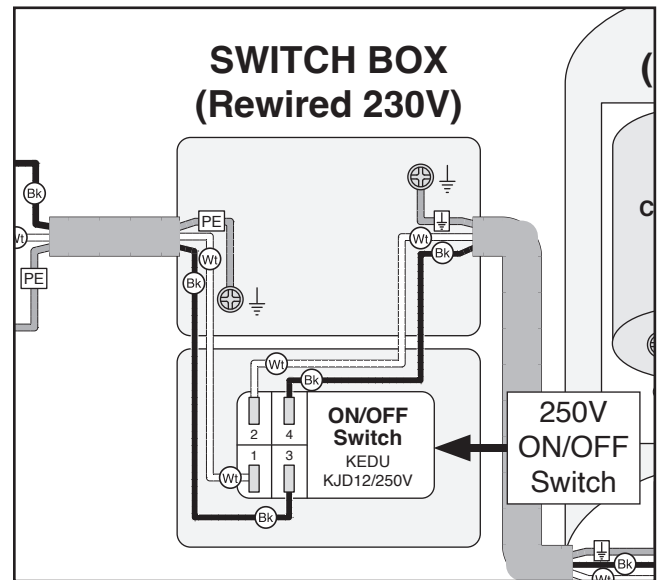

**Figure 6.** 250V ON/OFF switch wiring.

9. Close and secure switch box.
10. Install 6-15 plug on end of power cord, according to instructions and wiring diagrams provided by plug manufacturer.
  - If plug manufacturer did not include instructions, wiring of generic NEMA 6-15 plug is provided on **Page 15** of this update.



# Inventory

The following is a list of items shipped with your machine. Before beginning setup, lay these items out and inventory them.

If any non-proprietary parts are missing (e.g. a nut or a washer), we will gladly replace them; or for the sake of expediency, replacements can be obtained at your local hardware store.

## NOTICE

If you cannot find an item on this list, carefully check around/inside the machine and packaging materials. Often, these items get lost in packaging materials while unpacking or they are pre-installed at the factory.

Loose Items (Figure 7)	Qty
A. Base .....	1
B. Pulley Cover .....	1
C. Front Panel .....	1
D. Right Panel .....	1
E. Rear Panel .....	1
F. Left Panel .....	1
G. Stop Rod .....	1
H. Rubber Feet .....	4
I. V-Belt .....	1
J. Chip Tray .....	1
K. Wheels .....	2
L. Cast Iron Stop .....	1
M. Axle .....	1

Hardware (Figure 8)	Qty
N. Hex Bolts M8-1.25 x 30 (P9742362) .....	4
O. Flat Washers 5/8" (P9742264V2) .....	4
P. Cotter Pins 2.5 x 25mm (P9742333) .....	2
Q. Hex Bolts M8-1.25 x 16 (P9742368V2) .....	16
R. Hex Nuts M8-1.25 (P9742364) .....	16
S. Flat Washers 8mm (P9742367V2) .....	36
T. Hex Bolts 1/4"-20 x 1/2" (P9742126) .....	2
U. Fender Washers 1/4" (P9742194) .....	3
V. Knob Bolt 1/4"-20 x 5/8" (P9742196V2) .....	1

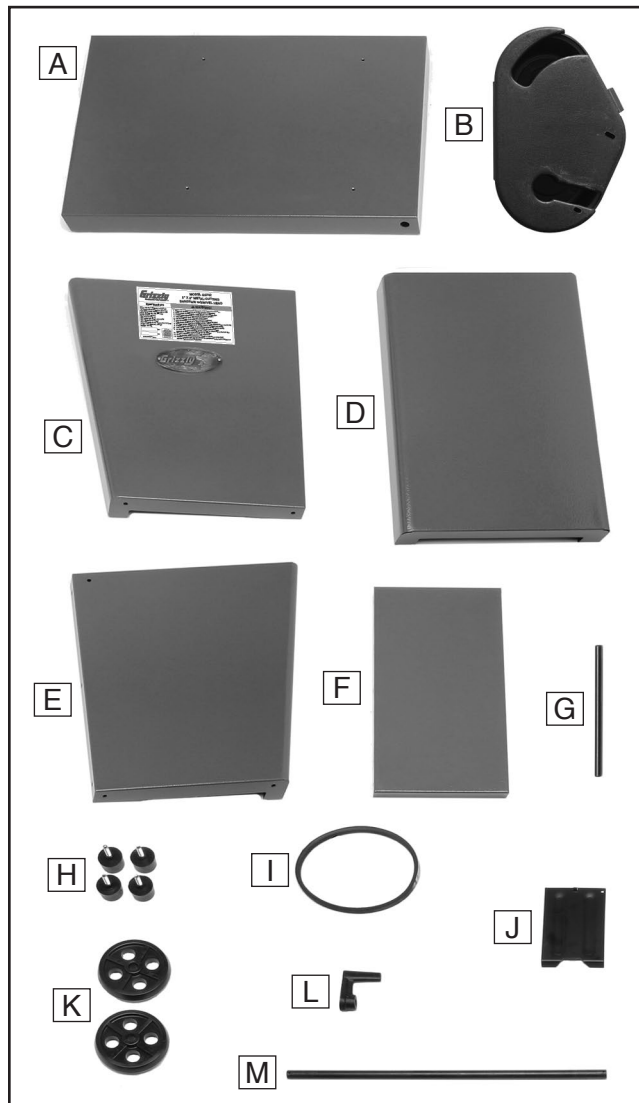

Figure 7. Loose item inventory.

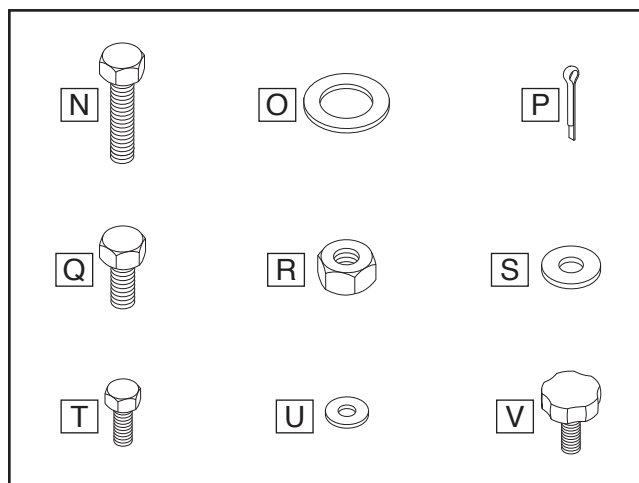

Figure 8. Hardware inventory (1 of each shown).



# Cabinet, Wheels & Feet

The bandsaw is shipped with rubber feet with posts and two wheels with an axle. Install the rubber feet if you do not need to move the bandsaw, or install the axle and wheels if you need to move the bandsaw regularly.

## To install cabinet, wheels, and feet:

1. Insert axle into end of base with axle holes (see **Figure 9**).
2. Slide  $\frac{5}{8}$ " flat washer and wheel on each end of axle, followed by another  $\frac{5}{8}$ " flat washer and cotter pin (see **Figure 9**).

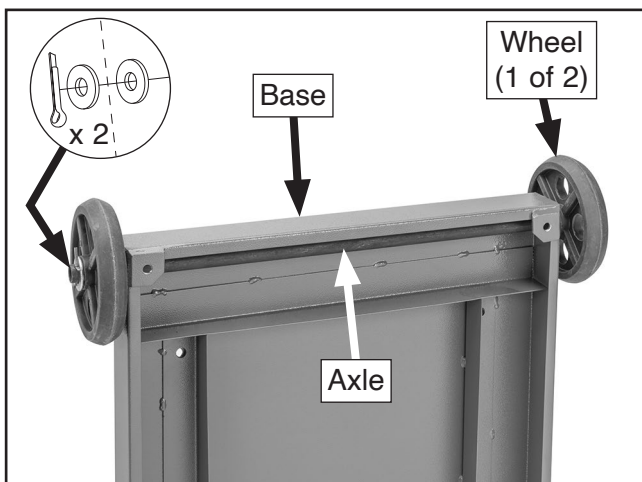

**Figure 9.** Axle and wheels installed on base.

3. Thread (4) rubber feet into base (see **Figure 10**).

**Note:** Do not install (2) feet on wheel side of base if you wish to use wheels to move machine.

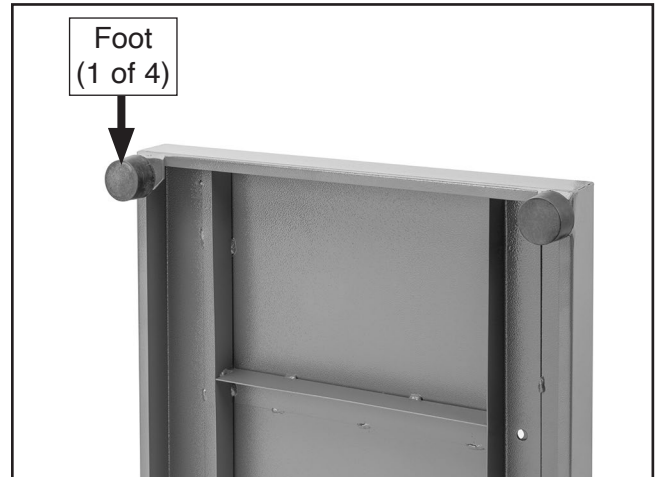

**Figure 10.** Threading feet into base.

4. Position base so feet are on floor, then adjust feet until base is level and stable.
5. Attach front and rear panels to base with (4) M8-1.25 x 16 hex bolts, (8) 8mm flat washers, and (4) M8-1.25 hex nuts (see **Figure 11**).

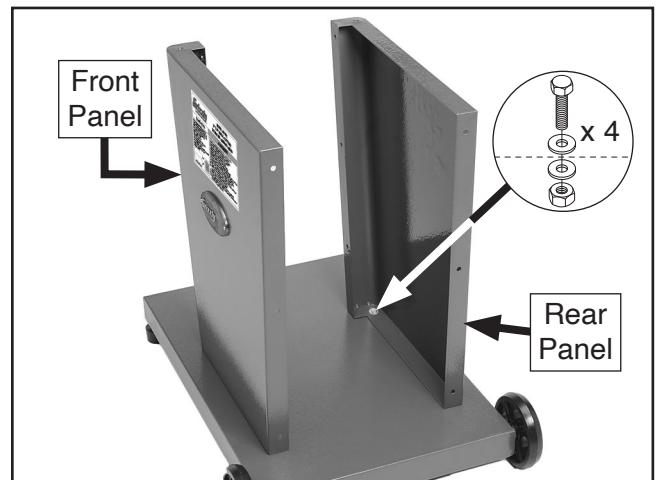

**Figure 11.** Front and rear panels attached to base.



6. Attach right and left panels to front and rear panels with (12) M8-1.25 x 16 hex bolts, (24) 8mm flat washers, and (12) M8-1.25 hex nuts (see **Figure 12**).

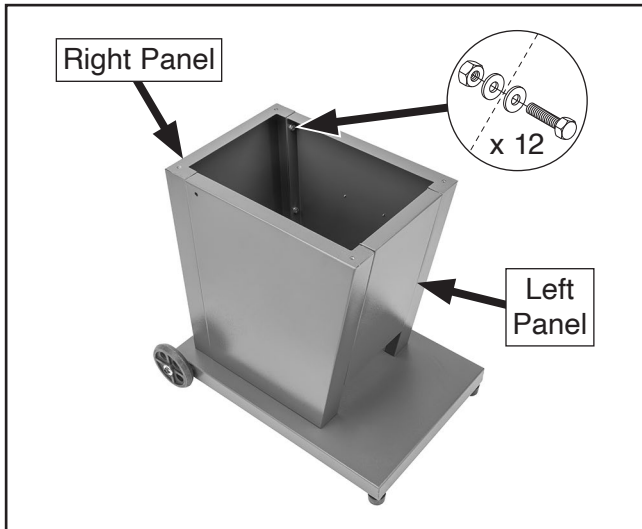

**Figure 12.** Right and left panels attached to front and rear panels.

## **! WARNING**

**Model G9742 is heavy! To avoid personal injury, get lifting help or use lifting equipment to lift this machine.**

7. With lifting help or a hoisting device, place bandsaw on top of cabinet.

8. Attach bandsaw to cabinet with (4) M8-1.25 x 30 hex bolts and 8mm flat washers (see **Figure 13**).

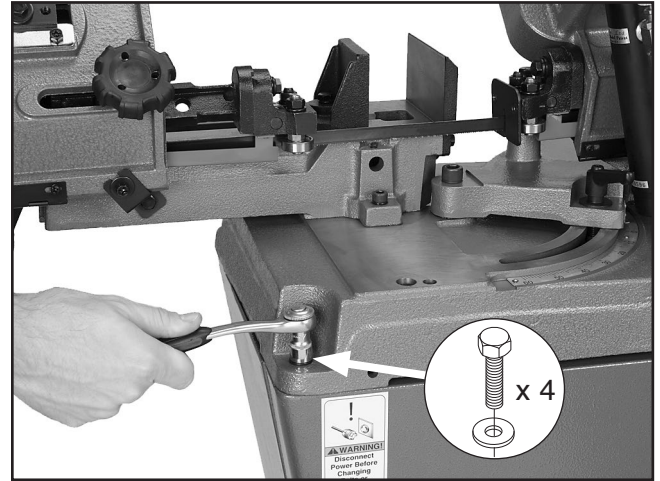

**Figure 13.** Example of attaching bandsaw to cabinet.

9. Install 1/4"-20 x 5/8" knob bolt and 1/4" fender washer on pulley cover (see **Figure 14**).

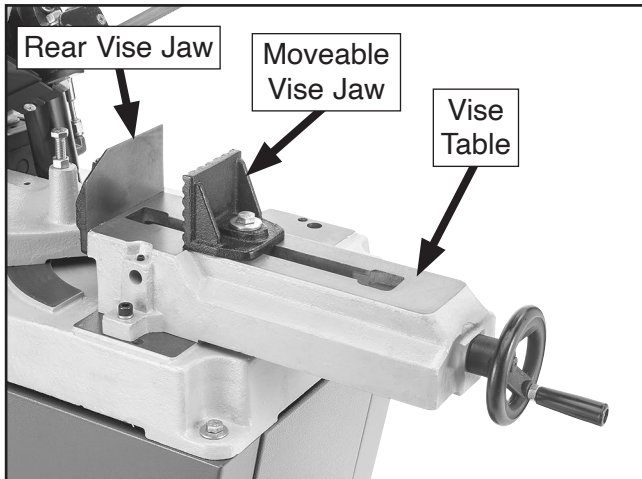

**Figure 14.** Knob bolt and washer installed.



# Cutting Angles

The headstock can be swiveled to cut angles from 0–45° to the right and 0–60° to the left for a total swing of 105°. The vise consists of the moveable vise jaw and the rear vise jaw mounted on the vise table (see **Figure 15**).



**Figure 15.** Vise jaws on vise table.

When making cuts to the right, the vise table should remain in the left-most position that it shipped in. If you need to make a cut to the left, you will have to move the vise table to the right side of the machine.

## Cutting to the Right

1. DISCONNECT MACHINE FROM POWER!
2. Raise headstock to maximum height and close valve lever on hydraulic cylinder to lock headstock in place.
3. Loosen headstock lock lever and adjust headstock angle to the right until indicator on angle scale shows desired angle between 0–45° (see **Figure 16**).

4. Tighten headstock lock lever (see **Figure 16**).

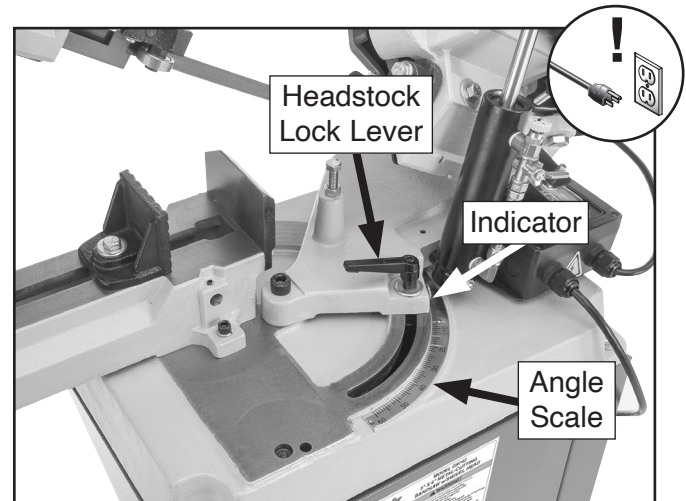

**Figure 16.** Headstock angle components.

5. Move headstock through its full range of motion to make sure blade will not contact vise during operation.

## Cutting to the Left

Tools Needed	Qty
Hex Wrenches 1/8", 6mm .....	1 Ea.

### To cut to the left:

1. DISCONNECT MACHINE FROM POWER!
2. Raise headstock to maximum height and close valve lever on hydraulic cylinder to lock headstock in place.
3. Loosen headstock lock lever and adjust headstock angle to the left until indicator on angle scale shows desired angle between 0–60° (see **Figure 16**).
4. Tighten headstock lock lever (see **Figure 16**).
5. Remove cast iron stop and chip tray, if installed.



6. Remove (2) vise table cap screws and lock washers (see **Figure 17**) to remove vise table from machine.

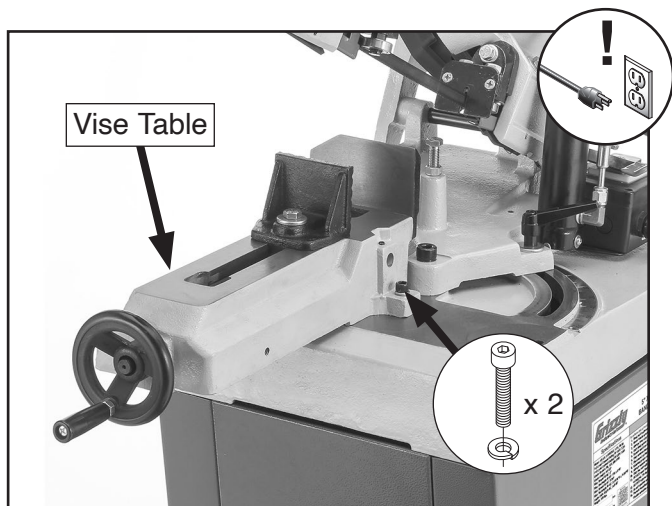

**Figure 17.** Vise table fasteners.

7. Move (2) bushings shown in **Figure 18** from left position holes to right position holes.

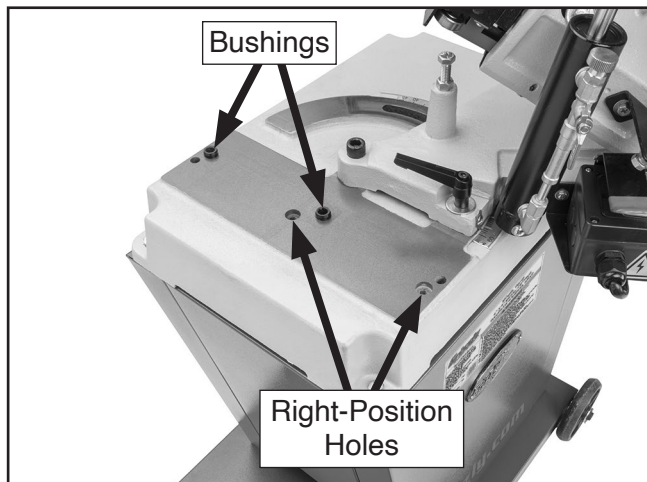

**Figure 18.** Vise table bushings and position holes.

8. Place vise table mounting holes over bushings, then attach to machine with fasteners removed in **Step 6** (see **Figure 19**).

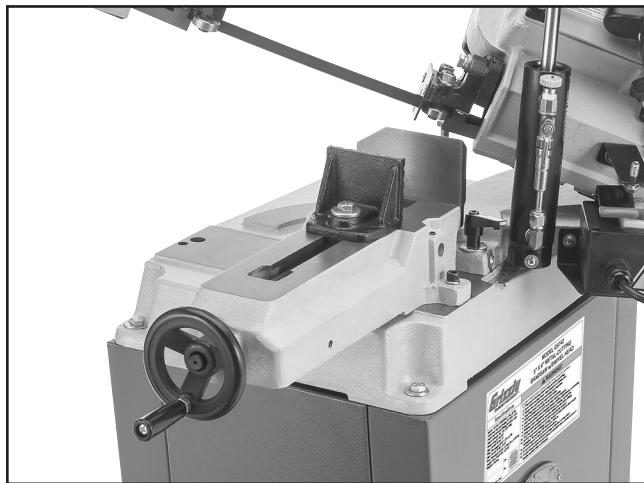

**Figure 19.** Vise table installed in right position.

9. Move headstock through its full range of motion to make sure blade will not contact vise during operation.
10. Install chip tray and cast iron stop, if needed for operation.



# Using Vise

The vise can hold material up to 6" wide and can be installed on either side of the blade for angled cuts. See **Cutting Angles** on **Page 10** for installing the vise table according to the headstock angle setting.

**Figure 20** shows the correct methods of holding different workpiece shapes. Never clamp more than one workpiece and always consider how a workpiece can be best supported.

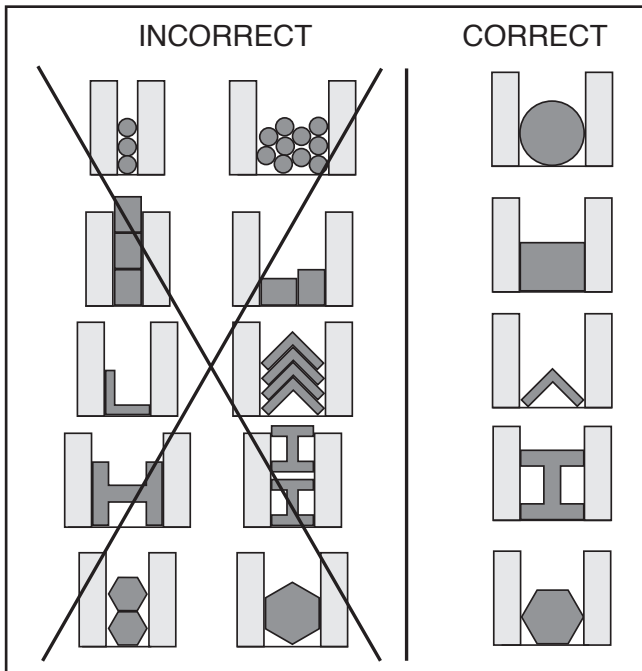

**Figure 20.** Workpiece holding options by shape.

## **! WARNING**

To avoid serious injury, always turn machine **OFF** and allow blade to come to complete stop before adjusting vise.

### To use vise:

1. DISCONNECT MACHINE FROM POWER!
2. Raise headstock to required height for workpiece.
3. Adjust headstock angle as desired (see **Cutting Angles** on **Page 10**).
4. Use vise clamp handwheel to open vise jaws enough to accept workpiece (see **Figure 21**).
5. Place workpiece against rear vise jaw (see **Figure 21**), then use vise clamp handwheel to move movable vise jaw until it contacts workpiece.

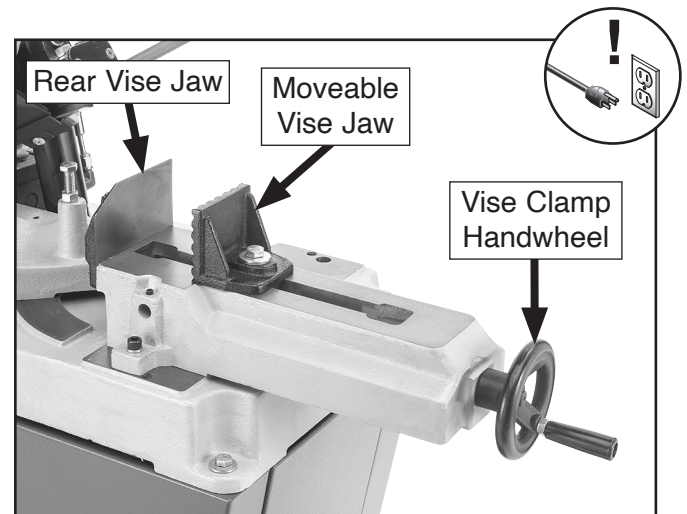

**Figure 21.** Vise controls and components.

6. Connect machine to power and cut workpiece.
7. Turn machine **OFF** and allow blade to come to complete stop.
8. Use vise clamp handwheel to open vise jaws and remove workpiece or advance it in jaws for additional cuts.



# WIRING

These pages are current at the time of printing. However, in the spirit of improvement, we may make changes to the electrical systems of future machines. Compare the manufacture date of your machine to the one stated in this manual, and study this section carefully.

If there are differences between your machine and what is shown in this section, call Technical Support at (570) 546-9663 for assistance BEFORE making any changes to the wiring on your machine. An updated wiring diagram may be available. **Note:** *Please gather the serial number and manufacture date of your machine before calling. This information can be found on the main machine label.*

## WARNING

### Wiring Safety Instructions

**SHOCK HAZARD.** Working on wiring that is connected to a power source is extremely dangerous. Touching electrified parts will result in personal injury including but not limited to severe burns, electrocution, or death. Disconnect the power from the machine before servicing electrical components!

**MODIFICATIONS.** Modifying the wiring beyond what is shown in the diagram may lead to unpredictable results, including serious injury or fire. This includes the installation of unapproved after-market parts.

**WIRE CONNECTIONS.** All connections must be tight to prevent wires from loosening during machine operation. Double-check all wires disconnected or connected during any wiring task to ensure tight connections.

**CIRCUIT REQUIREMENTS.** You MUST follow the requirements at the beginning of this manual when connecting your machine to a power source.

**WIRE/COMPONENT DAMAGE.** Damaged wires or components increase the risk of serious personal injury, fire, or machine damage. If you notice that any wires or components are damaged while performing a wiring task, replace those wires or components.

**MOTOR WIRING.** The motor wiring shown in these diagrams is current at the time of printing but may not match your machine. If you find this to be the case, use the wiring diagram inside the motor junction box.















**CAPACITORS/INVERTERS.** Some capacitors and power inverters store an electrical charge for up to 10 minutes after being disconnected from the power source. To reduce the risk of being shocked, wait at least this long before working on capacitors.

**EXPERIENCING DIFFICULTIES.** If you are experiencing difficulties understanding the information included in this section, contact our Technical Support at (570) 546-9663.

#### NOTICE

The photos and diagrams included in this section are best viewed in color. You can view these pages in color at [www.grizzly.com](http://www.grizzly.com).

#### COLOR KEY

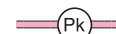
BLACK 	BLUE 	YELLOW 	LIGHT BLUE 
WHITE 	BROWN 	YELLOW GREEN 	BLUE WHITE 
GREEN 	GRAY 	PURPLE 	TURQUOISE 
RED 	ORANGE 	PINK 	





# G9742 Wiring Diagram

## 115V

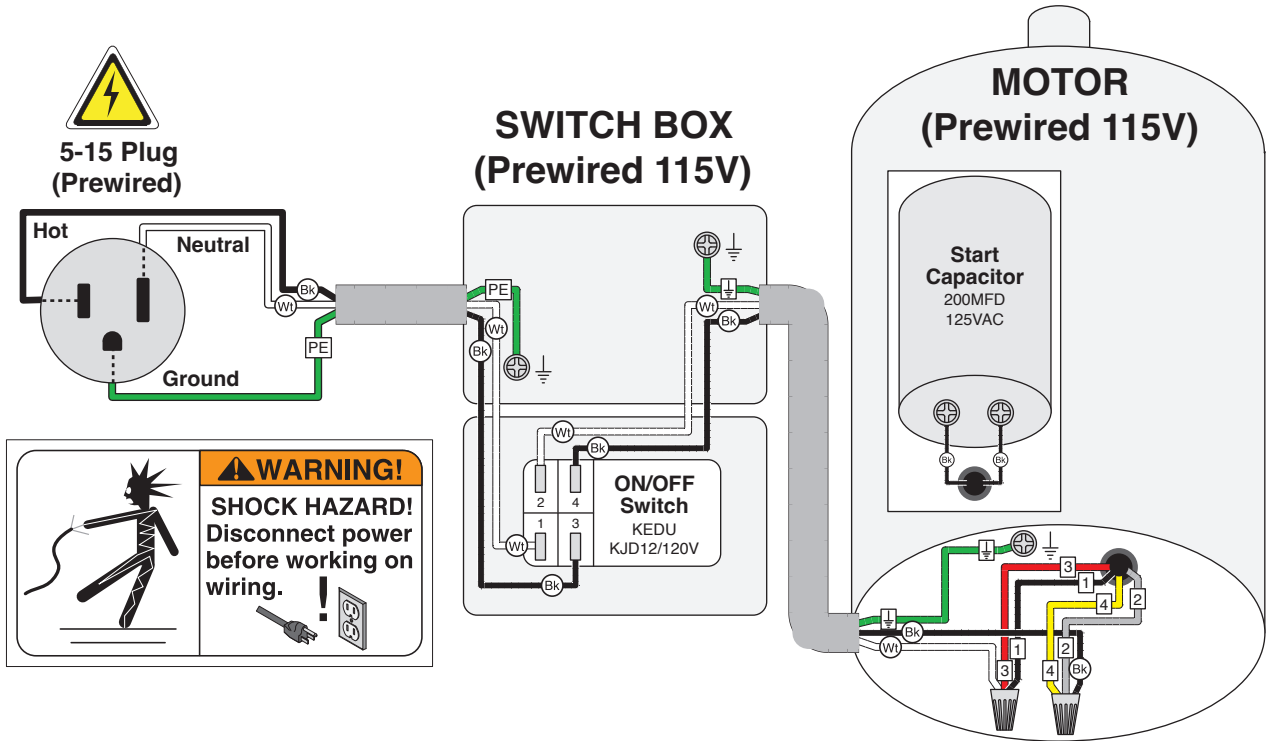

## 230V

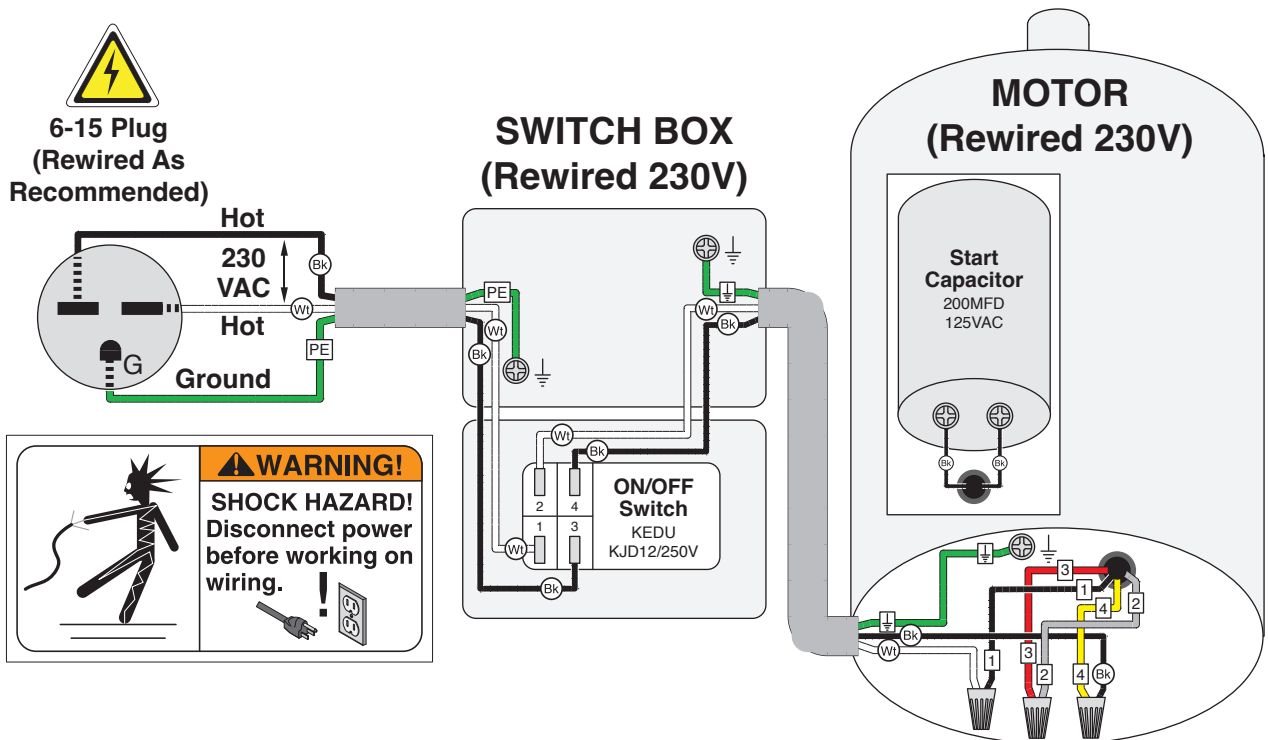

# Labels Parts Breakdown

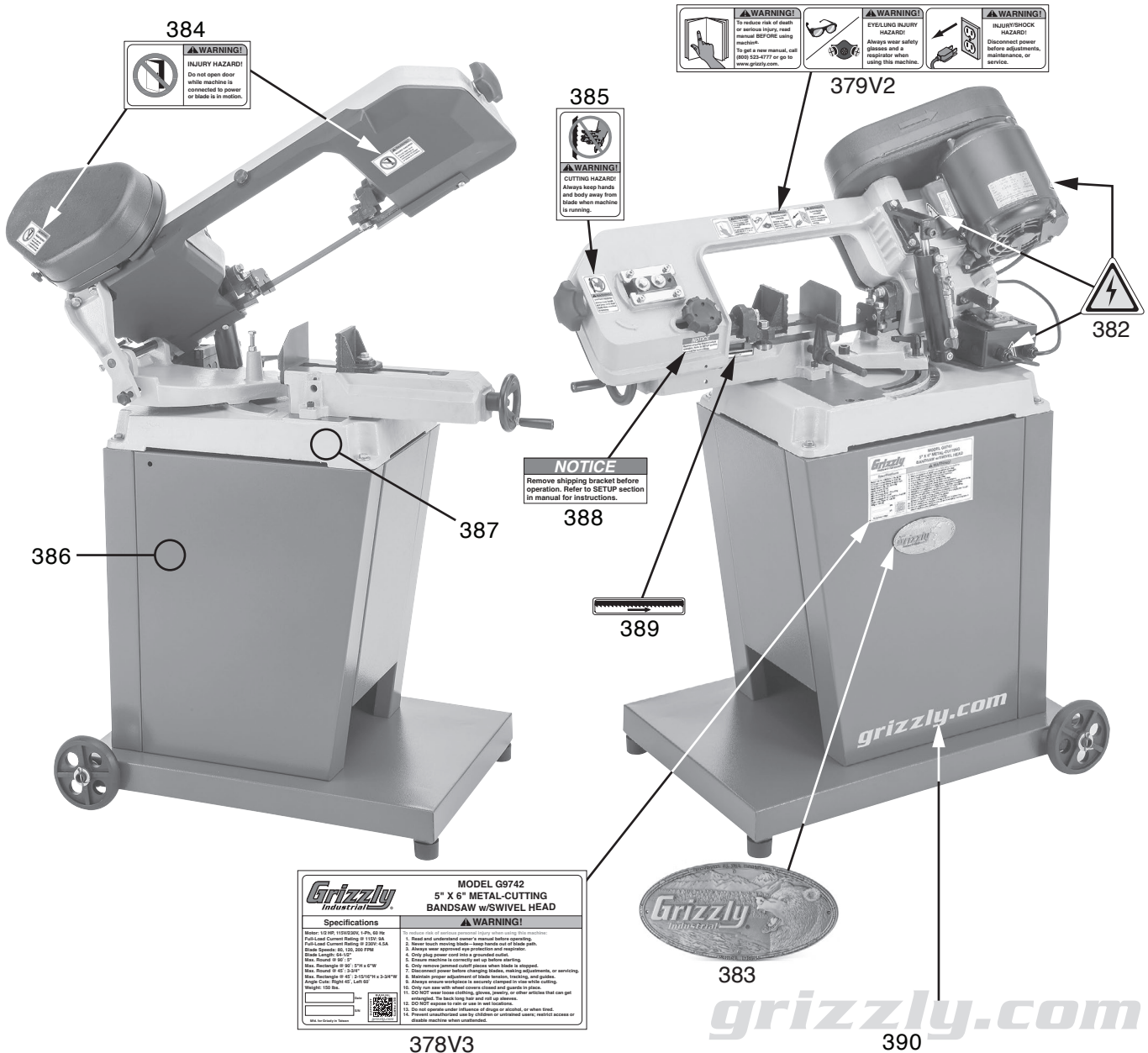

<b>Grizzly Industrial</b>		<b>MODEL G9742</b>	
<b>5" X 6" METAL-CUTTING BANDSAW w/SWIVEL HEAD</b>		<b>WARNING!</b>	
<b>Specifications</b> Motor: 3/4 HP, 115V/50 Hz Full-Load Current Rating: 11.15V 5A Full-Load Current Rating: 200V 6.5A Blade Capacity: 100, 100' PPM Blade Length: 60" 1/2" Max. Height: 9' 6" 1/2" Max. Height to 90°: 2'7" x 4'7" Max. Height to 45°: 2'10" x 3'3-3/4" Angle: Cuts: Right 45° Left 0° Height: 100 lbs.		1. Reduce risk of serious personal injury by reading the instruction. 2. Read and understand owner's manual before operating. 3. Never touch moving blades - never touch end of blade path. 4. Always wear appropriate eye protection and equipment. 5. Only plug power cord into a grounded outlet. 6. Check machine to ensure set up before starting. 7. Only remove jammed cutoff piece when blade is stopped. 8. Disconnect power before changing blades, making adjustments, or servicing. 9. Always ensure workpiece is securely clamped in vise while cutting. 10. Do not use with wheel covers closed and guards to place. 11. Do NOT wear loose clothing, gloves, jewelry, or other articles that can get caught in the tool. 12. DO NOT operate on side or end conditions. 13. Do not operate under influence of drugs or alcohol, or when tired. 14. Provide maintenance only by qualified or certified users; neither access or disable machine when unattended.	

REF	PART #	DESCRIPTION
378V3	P9742378V3	MACHINE ID LABEL V3.01.25
379V2	P9742379V2	COMBO WARNING LABEL V2.01.25
382	P9742382	ELECTRICITY LABEL
383	P9742383	GRIZZLY LOGO PLATE
384	P9742384	DO NOT OPEN DOOR LABEL
385	P9742385	CUTTING HAZARD LABEL

REF	PART #	DESCRIPTION
386	P9742386	TOUCH-UP PAINT, GRIZZLY GREEN
387	P9742387	TOUCH-UP PAINT, GRIZZLY BEIGE
388	P9742388	SHIPPING BRACKET LABEL
389	P9742389	BLADE DIRECTION LABEL
390	P9742390	GRIZZLY.COM LABEL

**WARNING**

Safety labels help reduce the risk of serious injury caused by machine hazards. If any label comes off or becomes unreadable, the owner of this machine **MUST** replace it in the original location before resuming operations. For replacements, contact (800) 523-4777 or [www.grizzly.com](http://www.grizzly.com).

# **Grizzly** **Industrial, Inc.**®

## **MODEL G9742** **5" x 6" METAL-CUTTING** **BANDSAW w/ SWIVEL HEAD** **OWNER'S MANUAL** *(For models manufactured since 11/06)*



COPYRIGHT © NOVEMBER, 2005 BY GRIZZLY INDUSTRIAL, INC. REVISED JULY, 2018 (HE)  
**WARNING: NO PORTION OF THIS MANUAL MAY BE REPRODUCED IN ANY SHAPE  
OR FORM WITHOUT THE WRITTEN APPROVAL OF GRIZZLY INDUSTRIAL, INC.**  
#PC7670 PRINTED IN CHINA



## **WARNING!**

**This manual provides critical safety instructions on the proper setup, operation, maintenance, and service of this machine/tool. Save this document, refer to it often, and use it to instruct other operators.**

**Failure to read, understand and follow the instructions in this manual may result in fire or serious personal injury—including amputation, electrocution, or death.**

**The owner of this machine/tool is solely responsible for its safe use. This responsibility includes but is not limited to proper installation in a safe environment, personnel training and usage authorization, proper inspection and maintenance, manual availability and comprehension, application of safety devices, cutting/sanding/grinding tool integrity, and the usage of personal protective equipment.**

**The manufacturer will not be held liable for injury or property damage from negligence, improper training, machine modifications or misuse.**



## **WARNING!**

**Some dust created by power sanding, sawing, grinding, drilling, and other construction activities contains chemicals known to the State of California to cause cancer, birth defects or other reproductive harm. Some examples of these chemicals are:**

- **Lead from lead-based paints.**
- **Crystalline silica from bricks, cement and other masonry products.**
- **Arsenic and chromium from chemically-treated lumber.**

**Your risk from these exposures varies, depending on how often you do this type of work. To reduce your exposure to these chemicals: Work in a well ventilated area, and work with approved safety equipment, such as those dust masks that are specially designed to filter out microscopic particles.**

# Table of Contents

<b>INTRODUCTION.....</b>	<b>2</b>	<b>SECTION 4: OPERATIONS .....</b>	<b>19</b>
Foreword.....	2	Operation Safety .....	19
Contact Info.....	2	Blade Speed .....	19
Machine Data Sheet .....	3	Blade Selection .....	20
Identification.....	5	Feed Rate .....	21
<b>SECTION 1: SAFETY.....</b>	<b>6</b>	Blade Guides .....	22
Safety Instructions for Machinery .....	6	Blade Tension.....	23
Additional Safety Instructions for Metal Cutting		Operation Tips .....	23
Bandsaws .....	8	<b>SECTION 5: ACCESSORIES.....</b>	<b>24</b>
<b>SECTION 2: CIRCUIT REQUIREMENTS .....</b>	<b>9</b>	<b>SECTION 6: MAINTENANCE.....</b>	<b>26</b>
110/220V Operation.....	9	Schedule .....	26
<b>SECTION 3: SET UP .....</b>	<b>10</b>	Cleaning.....	26
Set Up Safety.....	10	Lubrication .....	26
Items Needed for Set Up .....	10	<b>SECTION 7: SERVICE .....</b>	<b>27</b>
Unpacking .....	10	Troubleshooting .....	27
Inventory .....	11	Blade Change .....	29
Clean Up.....	12	Blade Tracking.....	30
Site Considerations.....	12	Electrical Components.....	31
Cabinet, Wheels & Feet.....	13	G9742 Wiring Diagram .....	32
Squaring Vise to Blade .....	15	Saw Parts Breakdown .....	33
Chip Tray & Cast Iron Stop.....	16	Stand Parts Breakdown .....	35
OFF Button Lever .....	16	Guides & Shafts Parts Breakdown .....	37
Pulley Cover.....	17	Labels Parts Breakdown.....	38
Test Run .....	18	<b>WARRANTY AND RETURNS .....</b>	<b>41</b>
Recommended Adjustments.....	18		

# INTRODUCTION

---

---

## Foreword

---

---

We are proud to offer the Model G9742 5" x 6" Metal-Cutting Bandsaw with Swivel Head. This machine is part of a growing Grizzly family of fine metalworking machinery. When used according to the guidelines set forth in this manual, you can expect years of trouble-free, enjoyable operation and proof of Grizzly's commitment to customer satisfaction.

We are pleased to provide this manual with the Model G9742. It was written to guide you through assembly, review safety considerations, and cover general operating procedures. It represents our effort to produce the best documentation possible.

The specifications, drawings, and photographs illustrated in this manual represent the Model G9742 as supplied when the manual was prepared. However, owing to Grizzly's policy of continuous improvement, changes may be made at any time with no obligation on the part of Grizzly. For your convenience, we always keep current Grizzly manuals available on our website at **www.grizzly.com**. Any updates to your machine will be reflected in these manuals as soon as they are complete. Visit our site often to check for the latest updates to this manual!

## Contact Info

---

---

If you have any comments regarding this manual, please write to us at the address below:

Grizzly Industrial, Inc.  
c/o Technical Documentation Manager  
P.O. Box 2069  
Bellingham, WA 98227-2069

We stand behind our machines. If you have any service questions or parts requests, please call or write us at the location listed below.

Grizzly Industrial, Inc.  
1203 Lycoming Mall Circle  
Muncy, PA 17756  
Phone: (570) 546-9663  
Fax: (800) 438-5901  
E-Mail: [techsupport@grizzly.com](mailto:techsupport@grizzly.com)  
Web Site: <http://www.grizzly.com>





# MACHINE DATA SHEET

Customer Service #: (570) 546-9663 · To Order Call: (800) 523-4777 · Fax #: (800) 438-5901

## MODEL G9742 5" X 6" METAL-CUTTING BANDSAW W/ SWIVEL HEAD

### Product Dimensions:

Weight..... 150 lbs.  
Width (side-to-side) x Depth (front-to-back) x Height..... 39 x 23-3/8 x 54-3/4 in.  
Footprint (Length x Width)..... 26-1/2 x 20-1/2 in.

### Shipping Dimensions:

Type..... Cardboard  
Content..... Machine  
Weight..... 168 lbs.  
Length x Width x Height..... 41 x 18 x 22 in.  
Must Ship Upright..... Yes

### Electrical:

Power Requirement..... 110V or 220V, Single-Phase, 60 Hz  
Prewired Voltage..... 110V  
Full-Load Current Rating..... 8.8A at 110V, 4.4A at 220V  
Minimum Circuit Size..... 15A at 110V, 15A at 220V  
Connection Type..... Cord & Plug  
Power Cord Included..... Yes  
Power Cord Length..... 6 ft.  
Power Cord Gauge..... 18 AWG  
Plug Included..... Yes  
Included Plug Type..... 5-15 for 110V  
Recommended Plug Type..... 6-15 for 220V  
Switch Type..... Sealed Button Switch w/Automatic Shut-Off

### Motors:

#### Main

Horsepower..... 1/2 HP  
Phase..... Single-Phase  
Amps..... 8.8A/4.4A  
Speed..... 1725 RPM  
Type..... TEFC Capacitor-Start Induction  
Power Transfer ..... V-Belt Drive  
Bearings..... Shielded & Permanently Lubricated  
Centrifugal Switch/Contacts Type..... External

### Main Specifications:

#### Operation Info

Blade Speeds..... 80, 120, 200 FPM  
Std. Blade Length..... 64-1/2 in.  
Blade Size Range..... 1/2 in.  
Head Swivel..... 45 deg.



## Cutting Capacities

Angle Cuts.....	Right 45, Left 60 deg.
Vise Jaw Depth.....	4-3/8 in.
Vise Jaw Height.....	2-1/2 in.
Max. Capacity Rectangular Height at 90 Deg.....	5 in.
Max. Capacity Rectangular Width at 90 Deg.....	6 in.
Max. Capacity Round at 90 Deg.....	5 in.
Max. Capacity Rectangular Height at 30 Deg.....	5 in.
Max. Capacity Rectangular Width at 30 Deg.....	5 in.
Max. Capacity Round at 30 Deg.....	5 in.
Max. Capacity Rectangular Height at 45 Deg.....	2-15/16 in.
Max. Capacity Rectangular Width at 45 Deg.....	3-3/4 in.
Max. Capacity Round at 45 Deg.....	3-3/4 in.
Max. Capacity Rectangular Height at 60 Deg.....	1-3/4 in.
Max. Capacity Rectangular Width at 60 Deg.....	2-3/16 in.
Max. Capacity Round at 60 Deg.....	1-3/4 in.

## Construction

Table.....	Precision Ground Cast Iron
Upper Wheel.....	Machined Cast Iron
Lower Wheel.....	Machined Cast Iron
Body.....	Cast Iron
Base.....	Formed and Welded Steel with Coolant Sump
Wheel Cover.....	Pre-formed Steel
Paint Type/Finish.....	Epoxy

## Other

Wheel Size.....	13 in.
Blade Guides Upper.....	Ball Bearing
Blade Guides Lower.....	Ball Bearing

## Table Info

Table Size Length.....	12 in.
Table Size Width.....	4-1/2 in.
Floor To Cutting Area Height.....	29 in.

## Other Specifications:

Country of Origin .....	China
Warranty .....	1 Year
Approximate Assembly & Setup Time .....	30 Minutes
Serial Number Location .....	ID Label on Body Frame
ISO 9001 Factory .....	Yes
Certified by a Nationally Recognized Testing Laboratory (NRTL) .....	No

## Features:

Control Panel Conveniently Located  
Adjustable Hydraulic Downfeed  
Quick Release Vise for Rapid Change-out of Workpiece  
Blade Included



# Identification

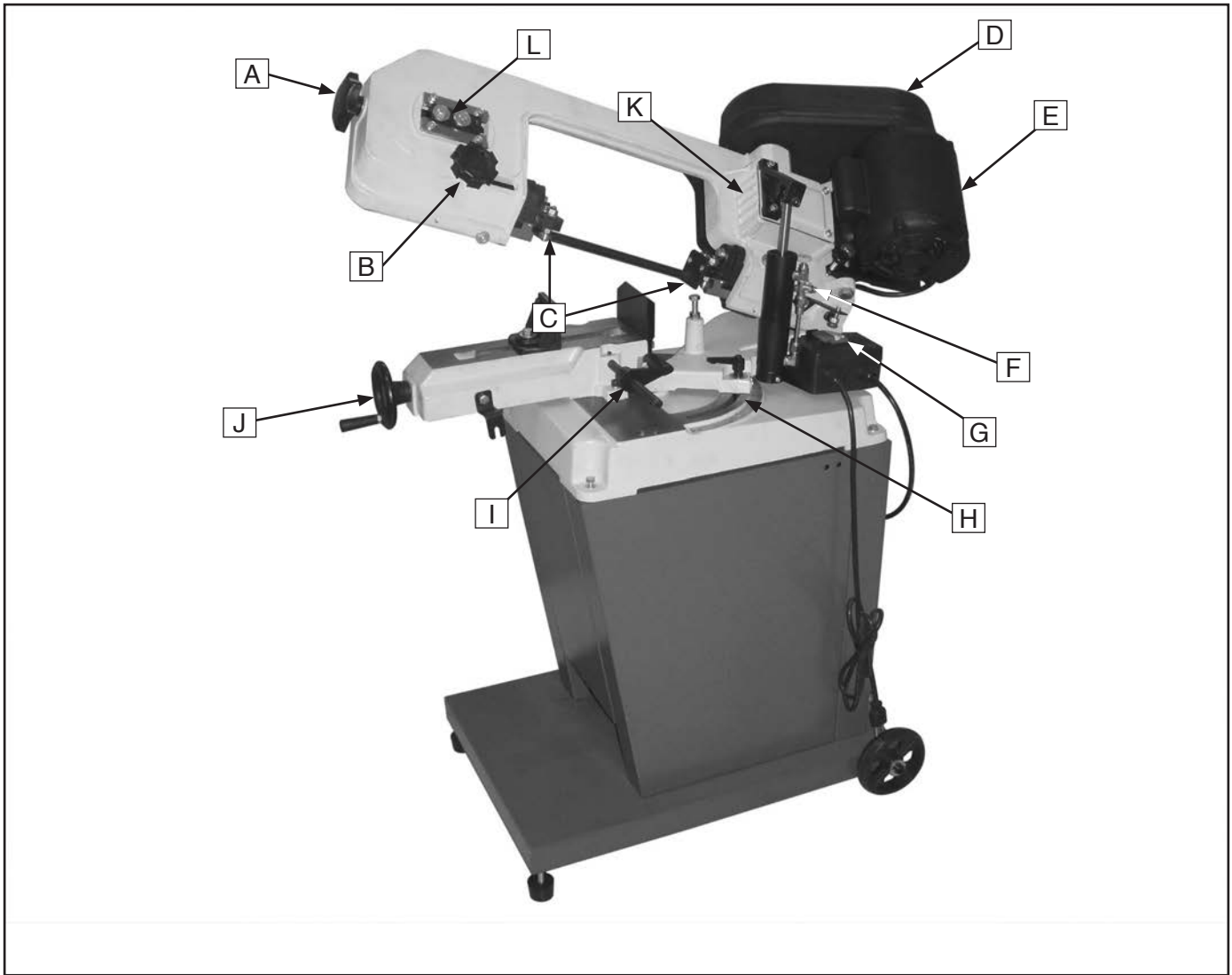

**Figure 1.** The Model G9742.

- A.** Blade Tension Knob
- B.** Blade Guide Knob
- C.** Blade Guides
- D.** Pulley Cover
- E.** Heavy Duty Motor
- F.** Hydraulic Cylinder and Feed Rate Dial
- G.** ON/OFF Push-Button Switch Assembly
- H.** Table Angle Scale
- I.** Cast Iron Stop
- J.** Vise Clamp Handwheel
- K.** Gear Box
- L.** Blade Tension Gauge



# SECTION 1: SAFETY

## WARNING

### For Your Own Safety, Read Instruction Manual Before Operating this Machine

The purpose of safety symbols is to attract your attention to possible hazardous conditions. This manual uses a series of symbols and signal words intended to convey the level of importance of the safety messages. The progression of symbols is described below. Remember that safety messages by themselves do not eliminate danger and are not a substitute for proper accident prevention measures.



Indicates an imminently hazardous situation which, if not avoided, **WILL** result in death or serious injury.



Indicates a potentially hazardous situation which, if not avoided, **COULD** result in death or serious injury.



Indicates a potentially hazardous situation which, if not avoided, **MAY** result in minor or moderate injury. It may also be used to alert against unsafe practices.

**NOTICE**

This symbol is used to alert the user to useful information about proper operation of the machine.

## WARNING

### Safety Instructions for Machinery

**OWNER'S MANUAL.** Read and understand this owner's manual **BEFORE** using machine. Untrained users can be seriously hurt.

**EYE PROTECTION.** Always wear ANSI-approved safety glasses or a face shield when operating or observing machinery. to reduce the risk of eye injury or blindness from flying particles Everyday eyeglasses are not approved safety glasses.

**HAZARDOUS DUST.** Dust created while using machinery may cause cancer, birth defects, or long-term respiratory damage. Be aware of dust hazards associated with each workpiece material, and always wear a NIOSH-approved respirator to reduce your risk.

**WEARING PROPER APPAREL.** Do not wear clothing, apparel, or jewelry that can become entangled in moving parts. Always tie back or cover long hair. Wear non-slip footwear to avoid accidental slips which could cause a loss of workpiece control.

**HEARING PROTECTION.** Always wear hearing protection when operating or observing loud machinery. Extended exposure to this noise without hearing protection can cause permanent hearing loss.

**MENTAL ALERTNESS.** Be mentally alert when running machinery. Never operate under the influence of drugs or alcohol, when tired, or when distracted.



# SECTION 1: SAFETY

## WARNING

### For Your Own Safety, Read Instruction Manual Before Operating this Machine

The purpose of safety symbols is to attract your attention to possible hazardous conditions. This manual uses a series of symbols and signal words intended to convey the level of importance of the safety messages. The progression of symbols is described below. Remember that safety messages by themselves do not eliminate danger and are not a substitute for proper accident prevention measures.



Indicates an imminently hazardous situation which, if not avoided, **WILL** result in death or serious injury.



Indicates a potentially hazardous situation which, if not avoided, **COULD** result in death or serious injury.



Indicates a potentially hazardous situation which, if not avoided, **MAY** result in minor or moderate injury. It may also be used to alert against unsafe practices.

### **NOTICE**

This symbol is used to alert the user to useful information about proper operation of the machine.

## WARNING

### Safety Instructions for Machinery

**OWNER'S MANUAL.** Read and understand this owner's manual **BEFORE** using machine. Untrained users can be seriously hurt.

**EYE PROTECTION.** Always wear ANSI-approved safety glasses or a face shield when operating or observing machinery. to reduce the risk of eye injury or blindness from flying particles Everyday eyeglasses are not approved safety glasses.

**HAZARDOUS DUST.** Dust created while using machinery may cause cancer, birth defects, or long-term respiratory damage. Be aware of dust hazards associated with each workpiece material, and always wear a NIOSH-approved respirator to reduce your risk.

**WEARING PROPER APPAREL.** Do not wear clothing, apparel, or jewelry that can become entangled in moving parts. Always tie back or cover long hair. Wear non-slip footwear to avoid accidental slips which could cause a loss of workpiece control.

**HEARING PROTECTION.** Always wear hearing protection when operating or observing loud machinery. Extended exposure to this noise without hearing protection can cause permanent hearing loss.

**MENTAL ALERTNESS.** Be mentally alert when running machinery. Never operate under the influence of drugs or alcohol, when tired, or when distracted.



## **WARNING**

# Additional Safety Instructions for Metal Cutting Bandsaws

- 1. BLADE CONDITION.** Do not operate with dull, cracked or badly worn blade. Inspect blades for cracks and missing teeth before each use.
- 2. HAND PLACEMENT.** Never position fingers or thumbs in line with the cut. Hands could be crushed in vise or by falling machine components.
- 3. ENTANGLEMENT HAZARDS.** Do not operate this bandsaw without blade guard in place. Otherwise, loose clothing, jewelry, long hair and work gloves can be drawn into working parts.
- 4. BLADE REPLACEMENT.** When replacing blades, make sure teeth face toward the workpiece. Wear gloves to protect hands and safety glasses to protect eyes.
- 5. WORKPIECE HANDLING.** Always support the workpiece with table, vise, or some type of support fixture. Flag long pieces to avoid a tripping hazard. Never hold the workpiece with your hands during a cut.
- 6. LOSS OF STABILITY.** Unsupported workpieces may jeopardize machine stability and cause the machine to tip and fall which could cause serious injury.
- 7. POWER INTERRUPTION.** Unplug machine after power interruption. Machines without magnetic switches can start up after power is restored.
- 8. FIRE HAZARD.** Use EXTREME CAUTION if cutting magnesium. Using the wrong cutting fluid will lead to chip fire and possible explosion.
- 9. CUTTING FLUID SAFETY.** Always follow manufacturer's cutting fluid safety instructions. Pay particular attention to contact, contamination, inhalation, storage and disposal warnings. Spilled cutting fluid is a slipping hazard.
- 10. ATTENTION TO WORK AREA.** Never leave a machine running and unattended. Pay attention to the actions of others in the area to avoid unintended accidents.
- 11. MAINTENANCE/SERVICE.** All inspections, adjustments, and maintenance are to be done with the machine **OFF** and the plug pulled from the outlet. Wait for all moving parts to come to a complete stop.
- 12. HEARING PROTECTION & HAZARDS.** Noise generated by blade and workpiece vibration, material handling, and power transmission can cause permanent hearing loss over time and interfere with communication and audible signals. Always wear hearing protection.
- 13. HOT SURFACES.** Due to friction, the workpiece, chips, and some machine components can be hot enough to burn you.

## **WARNING**

No list of safety guidelines can be complete. Every shop environment is different. Like all machines there is danger associated with the Model G9742. Accidents are frequently caused by lack of familiarity or failure to pay attention. Use this machine with respect and caution to lessen the possibility of operator injury. If normal safety precautions are overlooked or ignored, serious personal injury may occur.



# SECTION 2: CIRCUIT REQUIREMENTS

## 110/220V Operation

### **!WARNING**

Serious personal injury could occur if you connect the machine to power before completing the setup process. **DO NOT** connect the machine to the power until instructed later in this manual.



### **!WARNING**

Electrocution or fire could result if machine is not grounded and installed in compliance with electrical codes. Compliance **MUST** be verified by a qualified electrician!

### **NOTICE**

The Model G9742 is prewired for 110V operation. If you plan to operate your machine at 220V, the motor must be rewired (see Page 32).

### Full Load Amperage Draw

Amp Draw at 110V (prewired)..... 7 Amps  
 Amp Draw at 220V ..... 3.5 Amps

### Power Supply Circuit Requirements

You **MUST** connect your machine to a grounded circuit that is rated for the amperage given below. Never replace a circuit breaker on an existing circuit with one of higher amperage without consulting a qualified electrician to ensure compliance with wiring codes. **If you are unsure about the wiring codes in your area or you plan to connect your machine to a shared circuit, consult a qualified electrician.**

Minimum Circuit Size (110V)..... 15 Amps  
 Minimum Circuit Size (220V)..... 15 Amps

### Power Connection Device

The Model G9742 comes prewired with a NEMA 5-15 plug for connection to power. If you rewire the motor to 220V, we recommend using the plug and receptacle shown in **Figure 2** for 220V.

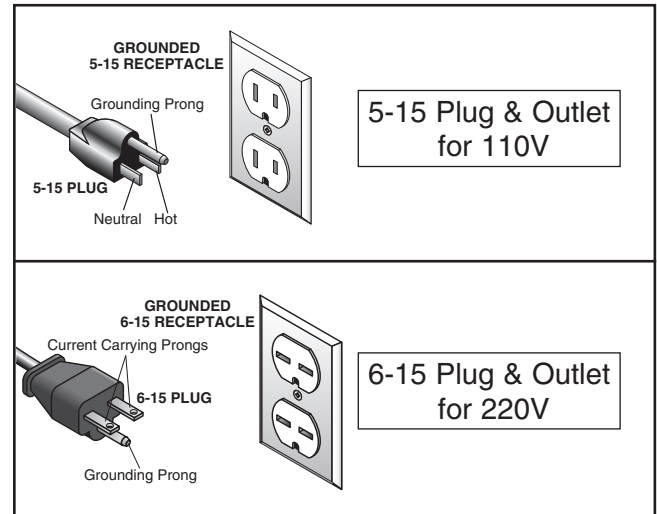

**Figure 2.** Recommended plug types.

### Extension Cords

Using extension cords may reduce the life of the motor. Instead, place the machine near a power source. If you must use an extension cord:

- For 110V, use at least a 14 gauge cord that does not exceed 50 feet in length.
- For 220V, use at least a 14 gauge cord that does not exceed 50 feet in length.
- The extension cord must have a ground wire and plug pin.





# Inventory

After all the parts have been removed from the box, you should have the following items:

<b>Box 1: (Figure 3)</b>	<b>Qty</b>
A. Base .....	1
B. Front Panel .....	1
C. Rear Panel .....	1
D. Right Panel .....	1
E. Left Panel .....	1
F. Chip Tray .....	1
G. Feet .....	4
H. Wheels .....	2
I. Axle .....	1
J. Work Stop Shaft .....	1
K. Work Stop .....	1
L. Belt Cover .....	1
M. V-Belt .....	1

## Assembly Hardware:

—Hex Wrench 4mm .....	1
—Hex Bolt $\frac{3}{8}$ -16 x 1" .....	2
—Hex Bolt M8-1.25 x 30 .....	4
—Flat Washer 17mm (Wheels) .....	4
—Flat Washer 8mm .....	4
—Cotter Pin $\frac{1}{8}$ x 1 (Wheels) .....	2
—Hex Nut $\frac{3}{8}$ -16 (Feet) .....	4
—Flat Washer $\frac{3}{8}$ .....	1
—Phillips Head Screw M6-1 x 12 .....	16
—Flat Washer $\frac{1}{4}$ .....	18
—Hex Bolt $\frac{1}{4}$ x 20 x $\frac{1}{2}$ " .....	2
—Sheet Metal Screw $\frac{1}{4}$ -10 x $\frac{5}{16}$ " .....	1

In the event that any nonproprietary parts are missing (e.g. a nut or a washer), we would be glad to replace them, or for the sake of expediency, replacements can be obtained at your local hardware store.

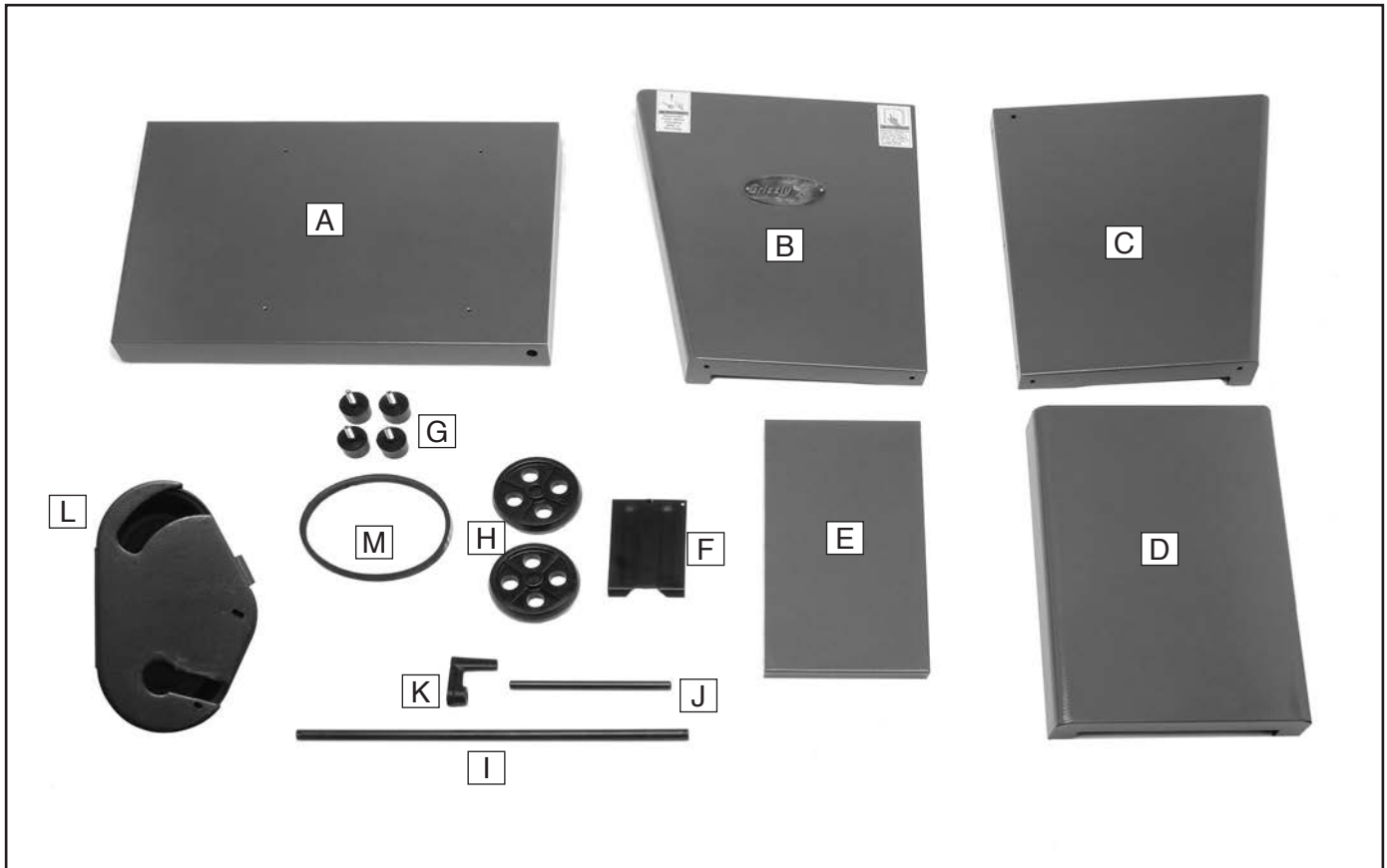

**Figure 3.** G9742 Loose parts inventory.



# Clean Up

The unpainted surfaces are coated with a waxy oil to prevent corrosion during shipment. Remove this protective coating with a solvent cleaner or degreaser, such as shown in **Figure 4**. For thorough cleaning, some parts must be removed. **For optimum performance, clean all moving parts or sliding contact surfaces.** Avoid chlorine-based solvents, such as acetone or brake parts cleaner that may damage painted surfaces. Always follow the manufacturer's instructions when using any type of cleaning product.

	<p><b>! WARNING</b> Gasoline and petroleum products have low flash points and can explode or cause fire if used to clean machinery. <b>DO NOT</b> use these products to clean the machinery.</p>
---	--

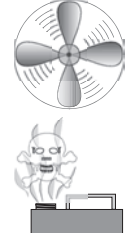
	<p><b>! CAUTION</b> Many cleaning solvents are toxic if inhaled. Minimize your risk by only using these products in a well ventilated area.</p>
---	---

## G2544—Solvent Cleaner & Degreaser

A great product for removing the waxy shipping grease from your machine during clean up.

<p>Call <b>1-800-523-4777</b> To Order</p>	
--	---

**Figure 4.** Cleaner/degreaser available from Grizzly.

# Site Considerations

## Floor Load

Refer to the **Machine Data Sheet** for the weight and footprint specifications of your machine. Some floors may require additional reinforcement to support both the machine and operator.

## Working Clearances

Consider existing and anticipated needs, size of material to be processed through each machine, and space for auxiliary stands, work tables or other machinery when establishing a location for your new machine. See **Figure 5** for the minimum working clearances.

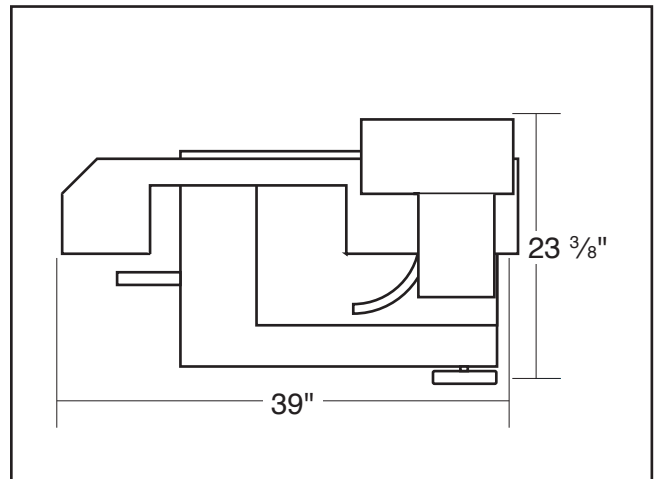

**Figure 5.** Minimum working clearances.

	<p><b>! CAUTION</b> Unsupervised children and visitors inside your shop could cause serious personal injury to themselves. Lock all entrances to the shop when you are away and <b>DO NOT</b> allow unsupervised children or visitors in your shop at any time!</p>
--	---



# Cabinet, Wheels & Feet

This bandsaw is shipped with four rubber feet with posts and two wheels with an axle. It is your option to install four rubber feet if you do not need to move the bandsaw, or install the axle and wheels if you need to move the bandsaw regularly.

<b>Components and Hardware Needed:</b>	<b>Qty</b>
Base .....	1
Front Panel .....	1
Rear Panel.....	1
Right Panel.....	1
Left Panel .....	1
Ramp.....	1
Feet .....	4
Wheels.....	2
Axle .....	1
—Flat Washers 17mm.....	4
—Cotter Pins.....	2
—Hex Nuts $\frac{3}{8}$ -16.....	4
—Phillips Head Screw M6-1 x 12.....	16
—Flat Washer $\frac{1}{4}$ .....	16
—Hex Bolt M8-1.25 x 30 .....	4
—Flat Washer 8mm .....	4

## To install the wheels, feet, and the cabinet:

1. At the end of the base with the axle holes, insert the axle into the base (see **Figure 6**).
2. Slide a 17mm flat washer and wheel onto each end of the axle, followed by another washer and cotter pin.
3. Thread a  $\frac{3}{8}$ -16 hex nut on both feet.
4. Thread the two rubber feet into the base (see **Figure 6**).

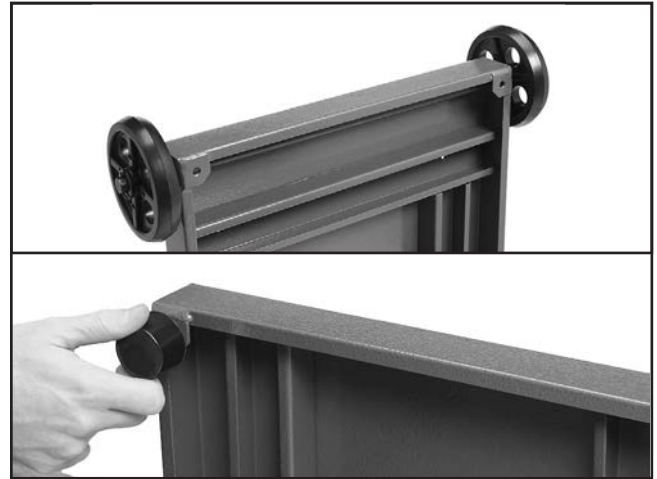

**Figure 6.** Installing wheels and feet.

5. Position the base on the floor, and adjust the feet until the base is level and is stable.
6. Tighten the hex nuts against the base to lock the feet in position.
7. Position the front and rear panels on the base and install the panels to the base with four M6-1 x 12 Phillips head screws and flat washers (see **Figure 7**).



**Figure 7.** Front and rear panels installed.



8. Position the left panel between the front and rear panels, and secure it in place with six M6-1 x 12 Phillips head screws and flat washers (see **Figure 8**).

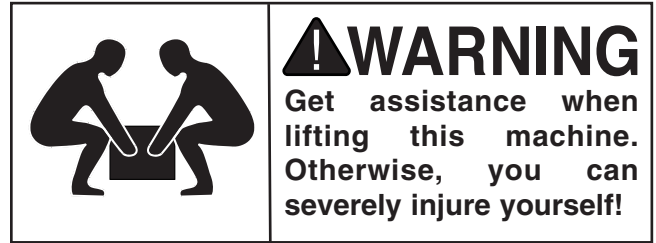

**Figure 8.** Left Panel installed.

9. Position the right panel between the front and rear panel, and secure it in place with six M6-1 x 12 Phillips head screws and flat washers (see **Figure 9**).



**Figure 9.** Installing right panel.



10. With the help of an assistant or a hoisting device, place the bandsaw onto the cabinet.
11. Secure the bandsaw to the cabinet with four M8-1.25 x 30 hex bolts and 8mm flat washers (see **Figure 10**).

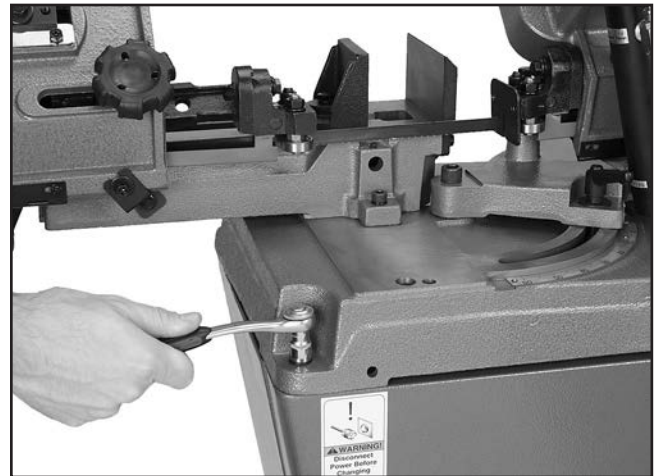

**Figure 10.** Attaching bandsaw to cabinet.



# Shipping Strap & Stop Adjustment

To ensure that your bandsaw arrives without damage to the hinge system, a shipping strap was installed. After removing the shipping strap, you will have to make a series of adjustments, beginning with the feed stop bolt.

## To remove the shipping strap and adjust the feed stop bolt:

1. Remove the shipping strap hex bolt and strap with a 12mm wrench (see **Figure 11**).

**Note:** *Keep this shipping strap in the event that you must transport or ship the bandsaw.*

2. Adjust the feed stop bolt and jam nut with a 14mm wrench (**Figure 12**), so the bandsaw blade teeth are just below the table surface when the cut is complete.

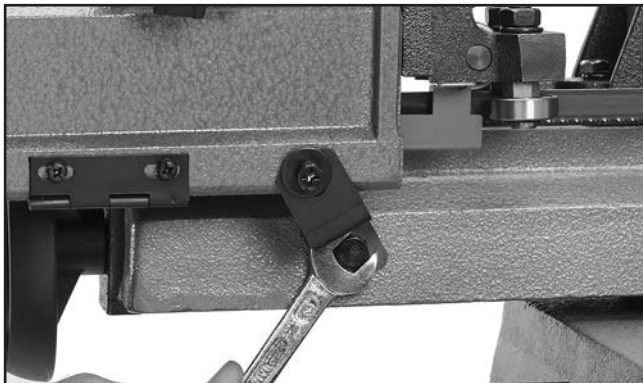

**Figure 11.** Removing shipping strap.



**Figure 12.** Feed stop bolt.

# Squaring Vise to Blade

To ensure that your bandsaw will make cuts that match the degree scale, you must make sure to square the vise to the blade.

## To square the vise to the blade:

1. Rotate the headstock until the pointer reads "0" on the tabletop scale, and tighten the headstock lock lever so the headstock stays indexed at zero.
2. Using a 6mm wrench, loosen the two cap screws that hold the vise to the table (see **Figure 13**).

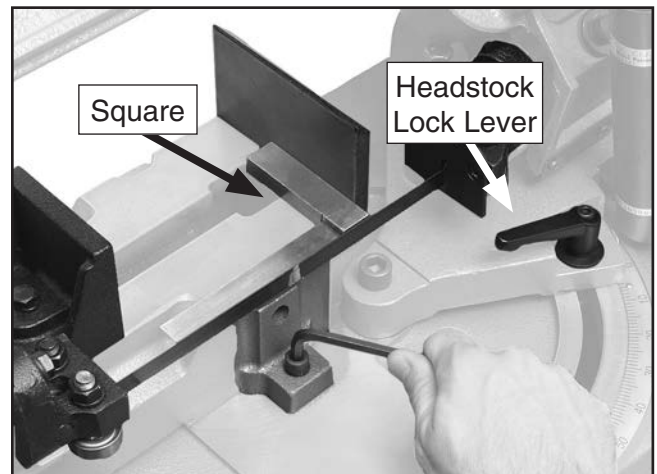

**Figure 13.** Squaring vise to blade, headstock, and table scale.

3. Using a small machinists square, adjust the vise so it is square to the blade.
4. Tighten the two cap screws, so the vise and blade are square with one another.



# Chip Tray & Cast Iron Stop

The chip tray directs small workpieces into a bucket when the cut is complete. The cast iron stop allows you to repeat cuts at the same length.

## To install the chip tray and cast iron stop:

1. Position the chip tray as shown in **Figure 14** if you choose to use this accessory.

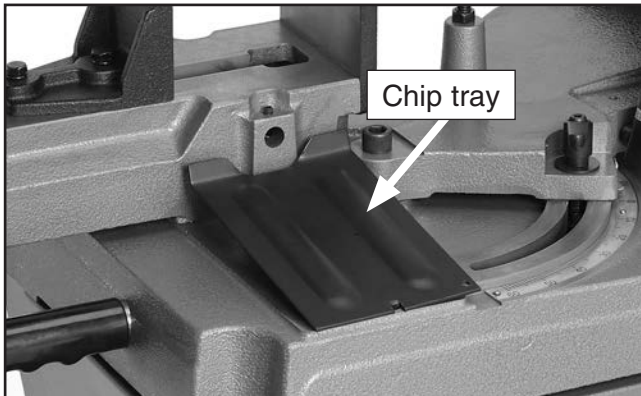

**Figure 14.** Chip tray installed.

2. Insert the stop rod approximately  $\frac{3}{4}$ " into the saw until the end of the rod is just flush with the inside casting surface.
3. Using the 4mm hex wrench, tighten the set screw shown in **Figure 15**.

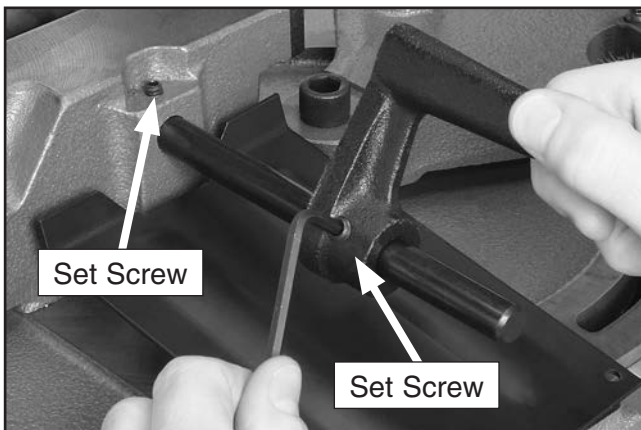

**Figure 15.** Installing stop rod.

4. Slide the cast iron stop onto the stop rod and tighten the set screw.

# OFF Button Lever

After you have removed the shipping strap and have adjusted the headstock stop bolt, you must adjust the OFF button lever stop bolt, so the bandsaw shuts OFF automatically when a cut is complete.

## To set the OFF button lever stop bolt:

1. With the headstock in the complete down position, loosen the 12mm stop bolt and jam nut (see **Figure 16**).

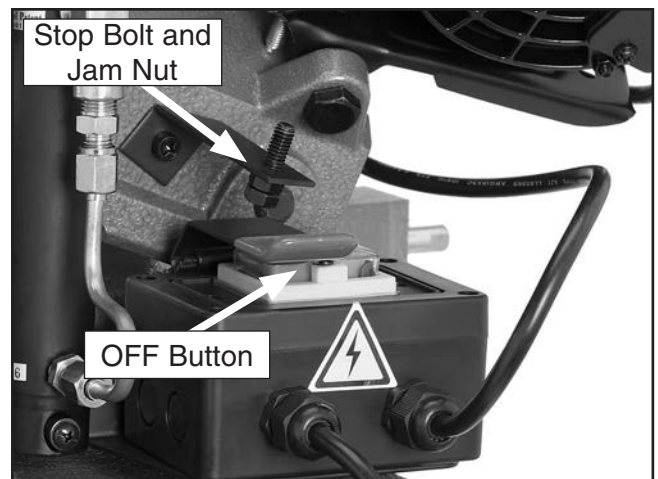

**Figure 16.** OFF button lever and stop bolt.

2. Push down on the OFF button lever so the button is completely depressed.
3. While keeping the lever depressed, use your fingertips to turn the stop bolt until the head touches the lever.
4. Back off the stop bolt  $\frac{1}{8}$  turn and tighten the jam nut.



# Pulley Cover

When opened, the pulley cover gives you access to change the pulley ratio so the bandsaw can cut at one of three speeds.



To install the pulley cover:

1. UNPLUG THE BANDSAW!
2. Position and rotate the pulley cover into place as shown in **Figure 17**.
3. Install the two 1/4-20 x 1/2" hex bolts and washers that secure the pulley cover.

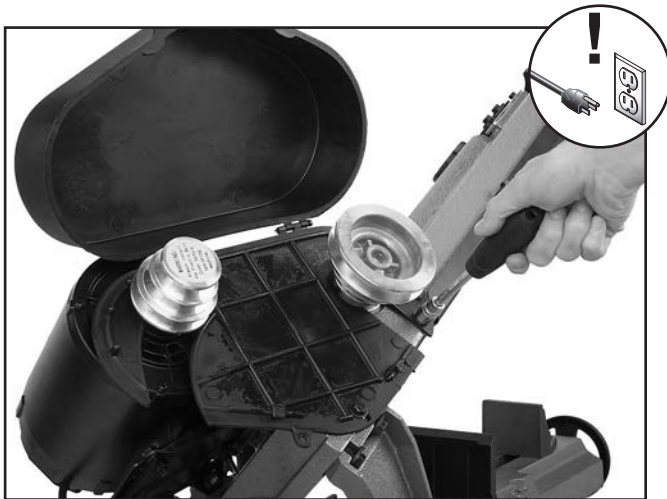

**Figure 17.** Positioning the pulley cover.

4. Loosen the belt tension knob enough to install the belt on the appropriate pulley that will give the required blade speed. Refer to **Blade Speed** on **Page 19** for blade speed selections.
5. Adjust the belt tension knob (**Figure 18**), so the belt has 1/4" deflection when pressed in the center, and close the cover.

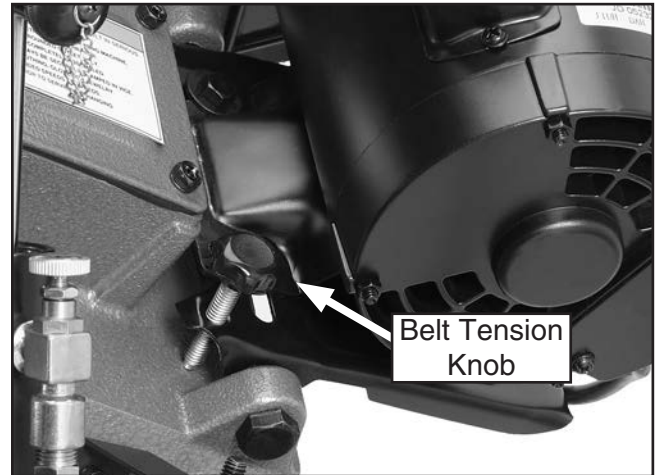

**Figure 18.** Belt tension knob.



# Test Run

---

---

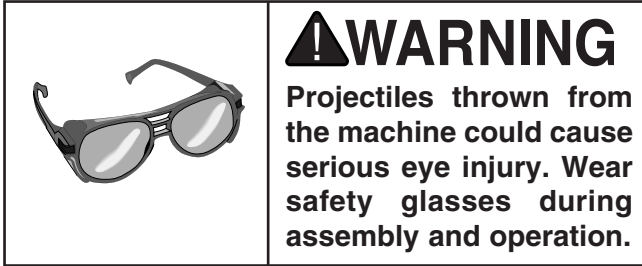

## Starting the machine:

1. Read the entire instruction manual.
2. Make sure all tools and foreign objects have been removed from the machine.
3. Put on safety glasses and secure loose clothing or long hair.
4. Raise the bandsaw by the handle.
5. Start the bandsaw while keeping your finger near the ON/OFF switch at all times during the test run. The bandsaw should run smoothly with little or no vibration.

— If you suspect any problems, immediately stop the bandsaw and correct before continuing.

—If you need any help with your bandsaw call our Tech Support at (570) 546-9663.

# Recommended Adjustments

---

---

The adjustments listed below have been performed at the factory. However, because of the many variables involved with shipping, we recommend that you at least verify the following adjustments to ensure the adjustments remain unchanged.

Step-by-step instructions on verifying these adjustments can be found in **SECTION 6: MAINTENANCE** on **Page 26** and **SECTION 7: SERVICE** on **Page 27**.

## Factory adjustments that should be verified:

1. Blade Tracking (**Page 30**).
2. Squaring Vise to Blade (**Page 15**).
3. Blade Guides (**Page 22**).



# SECTION 4: OPERATIONS

## Operation Safety

### ⚠️ WARNING

Damage to your eyes, lungs, and ears could result from using this machine without proper protective gear. Always wear safety glasses, a respirator, and hearing protection when operating this machine.

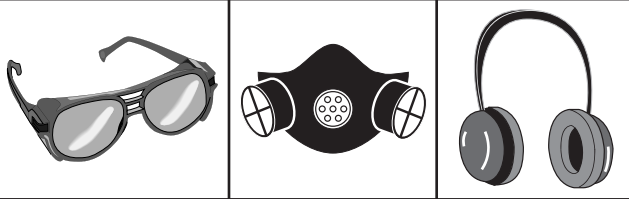

### ⚠️ WARNING

Loose hair and clothing could get caught in machinery and cause serious personal injury. Keep loose clothing and long hair away from moving machinery.

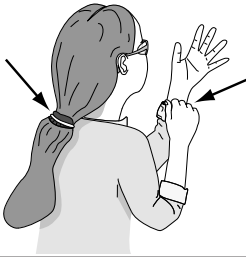

### NOTICE

If you have never used this type of machine or equipment before, WE STRONGLY RECOMMEND that you read books, trade magazines, or get formal training before beginning any projects. Regardless of the content in this section, Grizzly Industrial will not be held liable for accidents caused by lack of training.

## Blade Speed

The Model G9742 has these three blade speeds: 80, 120, and 200 FPM.

To change blade speeds:

1. UNPLUG THE BANDSAW!
2. Determine the best speed for your cut. The table in **Figure 19** is provided as a basic guideline. Material thickness and the type of blade used will factor into FPM selection.

Material	Feet Per Minute (FPM)
Aluminum	250
Plastics	800
Brass (soft)	500
Carbon Tool Steel	100-150
Cast Iron	100-150
Cold Rolled Steel	150-200
High Speed Steel	90-125
Malleable Iron	150-200
Hard Rubber	150-200

**Figure 19.** Blade speed table.

3. Slacken the V-belt and position it for the desired FPM (see **Figure 20**).

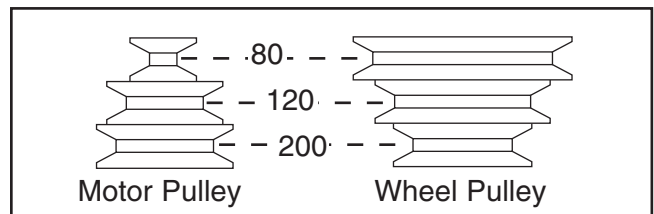

**Figure 20.** V-belt positions in FPM.

4. Tension the V-belt as described in the **Pulley Cover** section on **Page 17**.



# Blade Selection



The chart below is a basic starting point for choosing blade type based on teeth per inch (TPI) for variable tooth pitch blades and for standard raker type bimetal blades/HSS blades. However, for exact specifications of bandsaw blades, contact the blade manufacturer.

Here are some general rules of thumb with respect to bandsaw blade use.

- At least three teeth must contact the metal at any phase of the cut. Otherwise, the teeth can load up with metal, fracture, and break off. If the TPI is too high, the teeth can load up with material and overheat, damaging the blade.
- For a faster but rougher cut, use a blade with a lower TPI and a higher feed rate.
- For a slower but smoother cut, use a blade with more TPI and a lower feed rate.

## To select the correct blade TPI:

1. Measure the material thickness. This measurement is the length of cut taken from where the tooth enters the workpiece, sweeps through, and exits the workpiece.
2. Refer to the "Material Thickness" row of the blade selection chart in **Figure 21**, and read across to find the workpiece thickness you need to cut.
3. Refer to the "Shape" of metal and "Material Type" columns, and find the shape and material to be cut.
4. In the applicable row, read across to the right and find the box where the row and column intersect. Listed in the box is the minimum TPI recommended for the variable tooth pitch blades, and the TPI for bimetal raker blades in parentheses.

TOOTH SELECTION																				
mm	50	75	100	150	200	250	300	350	400	450										
	5/8		4/6		3/4			2/3												
	4/6	3/4		2/3		1.4/2.5			1.5/8											
	3/4		2/3		1.4/2.5			1.5/8												
inch	2	2½	3	3½	4	5	6	7	8	9	10	11	12	13	14	15	16	17	18	19

CUTTING SPEED RATE RECOMMENDATION							
Material	Speed FPM (M/Min)	Material	Speed FPM (M/Min)	Material	Speed FPM (M/Min)	Material	Speed FPM (M/Min)
Carbon Steel	196~354 (60) (108)	Tool Steel	203 (62)	Alloy Steel	111~321 (34) (98)	Free Machining Stainless Steel	150~203 (46) (62)
Angle Steel	180~220 (54) (67)	High-Speed Tool Steel	75~118 (25) (36)	Mold Steel	246 (75)	Gray Cast Iron	108~225 (33) (75)
Thin Tube	180~220 (54) (67)	Cold-Work Tool Steel	95~213 (29) (65)	Water Hardened Tool Steel	242 (75)	Ductile Austenitic Cast Iron	65~85 (20) (26)
Aluminum Alloy	220~534 (67) (163)	Hot-Work Tool Steel	203 (62)	Stainless Steel	85 (26)	Malleable Cast Iron	321 (98)
Copper Alloy	229~482 (70) (147)	Oil-Hardened Tool Steel	203~213 (62) (65)	CR Stainless Steel	85-203 (26) (62)	Plastics	220 (67)

Figure 21. Blade selection chart.



# Feed Rate

The speed at which the saw blade will cut through a workpiece is controlled by blade type and feed rate.

The feed rate is controlled by the valve lever and feed rate dial on the hydraulic cylinder shown in **Figure 22**.

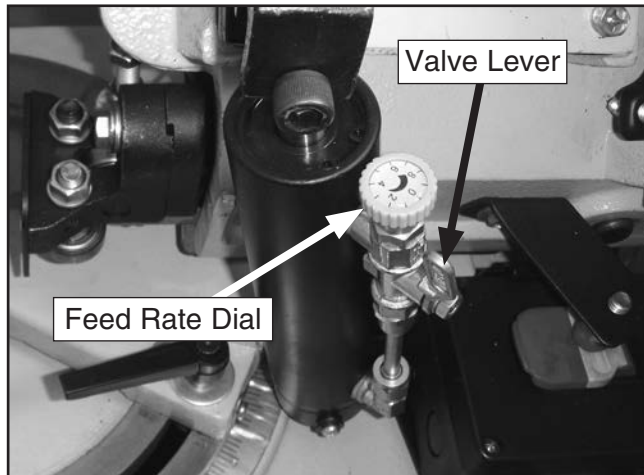

**Figure 22.** Bandsaw feed rate control.

Turning the valve lever in-line with the piping (as shown in the **Figure 22**) opens it up, which allows the fluid to circulate and allows the head to move. Turning the valve lever sideways or perpendicular to the piping closes it, which locks the headstock in place.

The feed rate dial controls the amount of fluid that circulates around the hydraulic cylinder, which in turn, controls the speed that it moves.

## To set the feed rate:

1. Raise the headstock and turn the valve lever sideways (horizontally).
2. Clamp the workpiece in the table vise.
3. Move the headstock and blade a few inches above the workpiece.
4. With the correct saw blade installed and blade speed selected, turn the saw **ON**.
5. Slowly rotate the feed rate dial to a conservative feed rate until the saw begins to cut the workpiece.
6. Observe the chips that exit the cut, and increase or decrease the feed rate according to the chip characteristics (see **Figure 23**).

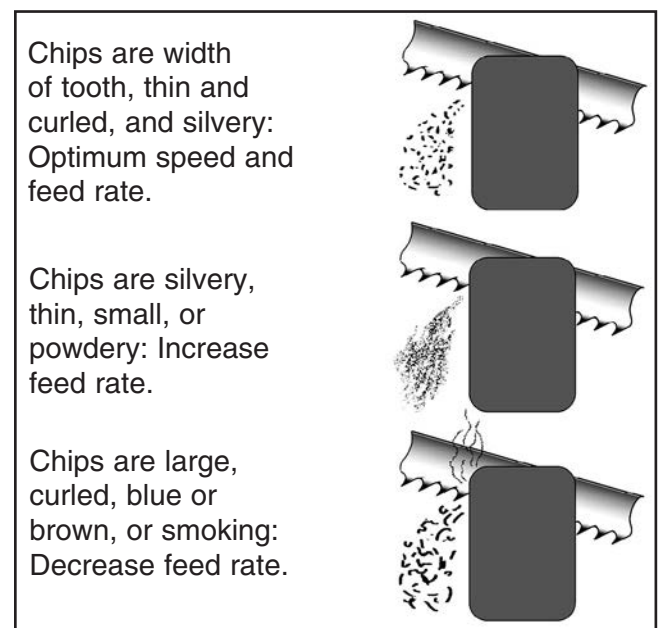

**Figure 23.** Reading chips.



# Blade Guides

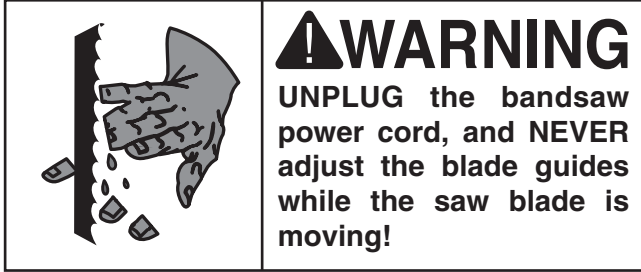

The blade guide side bearings support and twist the blade straight so the blade will enter the workpiece perpendicular to the table surface. The blade guide support bearings prevent blade twist by stopping the blade from being pushed back during a cut. Both adjustments are critical for correct saw operation (see **Figure 24**).

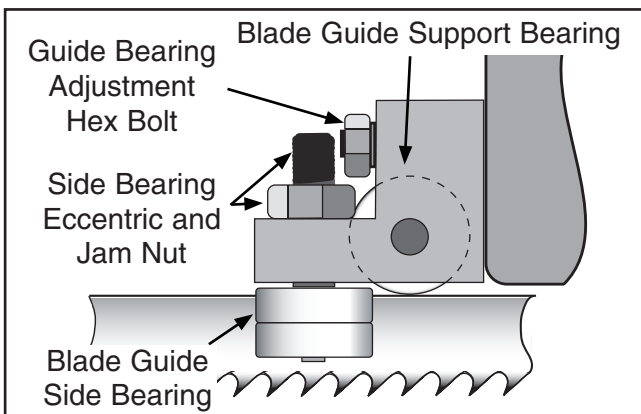
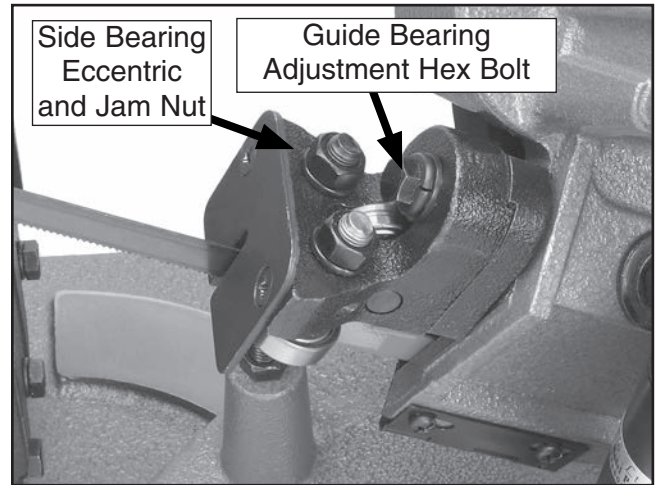

**Figure 24.** Blade guide adjustment locations.

## To adjust the guide bearings:

**Note:** Make sure the blade is tensioned and tracks correctly before you adjust the blade guide bearings. Refer to **Blade Tension** and **Blade Tracking** on **Pages 23** and **30** for further instructions.

1. UNPLUG THE BANDSAW!
2. Let the bandsaw headstock park in the full down position.
3. Using a 12mm wrench, loosen the guide bearing adjustment hex bolt (see **Figure 25**).



**Figure 25.** Blade guide adjustments.

4. Adjust the blade guide housing so the support bearing rests against the rear of the blade (see **Figure 24**).
5. Using a 14mm wrench, loosen the outer side bearing eccentric jam nuts.
6. Using a 12mm wrench, rotate the side bearing eccentrics until the bearings have a bearing-to-blade clearance of 0.000" to 0.001". The bearings must not pinch the blade and the blade needs to be perpendicular to the table.
7. Tighten the jam nuts, loosen the lock knob, and slide the blade guide close to the workpiece so the blade is supported and will not twist during the cut (see **Figure 26**).

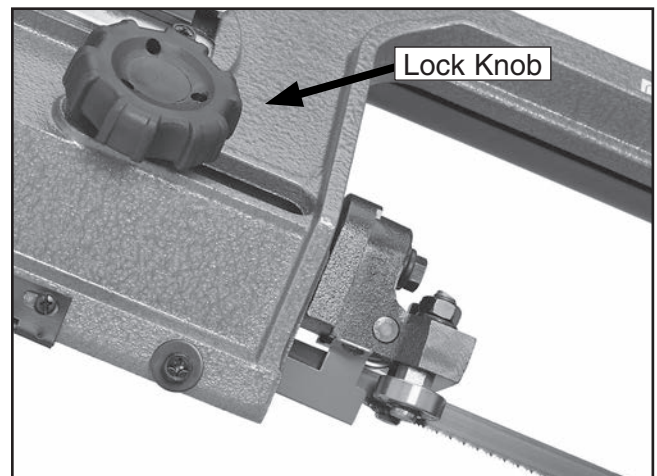

**Figure 26.** Blade guide position lock knob.



# Blade Tension

---

Proper blade tension is essential to long blade life, straight cuts, and efficient cutting.

Two major signs that you do not have proper blade tension are: 1) the blade stalls in the cut and slips on the wheels, and 2) the blade frequently breaks from being too tight.

## To tension the blade on the bandsaw:

1. Make sure the blade is tracking properly.
2. UNPLUG THE BANDSAW!
3. Slide the blade guides as far apart as they will go, then tighten them down again.
4. Turn the tension knob clockwise to tighten the blade, or counterclockwise to loosen the blade.

**Note:** To fine tune blade tension, use a blade tensioning gauge, like the one found in **SECTION 5: ACCESSORIES** on **Page 24**. Please follow the instructions included with your gauge and the blade manufacturer's recommendations on blade tension.

# Operation Tips

---

The following tips will help you safely and effectively operate your bandsaw, and help you get the maximum life out of your saw blades.

## Tips for horizontal cutting:

- Use the work stop to quickly and accurately cut multiple pieces of stock to the same length.
- Clamp the material firmly in the vise jaws to ensure a straight cut through the material, and use the positive lock to speed production.

- Let the blade reach full speed before engaging the workpiece. Never start a cut with the blade in contact with the workpiece (see **Figure 27**).
- Chips should be curled and silvery. If the chips are thin and powder like, increase your feed rate.
- Burned chips indicate a need to reduce your blade speed.
- Wait until the blade has completely stopped before removing the workpiece from the vise, and avoid touching the cut end—it could be very hot!
- Support long pieces so they won't fall when cut, and flag the end to alert passers-by of potential danger.
- Adjust the blade guides as close as possible to the workpiece to minimize side-to-side blade movement.
- Use coolant when possible to increase blade life.

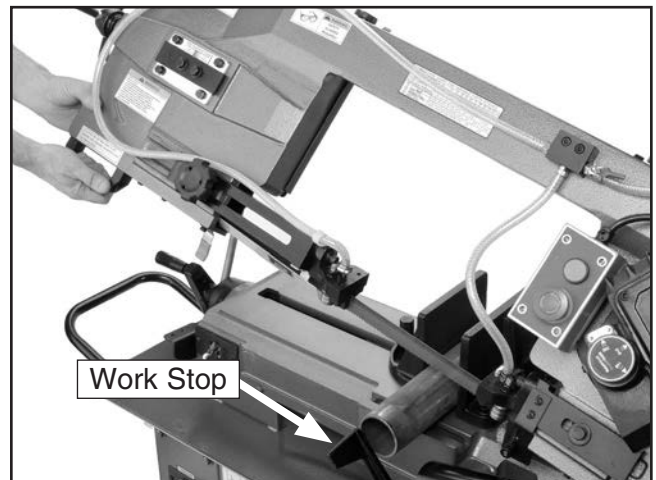

**Figure 27.** Typical proper starting position.



# SECTION 5: ACCESSORIES

- G5107—64-1/2 x 1/2 x .025 10 TPI Raker
- G5108—64-1/2 x 1/2 x .025 14 TPI Raker
- G5109—64-1/2 x 1/2 x .025 18 TPI Raker
- G5110—64-1/2 x 1/2 x .025 24 TPI Raker
- G5111—64-1/2 x 1/2 x .025 6-10 Variable Pitch
- G5112—64-1/2 x 1/2 x .025 8-12 Variable Pitch
- G5113—64-1/2x1/2 x .025 10-14 Variable Pitch
- G5114—64-1/2x1/2 x .025 14-18 Variable Pitch
- G5115—64-1/2x1/2 x .025 20-24 Variable Pitch

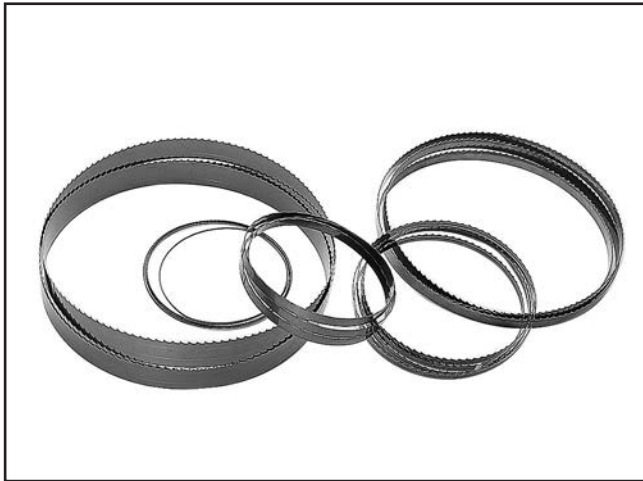

Figure 28. Blades.

## H5408—Blade Tensioning Gauge

The Blade Tensioning Gauge ensures long blade life, reduced blade breakage, and straight cutting by indicating correct tension. A precision dial indicator provides you with a direct readout in PSI.



Figure 29. H5408 blade tensioning gauge.

## Power Twist® V-Belts

### H9815—A 1/2" x 4'

A smart upgrade for any machine that uses V-belts. These link belts provide smooth running with less vibration, heat, and noise than solid belts. Power Twist® V-Belts can be customized in minutes to any size—just add or remove sections to fit your needs. Once you use a link belt, you'll like it so much you'll want to convert all your machines!

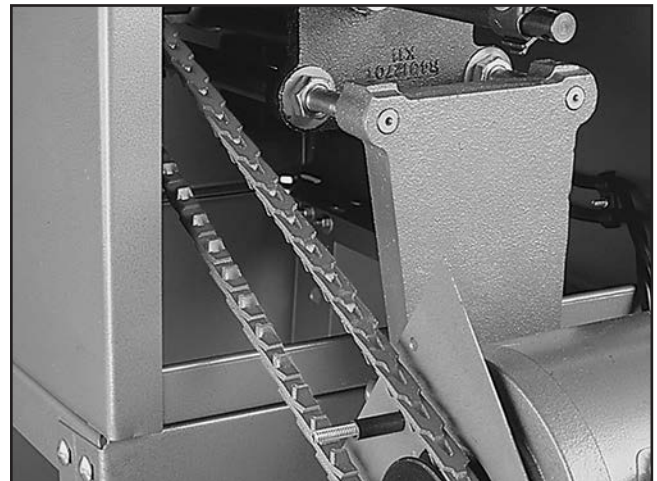

Figure 30. Power Twist® V-Belt.

## T20640—Machinery's Handbook

For more than 90 years, this handbook has been the benchmark by which machinists' and engineering texts have been judged. Includes a wealth of information on mathematics, mechanics, measurements, and materials. A must have for the amateur or professional.

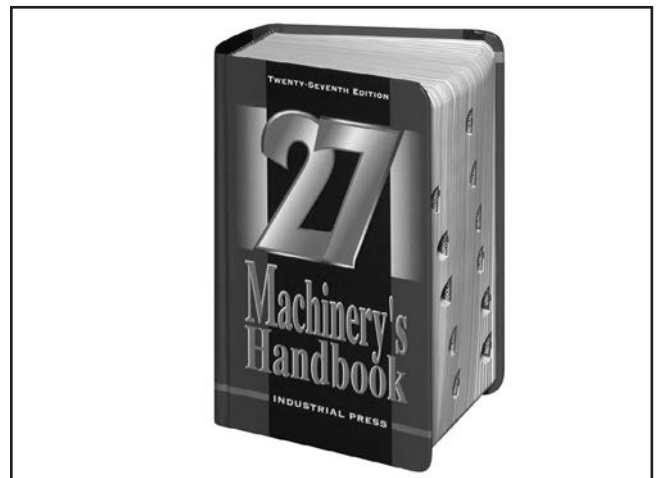

Figure 31. Machinery's Handbook.



- G5618—Deburring Tool w/ 2 Blades**
- G5619—Extra Aluminum Blades**
- G5620—Extra Brass and Cast Iron Blade**

The quickest tool for smoothing freshly machined metal edges. Comes with two blades—one for steel/aluminum and one for brass/cast iron.



**Figure 32.** G5618 deburring tool.

- G7615—Oil Can w/Steel Nozzle**
- G7616—Oil Can w/Plastic Nozzle**
- G7617—Oil Can w/Flexible Plastic Nozzle**

Whether you're lubricating cutting tools or maintaining machinery in top operating condition, you'll appreciate these High Pressure Oil Cans. Each can holds 5 ounces of oil and has a trigger activated, high pressure pump.



**Figure 34.** High pressure oil cans.

### Basic Eye Protection

- T20501—Face Shield Crown Protector 4"**
- T20502—Face Shield Crown Protector 7"**
- T20503—Face Shield Window**
- T20451—"Kirova" Clear Safety Glasses**
- T20452—"Kirova" Anti-Reflective S. Glasses**
- T20456—DAKURA Safety Glasses, Black/Clear**



**Figure 33.** Our most popular eye protection.

- G9256—6" Dial Caliper**
- G9257—8" Dial Caliper**
- G9258—12" Dial Caliper**

These traditional dial calipers are accurate to 0.001" and can measure outside surfaces, inside surfaces, and heights/depths. Features stainless steel, shock resistant construction and a dust proof display.

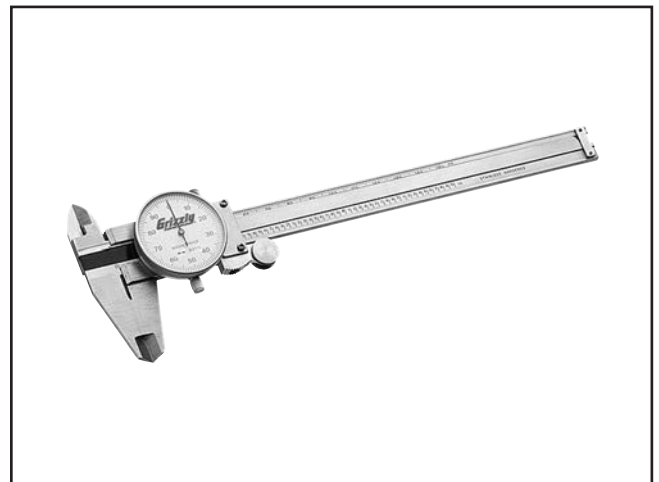
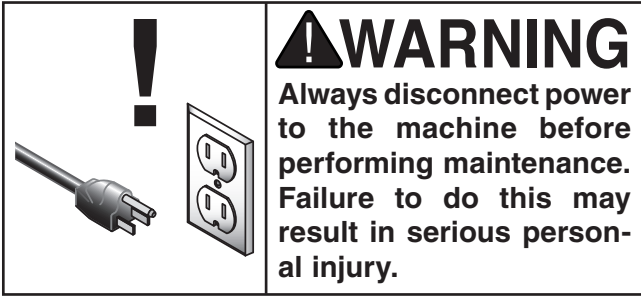

**Figure 35.** Grizzly® dial calipers.

**Call 1-800-523-4777 To Order**



# SECTION 6: MAINTENANCE



## Schedule

For optimum performance from your machine, follow this maintenance schedule and refer to any specific instructions given in this section.

### Daily Check

- Loose mounting bolts.
- Damaged saw blade.
- Worn or damaged wires.
- Any other unsafe condition.
- Clean after each use.
- Proper blade tension.

### Monthly Check

- Lubricate vise screw.
- Check V-Belt for wear.

### Annual Check

- Inspect gear lubrication.

## Cleaning

Cleaning the Model G9742 is relatively easy. Keeping metal chips away from bandsaw mechanisms is important to making sure that your bandsaw lasts a long time. Use a shop vacuum or brush off metal chips frequently.

## Lubrication

The gearbox and all bearings are sealed and permanently lubricated so no scheduled lubrication is needed. However, you must periodically lubricate adjustment locations and bare metal surfaces. Refer to **Figure 36** for lubrication points.

Lubricate the following areas listed below:

- A. Blade Tension Mechanism:** Open the main blade guard, and drop a few drops of oil on the tension knob lead screw.
- B. Blade and Guides:** Drop a few drops of light machine oil on the blade and the blade guides daily.
- C. Gear Box:** Is packed with grease and should only be changed if you suspect contamination has entered.
- D. Table and Machined Surfaces:** Keep bare metal surfaces rust-free with regular applications of products like SLIPIT®. For long term storage you may want to consider products like Boeshield T-9™.
- E. Vise Lead Screw:** Drop a few drops of light machine oil on the vise lead screw weekly.

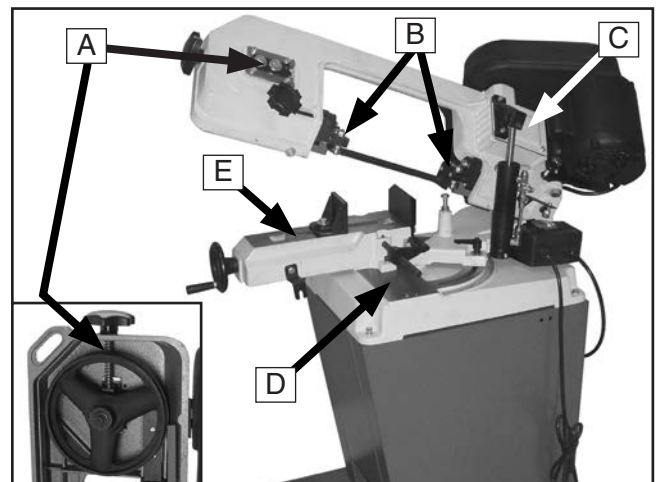

Figure 36. Lubrication points.



# SECTION 7: SERVICE

Review the troubleshooting and procedures in this section to fix your machine if a problem develops. If you need replacement parts or you are unsure of your repair skills, then feel free to call our Technical Support at (570) 546-9663.

## Troubleshooting

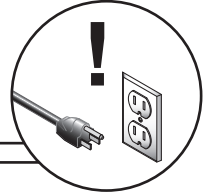

### Motor & Electrical

Symptom	Possible Cause	Possible Solution
Machine does not start or a breaker trips.	<ol style="list-style-type: none"> <li>1. Plug/receptacle is at fault or wired incorrectly.</li> <li>2. Start capacitor is at fault.</li> <li>3. Wall fuse/circuit breaker is blown/tripped.</li> <li>4. Motor connection wired incorrectly.</li> <li>5. Power supply is at fault/switched OFF.</li> <li>6. Motor ON/OFF switch is at fault.</li> <li>7. Wiring is open/has high resistance.</li> <li>8. Motor is at fault.</li> </ol>	<ol style="list-style-type: none"> <li>1. Test for good contacts; correct the wiring.</li> <li>2. Test/replace if faulty.</li> <li>3. Ensure correct size for machine load; replace weak breaker.</li> <li>4. Correct motor wiring connections.</li> <li>5. Ensure hot lines have correct voltage on all legs and main power supply is switched ON.</li> <li>6. Replace faulty ON/OFF switch.</li> <li>7. Check for broken wires or disconnected/corroded connections, and repair/replace as necessary.</li> <li>8. Test/repair/replace.</li> </ol>
Machine stalls or is underpowered.	<ol style="list-style-type: none"> <li>1. Wrong blade for the workpiece material.</li> <li>2. Wrong workpiece material.</li> <li>3. Feed rate/cutting speed too fast for task.</li> <li>4. Blade is slipping on wheels.</li> <li>5. Low power supply voltage.</li> <li>6. Motor bearings are at fault.</li> <li>7. Plug/receptacle is at fault.</li> <li>8. Motor connection is wired incorrectly.</li> <li>9. Motor has overheated.</li> <li>10. Motor is at fault.</li> </ol>	<ol style="list-style-type: none"> <li>1. Use blade with correct properties for your type of cutting.</li> <li>2. Use metal with correct properties for your type of cutting.</li> <li>3. Decrease feed rate/cutting speed.</li> <li>4. Adjust blade tracking and tension.</li> <li>5. Ensure hot lines have correct voltage on all legs.</li> <li>6. Test by rotating shaft; rotational grinding/loose shaft requires bearing replacement.</li> <li>7. Test for good contacts; correct the wiring.</li> <li>8. Correct motor wiring connections.</li> <li>9. Clean off motor, let cool, and reduce workload.</li> <li>10. Test/repair/replace.</li> </ol>
Machine has vibration or noisy operation.	<ol style="list-style-type: none"> <li>1. Motor fan is rubbing on fan cover.</li> <li>2. Blade is at fault.</li> <li>3. Gearbox is at fault.</li> <li>4. Wrong blade &amp; too slow of speed.</li> </ol>	<ol style="list-style-type: none"> <li>1. Replace dented fan cover; replace loose/damaged fan.</li> <li>2. Replace/resharpen blade.</li> <li>3. Rebuild gearbox for bad gear(s)/bearing(s).</li> <li>4. Change blade and or speed.</li> </ol>



# Bandsaw Operations

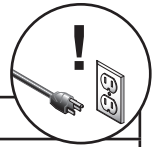

SYMPTOM	POSSIBLE CAUSE	CORRECTIVE ACTION
Machine is loud when cutting or bogs down in the cut.	<ol style="list-style-type: none"> <li>Excessive feed rate.</li> <li>The blade TPI is too great, or the material is too coarse.</li> </ol>	<ol style="list-style-type: none"> <li>Refer to <b>Feed Rate</b> on <b>Page 21</b>, or <b>Changing Blade Speed</b> on <b>Page 19</b>, and adjust as required.</li> <li>Refer to <b>Blade Selection</b> on <b>Page 20</b> and adjust as required.</li> </ol>
Blades break often.	<ol style="list-style-type: none"> <li>Blade is not tensioned correctly.</li> <li>The workpiece is loose in the vise.</li> <li>The feed or cut speed is wrong.</li> <li>The blade TPI is too great, or the material is too coarse.</li> <li>The blade is rubbing on the wheel flange.</li> <li>The bandsaw is being started with the blade resting on the workpiece.</li> <li>The guide bearings are misaligned, or the blade is rubbing on the wheel flange.</li> <li>The blade is too thick, or the blades are of low quality.</li> </ol>	<ol style="list-style-type: none"> <li>Check to see that blade is not excessively tight or too loose.</li> <li>Clamp the workpiece tighter, or use a jig to hold the workpiece.</li> <li>Refer to <b>Feed Rate</b> on <b>Page 21</b>, or <b>Changing Blade Speed</b> on <b>Page 19</b>, and adjust as required.</li> <li>Refer to <b>Blade Selection</b> on <b>Page 20</b> and adjust as required.</li> <li>Refer to <b>Blade Tracking</b> on <b>Page 30</b>, and adjust as required.</li> <li>Start bandsaw and then slowly lower the headstock by setting the feed rate.</li> <li>Refer to <b>Blade Tracking</b> on <b>Page 30</b>, or <b>Blade Guides</b> on <b>Page 22</b> and adjust as required.</li> <li>Use a higher quality blade.</li> </ol>
Blade dulls prematurely.	<ol style="list-style-type: none"> <li>The cutting speed is too fast.</li> <li>The blade TPI is too coarse.</li> <li>The blade feed pressure is too light.</li> <li>The workpiece has hard spots, welds, or scale is on the material.</li> <li>The blade is twisted.</li> <li>The blade is slipping on the wheels.</li> </ol>	<ol style="list-style-type: none"> <li>Refer to <b>Changing Blade Speed</b> on <b>Page 19</b>, and adjust as required.</li> <li>Refer to <b>Blade Selection</b> on <b>Page 20</b> and adjust as required.</li> <li>Refer to <b>Feed Rate</b> on <b>Page 21</b>, and adjust as required.</li> <li>Increase the feed pressure, and reduce the cutting speed.</li> <li>Replace the blade.</li> <li>Refer to <b>Blade Tension</b> on <b>Page 23</b>, and adjust as required.</li> </ol>
Blade wears on one side.	<ol style="list-style-type: none"> <li>The blade guides are worn or mis-adjusted.</li> <li>The blade guide slide bracket is loose.</li> <li>The wheels are out of alignment.</li> </ol>	<ol style="list-style-type: none"> <li>Refer to <b>Blade Guides</b> on <b>Page 22</b> and replace or adjust.</li> <li>Tighten the blade guide bracket.</li> <li>Refer to <b>Blade Tracking</b> on <b>Page 30</b>, and adjust as required.</li> </ol>
Teeth are ripping from the blade.	<ol style="list-style-type: none"> <li>The feed pressure is too heavy and the blade speed is too slow; or the blade TPI is too coarse for the workpiece.</li> <li>The workpiece is vibrating in the vise.</li> <li>The blade gullets are loading up with chips.</li> </ol>	<ol style="list-style-type: none"> <li>Refer to <b>Blade Selection</b> on <b>Page 20</b> and decrease the feed pressure. Refer to <b>Feed Rate</b> on <b>Page 21</b>, and adjust as required.</li> <li>Re-clamp the workpiece in the vise, and use a jig if required.</li> <li>Use a coarser-tooth blade.</li> </ol>
The cuts are crooked.	<ol style="list-style-type: none"> <li>The feed pressure is too high.</li> <li>The guide bearings are out of adjustment, or too far away from the workpiece.</li> <li>The blade tension is low.</li> <li>The blade is dull.</li> <li>The blade speed is wrong.</li> </ol>	<ol style="list-style-type: none"> <li>Refer to <b>Feed Rate</b> on <b>Page 21</b>, and adjust as required.</li> <li>Refer to <b>Blade Guides</b> on <b>Page 22</b> and replace or adjust.</li> <li>Refer to <b>Blade Tension</b> on <b>Page 23</b>, and adjust as required.</li> <li>Refer to <b>Changing the Blade</b> on <b>Page 29</b> and replace the blade.</li> <li>Refer to <b>Changing Blade Speed</b> on <b>Page 19</b>, and adjust as required.</li> </ol>



# Blade Change

Blades should be changed when they become dull, damaged, or when you are using materials that require a blade of a certain type or tooth count.

## To change the bandsaw blade:

1. UNPLUG THE BANDSAW!
2. Hold the headstock, unattach the feed cylinder by removing the cap screw, then raise the headstock to the full vertical position (see **Figure 37**).

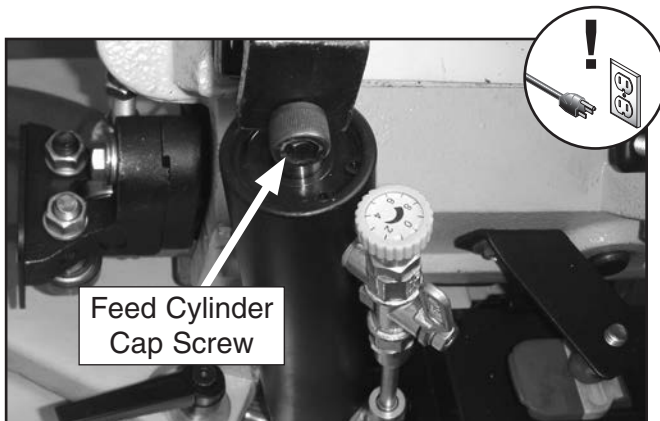

**Figure 37.** Disengaging the feed cylinder.

3. Push the safety stop in, use a screwdriver to remove the upper and lower blade guide guards, and loosen the blade guides (see **Figure 38**).

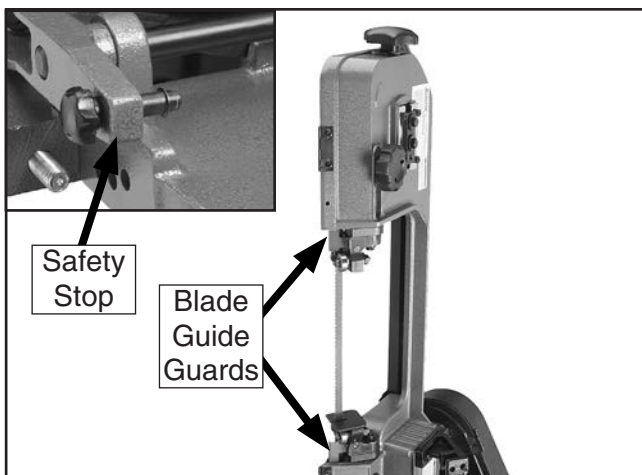

**Figure 38.** Blade guide guards and fasteners.

4. Loosen the tension knob and slip the blade off of the wheels.
5. Install the new blade through both blade guide bearings, as shown in **Figure 39**, and around the bottom wheel.



**Figure 39.** Typical blade installation.

6. Hold the blade around the bottom wheel with one hand and slip it around the top wheel with the other hand, keeping the blade between the blade guide bearings.

**Note:** It is sometimes possible to flip the blade inside out, in which case the blade will be installed in the wrong direction. Check to make sure the blade teeth are facing toward the workpiece, as shown in **Figure 39**, after mounting on the bandsaw. Some blades will have a directional arrow as a guide.

7. When the blade is around both wheels, adjust the position so the back of the blade is against the shoulder of the wheels.
8. Tighten the tension knob as tight as necessary so the blade will not slip on the wheels during start up.
9. Spin the wheel by hand until the blade resumes the previous tracking.

—If the tracking needs to be adjusted, refer to the **Tracking** procedure in the next section.

—If the tracking is fine, proceed to **Blade Tension** on **Page 23**.



10. Reinstall the blade guards, and adjust the blade guides as described in **Blade Guides** on **Page 22**
11. Re-attach the feed cylinder.

## Blade Tracking

---

The blade tracking has been properly set at the factory. The tracking will rarely need to be adjusted if the bandsaw is used properly.

### To adjust the blade tracking on the bandsaw:

1. UNPLUG THE BANDSAW!
2. Raise the headstock and lock it in place by pushing in the safety stop knob.
3. Remove both blade guide assemblies.
4. Open the wheel access cover.
5. Loosen, but do not remove the lower cap screw in the blade wheel tilting mechanism (**Figure 40**).

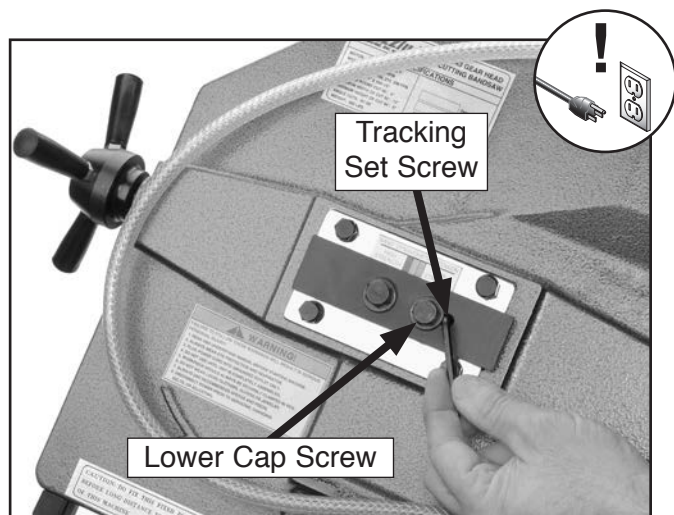

**Figure 40.** Adjusting tracking set screw.

6. Relax the blade tension.

7. Adjust the tracking set screw with a 4mm hex wrench as shown in **Figure 40**, then tighten the cap screw loosened in **Step 5**.

—Tightening the set screw will move the blade closer to the shoulder of the wheel.

—Loosening the set screw will move the blade away from the shoulder.

8. Tension the blade.
9. Spin the wheel by hand and observe how the blade tracks on the wheel.

—If the blade tracks along the shoulder of the wheel (without rubbing), the blade is tracking properly and this adjustment is completed.

—If the blade drifts away from the shoulder of the wheel or hits the shoulder, repeat **Steps 5-8**.

10. Replace the blade guard and blade guide assemblies.
11. Adjust the blade guides as needed. Refer to **Blade Guides** on **Page 22**



# Electrical Components



Figure 41. Capacitor



Figure 43. Switch wiring rear view.

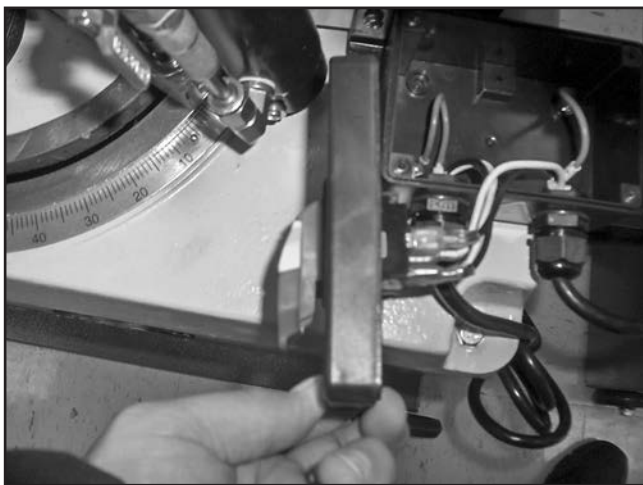

Figure 42. Switch wiring right-hand view.

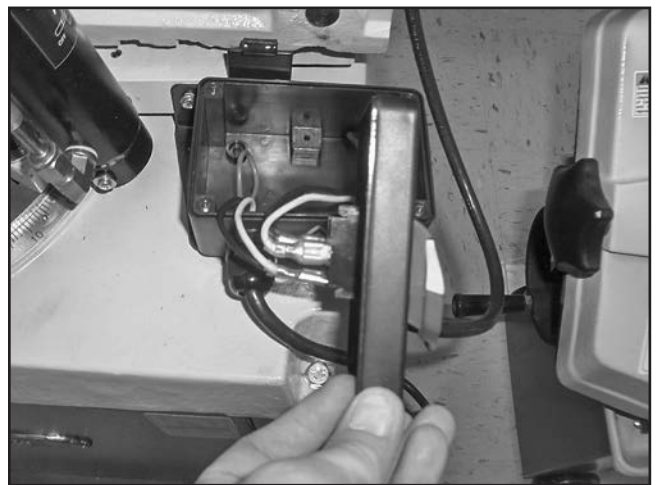
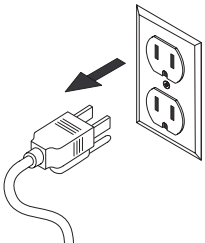

Figure 44. Switch wiring left-hand view.



# G9742 Wiring Diagram



**⚠ DANGER**

Disconnect power from machine before performing any electrical service. Failure to do this will result in a shock hazard leading to injury or death.

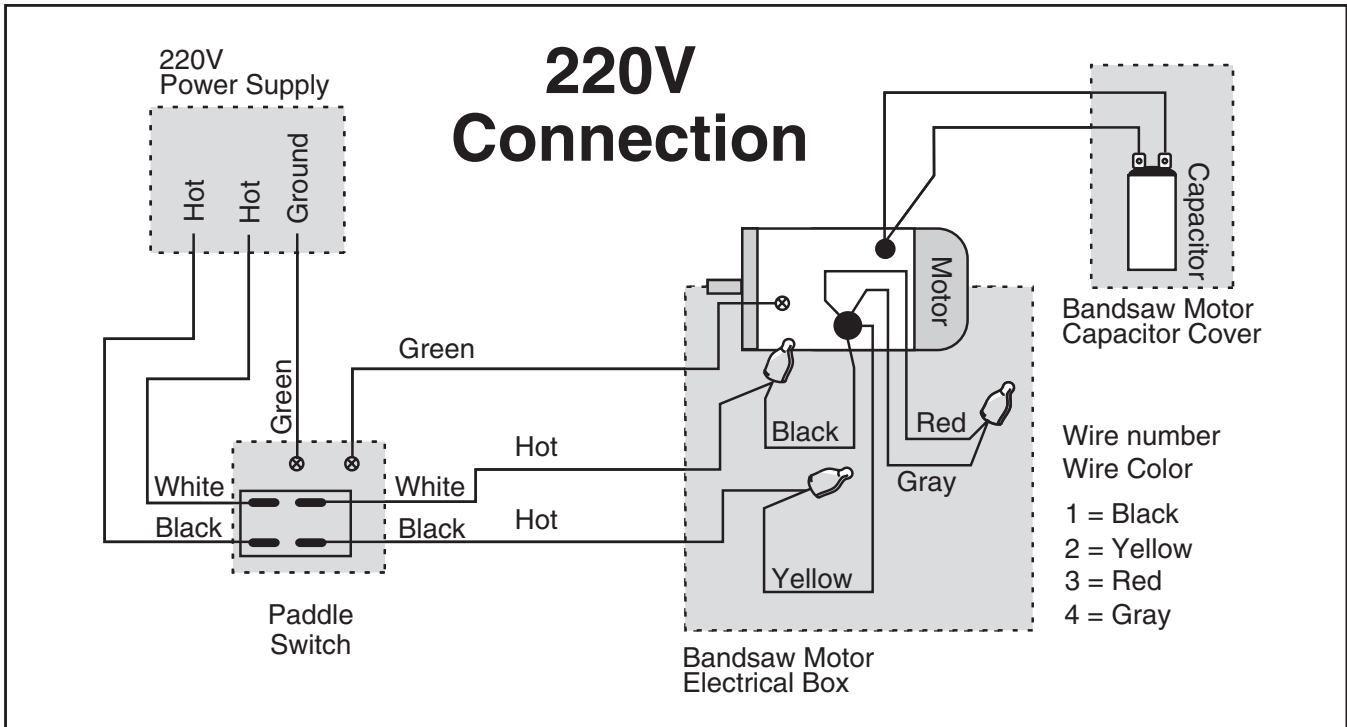
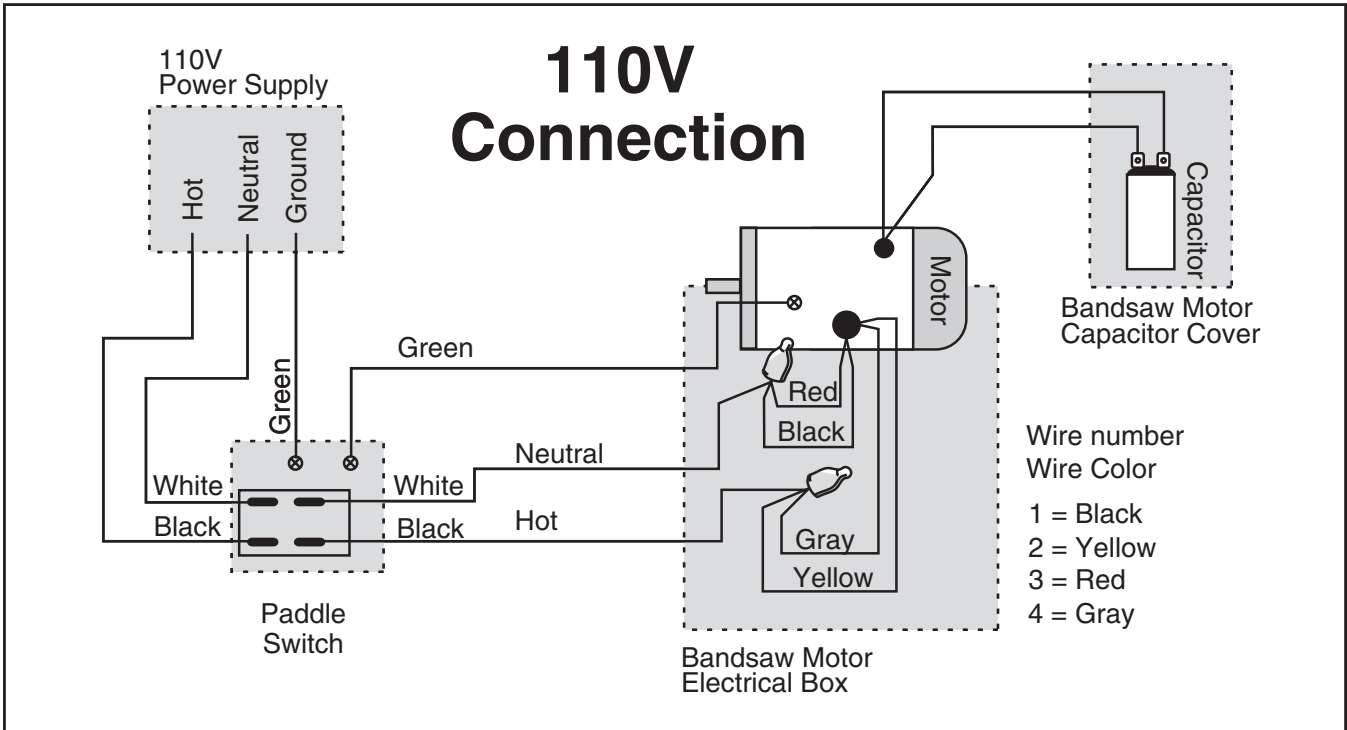



# Saw Parts List

REF	PART #	DESCRIPTION
1	P9742001	HEX BOLT 5/16-18 X 3/4
2	P9742002	HEX NUT 1/4-20
3	P9742003	FLAT WASHER 1/4
8	P9742008	FLAT WASHER 5/16
11	P9742011	HEX BOLT 5/16-18 X 1
12	P9742012	HEX NUT 5/16-18
31	P9742031	HEX BOLT 5/16-18 X 1
35	P9742035	LOCK WASHER 3/8
48	P9742048	PHLP HD SCR 10-24 X 3/8
50	P9742050	HEX BOLT 5/16-18 X 3/4
51	P9742051	FLAT WASHER 5/16
58	P9742058	KNOB 1/4-20 X 5/8
59A	P9742059A	BLADE BACK SAFETY COVER V2.11.06
66	P9742066	KNOB 3/8-16 X 1-1/4
71	P9742071	BLADE WHEEL FRONT
71-1	P9742071-1	SET SCREW 5/16-18 X 5/16
72	P9742072	BEARING COVER
73	P9742073	KEY 5 X 5 X 25
75	P9742075	HEX BOLT 1/4-20 X 5/8
76	P9742076	SWITCH CUT OFF TIP
79	P9742079	BLADE TENSION ADJ KNOB
80	P9742080	COMPRESSION SPRING
81	P9742081	BODY FRAME
83	P9742083	HEX BOLT 1/2-12 X 1-1/2
84	P9742084	MOTOR MOUNT PLATE
89	P9742089	OIL SEAL

REF	PART #	DESCRIPTION
92	P9742092	GEAR BOX GASKET
93	P9742093	COVER
97	P9742097	PHLP HD SCR M5-.8 X 12
98	P9742098	KNOB 5/16-18 X 45
100	P9742100	PHLP HD SCR 8-32 x 1/4
101	P9742101	WORM GEAR PULLEY
101-1	P9742101-1	SET SCREW 5/16-18 X 5/8
102	P9742102	LOCK WASHER 5/16
103	P9742103	BLADE TENSION SLIDING PLATE
104	P9742104	SET SCREW 5/16-18 X 5/8
108	P9742108	SHAFT BLOCK
109	P9742109	BLADE TENSION SLIDING GUIDE
112	P9742112	V-BELT A-22 4L220
113	P9742113	BLADE 64-1/2 X 1/2 X.025
120	P9742120	BUSHING 19 X 17 X 7
123	P9742123	HEX BOLT 1/4-20 X 3/4
132	P9742132	SAFETY GUARD RIGHT
133	P9742133	PHLP HD SCR 10-24 X 3/8
134	P9742134	WIRE CLAMP
182	P9742182	FLAT WASHER 5/16
198	P9742198	EXT RETAINING RING 15MM
199	P9742199	HEX BOLT 5/16-18 X 1
200	P9742200	CAP SCREW 1/4-20 X 1/2
201	P9742201	HEX NUT 5/16-18
320	P9742320	HEX BOLT 3/8-16 X 2



# Stand Parts Breakdown

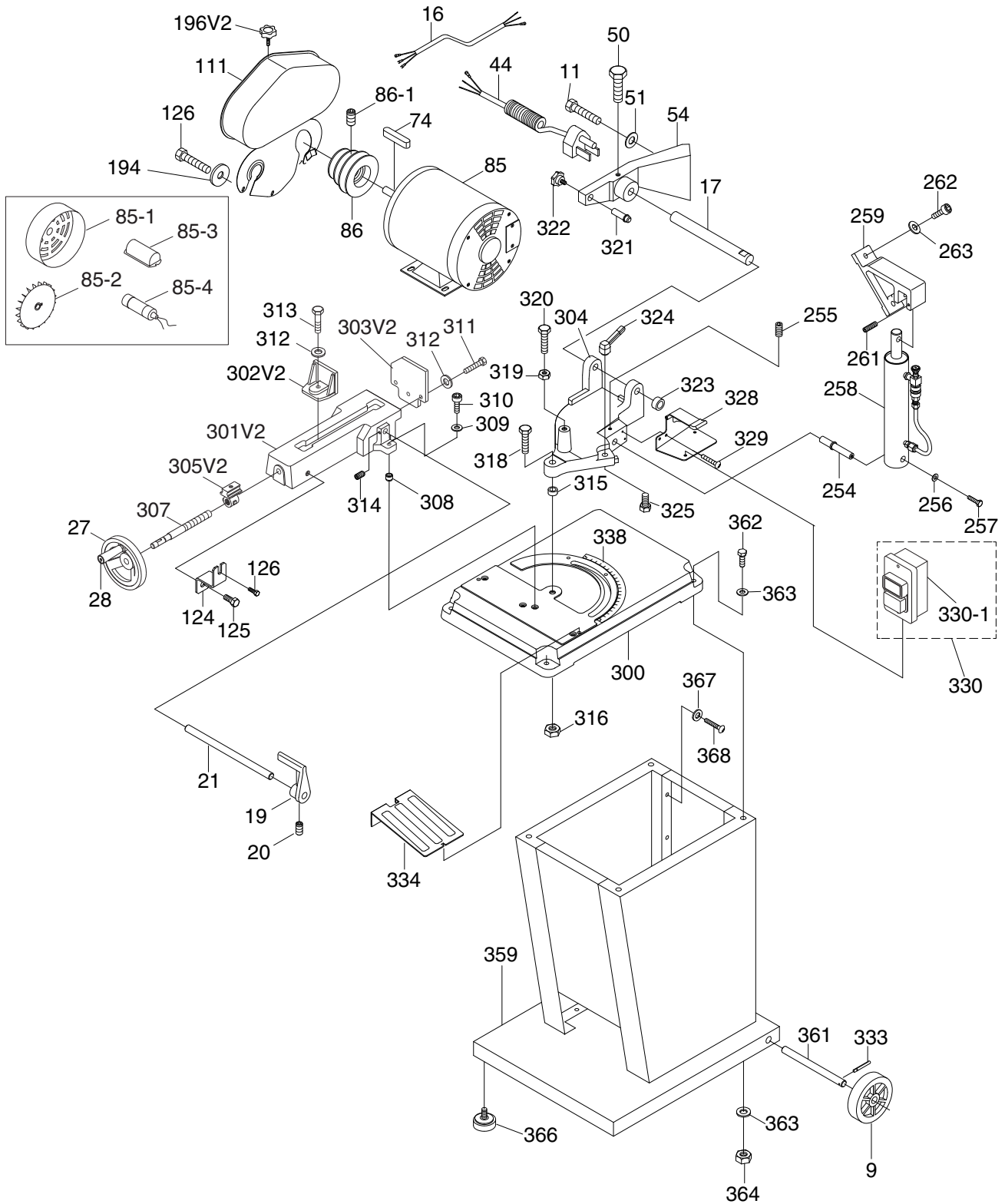

# Stand Parts List

REF	PART #	DESCRIPTION
9	P9742009	WHEEL
11	P9742011	HEX BOLT 5/16-18 X 1
16	P9742016	MOTOR CABLE
17	P9742017	PIVOTING ROD
19	P9742019	WORK STOP
20	P9742020	SET SCREW 5/16-18 X 5/16
21	P9742021	STOCK STOP ROD 1/2 X 216
27	P9742027	HANDWHEEL HANDLE
28	P9742028	HANDWHEEL
44	P9742044	POWER CABLE
50	P9742050	HEX BOLT 5/16-18 X 3/4
51	P9742051	FLAT WASHER 5/16
54	P9742054	PIVOT
74	P9742074	KEY 5 X 5 X 30
85	P9742085	MOTOR 1/2 HP
85-1	P9742085-1	MOTOR FAN COVER
85-2	P9742085-2	MOTOR FAN
85-3	P9742085-3	CAPACITOR COVER
85-4	P9742085-4	S. CAPACITOR 200MFD 125VAC
86	P9742086	MOTOR PULLEY
86-1	P9742086-1	SET SCREW 5/16-18 X 5/16
111	P9742111	PULLEY COVER ASSEMBLY
124	P9742124	SHIPPING BRACKET
125	P9742125	HEX BOLT 5/16-18 X 1/2
126	P9742126	PHLP HD SCR 1/4-20 X 1/2
194	P9742194	FENDER WASHER 1/4
196V2	P9742196V2	KNOB #8 X 3/4 V2.06.08
254	P9742254	SUPPORT ROD
255	P9742255	SET SCREW 1/4-20 X 5/16
256	P9742256	FLAT WASHER #8
257	P9742257	HEX BOLT #8-32 X 1/2
258A	P9742258A	CYLINDER ASSEMBLY V2.06.06
259	P9742259	CYLINDER UPPER SUPPORT
261	P9742261	SET SCREW #8-32 X 5/16
262	P9742262	CAP SCREW 1/4-20 X 3/4
263	P9742263	LOCK WASHER 1/4
300	P9742300	BASE
301A	P9742301A	WISE BASE V2.01.08

REF	PART #	DESCRIPTION
302A	P9742302A	WISE JAW BRACKET-FRONT V2.01.08
303A	P9742303A	VICE JAW BRACKET-REAR V2.01.08
304	P9742304	SWIVEL BASE UPPER
305A	P9742305A	BRACKET W/NUT V2.01.08
306	P9742306	ACME NUT
307A	P9742307A	ACME SCREW V2.01.08
308	P9742308	BUSHING
309	P9742309	LOCK WASHER 5/16
310	P9742310	CAP SCREW 5/16-18 X 1/2
311	P9742311	HEX BOLT 5/16-18 X 3/4
312	P9742312	LOCK WASHER 5/16
313	P9742313	HEX BOLT 5/16-18 X 1-1/4
314	P9742314	SET SCREW 1/4-20 X 3/8
315	P9742315	POSITIONING RING
316	P9742316	HEX NUT 1/2-12
318	P9742318	HEX BOLT 1/2-13 X 2-1/2
319	P9742319	HEX NUT 3/8-16
321	P9742321	POSITION PIN
322	P9742322	POSITION KNOB
323	P9742323	BUSHING
324	P9742324	HANDLE
325	P9742325	CARRIAGE BOLT 3/8-16 X 1 3/4
328	P9742328	SWITCH BASE
329	P9742329	PHLP HD SCR #10-24 X 3/8
330	P9742330	TWO-BUTTON SWITCH W/ SWITCH BOX
330-1	P9742330-1	TWO-BUTTON SWITCH
333	P9742333	COTTER PIN 3 X 25
334	P9742334	CHIP TRAY
338	P9742338	SCALE
359	P9742359	DELUXE STAND ASSEMBLY
361A	P9742361A	WHEEL ROD 21" TO 22" V2.04.04
362	P9742362	HEX BOLT M8-1.25 X 30
363	P9742363	LOCK WASHER 3/8
364	P9742364	HEX NUT M8-1.25
366	P9742366	RUBBER FOOT 3/8-16 X 1"
367	P9742367	FLAT WASHER 6MM
368	P9742368	PHLP HD SCR M6-1 X 12



# Guides & Shafts Parts Breakdown

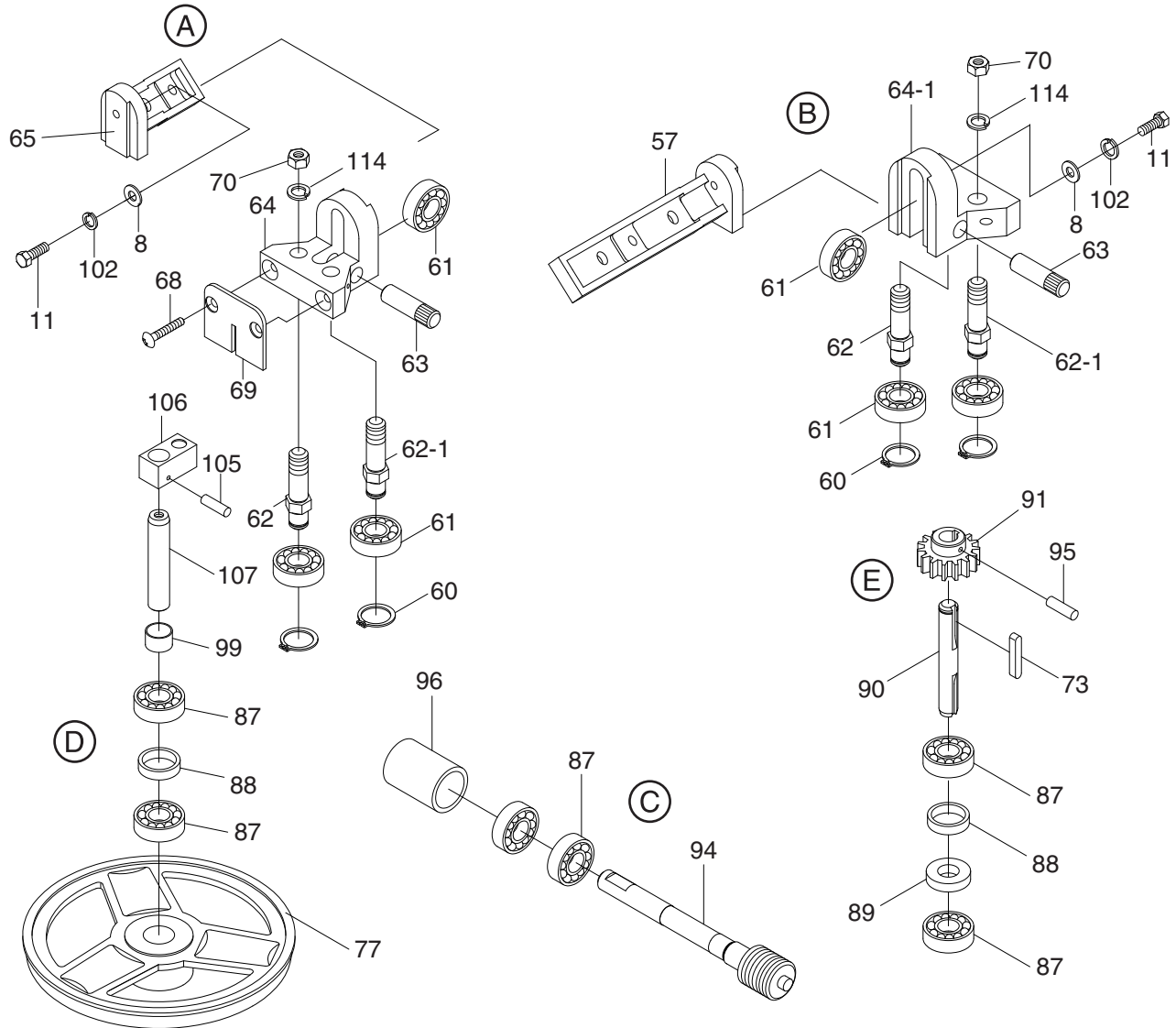

REF	PART #	DESCRIPTION
8	P9742008	FLAT WASHER 5/16
11	P9742011	HEX BOLT 5/16-18 X 1
57	P9742057	ADJUSTABLE BRACKET- LEFT
60	P9742060	EXT RETAINING RING 10MM
61	P9742061	BALL BEARING 6200ZZ
62	P9742062	GUIDE PIVOT LEFT
62-1	P9742062-1	GUIDE PIVOT RIGHT
63	P9742063	BEARING PIN
64	P9742064	BLADE GUIDE REAR
64-1	P9742064-1	BLADE GUIDE FRONT
65	P9742065	ADJUSTABLE BRACKET RIGHT
68	P9742068	FLAT HD SCR 1/4-20 X 1/2
69	P9742069	DEFLECTOR PLATE
70	P9742070	HEX NUT 3/8-16
73	P9742073	KEY 5 X 5 X 25

REF	PART #	DESCRIPTION
77	P9742077	BLADE WHEEL REAR
87	P9742087	BALL BEARING 6202ZZ
88	P9742088	BUSHING
89	P9742089	OIL SEAL
90	P9742090	TRANSMISSION WHEEL SHAFT
91	P9742091	WORM GEAR
94	P9742094	WORM GEAR SHAFT
95	P9742095	ROLL PIN 4 X 22
96	P9742096	BEARING BUSHING
99	P9742099	BUSHING
102	P9742102	LOCK WASHER 5/16
105	P9742105	ROLL PIN 4 X 20
106	P9742106	SHAFT BLOCK
107	P9742107	BLADE WHEEL SHAFT
114	P9742114	LOCK WASHER 3/8



# Labels Parts Breakdown

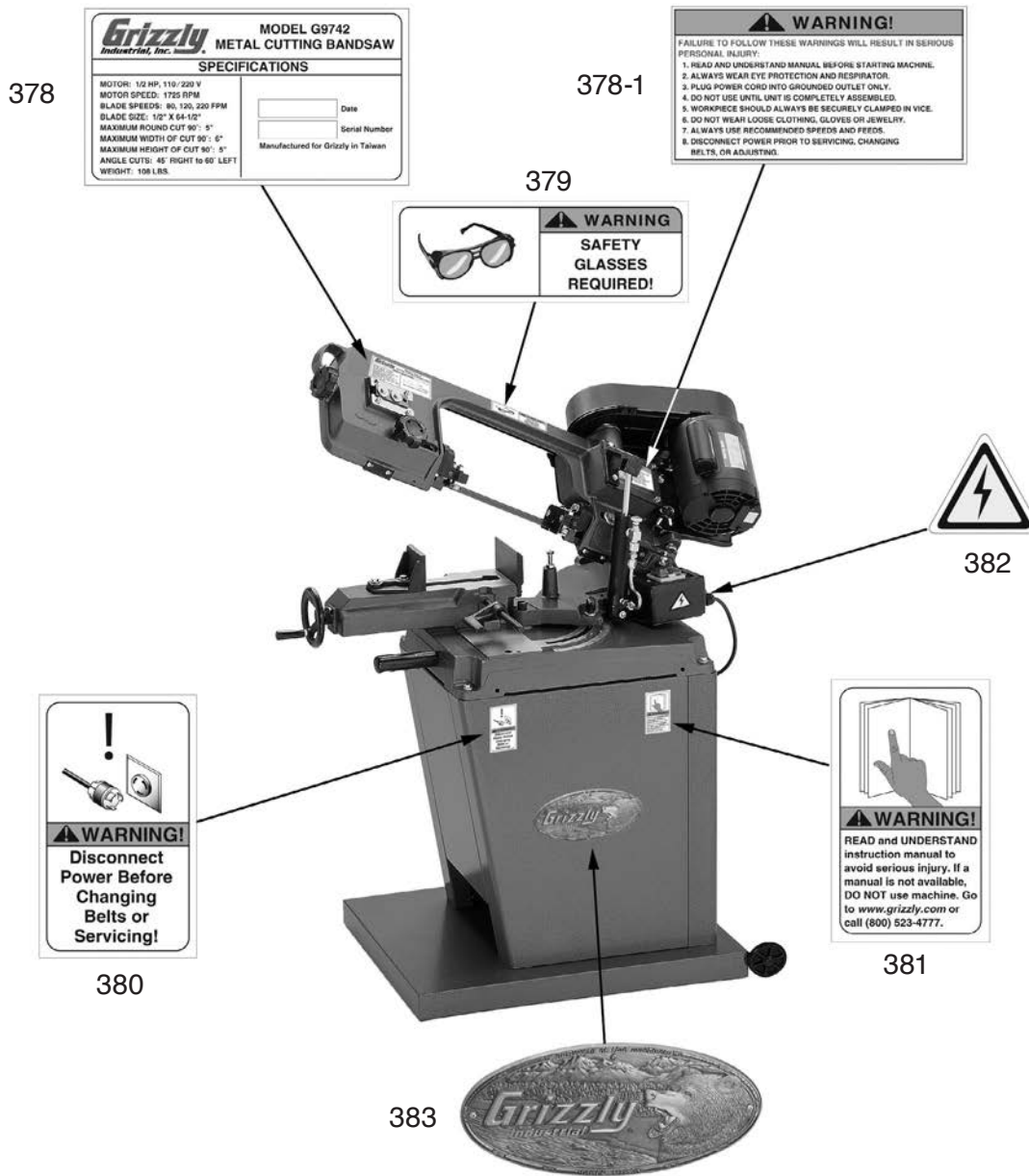

REF	PART #	DESCRIPTION
378	P9742378	MACHINE ID LABEL
378-1	P9742378-1	MACHINE WARNINGS LABEL
379	P9742379	SAFETY GLASSES LABEL
380	P9742380	UNPLUG LABEL

REF	PART #	DESCRIPTION
381	P9742381	READ MANUAL LABEL
382	P9742382	ELECTRICITY LABEL
383	P9742383	GRIZZLY LOGO PLATE

## WARNING

Safety labels warn about machine hazards and ways to prevent injury. The owner of this machine **MUST** maintain the original location and readability of the labels on the machine. If any label is removed or becomes unreadable, **REPLACE** that label before using the machine again. Contact Grizzly at (800) 523-4777 or [www.grizzly.com](http://www.grizzly.com) to order new labels.





# WARRANTY CARD

Name \_\_\_\_\_  
 Street \_\_\_\_\_  
 City \_\_\_\_\_ State \_\_\_\_\_ Zip \_\_\_\_\_  
 Phone # \_\_\_\_\_ Email \_\_\_\_\_  
 Model # \_\_\_\_\_ Order # \_\_\_\_\_ Serial # \_\_\_\_\_

The following information is given on a voluntary basis. It will be used for marketing purposes to help us develop better products and services. **Of course, all information is strictly confidential.**

- How did you learn about us?
 

<input type="checkbox"/> Advertisement	<input type="checkbox"/> Friend	<input type="checkbox"/> Catalog
<input type="checkbox"/> Card Deck	<input type="checkbox"/> Website	<input type="checkbox"/> Other:
- Which of the following magazines do you subscribe to?
 

<input type="checkbox"/> Cabinetmaker & FDM	<input type="checkbox"/> Popular Science	<input type="checkbox"/> Wooden Boat
<input type="checkbox"/> Family Handyman	<input type="checkbox"/> Popular Woodworking	<input type="checkbox"/> Woodshop News
<input type="checkbox"/> Hand Loader	<input type="checkbox"/> Precision Shooter	<input type="checkbox"/> Woodsmith
<input type="checkbox"/> Handy	<input type="checkbox"/> Projects in Metal	<input type="checkbox"/> Woodwork
<input type="checkbox"/> Home Shop Machinist	<input type="checkbox"/> RC Modeler	<input type="checkbox"/> Woodworker West
<input type="checkbox"/> Journal of Light Cont.	<input type="checkbox"/> Rifle	<input type="checkbox"/> Woodworker's Journal
<input type="checkbox"/> Live Steam	<input type="checkbox"/> Shop Notes	<input type="checkbox"/> Other:
<input type="checkbox"/> Model Airplane News	<input type="checkbox"/> Shotgun News	
<input type="checkbox"/> Old House Journal	<input type="checkbox"/> Today's Homeowner	
<input type="checkbox"/> Popular Mechanics	<input type="checkbox"/> Wood	
- What is your annual household income?
 

<input type="checkbox"/> \$20,000-\$29,000	<input type="checkbox"/> \$30,000-\$39,000	<input type="checkbox"/> \$40,000-\$49,000
<input type="checkbox"/> \$50,000-\$59,000	<input type="checkbox"/> \$60,000-\$69,000	<input type="checkbox"/> \$70,000+
- What is your age group?
 

<input type="checkbox"/> 20-29	<input type="checkbox"/> 30-39	<input type="checkbox"/> 40-49
<input type="checkbox"/> 50-59	<input type="checkbox"/> 60-69	<input type="checkbox"/> 70+
- How long have you been a woodworker/metalworker?
 

<input type="checkbox"/> 0-2 Years	<input type="checkbox"/> 2-8 Years	<input type="checkbox"/> 8-20 Years	<input type="checkbox"/> 20+ Years
------------------------------------	------------------------------------	-------------------------------------	------------------------------------
- How many of your machines or tools are Grizzly?
 

<input type="checkbox"/> 0-2	<input type="checkbox"/> 3-5	<input type="checkbox"/> 6-9	<input type="checkbox"/> 10+
------------------------------	------------------------------	------------------------------	------------------------------
- Do you think your machine represents a good value?  Yes  No
- Would you recommend Grizzly Industrial to a friend?  Yes  No
- Would you allow us to use your name as a reference for Grizzly customers in your area?  
**Note: We never use names more than 3 times.**  Yes  No

10. Comments: \_\_\_\_\_  
 \_\_\_\_\_  
 \_\_\_\_\_

CUT ALONG DOTTED LINE

FOLD ALONG DOTTED LINE

\_\_\_\_\_
\_\_\_\_\_
\_\_\_\_\_



Place Stamp Here



GRIZZLY INDUSTRIAL, INC.
P.O. BOX 2069
BELLINGHAM, WA 98227-2069



FOLD ALONG DOTTED LINE

Send a Grizzly Catalog to a friend:

Name \_\_\_\_\_
Street \_\_\_\_\_
City \_\_\_\_\_ State \_\_\_\_\_ Zip \_\_\_\_\_

TAPE ALONG EDGES--PLEASE DO NOT STAPLE

# WARRANTY AND RETURNS

---

Grizzly Industrial, Inc. warrants every product it sells for a period of **1 year** to the original purchaser from the date of purchase. This warranty does not apply to defects due directly or indirectly to misuse, abuse, negligence, accidents, repairs or alterations or lack of maintenance. This is Grizzly's sole written warranty and any and all warranties that may be implied by law, including any merchantability or fitness, for any particular purpose, are hereby limited to the duration of this written warranty. We do not warrant or represent that the merchandise complies with the provisions of any law or acts unless the manufacturer so warrants. In no event shall Grizzly's liability under this warranty exceed the purchase price paid for the product and any legal actions brought against Grizzly shall be tried in the State of Washington, County of Whatcom.

We shall in no event be liable for death, injuries to persons or property or for incidental, contingent, special, or consequential damages arising from the use of our products.

To take advantage of this warranty, contact us by mail or phone and give us all the details. We will then issue you a "Return Number," which must be clearly posted on the outside as well as the inside of the carton. We will not accept any item back without this number. Proof of purchase must accompany the merchandise.

The manufacturers reserve the right to change specifications at any time because they constantly strive to achieve better quality equipment. We make every effort to ensure that our products meet high quality and durability standards and we hope you never need to use this warranty.

Please feel free to write or call us if you have any questions about the machine or the manual.

Thank you again for your business and continued support. We hope to serve you again soon.

**grizzly.com**<sup>®</sup>  
**TOOL WEBSITE**

Buy Direct and Save with Grizzly<sup>®</sup> – Trusted, Proven and a Great Value!  
~Since 1983~

*Visit Our Website Today For  
Current Specials!*

**ORDER  
24 HOURS A DAY!  
1-800-523-4777**

