

# **Grizzly** **Industrial, Inc.**®

## **MODEL G8027** **1 HP DUST COLLECTOR** **OWNER'S MANUAL**

*(For models manufactured since 04/24)*



COPYRIGHT © MAY, 2005 BY GRIZZLY INDUSTRIAL, INC., REVISED APRIL, 2024 (KS)  
**WARNING: NO PORTION OF THIS MANUAL MAY BE REPRODUCED IN ANY SHAPE  
OR FORM WITHOUT THE WRITTEN APPROVAL OF GRIZZLY INDUSTRIAL, INC.**

#BL7091 PRINTED IN CHINA

V4.04.24

**\*\*\*Keep for Future Reference\*\*\***

 **WARNING!**

**This manual provides critical safety instructions on the proper setup, operation, maintenance, and service of this machine/tool. Save this document, refer to it often, and use it to instruct other operators.**

**Failure to read, understand and follow the instructions in this manual may result in fire or serious personal injury—including amputation, electrocution, or death.**

**The owner of this machine/tool is solely responsible for its safe use. This responsibility includes but is not limited to proper installation in a safe environment, personnel training and usage authorization, proper inspection and maintenance, manual availability and comprehension, application of safety devices, cutting/sanding/grinding tool integrity, and the usage of personal protective equipment.**

**The manufacturer will not be held liable for injury or property damage from negligence, improper training, machine modifications or misuse.**

 **WARNING!**

**Some dust created by power sanding, sawing, grinding, drilling, and other construction activities contains chemicals known to the State of California to cause cancer, birth defects or other reproductive harm. Some examples of these chemicals are:**

- **Lead from lead-based paints.**
- **Crystalline silica from bricks, cement and other masonry products.**
- **Arsenic and chromium from chemically-treated lumber.**

**Your risk from these exposures varies, depending on how often you do this type of work. To reduce your exposure to these chemicals: Work in a well ventilated area, and work with approved safety equipment, such as those dust masks that are specially designed to filter out microscopic particles.**

# Table of Contents

- INTRODUCTION..... 2**
  - Contact Info.....2
  - Manual Accuracy.....2
  - Identification.....3
  - Controls & Components.....4
  - Machine Data Sheet.....5
  
- SECTION 1: SAFETY..... 7**
  - Safety Instructions for Machinery.....7
  - Additional Safety for Dust Collectors.....9
  
- SECTION 2: POWER SUPPLY..... 10**
  
- SECTION 3: SETUP..... 12**
  - Needed for Setup.....12
  - Unpacking.....12
  - Inventory.....13
  - Hardware Recognition Chart.....14
  - Site Considerations.....15
  - Assembly.....16
  - Collection System.....19
  - Test Run.....21
  
- SECTION 4: OPERATIONS..... 22**
  - General.....22
  
- SECTION 5: ACCESSORIES..... 23**
  
- SECTION 6: MAINTENANCE..... 24**
  - Schedule.....24
  - Lubrication.....24
  - Machine Storage.....24
  - Emptying/Replacing Bags.....24
  
- SECTION 7: SERVICE..... 25**
  - Troubleshooting.....25
  - Tightening Impeller.....27
  
- SECTION 8: WIRING..... 28**
  - Wiring Safety Instructions.....28
  - Wiring Diagram.....29
  
- SECTION 9: PARTS..... 30**
  - Main.....30
  - Labels & Cosmetics.....32
  
- WARRANTY & RETURNS..... 33**

# INTRODUCTION

## Contact Info

We stand behind our machines! If you have questions or need help, contact us with the information below. Before contacting, make sure you get the **serial number** and **manufacture date** from the machine ID label. This will help us help you faster.

Grizzly Technical Support  
1815 W. Battlefield  
Springfield, MO 65807  
Phone: (570) 546-9663  
Email: techsupport@grizzly.com

We want your feedback on this manual. What did you like about it? Where could it be improved? Please take a few minutes to give us feedback.

Grizzly Documentation Manager  
P.O. Box 2069  
Bellingham, WA 98227-2069  
Email: manuals@grizzly.com

## Manual Accuracy

We are proud to provide a high-quality owner's manual with your new machine!

We made every effort to be exact with the instructions, specifications, drawings, and photographs in this manual. Sometimes we make mistakes, but our policy of continuous improvement also means that **sometimes the machine you receive is slightly different than shown in the manual.**

If you find this to be the case, and the difference between the manual and machine leaves you confused or unsure about something, check our website for an updated version. We post current manuals and manual updates for free on our website at [www.grizzly.com](http://www.grizzly.com).

Alternatively, you can call our Technical Support for help. Before calling, make sure you write down the **manufacture date** and **serial number** from the machine ID label (see below). This information is required for us to provide proper tech support, and it helps us determine if updated documentation is available for your machine.

**Grizzly Industrial** MODEL GXXXX  
MACHINE NAME

| SPECIFICATIONS       | WARNING!  |
|----------------------|---|
| Motor: _____         | To reduce risk of serious injury when using this machine: |
| Specification: _____ | 1. Read manual before operation.                          |
| Specification: _____ | 2. Wear safety glasses and respirator.                    |
| Specification: _____ | 3. Make sure machine is properly adjusted/setup and       |
| Weight: _____        | 4. Make sure the motor has stopped and disconnect         |
| Date: _____          | power before adjustments, maintenance, or service.        |
| _____                | 5. DO NOT expose to rain or dampness.                     |
| _____                | 6. DO NOT modify this machine in any way.                 |
| _____                | 7. _____  |
| _____                | 8. _____  |
| _____                | 9. _____  |
| _____                | 10. Maintain machine carefully to prevent accidents.      |

Manufactured for Grizzly in Taiwan



# Identification

Become familiar with the names and locations of the controls and features shown below to better understand the instructions in this manual.

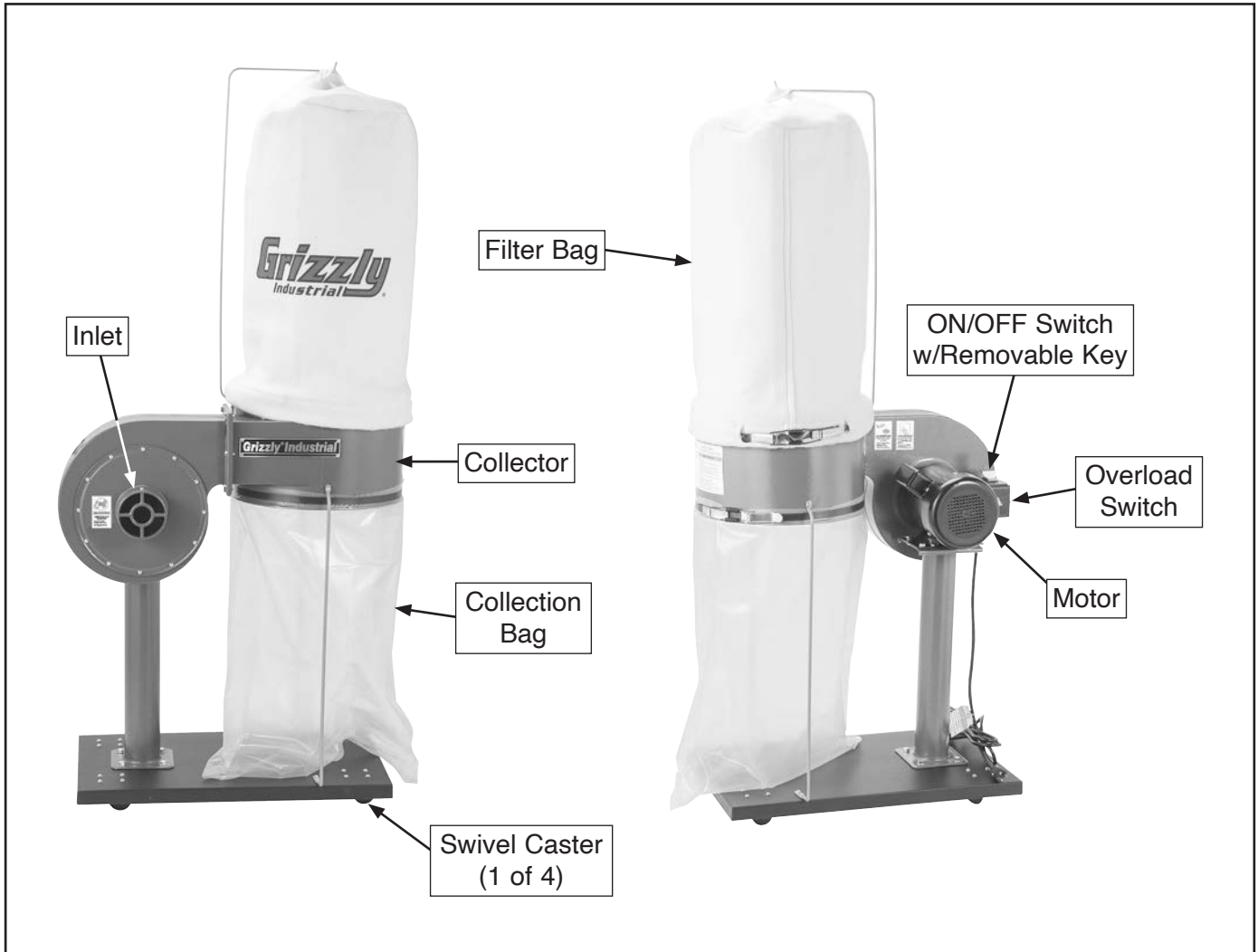

## **⚠️ WARNING**

Like all machinery there is potential danger when operating this machine. Accidents are frequently caused by lack of familiarity or failure to pay attention. Use this machine with respect and caution to decrease the risk of operator injury. If normal safety precautions are overlooked or ignored, serious personal injury may occur.

## **⚠️ CAUTION**

No list of safety guidelines can be complete. Every shop environment is different. Always consider safety first, as it applies to your individual working conditions. Use this and other machinery with caution and respect. Failure to do so could result in serious personal injury, damage to equipment, or poor work results.



# Controls & Components



Refer to the following figures and descriptions to become familiar with the basic controls and components of this machine. Understanding these items and how they work will help you understand the rest of the manual and minimize your risk of injury when operating this machine.

## Power Controls

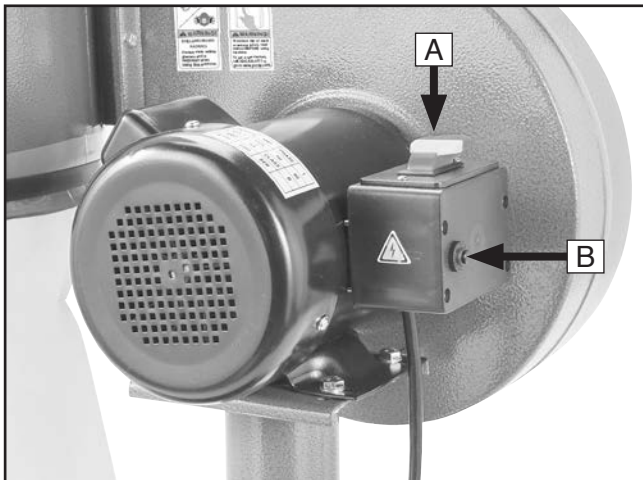

Figure 1. Power controls.

**A. ON/OFF Switch w/Removable Key:** Turns motor **ON/OFF** and prevents accidental start-up. Removal of yellow key disables switch, preventing motor from starting.

**B. Overload Switch:** Allows machine to be restarted after thermal overload protection has tripped. To reset, move ON/OFF switch to OFF position, wait a few minutes for machine to cool, then press overload switch button. If button does not *stay* depressed, allow motor to cool longer, then try again.

## Collection Components

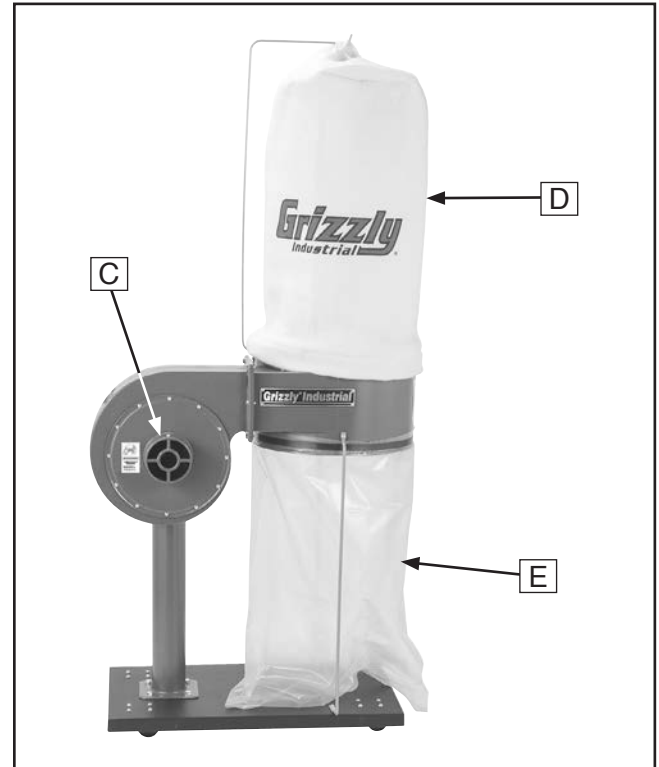

Figure 2. Collection components.

**C. Inlet:** Provides connection point for wood-working machine dust collection hose.

**D. Filter Bag:** Filters wood dust as small as 2.5 microns from collected air, and allows dust to fall and collect in lower collection bag.

**E. Collection Bag:** Collects 2.3 cubic feet of wood dust and has a quick-disconnect bag clamp for disposal.





# MACHINE DATA SHEET

Customer Service #: (570) 546-9663 · To Order Call: (800) 523-4777 · Fax #: (800) 438-5901

## MODEL G8027 1 HP DUST COLLECTOR

### Product Dimensions:

Weight..... 51 lbs.  
 Width (side-to-side) x Depth (front-to-back) x Height..... 25-1/2 x 15 x 63 in.  
 Footprint (Length x Width)..... 25-1/2 x 15 in.

### Shipping Dimensions:

Type..... Cardboard Box  
 Content..... Machine  
 Weight..... 58 lbs.  
 Length x Width x Height..... 19 x 27 x 17 in.  
 Must Ship Upright..... No

### Electrical:

Power Requirement..... 120V, Single-Phase, 60 Hz  
 Full-Load Current Rating..... 7.4A  
 Minimum Circuit Size..... 15A  
 Connection Type..... Cord & Plug  
 Power Cord Included..... Yes  
 Power Cord Length..... 10 ft.  
 Power Cord Gauge..... 16 AWG  
 Plug Included..... Yes  
 Included Plug Type..... 5-15  
 Switch Type..... Paddle Safety Switch w/Removable Key

### Motors:

#### Main

Horsepower..... 1 HP  
 Phase..... Single-Phase  
 Amps..... 7.4A  
 Speed..... 3450 RPM  
 Type..... TEFC Capacitor-Start Induction  
 Power Transfer..... Direct Drive  
 Bearings..... Sealed & Permanently Lubricated  
 Centrifugal Switch/Contacts Type..... Internal

### Main Specifications:

#### Operation

Dust Collector Type..... Single-Stage  
 Approved Dust Types..... Wood  
 Filter Type..... Bag  
 Airflow Performance..... 500 CFM  
 Max Static Pressure (at 0 CFM)..... 2.76 in.  
 Main Inlet Size..... 4 in.  
 Inlet Adapter Included..... No  
 Machine Collection Capacity At One Time..... 1  
 Maximum Material Collection Capacity..... 2.3 cu. ft.

#### Filter Information

Filtration Rating..... 2.5 Micron



**Bag Information**

Number of Upper Bags..... 1  
 Number of Lower Bags..... 1  
 Upper Bag Diameter..... 14-1/2 in.  
 Upper Bag Length..... 24 in.  
 Lower Bag Diameter..... 14-1/2 in.  
 Lower Bag Length..... 23 in.

**Impeller Information**

Impeller Type..... Radial Fin  
 Impeller Size..... 9 in.  
 Impeller Blade Thickness..... 3/32 in.

**Construction**

Upper Bag..... Fabric  
 Lower Bag..... Plastic  
 Base..... Steel Sheet Metal w/Casters  
 Frame..... Formed Steel  
 Caster..... High Density Plastic  
 Impeller..... Steel  
 Paint Type/Finish..... Powder Coated

**Other Specifications:**

Country of Origin ..... China  
 Warranty ..... 1 Year  
 Approximate Assembly & Setup Time ..... 45 Minutes  
 Serial Number Location ..... ID Label  
 Sound Rating ..... 83 dB  
 ISO 9001 Factory ..... Yes  
 Certified by a Nationally Recognized Testing Laboratory (NRTL) ..... Yes  
 Awards ..... Awarded Best Value by WOOD Magazine

**Features:**

2.5 Micron Upper Bag Filtration  
 9" Balanced Steel, Radial Fin Impeller  
 Steel Base with Casters for Mobility  
 Green Powder Coated Paint



# SECTION 1: SAFETY

## For Your Own Safety, Read Instruction Manual Before Operating This Machine

The purpose of safety symbols is to attract your attention to possible hazardous conditions. This manual uses a series of symbols and signal words intended to convey the level of importance of the safety messages. The progression of symbols is described below. Remember that safety messages by themselves do not eliminate danger and are not a substitute for proper accident prevention measures. Always use common sense and good judgment.



Indicates an imminently hazardous situation which, if not avoided, **WILL** result in death or serious injury.



Indicates a potentially hazardous situation which, if not avoided, **COULD** result in death or serious injury.



Indicates a potentially hazardous situation which, if not avoided, **MAY** result in minor or moderate injury. It may also be used to alert against unsafe practices.

**NOTICE**

Alerts the user to useful information about proper operation of the machine to avoid machine damage.

## Safety Instructions for Machinery

### **WARNING**

**OWNER'S MANUAL.** Read and understand this owner's manual **BEFORE** using machine.

**TRAINED OPERATORS ONLY.** Untrained operators have a higher risk of being hurt or killed. Only allow trained/supervised people to use this machine. When machine is not being used, disconnect power, remove switch keys, or lock-out machine to prevent unauthorized use—especially around children. Make your workshop kid proof!

**DANGEROUS ENVIRONMENTS.** Do not use machinery in areas that are wet, cluttered, or have poor lighting. Operating machinery in these areas greatly increases the risk of accidents and injury.

**MENTAL ALERTNESS REQUIRED.** Full mental alertness is required for safe operation of machinery. Never operate under the influence of drugs or alcohol, when tired, or when distracted.

#### **ELECTRICAL EQUIPMENT INJURY RISKS.**

You can be shocked, burned, or killed by touching live electrical components or improperly grounded machinery. To reduce this risk, only allow qualified service personnel to do electrical installation or repair work, and always disconnect power before accessing or exposing electrical equipment.

**DISCONNECT POWER FIRST.** Always disconnect machine from power supply **BEFORE** making adjustments, changing tooling, or servicing machine. This prevents an injury risk from unintended startup or contact with live electrical components.

**EYE PROTECTION.** Always wear ANSI-approved safety glasses or a face shield when operating or observing machinery to reduce the risk of eye injury or blindness from flying particles. Everyday eyeglasses are **NOT** approved safety glasses.



## **WARNING**

**WEARING PROPER APPAREL.** Do not wear loose clothing, gloves, neckties, or jewelry that can become entangled in moving parts. Always tie back or cover long hair. Wear non-slip footwear to reduce risk of slipping and losing control or accidentally contacting cutting tool or moving parts.

**HAZARDOUS DUST.** Dust created by machinery operations may cause cancer, birth defects, or long-term respiratory damage. Be aware of dust hazards associated with each workpiece material. Always wear a NIOSH-approved respirator to reduce your risk.

**HEARING PROTECTION.** Always wear hearing protection when operating or observing loud machinery. Extended exposure to this noise without hearing protection can cause permanent hearing loss.

**REMOVE ADJUSTING TOOLS.** Tools left on machinery can become dangerous projectiles upon startup. Never leave chuck keys, wrenches, or any other tools on machine. Always verify removal before starting!

**USE CORRECT TOOL FOR THE JOB.** Only use this tool for its intended purpose—do not force it or an attachment to do a job for which it was not designed. Never make unapproved modifications—modifying tool or using it differently than intended may result in malfunction or mechanical failure that can lead to personal injury or death!

**AWKWARD POSITIONS.** Keep proper footing and balance at all times when operating machine. Do not overreach! Avoid awkward hand positions that make workpiece control difficult or increase the risk of accidental injury.

**CHILDREN & BYSTANDERS.** Keep children and bystanders at a safe distance from the work area. Stop using machine if they become a distraction.

**GUARDS & COVERS.** Guards and covers reduce accidental contact with moving parts or flying debris. Make sure they are properly installed, undamaged, and working correctly **BEFORE** operating machine.

**FORCING MACHINERY.** Do not force machine. It will do the job safer and better at the rate for which it was designed.

**NEVER STAND ON MACHINE.** Serious injury may occur if machine is tipped or if the cutting tool is unintentionally contacted.

**STABLE MACHINE.** Unexpected movement during operation greatly increases risk of injury or loss of control. Before starting, verify machine is stable and mobile base (if used) is locked.

**USE RECOMMENDED ACCESSORIES.** Consult this owner's manual or the manufacturer for recommended accessories. Using improper accessories will increase the risk of serious injury.

**UNATTENDED OPERATION.** To reduce the risk of accidental injury, turn machine **OFF** and ensure all moving parts completely stop before walking away. Never leave machine running while unattended.

**MAINTAIN WITH CARE.** Follow all maintenance instructions and lubrication schedules to keep machine in good working condition. A machine that is improperly maintained could malfunction, leading to serious personal injury or death.

**DAMAGED PARTS.** Regularly inspect machine for damaged, loose, or mis-adjusted parts—or any condition that could affect safe operation. Immediately repair/replace **BEFORE** operating machine. For your own safety, **DO NOT** operate machine with damaged parts!

**MAINTAIN POWER CORDS.** When disconnecting cord-connected machines from power, grab and pull the plug—**NOT** the cord. Pulling the cord may damage the wires inside. Do not handle cord/plug with wet hands. Avoid cord damage by keeping it away from heated surfaces, high traffic areas, harsh chemicals, and wet/damp locations.

**EXPERIENCING DIFFICULTIES.** If at any time you experience difficulties performing the intended operation, stop using the machine! Contact our Technical Support at (570) 546-9663.



# Additional Safety for Dust Collectors

## **WARNING**

Long-term respiratory damage can occur from using dust collectors without proper use of a respirator. Fire or explosions can result in smoke inhalation, serious burns, or death—if machine is used to collect incorrect materials, is operated near potential explosion sources, or ducting is improperly grounded. Entanglement, amputation, or death can occur if hair, clothing, or fingers are pulled into the inlet. To reduce the risk of these hazards, operator and bystanders **MUST** completely heed the hazards and warnings below.

**INTENDED USE.** Collecting the wrong materials can result in serious inhalation hazards, fire, explosions, or machine damage. This machine is **ONLY** designed to collect wood dust and chips from woodworking machines. **DO NOT** use it to collect silica, polyurethane, toxic fumes, metal dust or shavings, lead paint, drywall, asbestos, biohazards, explosive dusts, flammable or combustible liquids or fumes, nor burning or smoking material.

**WEAR A RESPIRATOR.** Fine dust that is too small to be caught in filter will be blown into ambient air. Always wear a NIOSH-approved respirator during operation and for a short time after to reduce your risk of permanent respiratory damage. Never collect dust from any hazardous material.

**IMPELLER HAZARDS.** To reduce risk of entanglement or contact with impeller, **DO NOT** place hands, hair, clothing, or tools in or near open dust collection inlet during operation, and keep small animals and children away. The powerful suction could easily pull them into impeller.

**HAZARDOUS DUST.** Dust exposure created while using machinery may cause cancer, birth defects, or long-term respiratory damage. Be aware of dust hazards associated with each workpiece material, and always wear a NIOSH-approved respirator.

**EMPTYING DUST.** When emptying bag or drum, wear respirator and safety glasses. Empty dust away from ignition sources and into approved container.

**OPERATING LOCATION.** To reduce respiratory exposure to fine dust, locate permanently installed dust collectors away from working area or in another room. **DO NOT** place dust collector where it can be exposed to rain or moisture, which creates a shock hazard and will reduce life of machine.

**POWER DISCONNECT.** Turn machine **OFF**, disconnect from power supply, and allow impeller to completely stop before leaving machine unattended, or doing any maintenance or service.

**REGULAR CLEANING.** To reduce risk of starting a fire, regularly check/empty collection bags or drum to avoid buildup of fine dust, which can increase risk of fire. Regularly clean surrounding area where machine is operated—excessive dust buildup on overhead lights, heaters, electrical panels, or other heat sources will increase risk of fire.

**SUSPENDED DUST PARTICLES.** To reduce risk of death or injury caused by explosions or fires, **DO NOT** operate in areas where these risks are high, including spaces near pilot lights, open flames, or other ignition sources.

**AVOIDING SPARKS.** To reduce risk of fire, avoid collecting any metal objects or stones. These can possibly produce sparks when they strike impeller, which can smolder in wood dust for a long time before a fire is detected. If you accidentally cut into wood containing metal, immediately turn **OFF** dust collector, disconnect from power, and wait for impeller to stop. Then empty bag or drum into approved airtight metal container.

**FIRE SUPPRESSION.** Only operate dust collector in locations that contain fire suppression system or have fire extinguisher nearby.

**STATIC ELECTRICITY.** To reduce risk of fire or explosions caused by sparks from static electricity, ground all ducting using grounding wire.

**DUST ALLERGIES.** Dust from certain woods will cause an allergic reaction. Make sure you know what type of wood dust you will be exposed to in case of an allergic reaction.



# SECTION 2: POWER SUPPLY

## Availability

Before installing the machine, consider the availability and proximity of the required power supply circuit. If an existing circuit does not meet the requirements for this machine, a new circuit must be installed. To minimize the risk of electrocution, fire, or equipment damage, installation work and electrical wiring must be done by an electrician or qualified service personnel in accordance with all applicable codes and standards.

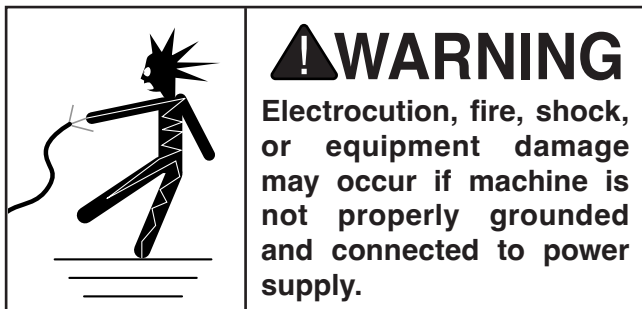

## Full-Load Current Rating

The full-load current rating is the amperage a machine draws at 100% of the rated output power. On machines with multiple motors, this is the amperage drawn by the largest motor or sum of all motors and electrical devices that might operate at one time during normal operations.

### Full-Load Current Rating at 120V .... 7.4 Amps

The full-load current is not the maximum amount of amps that the machine will draw. If the machine is overloaded, it will draw additional amps beyond the full-load rating.

If the machine is overloaded for a sufficient length of time, damage, overheating, or fire may result—especially if connected to an undersized circuit. To reduce the risk of these hazards, avoid overloading the machine during operation and make sure it is connected to a power supply circuit that meets the specified circuit requirements.

## **! WARNING**

**Serious injury could occur if you connect machine to power before completing setup process. DO NOT connect to power until instructed later in this manual.**

## 120V Circuit Requirements

This machine is prewired to operate on a power supply circuit that has a verified ground and meets the following requirements:

Nominal Voltage ..... 110V, 115V, 120V  
Cycle ..... 60 Hz  
Phase ..... Single-Phase  
Power Supply Circuit ..... 15 Amps  
Plug/Receptacle ..... NEMA 5-15

A power supply circuit includes all electrical equipment between the breaker box or fuse panel in the building and the machine. The power supply circuit used for this machine must be sized to safely handle the full-load current drawn from the machine for an extended period of time. (If this machine is connected to a circuit protected by fuses, use a time delay fuse marked D.)

## **! CAUTION**

**For your own safety and protection of property, consult an electrician if you are unsure about wiring practices or electrical codes in your area.**

**Note:** *Circuit requirements in this manual apply to a dedicated circuit—where only one machine will be running on the circuit at a time. If machine will be connected to a shared circuit where multiple machines may be running at the same time, consult an electrician or qualified service personnel to ensure circuit is properly sized for safe operation.*



## Grounding & Plug Requirements

This machine **MUST** be grounded. In the event of certain malfunctions or breakdowns, grounding reduces the risk of electric shock by providing a path of least resistance for electric current.

This machine is equipped with a power cord that has an equipment-grounding wire and a grounding plug. Only insert plug into a matching receptacle (outlet) that is properly installed and grounded in accordance with all local codes and ordinances. **DO NOT** modify the provided plug!

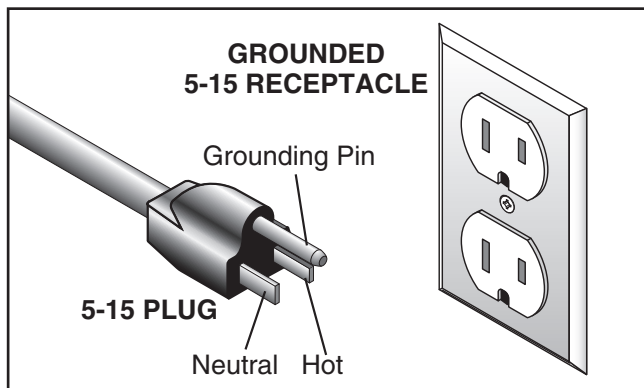

Figure 3. Typical 5-15 plug and receptacle.

**⚠ CAUTION**

The image shows three circular icons, each with a large 'X' over it, indicating that these practices are unsafe and prohibited. From left to right: 1) A two-prong plug. 2) A modified plug with a ground wire attached to one of the prongs. 3) A two-prong outlet.

**SHOCK HAZARD!**

**Two-prong outlets do not meet the grounding requirements for this machine. Do not modify or use an adapter on the plug provided—if it will not fit the outlet, have a qualified electrician install the proper outlet with a verified ground.**

Improper connection of the equipment-grounding wire can result in a risk of electric shock. The wire with green insulation (with or without yellow stripes) is the equipment-grounding wire. If repair or replacement of the power cord or plug is necessary, do not connect the equipment-grounding wire to a live (current carrying) terminal.

Check with a qualified electrician or service personnel if you do not understand these grounding requirements, or if you are in doubt about whether the tool is properly grounded. If you ever notice that a cord or plug is damaged or worn, disconnect it from power, and immediately replace it with a new one.

## Extension Cords

We do not recommend using an extension cord with this machine. If you must use an extension cord, only use it if absolutely necessary and only on a temporary basis.

Extension cords cause voltage drop, which can damage electrical components and shorten motor life. Voltage drop increases as the extension cord size gets longer and the gauge size gets smaller (higher gauge numbers indicate smaller sizes).

Any extension cord used with this machine must be in good condition and contain a ground wire and matching plug/receptacle. Additionally, it must meet the following size requirements:

**Minimum Gauge Size .....16 AWG**  
**Maximum Length (Shorter is Better).....50 ft.**



# SECTION 3: SETUP

---

---

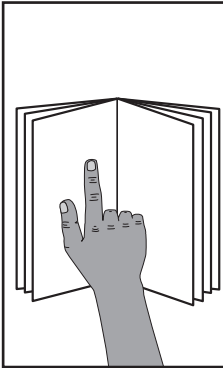

## **!WARNING**

This machine presents serious injury hazards to untrained users. Read through this entire manual to become familiar with the controls and operations before starting the machine!

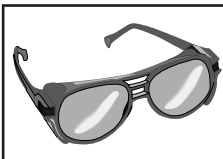

## **!WARNING**

Wear safety glasses during the entire setup process!

## Needed for Setup

---

---

The following items are needed, but not included, for the setup/assembly of this machine.

| Description                             | Qty   |
|---|-------|
| • Safety Glasses (for each person)..... | 1 Pr. |
| • Phillips Head Screwdriver #2 .....    | 1     |
| • Wrench or Socket 8mm.....             | 1     |
| • Wrenches or Sockets 13mm .....        | 2     |
| • Open-End Wrenches 10mm.....           | 2     |

## Unpacking

---

---

This machine was carefully packaged for safe transport. When unpacking, separate all enclosed items from packaging materials and inspect them for shipping damage. ***If items are damaged, please call us immediately at (570) 546-9663.***

**IMPORTANT:** Save all packaging materials until you are completely satisfied with the machine and have resolved any issues between Grizzly or the shipping agent. *You MUST have the original packaging to file a freight claim. It is also extremely helpful if you need to return your machine later.*



# Inventory

The following is a list of items shipped with your machine. Before beginning setup, lay these items out and inventory them.

If any non-proprietary parts are missing (e.g. a nut or a washer), we will gladly replace them; or for the sake of expediency, replacements can be obtained at your local hardware store.

## NOTICE

If you cannot find an item on this list, carefully check around/inside the machine and packaging materials. Often, these items get lost in packaging materials while unpacking or they are pre-installed at the factory.

| Box Components (Figure 4)              | Qty |
|--|-----|
| A. Motor/Impeller Housing .....        | 1   |
| B. Collector .....                     | 1   |
| C. Column & Motor Plate Assembly ..... | 1   |
| D. Base Plate .....                    | 1   |
| E. Bags .....                          | 2   |
| F. Rubber Gasket .....                 | 1   |
| G. Swivel Casters.....                 | 4   |
| H. Collection Bag Support Rods.....    | 2   |
| I. Upper Bag Support Rod.....          | 1   |
| J. Bag Clamps.....                     | 2   |
| K. Hardware and Tools (Not Shown)      |     |
| —Hex Bolts M6-1 x 15 .....             | 6   |
| —Hex Bolts M8-1.25 x 15.....           | 8   |
| —Hex Nuts M8-1.25 .....                | 4   |
| —Hex Nuts M5-.8.....                   | 18  |
| —Flat Washers 8mm.....                 | 12  |
| —Flat Washers 5mm.....                 | 22  |
| —Phillips Head Screws M5-.8 x 15 ..... | 6   |
| —Phillips Head Screws M5-.8 x 10 ..... | 16  |
| —Phillips Head Screws M4-.7 x 8 .....  | 2   |
| —Hex Wrench 5mm .....                  | 1   |

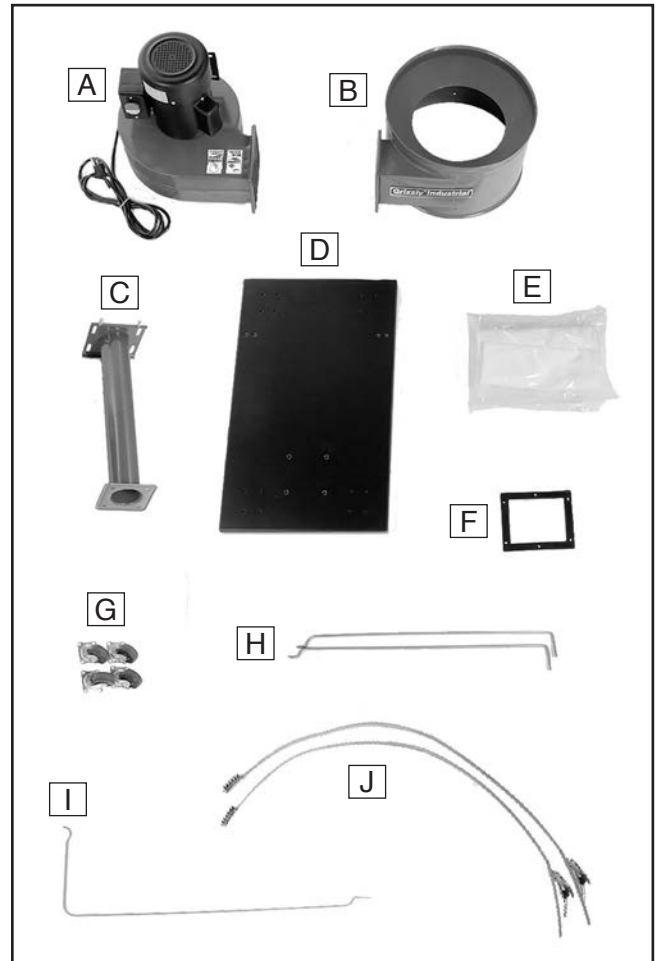

Figure 4. Main box inventory.



# Hardware Recognition Chart

USE THIS CHART TO MATCH UP HARDWARE DURING THE INVENTORY AND ASSEMBLY PROCESS.

**MEASURE BOLT DIAMETER BY PLACING INSIDE CIRCLE**

#10  
1/4"  
5/16"  
3/8"  
7/16"  
1/2"

Hex Wrench  
Phillips Head Screw  
Flat Head Screw  
Flat Head Cap Screw  
Cap Screw  
Carriage Bolt  
Flange Bolt  
Button Head Screw  
Tap Screw  
Set Screw  
Hex Bolt

Lock Nut  
Wing Nut

WASHER DIAMETER 5/8"  
WASHER DIAMETER 9/16"  
WASHER DIAMETER 1/2"  
WASHER DIAMETER 7/16"  
WASHER DIAMETER 12mm  
WASHER DIAMETER 3/8"  
WASHER DIAMETER 4mm  
WASHER DIAMETER 5/16"  
WASHER DIAMETER 10mm  
WASHER DIAMETER 5mm  
WASHER DIAMETER 1/4"  
WASHER DIAMETER 8mm  
WASHER DIAMETER 6mm  
#10

**MEASURE BOLT DIAMETER BY PLACING INSIDE CIRCLE**

4mm  
5mm  
6mm  
8mm  
10mm  
12mm  
16mm

Key  
Flat Washer  
Lock Washer  
Hex Nut

External Retaining Ring  
Internal Retaining Ring  
E-Clip

5mm  
10mm  
15mm  
20mm  
25mm  
30mm  
35mm  
40mm  
45mm  
50mm  
55mm  
60mm  
65mm  
70mm  
75mm

1/4"  
3/8"  
1/2"  
5/8"

5/16"  
7/16"  
9/16"  
3/4"  
7/8"  
1"  
1 1/4"  
1 1/2"  
1 3/4"  
2  
2 1/4"  
2 1/2"  
2 3/4"  
3

**WASHERS ARE MEASURED BY THE INSIDE DIAMETER**

WASHER DIAMETER 12mm  
WASHER DIAMETER 10mm  
WASHER DIAMETER 8mm



# Site Considerations

## Weight Load

Refer to the **Machine Data Sheet** for the weight of your machine. Make sure that the surface upon which the machine is placed will bear the weight of the machine, additional equipment that may be installed on the machine, and the heaviest workpiece that will be used. Additionally, consider the weight of the operator and any dynamic loading that may occur when operating the machine.

## Space Allocation

Consider the largest size of workpiece that will be processed through this machine and provide enough space around the machine for adequate operator material handling or the installation of auxiliary equipment. With permanent installations, leave enough space around the machine to open or remove doors/covers as required by the maintenance and service described in this manual. **See below for required space allocation.**

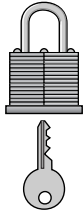
|   |  |
|---|--|
|  | <p><b>CAUTION</b></p> <p>Children or untrained people may be seriously injured by this machine. Only install in an access restricted location.</p> |
|---|--|

## Physical Environment

The physical environment where the machine is operated is important for safe operation and longevity of machine components. For best results, operate this machine in a dry environment that is free from excessive moisture, hazardous chemicals, airborne abrasives, or extreme conditions. Extreme conditions for this type of machinery are generally those where the ambient temperature range exceeds 41°–104°F; the relative humidity range exceeds 20%–95% (non-condensing); or the environment is subject to vibration, shocks, or bumps.

## Electrical Installation

Place this machine near an existing power source. Make sure all power cords are protected from traffic, material handling, moisture, chemicals, or other hazards. Make sure to leave enough space around machine to disconnect power supply or apply a lockout/tagout device, if required.

## Lighting

Lighting around the machine must be adequate enough that operations can be performed safely. Shadows, glare, or strobe effects that may distract or impede the operator must be eliminated.

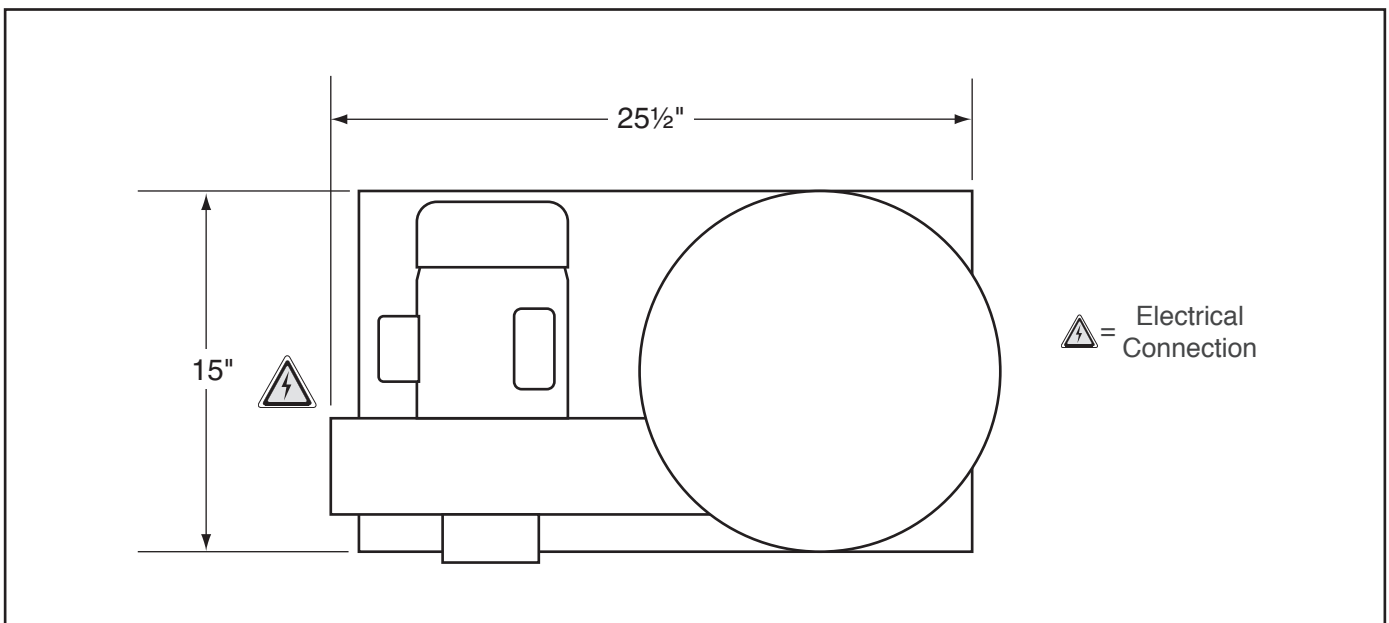

Figure 5. Minimum working clearances.



# Assembly

The machine must be fully assembled before it can be operated. Before beginning the assembly process, refer to **Needed for Setup** and gather all listed items. To ensure the assembly process goes smoothly, first clean any parts that are covered or coated in heavy-duty rust preventative (if applicable).

## To assemble machine:

1. Attach (4) swivel casters to base plate with (16) M5-.8 x 10 Phillips head screws, 5mm flat washers, and M5-.8 hex nuts (see **Figure 6**).

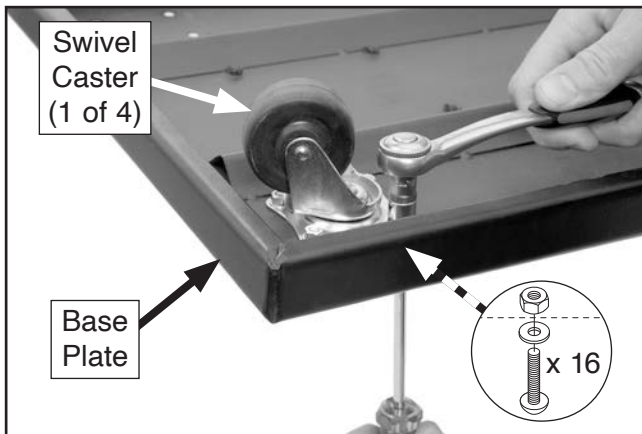

**Figure 6.** Attaching swivel casters to base plate.

2. Attach column and motor plate assembly to other side of base plate with (4) M8-1.25 x 15 hex bolts and 8mm flat washers (see **Figure 7**).

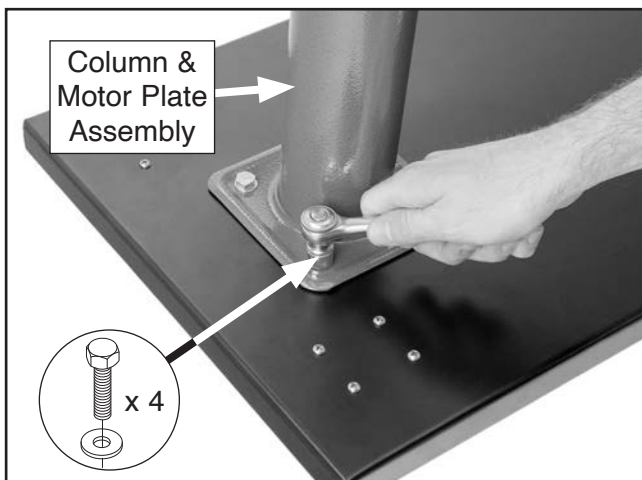

**Figure 7.** Attaching column and motor plate assembly.

3. Attach motor/impeller housing to motor plate with (4) M8-1.25 x 15 hex bolts, (8) 8mm flat washers, and (4) M8-1.25 hex nuts (see **Figure 8**).

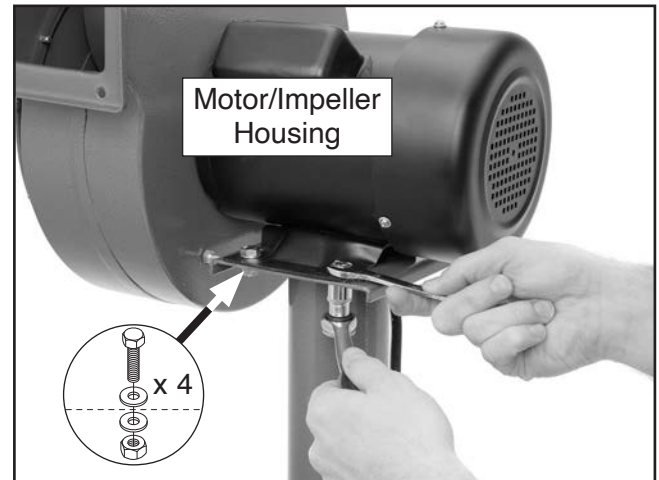

**Figure 8.** Attaching motor/impeller housing to motor plate.

4. Align rubber gasket with collector mounting holes (see **Figure 9**).
5. Attach collector to motor/impeller housing with (6) M6-1 x 15 hex bolts, securing rubber gasket between them (see **Figure 9**).

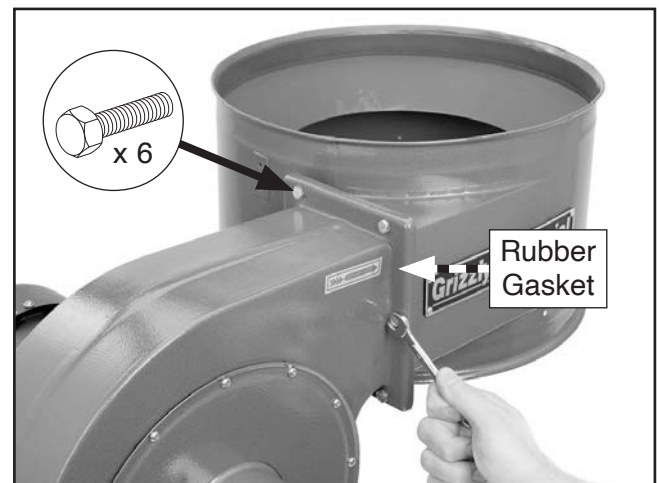

**Figure 9.** Attaching collector to motor/impeller housing (rubber gasket hidden by motor/impeller housing).



- Attach (2) collection bag support rods to collector with (2) M5-.8 x 15 Phillips head screws, 5mm flat washers, and M5-.8 hex nuts (see **Figure 10**).



**Figure 10.** Attaching collection bag support rods to collector.

- Attach (2) collection bag support rods to base plate with (4) M5-.8 x 15 Phillips head screws, and 5mm flat washers (see **Figure 11**).

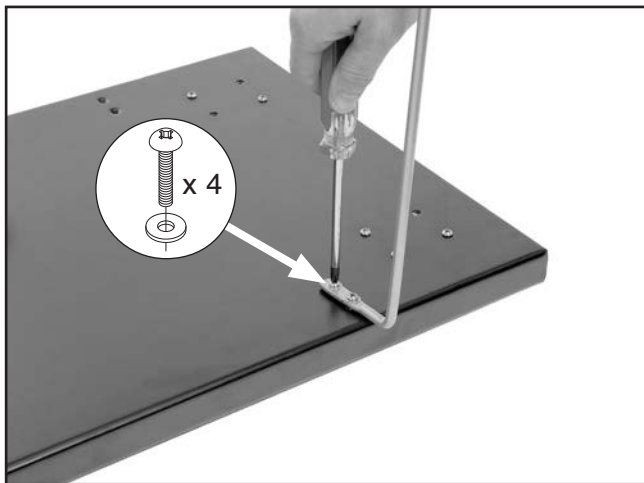

**Figure 11.** Attaching collection bag support rods to base plate.

- Attach upper bag support rod to collector with (2) M4-.7 x 8 Phillips head screws (see **Figure 12**).

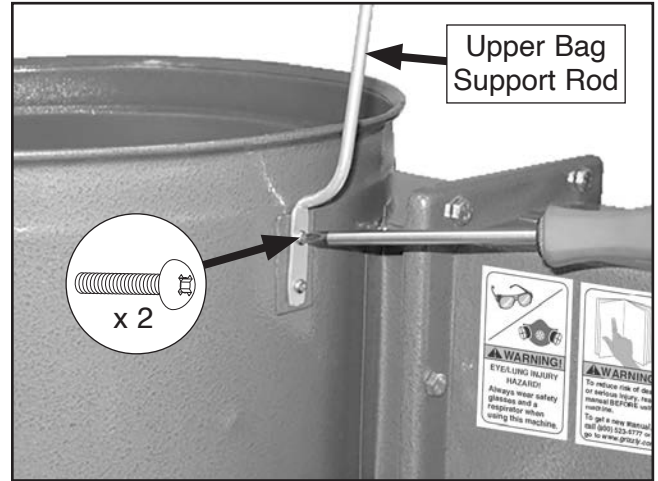

**Figure 12.** Attaching upper bag support rod to collector.

- Adjust (2) hex bolts on motor plate so bolt heads press against impeller housing (see **Figure 13**).
- Without moving bolts, tighten (2) hex nuts shown in **Figure 13** to secure bolts.

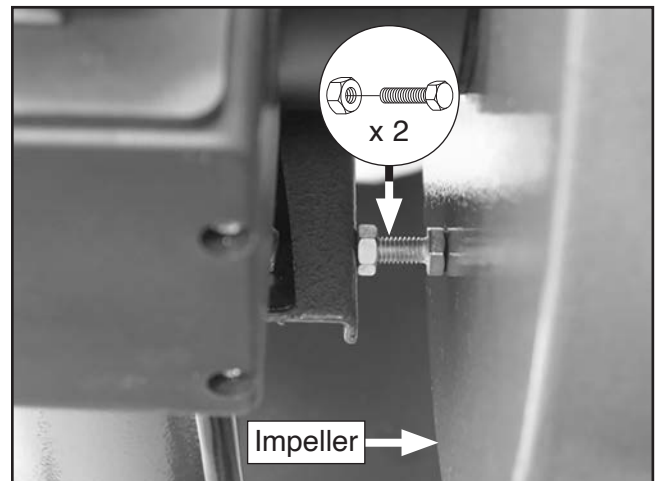

**Figure 13.** Location of motor plate bolts.



11. Place clear collection bag over bottom edge of collector and secure with (1) bag clamp (see **Figure 14**).

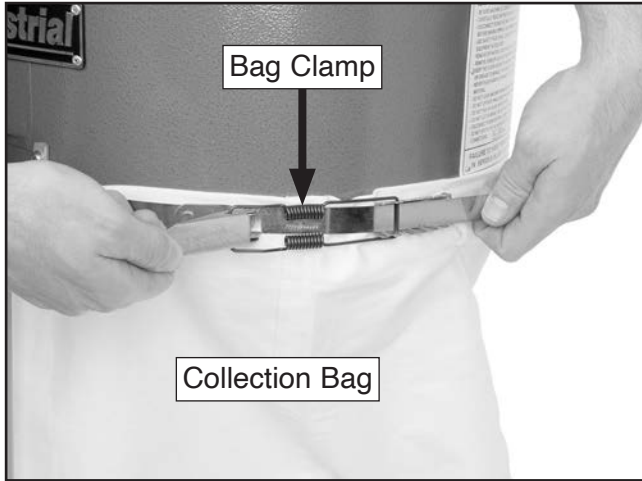

**Figure 14.** Example of securing collection bag with bag clamp.

**Note:** Place spring bar between belt and latch, as shown in **Figure 15**, then hook spring bar to cleats on other end of belt and tighten latch to secure.

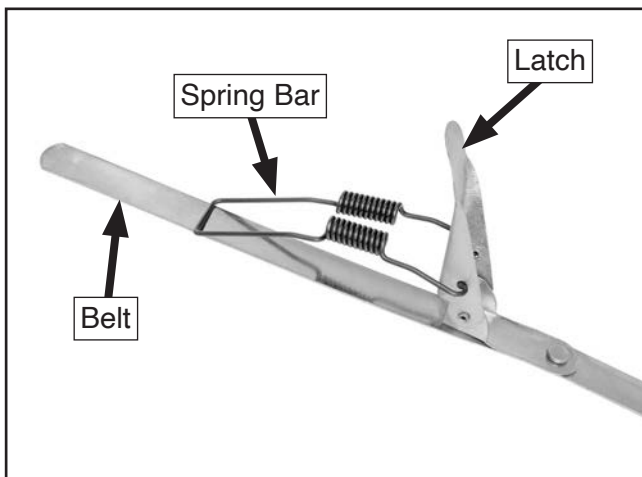

**Figure 15.** Bag clamp components.

12. Thread cleated end of remaining bag clamp all the way through opening in filter bag rim.
13. Hook top of filter bag to upper bag support rod, then use bag clamp to secure filter bag to upper edge of collector (see **Figure 16**).

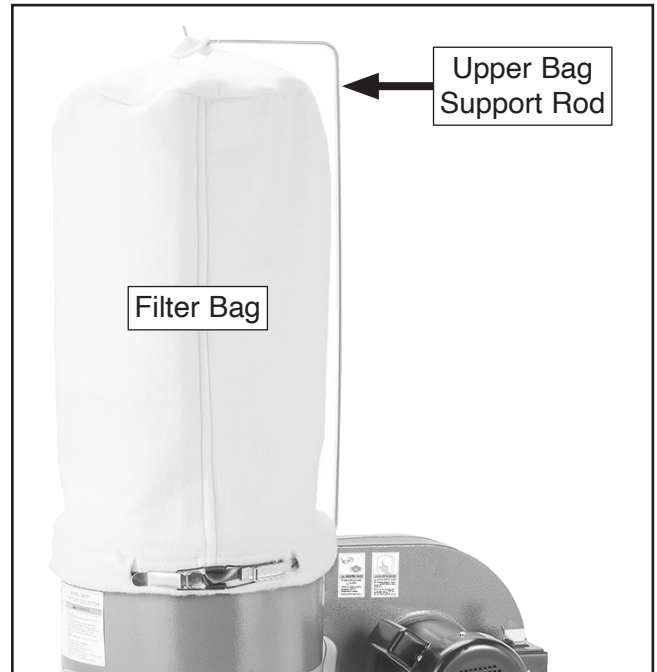

**Figure 16.** Filter bag installed.



# Collection System

## Material Selection

You have many choices regarding dust collection ducting, but flexible hose is the most common for this size of machine. However, be aware that there is a fire or explosion hazard if plastic duct material is used for dust collection without being grounded against static electrical charge build-up.

Flexible rubber hose, polyethylene, plastic flex-hose and other flexible ribbed hose is generally used for short runs. There are many different types of flex hose on the market today. These are manufactured from materials such as polyethylene, PVC, cloth hose dipped in rubber and even metal, including steel and aluminum.

If using flex-hose, you should choose one of the many types that are designed specifically for the movement of solid particles, such as wood dust. However, the cost of specifically designed flexible duct can vary greatly. Grizzly offers polyethylene and steel flex hose.

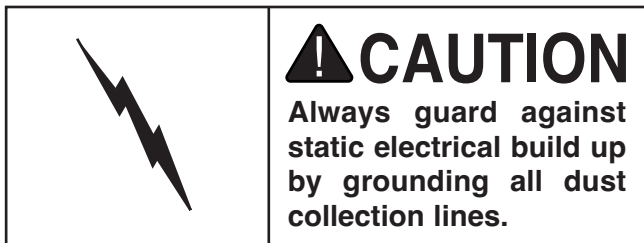

## Duct Grounding

Plastic flex-hose is an insulator, and dust particles moving against the walls of the hose creates a static electrical build up. This charge will build until it discharges to a ground. If a grounding medium is not available to prevent static electrical build up, the electrical charge will arc to the nearest grounded source. This electrical discharge may cause an explosion and subsequent fire inside the system.

To protect against static electrical build up inside a non-conducting duct, a bare copper wire should be placed inside the duct along its length and grounded to the dust collector. You must also confirm that the dust collector is continuously grounded through the electrical circuit to the electric service panel.

Be sure that you extend the bare copper wire down all branches of the system. Do not forget to connect the wires to each other with wire nuts when two branches meet at a “Y” or “T” connection.

Ensure that the entire system is grounded. If using plastic blast gates to direct air flow, the grounding wire must be jumped (see the figure below) around the blast gate without interruption to the

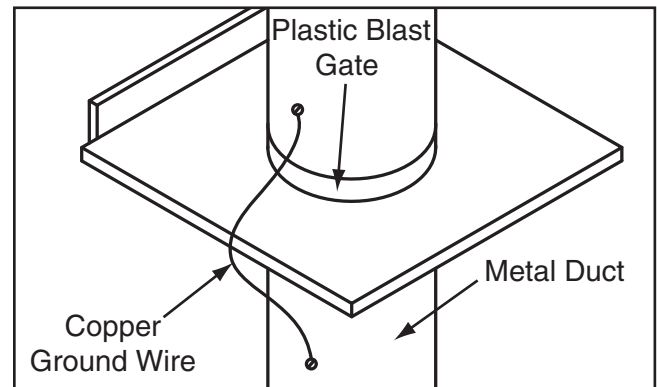

**Figure 17.** Ground jumper wire when using plastic blast gates or elbows and metal duct.

We also recommend wrapping the outside of all plastic ducts with bare copper wire to ground the outside of the system against static electrical buildup. Wire connections at Y’s and T’s should be made with wire nuts.

Attach the bare ground wire to each stationary woodworking machine and attach to the dust collector frame with a ground screw as shown in the figure below. Ensure that each machine is continuously grounded to the grounding terminal in your electric service panel.

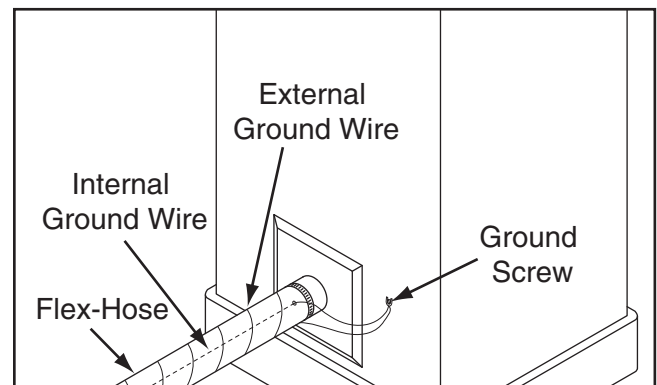

**Figure 18.** Flex-hose grounded to machine.



## Dust Collection

Since each machine produces a different amount of sawdust, the requirements for the minimum amount of CFM to move that sawdust is unique to the machine (for example, a planer produces more sawdust than a table saw). Knowing this required CFM is important to gauging which size of duct to use.

Refer to the figure below for a close estimation of the airflow each machine requires. Keep in mind that machines that generate the most sawdust should be placed closest to the dust collector. If the machine has multiple dust ports, the total CFM required is the sum of all ports.

| Machine Dust Port Size | Approximate Required CFM |
|------------------------|--------------------------|
| 2"                     | 100                      |
| 2.5"                   | 150                      |
| 3"                     | 250                      |
| 4"                     | 400                      |
| 5"                     | 600                      |
| 6"                     | 850                      |
| 7"                     | 1200                     |
| 8"                     | 1600                     |
| 9"                     | 2000                     |
| 10"                    | 2500                     |

**Figure 19.** Approximate required airflow for machines, based on dust port size.

If the machine does not have a built-in dust port, use the following table to determine which size of dust port to install.

| Machine                                   | Average Dust Port Size |
|---|------------------------|
| Table Saw.....                            | 4"                     |
| Miter/Radial-Arm Saw.....                 | 2"                     |
| Jointer (6" and smaller) .....            | 4"                     |
| Jointer (8"-12") .....                    | 5"                     |
| Thickness Planer (13" and smaller).....   | 4"                     |
| Thickness Planer (14"-20") .....          | 6"                     |
| Shaper.....                               | 4"                     |
| Router (mounted to table).....            | 2"                     |
| Bandsaw.....                              | 4"                     |
| Lathe.....                                | 4"                     |
| Disc Sander (12" and smaller).....        | 2"                     |
| Disc Sander (13-18").....                 | 4"                     |
| Belt Sander (6" and smaller) .....        | 2"                     |
| Belt Sander (7"-9") .....                 | 3"                     |
| Edge Sander (6" x 80" and smaller).....   | 4"                     |
| Edge Sander (6" x 80" and larger) .....   | 5"                     |
| Drum Sander (24" and smaller).....        | 2 x 4"                 |
| Drum Sander (24" and larger) .....        | 4 x 4"                 |
| Widebelt Sander (18" and smaller).....    | 5"                     |
| Widebelt Sander (24"-37" single head) ... | 2 x 6"                 |
| Widebelt Sander (24"-51" double head) ..  | 5 x 4"                 |

**Figure 20.** Dust port size and quantity per average machine.

To solve any other dust collection questions, Grizzly offers a guide book entitled *Dust Collection Basics* that will help you design your system.

### W1050—Dust Collection Basics Book

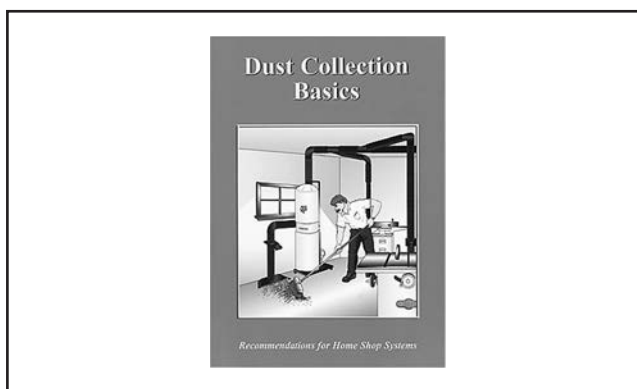

**Figure 21.** W1050 Dust Collection Basics Book.



# Test Run

Once assembly is complete, test run the machine to ensure it is properly connected to power and safety components are functioning correctly.

If you find an unusual problem during the test run, immediately stop the machine, disconnect it from power, and fix the problem **BEFORE** operating the machine again. The **Troubleshooting** table in the **SERVICE** section of this manual can help.

The Test Run consists of verifying the following:  
1) The motor powers up and runs correctly, and  
2) the safety disabling mechanism on the ON/OFF switch works correctly.

## **!WARNING**

**Serious injury or death can result from using this machine BEFORE understanding its controls and related safety information. DO NOT operate, or allow others to operate, machine until the information is understood.**

## **!WARNING**

**DO NOT start machine until all preceding setup instructions have been performed. Operating an improperly set up machine may result in malfunction or unexpected results that can lead to serious injury, death, or machine/property damage.**

### To test run machine:

1. Clear all setup tools away from machine.
2. Connect machine to dust collection system or cover inlet.

**IMPORTANT:** DO NOT operate dust collector without first connecting it to dust collection system or covering inlet. Otherwise, lack of airflow resistance will cause motor to operate at full amperage load, which could trip your circuit breaker or blow fuse.

3. Connect machine to power.

4. Use ON/OFF switch to turn machine **ON** (see **Figure 22**), verify motor operation, and then turn machine **OFF**.

Motor should run smoothly and without unusual problems or noises.

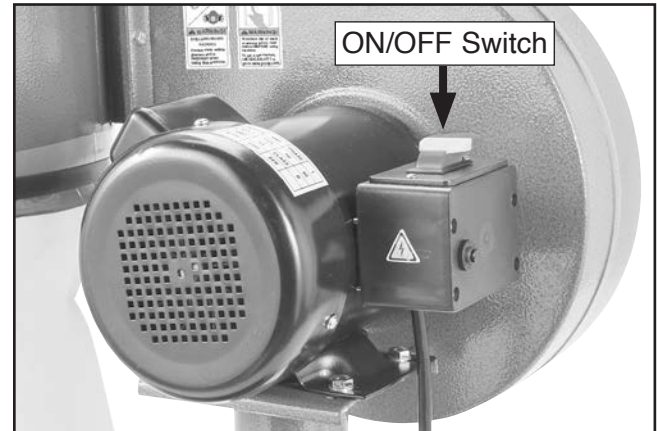

**Figure 22.** Location of ON/OFF switch.

5. Remove switch disabling key from ON/OFF switch, as shown in **Figure 23**.

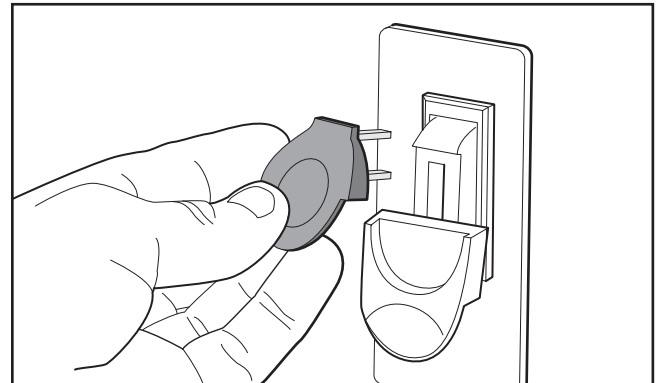

**Figure 23.** Removing switch key from ON/OFF switch.

6. Try to start machine with ON/OFF switch. Machine should not start.

— If machine *does not* start, switch disabling feature is working correctly.

— If machine *does start*, immediately stop machine. Switch disabling feature is not working correctly. This safety feature must work properly before proceeding with regular operations. Call Tech Support for help.



# SECTION 4: OPERATIONS

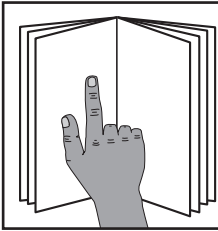

## **!WARNING**

To reduce your risk of serious injury, read this entire manual **BEFORE** using machine.

## **!WARNING**

To reduce risk of eye injury from flying chips or lung damage from breathing dust, always wear safety glasses and a respirator when operating this machine.

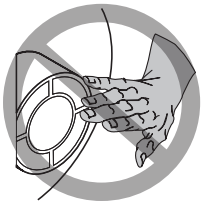
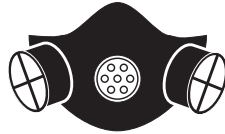

## **!WARNING**

**DO NOT** put hands or small objects near inlet opening during operation. Objects sucked into inlet will meet with impeller blade. Failure to heed this warning could result in personal injury or property damage.

## **!WARNING**

Never place dust collector in room with open flames or pilot lights. There is a risk of explosion if too much fine dust is dispersed into air with open flame present.

## **NOTICE**

If you are not experienced with this type of machine, **WE STRONGLY RECOMMEND** that you seek additional training outside of this manual. Read books/magazines or get formal training before beginning any projects. Regardless of the content in this section, Grizzly Industrial will not be held liable for accidents caused by lack of training.

## General

Keep in mind that the dust collector is intended for single machine use and is not designed to draw dust through long ducting runs and multiple ports simultaneously.

To complete a typical operation, the operator does the following:

1. Positions machine near dust collector and uses appropriate ducting to connect machine to dust collector.
2. Connects ducting ground.
3. Turns woodworking machine, then dust collector **ON**.
4. Performs woodworking operation.
5. Turns woodworking machine, then dust collector **OFF**.

### Tips for Optimum Performance

- Keep duct between dust collector and machine as short as possible. We do not recommend using more than 10' of ducting. The simpler the system, the more efficient and less costly it will be.
- Ridges inside flexible hose greatly increase static pressure loss, which reduces suction performance.
- Keep ducting directional changes to a minimum. The more curved fittings you use, the greater the loss of suction at dust-producing machine.
- Gradual directional changes are more efficient than sudden directional changes (i.e. use 45° elbows in place of 90° elbows whenever possible).



# SECTION 5: ACCESSORIES

## **!WARNING**

Installing unapproved accessories may cause machine to malfunction, resulting in serious personal injury or machine damage. To reduce this risk, only install accessories recommended for this machine by Grizzly.

## **NOTICE**

Refer to our website or latest catalog for additional recommended accessories.

- D4206—Clear Flexible Hose 4" x 10'
- D4256—45° Elbow 4"
- W1034—Heavy-Duty Clear Flex Hose 4" x 10'
- D2107—Hose Hanger 4 ¼"
- W1015—Y-Fitting 4" x 4" x 4"
- W1017—90° Elbow 4"
- W1019—Hose Coupler (Splice) 4"
- W1317—Wire Hose Clamp 4"
- W1007—Plastic Blast Gate 4"
- W1053—Anti-Static Grounding Kit

We have hand picked a selection of commonly used dust collection components for machines with 4" dust ports.



Figure 24. Dust collection accessories.

## Replacement Bags

- G1034—2.5 Micron Fabric Filter Bag
- G5557—2.5 Micron Non-Woven Fabric Filter Bag
- G5051—30 Micron Fabric Collection Bag
- T24268—Plastic Collection Bag

To ensure consistent results, buy Grizzly replacement dust collector bags. Keep several spares on hand.

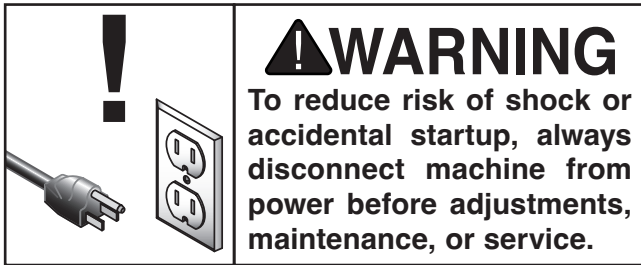

Figure 25. Assorted replacement bags.

**order online at [www.grizzly.com](http://www.grizzly.com) or call 1-800-523-4777**



# SECTION 6: MAINTENANCE



## Schedule

For optimum performance from this machine, this maintenance schedule must be strictly followed.

### Ongoing

To minimize your risk of injury and maintain proper machine operation, shut down the machine immediately if you ever observe any of the items below, and fix the problem before continuing operations:

- Loose mounting bolts.
- Worn switch
- Worn or damaged wires.
- Full collection bag.
- Any other unsafe condition.

## Lubrication

Since all bearings are shielded and permanently lubricated, simply leave them alone until they need to be replaced. DO NOT lubricate them.

## Machine Storage

When the dust collector is not in use, unplug the power cord from the power source. Place the cord away from potential damage sources, such as high traffic areas, sharp objects, heat sources, harsh chemicals, water, damp areas, etc.

## Emptying/Replacing Bags

Empty or replace the collection bag when it is about 1/2 full. Replace the filter bag on a regular basis to allow the machine to operate at a much higher level of efficiency. Always wear the appropriate respirator or dust mask and safety glasses during this process, as small dust particles can escape the bags, causing them to become airborne and easily inhaled. This microscopic airborne dust is unsafe to breathe and can serious health problems.

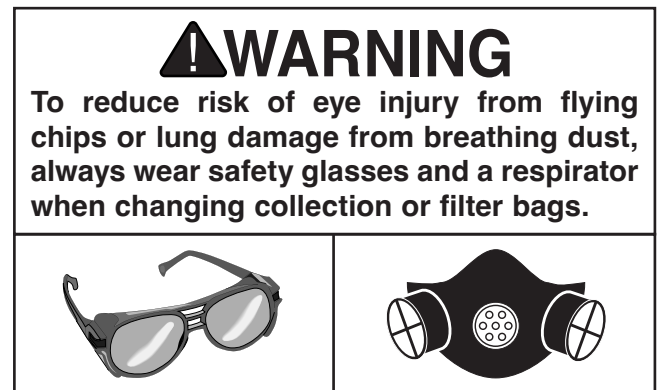

To empty/replace bags:

1. DISCONNECT MACHINE FROM POWER!
2. Put on safety glasses and respirator.
3. Release bag clamp securing bag, unhook bag from support rods, then remove bag from collector.
4. Empty bag or securely close top and safely dispose of it according to local and federal standards.
5. Re-install bag or replace it with a new one.



# SECTION 7: SERVICE

Review the troubleshooting procedures in this section if a problem develops with your machine. If you need replacement parts or additional help with a procedure, call our Technical Support. **Note:** *Please gather the serial number and manufacture date of your machine before calling.*

## Troubleshooting

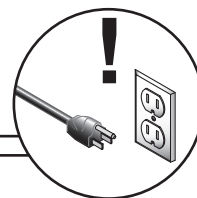

### Motor & Electrical

| Symptom  | Possible Cause  | Possible Solution  |
|--|---|--|
| Machine does not start, or power supply breaker immediately trips after startup. | <ol style="list-style-type: none"> <li>1. Switch disabling key removed.</li> <li>2. Overload switch tripped.</li> <li>3. Incorrect power supply voltage or circuit size.</li> <li>4. Power supply circuit breaker tripped or fuse blown.</li> <li>5. Start capacitor at fault.</li> <li>6. Centrifugal switch adjustment/contact points at fault.</li> <li>7. Wiring broken, disconnected, or corroded.</li> <li>8. ON/OFF switch or overload switch at fault.</li> <li>9. Motor or motor bearings at fault.</li> </ol> | <ol style="list-style-type: none"> <li>1. Install switch disabling key.</li> <li>2. Reset overload switch (<b>Page 4</b>).</li> <li>3. Ensure correct power supply voltage and circuit size (<b>Page 10</b>).</li> <li>4. Ensure circuit is free of shorts. Reset circuit breaker or replace fuse.</li> <li>5. Test/replace if at fault.</li> <li>6. Adjust centrifugal switch/clean contact points. Replace either if at fault.</li> <li>7. Fix broken wires or disconnected/corroded connections (<b>Page 28</b>).</li> <li>8. Replace switch.</li> <li>9. Replace motor.</li> </ol>                                   |
| Machine stalls or is underpowered.   | <ol style="list-style-type: none"> <li>1. Dust collection ducting problem.</li> <li>2. Filter bag clogged/at fault.</li> <li>3. Dust collector undersized.</li> <li>4. Motor overheated, tripping overload switch.</li> <li>5. Extension cord too long.</li> <li>6. Centrifugal switch/contact points at fault.</li> <li>7. Motor or motor bearings at fault.</li> </ol>  | <ol style="list-style-type: none"> <li>1. Clear blockages, seal leaks, use smooth wall duct, eliminate bends (<b>Page 22</b>).</li> <li>2. Replace filter bag (<b>Page 24</b>).</li> <li>3. Move closer to machine/redesign ducting layout (<b>Page 22</b>)/upgrade to larger dust collector.</li> <li>4. Clean motor, let cool, and reduce workload. Reset overload switch (<b>Page 4</b>).</li> <li>5. Move machine closer to power supply; use shorter extension cord (<b>Page 11</b>).</li> <li>6. Adjust centrifugal switch/clean contact points. Replace either if at fault.</li> <li>7. Replace motor.</li> </ol> |
| Machine has vibration or noisy operation.  | <ol style="list-style-type: none"> <li>1. Motor or component loose.</li> <li>2. Motor fan rubbing on fan cover.</li> <li>3. Centrifugal switch needs adjustment/at fault.</li> <li>4. Motor bearings at fault.</li> </ol>   | <ol style="list-style-type: none"> <li>1. Replace damaged or missing bolts/nuts or tighten if loose.</li> <li>2. Fix/replace fan cover; replace loose/damaged fan.</li> <li>3. Adjust/replace if at fault.</li> <li>4. Test by rotating shaft; rotational grinding/loose shaft requires bearing replacement.</li> </ol>  |



## Operation

| Symptom   | Possible Cause  | Possible Solution   |
|---|---|---|
| Loud, repetitious noise, or excessive vibration coming from dust collector. | <ol style="list-style-type: none"> <li>1. Dust collector not on flat surface and wobbles.</li> <li>2. Swivel caster fasteners loose or not installed properly.</li> <li>3. Impeller damaged and unbalanced.</li> <li>4. Impeller loose on motor shaft.</li> </ol>   | <ol style="list-style-type: none"> <li>1. Stabilize dust collector.</li> <li>2. Tighten fasteners or re-install casters.</li> <li>3. Disconnect dust collector from power; inspect impeller for cracks or damage; replace impeller if damaged.</li> <li>4. Secure impeller (<b>Page 27</b>); replace motor and impeller as a set if motor shaft and impeller hub are damaged.</li> </ol>  |
| Dust collector does not adequately collect dust or chips; poor performance. | <ol style="list-style-type: none"> <li>1. Collection bag full.</li> <li>2. Filter bag clogged/at fault.</li> <li>3. Ducting blocked/restricted.</li> <li>4. Dust collector too far away from point of suction; duct clamps not properly secured; too many sharp bends in ducting.</li> <li>5. Wood wet/green and dust not flowing smoothly through ducting.</li> <li>6. Ducting has one or more leaks.</li> <li>7. Ducting and ports are incorrectly sized.</li> <li>8. Dust collector undersized.</li> </ol> | <ol style="list-style-type: none"> <li>1. Empty/replace collection bag (<b>Page 24</b>).</li> <li>2. Replace filter bag (<b>Page 24</b>).</li> <li>3. Remove ducting from dust collector inlet and unblock restriction. A plumbing snake may be necessary.</li> <li>4. Relocate dust collector closer to point of suction; re-secure ducts; remove sharp bends (<b>Page 22</b>).</li> <li>5. Only collect dust from wood with less than 20% moisture content.</li> <li>6. Seal/eliminate ducting leaks.</li> <li>7. Install correctly sized ducts and fittings (<b>Page 20</b>).</li> <li>8. Upgrade to larger dust collector.</li> </ol> |
| Dust collector blows sawdust into the air.                                  | <ol style="list-style-type: none"> <li>1. Duct clamp(s) or bag(s) not properly clamped and secured; ducting loose/damaged.</li> </ol>   | <ol style="list-style-type: none"> <li>1. Secure ducts and bags, making sure duct/bag clamp(s) are tight; tighten/replace ducting.</li> </ol>   |



# Tightening Impeller

Periodically check the impeller to make sure it is tight on the motor shaft. Any unusual vibration or noise may be an indication that the impeller has loosened. A left-hand cap screw secures the impeller to the shaft. It can be accessed through the inlet cover with a long hex wrench (at least 4"), or by removing the inlet cover, as shown in the following steps.

| Tools Needed                       | Qty |
|------------------------------------|-----|
| Phillips Head Screwdriver #2 ..... | 1   |
| Hex Wrench 5mm.....                | 1   |

## To tighten impeller:

1. DISCONNECT MACHINE FROM POWER!
2. Remove (12) Phillips head screws shown in **Figure 26** to remove inlet cover.

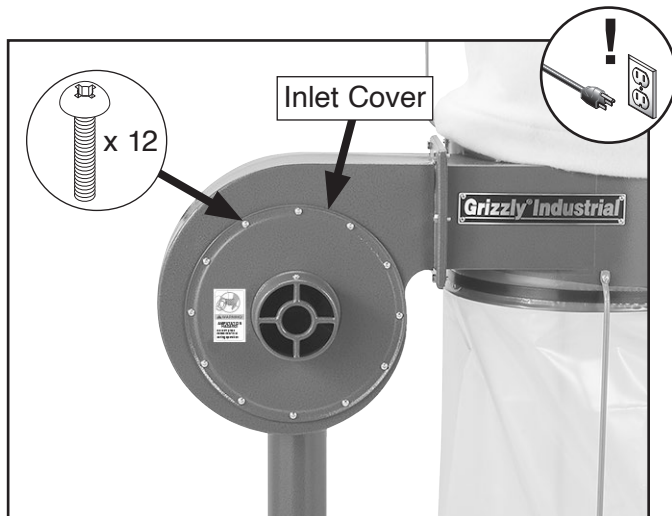

**Figure 26.** Location of inlet cover and securing screws.

3. Tighten left-hand cap screw (see **Figure 27**).



**Figure 27.** Location of impeller cap screw.

4. Install inlet cover with screws removed in **Step 2**.



# SECTION 8: WIRING

These pages are current at the time of printing. However, in the spirit of improvement, we may make changes to the electrical systems of future machines. Compare the manufacture date of your machine to the one stated in this manual, and study this section carefully.

If there are differences between your machine and what is shown in this section, call Technical Support at (570) 546-9663 for assistance BEFORE making any changes to the wiring on your machine. An updated wiring diagram may be available. **Note:** *Please gather the serial number and manufacture date of your machine before calling. This information can be found on the main machine label.*

## WARNING

### Wiring Safety Instructions

**SHOCK HAZARD.** Working on wiring that is connected to a power source is extremely dangerous. Touching electrified parts will result in personal injury including but not limited to severe burns, electrocution, or death. Disconnect the power from the machine before servicing electrical components!

**MODIFICATIONS.** Modifying the wiring beyond what is shown in the diagram may lead to unpredictable results, including serious injury or fire. This includes the installation of unapproved after-market parts.

**WIRE CONNECTIONS.** All connections must be tight to prevent wires from loosening during machine operation. Double-check all wires disconnected or connected during any wiring task to ensure tight connections.

**CIRCUIT REQUIREMENTS.** You MUST follow the requirements at the beginning of this manual when connecting your machine to a power source.

**WIRE/COMPONENT DAMAGE.** Damaged wires or components increase the risk of serious personal injury, fire, or machine damage. If you notice that any wires or components are damaged while performing a wiring task, replace those wires or components.

**MOTOR WIRING.** The motor wiring shown in these diagrams is current at the time of printing but may not match your machine. If you find this to be the case, use the wiring diagram inside the motor junction box.















**CAPACITORS/INVERTERS.** Some capacitors and power inverters store an electrical charge for up to 10 minutes after being disconnected from the power source. To reduce the risk of being shocked, wait at least this long before working on capacitors.

**EXPERIENCING DIFFICULTIES.** If you are experiencing difficulties understanding the information included in this section, contact our Technical Support at (570) 546-9663.

#### NOTICE

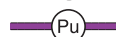
The photos and diagrams included in this section are best viewed in color. You can view these pages in color at [www.grizzly.com](http://www.grizzly.com).

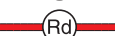
#### COLOR KEY

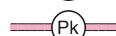
|   |  |  |  |
|---|--|--|--|
| BLACK  | BLUE    | YELLOW        | LIGHT BLUE  |
| WHITE  | BROWN   | YELLOW GREEN  | BLUE WHITE  |
| GREEN  | GRAY    | PURPLE        | TURQUOISE   |
| RED    | ORANGE  | PINK          |  |



# Wiring Diagram

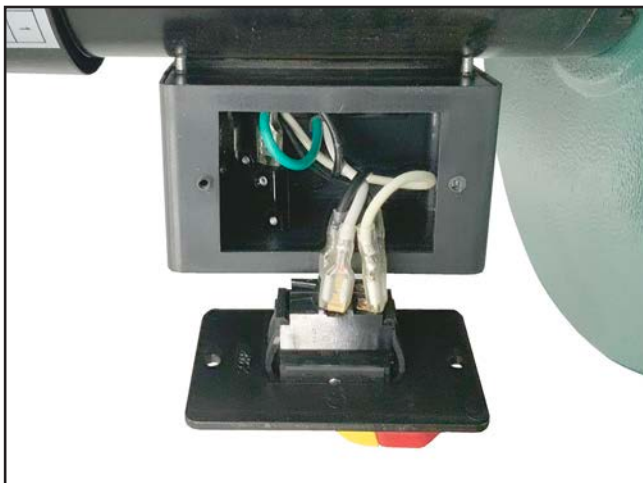
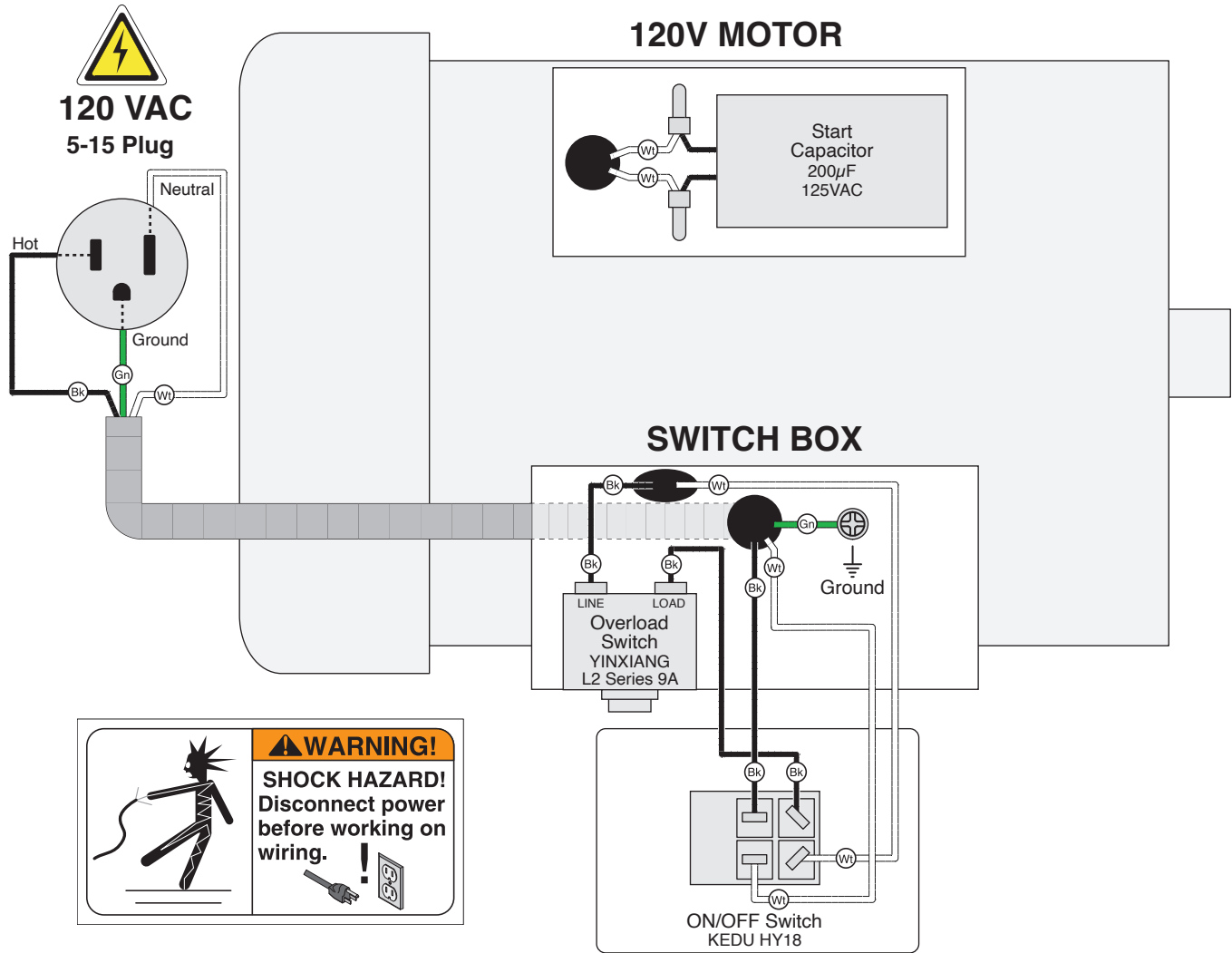

Figure 28. Control box wiring.

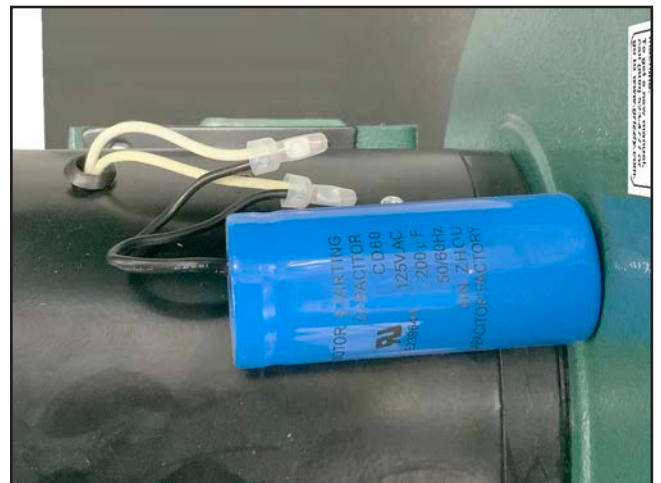

Figure 29. Start capacitor wiring.



# SECTION 9: PARTS

We do our best to stock replacement parts when possible, but we cannot guarantee that all parts shown are available for purchase. Call (800) 523-4777 or visit [www.grizzly.com/parts](http://www.grizzly.com/parts) to check for availability.

## Main

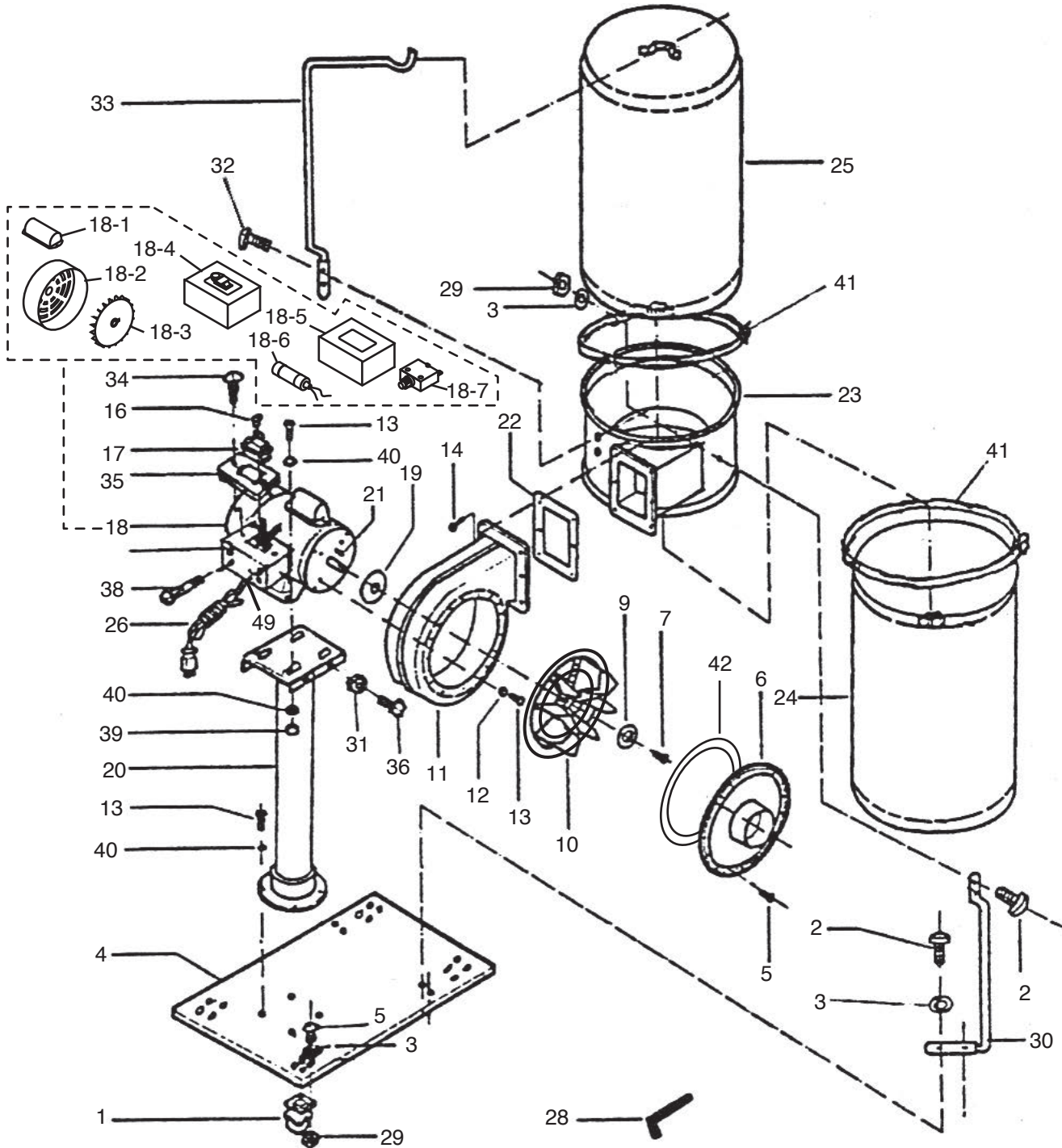

# Main Parts List

| REF  | PART #     | DESCRIPTION                          |
|------|------------|--------------------------------------|
| 1    | P8027001   | SWIVEL CASTER                        |
| 2    | P8027002   | PHLP HD SCR M5-.8 X 15               |
| 3    | P8027003   | FLAT WASHER 5MM                      |
| 4    | P8027004   | BASE PLATE                           |
| 5    | P8027005   | PHLP HD SCR M5-.8 X 10               |
| 6    | P8027006   | INLET COVER                          |
| 7    | P8027007   | CAP SCREW M6-1 X 20 LH               |
| 9    | P8027009   | FENDER WASHER 6MM                    |
| 10   | P8027010   | IMPELLER                             |
| 11   | P8027011   | IMPELLER HOUSING                     |
| 12   | P8027012   | LOCK WASHER 8MM                      |
| 13   | P8027013   | HEX BOLT M8-1.25 X 15                |
| 14   | P8027014   | HEX BOLT M6-1 X 15                   |
| 16   | P8027016   | SWITCH SAFETY KEY                    |
| 17   | P8027017   | PADDLE SWITCH KEDU HY18              |
| 18   | P8027018   | MOTOR 1HP 110V 1-PH                  |
| 18-1 | P8027018-1 | CAPACITOR COVER                      |
| 18-2 | P8027018-2 | MOTOR FAN COVER                      |
| 18-3 | P8027018-3 | MOTOR FAN                            |
| 18-4 | P8027018-4 | COMPLETE SWITCH BOX                  |
| 18-5 | P8027018-5 | SWITCH BOX COVER                     |
| 18-6 | P8027018-6 | S CAPACITOR 200M 125V 1-1/2 X 2-3/4  |
| 18-7 | P8027018-7 | OL SWITCH YINXIANG 9A 125/250V 50VDC |

| REF | PART #   | DESCRIPTION                       |
|-----|----------|-----------------------------------|
| 19  | P8027019 | RUBBER GASKET                     |
| 20  | P8027020 | COLUMN & MOTOR PLATE              |
| 21  | P8027021 | FLAT PIN 5 X 30                   |
| 22  | P8027022 | RUBBER GASKET                     |
| 23  | P8027023 | COLLECTOR                         |
| 24  | P8027024 | COLLECTION BAG                    |
| 25  | P8027025 | FILTER BAG 2.5 MICRON 14.5" X 23" |
| 26  | P8027026 | POWER CORD 16G 3W 73"             |
| 28  | P8027028 | HEX WRENCH 5MM                    |
| 29  | P8027029 | HEX NUT M5-.8                     |
| 30  | P8027030 | COLLECTOR BAG SUPPORT ROD         |
| 31  | P8027031 | HEX NUT M6-1                      |
| 32  | P8027032 | PHLP HD SCR M4-.7 X 8             |
| 33  | P8027033 | UPPER BAG SUPPORT ROD             |
| 34  | P8027034 | TAP SCREW M4 X 12                 |
| 35  | P8027035 | SWITCH PLATE                      |
| 36  | P8027036 | HEX BOLT M6-1 X 25                |
| 38  | P8027038 | CAP SCREW M6-1 X 6                |
| 39  | P8027039 | HEX NUT M8-1.25                   |
| 40  | P8027040 | FLAT WASHER 8MM                   |
| 41  | P8027041 | BAG CLAMP 48"                     |
| 42  | P8027042 | RUBBER GASKET                     |
| 49  | P8027049 | STRAIN RELIEF TYPE-1 5/8          |



# Labels & Cosmetics

43V3

**Grizzly Industrial** MODEL G8027  
1 HP DUST COLLECTOR

**Specifications**

Motor: 1 HP, 120V, Single-Phase, 60 Hz  
Full-Load Amp Draw: 2.6A  
Filter Bag Size: 14-1/2" x 24"  
Collection Bag Size: 14-1/2" x 23"  
Suction Capacity: 500 CFM  
Max Static Pressure: 2.70"  
Filter Rating: 2.5 Micron  
Inlet Size: 4"  
Impeller Size: 9"  
Weight: 51 lbs.

**WARNING!**

To reduce the risk of serious injury while using this machine:

1. Read & understand owner's manual before operating.
2. Always wear approved eye protection and respirator.
3. Only plug power cord into a grounded outlet.
4. Only use this machine to collect wood dustchips—never use to collect glass, metal, liquids, asbestos, silica, animal parts, biohazards, burning materials, etc.
5. Always disconnect power before servicing or cleaning.
6. DO NOT expose to rain or use in wet locations.
7. Keep hands, long hair, and loose clothing away from inlet.
8. Never leave machine unattended during operation.
9. DO NOT use if cord, plug, or any other electrical equipment becomes damaged—promptly repair.
10. DO NOT use without dust bag or filters in place.
11. Prevent unauthorized use by children or untrained users; restrict access or disable machine when unattended.

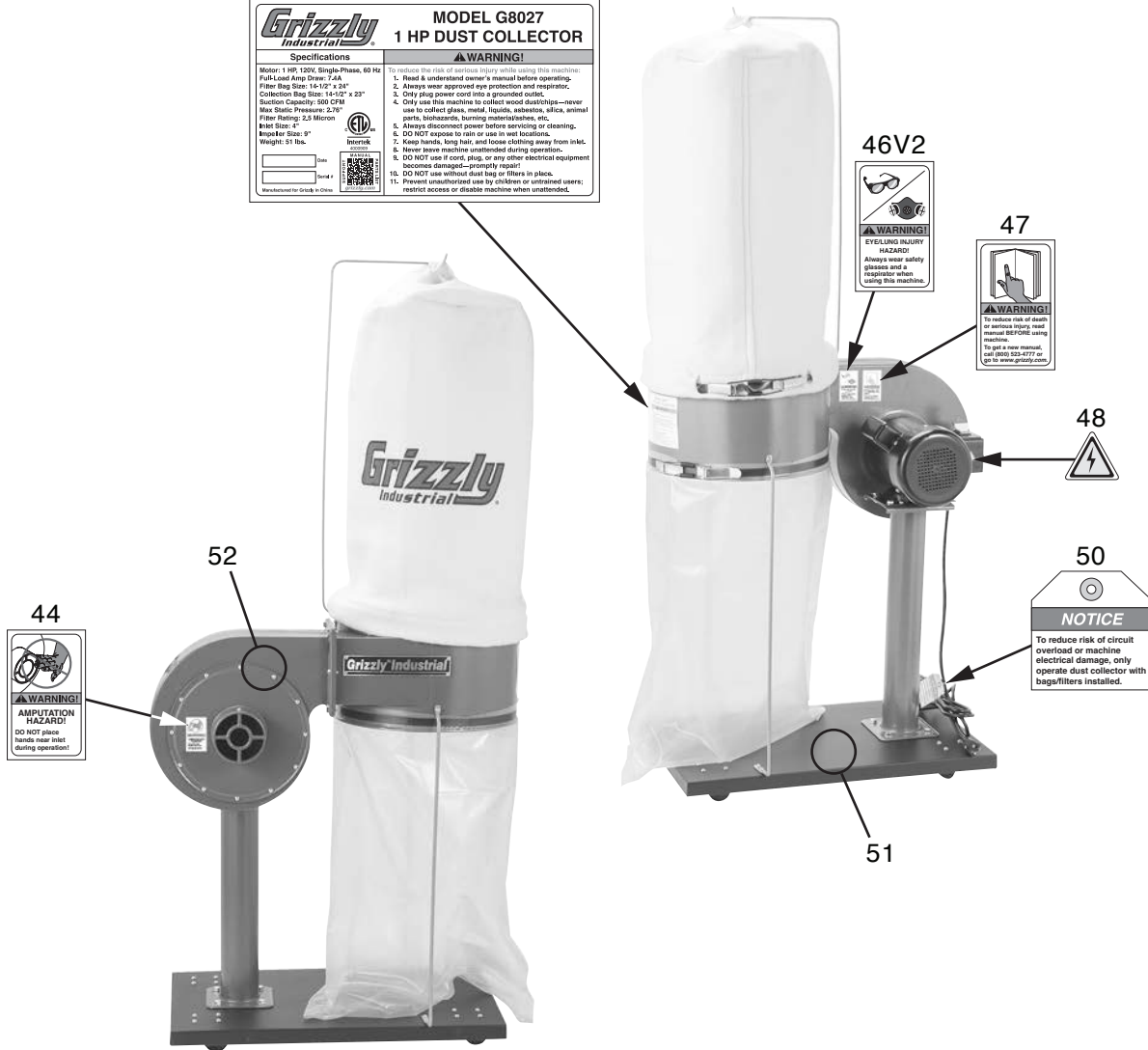

| REF  | PART #     | DESCRIPTION                    |
|------|------------|--------------------------------|
| 43V3 | P8027043V3 | MACHINE ID LABEL V3.04.24      |
| 44   | P8027044   | NO HAND IN INLET LABEL         |
| 46V2 | P8027046V2 | EYE/LUNG INJURY LABEL V2.09.23 |
| 47   | P8027047   | READ MANUAL LABEL              |

| REF | PART #   | DESCRIPTION                   |
|-----|----------|-------------------------------|
| 48  | P8027048 | ELECTRICITY LABEL             |
| 50  | P8027050 | CIRCUIT OVERLOAD HANG TAG     |
| 51  | P8027051 | TOUCH-UP PAINT, GRIZZLY BLACK |
| 52  | P8027052 | TOUCH-UP PAINT, GRIZZLY GREEN |

## ⚠️ WARNING

Safety labels help reduce the risk of serious injury caused by machine hazards. If any label comes off or becomes unreadable, the owner of this machine **MUST** replace it in the original location before resuming operations. For replacements, contact (800) 523-4777 or [www.grizzly.com](http://www.grizzly.com).



# WARRANTY & RETURNS

---

Grizzly Industrial, Inc. warrants every product it sells for a period of **1 year** to the original purchaser from the date of purchase. This warranty does not apply to defects due directly or indirectly to misuse, abuse, negligence, accidents, repairs or alterations or lack of maintenance. This is Grizzly's sole written warranty and any and all warranties that may be implied by law, including any merchantability or fitness, for any particular purpose, are hereby limited to the duration of this written warranty. We do not warrant or represent that the merchandise complies with the provisions of any law or acts unless the manufacturer so warrants. In no event shall Grizzly's liability under this warranty exceed the purchase price paid for the product and any legal actions brought against Grizzly shall be tried in the State of Washington, County of Whatcom.

We shall in no event be liable for death, injuries to persons or property or for incidental, contingent, special, or consequential damages arising from the use of our products.

The manufacturers reserve the right to change specifications at any time because they constantly strive to achieve better quality equipment. We make every effort to ensure that our products meet high quality and durability standards and we hope you never need to use this warranty.

In the event you need to use this warranty, contact us by mail or phone and give us all the details. We will then issue you a "Return Number," which must be clearly posted on the outside as well as the inside of the carton. We will not accept any item back without this number. Proof of purchase must accompany the merchandise.

Please feel free to write or call us if you have any questions about the machine or the manual.

Thank you again for your business and continued support. We hope to serve you again soon.

For further information about the warranty, visit <https://www.grizzly.com/forms/warranty> or scan the QR code below to be automatically directed to our warranty page.



# *grizzly.com*<sup>®</sup>

**TOOL WEBSITE**

Buy Direct and Save with Grizzly<sup>®</sup> – Trusted, Proven and a Great Value!  
~Since 1983~

*Visit Our Website Today For  
Current Specials!*

**ORDER  
24 HOURS A DAY!  
1-800-523-4777**

