



14" PROFESSIONAL CABINET SAW

MODEL G7209 AND G7210

INSTRUCTION MANUAL



COPYRIGHT © 1999 BY GRIZZLY INDUSTRIAL, INC.
**WARNING: NO PORTION OF THIS MANUAL MAY BE REPRODUCED IN ANY SHAPE
OR FORM WITHOUT THE WRITTEN APPROVAL OF GRIZZLY INDUSTRIAL, INC.**
OCTOBER, 2001 PRINTED IN TAIWAN

WARNING

Some dust created by power sanding, sawing, grinding, drilling, and other construction activities contains chemicals known to the State of California to cause cancer, birth defects or other reproductive harm. Some examples of these chemicals are:

- Lead from lead-based paints.
- Crystalline silica from bricks, cement, and other masonry products.
- Arsenic and chromium from chemically treated lumber.

Your risk from these exposures varies, depending on how often you do this type of work. To reduce your exposure to these chemicals: work in a well ventilated area, and work with approved safety equipment, such as those dust masks that are specially designed to filter out microscopic particles.

TABLE OF CONTENTS

| | PAGE |
|---|-------|
| 1. SAFETY | |
| SAFETY RULES FOR POWER TOOLS | 2-3 |
| ADDITIONAL SAFETY INSTRUCTIONS FOR TABLE SAWS | 4 |
| SAFETY ACCESSORIES | 5-6 |
| COMMON DEFINITIONS, TERMS AND PHRASES | 7 |
| 2. CIRCUIT REQUIREMENTS | |
| 220V SINGLE-PHASE | 8 |
| 220V THREE-PHASE | 8 |
| GROUNDING AND EXTENSION CORDS | 9 |
| 3. INFORMATION | |
| COMMENTARY | 10 |
| UNPACKING | 11 |
| PIECE INVENTORY | 11 |
| CLEAN UP | 12 |
| SITE CONSIDERATIONS | 12 |
| 4. ASSEMBLY | |
| BEGINNING ASSEMBLY | 13 |
| EXTENSION WINGS | 13-14 |
| FENCE RAILS | 14-15 |
| GUARD SUPPORT SHAFT | 15 |
| SAW BLADE | 15 |
| MOTOR BRACKET | 15-16 |
| BLADE GUARD | 16-17 |
| TABLE INSERT | 18 |
| 5. ADJUSTMENTS | |
| BLADE HEIGHT | 19 |
| BLADE TILT | 19 |
| MITER SLOT | 20-21 |
| MITER GAUGE | 22 |
| RIP FENCE | 22-23 |
| BLADE ALIGNMENT | 23-24 |
| 6. OPERATIONS | |
| PRE-RUN CHECK | 25 |
| TEST RUN | 25-26 |
| BLADE SELECTION | 26-27 |
| CROSSCUTTING | 27-28 |
| RIPPING | 28 |
| DADO OPERATIONS | 29-30 |
| RABBET OPERATIONS | 30-31 |
| 7. MAINTENANCE | |
| GENERAL | 32 |
| TABLE | 32 |
| V-BELTS | 32-33 |
| LUBRICATION | 33 |
| 8. CLOSURE | 34 |
| MACHINE DATA | 35-36 |
| WIRING DIAGRAM | 37-38 |
| PARTS BREAKDOWNS AND PARTS LISTS | 42-44 |
| PUSH STICK PATTERN | 45 |
| WARRANTY AND RETURNS | 46 |

SECTION 1: SAFETY

WARNING

For Your Own Safety Read Instruction Manual Before Operating This Equipment

The purpose of safety symbols is to attract your attention to possible hazardous conditions. This manual uses a series of symbols and signal words which are intended to convey the level of importance of the safety messages. The progression of symbols is described below. Remember that safety messages by themselves do not eliminate danger and are not a substitute for proper accident prevention measures.



Indicates an imminently hazardous situation which, if not avoided, **WILL** result in death or serious injury.



Indicates a potentially hazardous situation which, if not avoided, **COULD** result in death or serious injury.



Indicates a potentially hazardous situation which, if not avoided, **MAY** result in minor or moderate injury. It may also be used to alert against unsafe practices.

NOTICE

This symbol is used to alert the user to useful information about proper operation of the equipment.

WARNING

Safety Instructions For Power Tools

- KEEP GUARDS IN PLACE** and in working order.
- REMOVE ADJUSTING KEYS AND WRENCHES.** Form habit of checking to see that keys and adjusting wrenches are removed from tool before turning on.
- KEEP WORK AREA CLEAN.** Cluttered areas and benches invite accidents.
- DO NOT USE IN DANGEROUS ENVIRONMENT.** Do not use power tools in damp or wet locations, or where any flammable or noxious fumes may exist. Keep work area well lighted.
- KEEP CHILDREN AND VISITORS AWAY.** All children and visitors should be kept a safe distance from work area.
- MAKE WORKSHOP CHILD PROOF** with padlocks, master switches, or by removing starter keys.
- DO NOT FORCE TOOL.** It will do the job better and safer at the rate for which it was designed.
- USE RIGHT TOOL.** Do not force tool or attachment to do a job for which it was not designed.

WARNING

Safety Instructions For Power Tools

- 9. USE PROPER EXTENSION CORD.** Make sure your extension cord is in good condition. Conductor size should be in accordance with the chart below. The amperage rating should be listed on the motor or tool nameplate. An undersized cord will cause a drop in line voltage resulting in loss of power and overheating. Your extension cord must also contain a ground wire and plug pin. Always repair or replace extension cords if they become damaged.

Minimum Gauge for Extension Cords

| AMP RATING | LENGTH | | |
|------------|--------|------|-------|
| | 25ft | 50ft | 100ft |
| 0-6 | 18 | 16 | 16 |
| 7-10 | 18 | 16 | 14 |
| 11-12 | 16 | 16 | 14 |
| 13-16 | 14 | 12 | 12 |
| 17-20 | 12 | 12 | 10 |
| 21-30 | 10 | 10 | No |

- 10. WEAR PROPER APPAREL.** Do not wear loose clothing, gloves, neckties, rings, bracelets, or other jewelry which may get caught in moving parts. Non-slip footwear is recommended. Wear protective hair covering to contain long hair.
- 11. ALWAYS USE SAFETY GLASSES.** Also use face or dust mask if cutting operation is dusty. Everyday eyeglasses only have impact resistant lenses, they are NOT safety glasses.
- 12. SECURE WORK.** Use clamps or a vise to hold work when practical. It's safer than using your hand and frees both hands to operate tool.
- 13. DO NOT OVER-REACH.** Keep proper footing and balance at all times.
- 14. MAINTAIN TOOLS WITH CARE.** Keep tools sharp and clean for best and safest performance. Follow instructions for lubricating and changing accessories.
- 15. USE RECOMMENDED ACCESSORIES.** Consult the owner's manual for recommended accessories. The use of improper accessories may cause risk of injury.

- 16. REDUCE THE RISK OF UNINTENTIONAL STARTING.** On machines with magnetic contact starting switches there is a risk of starting if the machine is bumped or jarred. Always disconnect from power source before adjusting or servicing. Make sure switch is in OFF position before reconnecting.

- 17. MANY WOODWORKING TOOLS CAN "KICKBACK" THE WORKPIECE** toward the operator if not handled properly. Know what conditions can create "kickback" and know how to avoid them.

- 18. CHECK DAMAGED PARTS.** Before further use of the tool, a guard or other part that is damaged should be carefully checked to determine that it will operate properly and perform its intended function. Check for alignment of moving parts, binding of moving parts, breakage of parts, mounting, and any other conditions that may affect its operation. A guard or other part that is damaged should be properly repaired or replaced.

- 19. NEVER LEAVE TOOL RUNNING UNATTENDED. TURN POWER OFF.** Do not leave tool until it comes to a complete stop.

- 20. NEVER OPERATE A MACHINE WHEN TIRED, OR UNDER THE INFLUENCE OF DRUGS OR ALCOHOL.** Full mental alertness is required at all times when running a machine.

- 21. NEVER ALLOW UNSUPERVISED OR INEXPERIENCED PERSONNEL TO OPERATE THE MACHINE.** Make sure any instructions you give in regards to machine operation are approved, correct, safe, and clearly understood.

- 22. IF AT ANY TIME YOU ARE EXPERIENCING DIFFICULTIES** performing the intended operation, stop using the machine! Then contact our service department or ask a qualified expert how the operation should be performed.

WARNING

Additional Safety Instructions For Table Saws

1. **ALWAYS** use blade guard, splitter and anti-kickback fingers on all "through-sawing" operations. Through-sawing operations are those when the blade cuts completely through the workpiece as in ripping or crosscutting.
2. **AVOID KICKBACKS.** A condition in which a piece of wood is thrown back towards an operator at a high rate of speed. If you do not have a complete understanding of how kickback occurs, or how to prevent it, **DO NOT** operate this table saw.
3. **NEVER** reach behind or over the blade with either hand for any reason.
4. **ALWAYS** use a push-stick for ripping narrow stock.
5. **NEVER** perform any operation "free-hand," which means using only your hands to support or guide the workpiece. Always use either the fence or the miter gauge to position and guide the work.
6. **NEVER** stand or have any part of your body in line with the path of the saw blade.
7. **ALWAYS** hold the work firmly against the miter gauge or fence while holding down against the table.
8. **MOVE** the rip fence out of the way when crosscutting.
9. **NEVER** use the miter gauge and rip fence at the same time.
10. **NEVER** attempt to free a stalled saw blade without first turning the saw OFF.
11. **PROVIDE** adequate support to the rear and sides of the saw table for wide or long workpieces.
12. **AVOID** awkward operations and hand positions where a sudden slip could cause your hand to move into the blade.
13. **IF AT ANY TIME YOU ARE EXPERIENCING DIFFICULTIES** performing the intended operation, stop using the machine! Then contact our service department or ask a qualified expert how the operation should be performed.
14. **ALWAYS LOWER OR REMOVE SAW BLADE WHEN NOT IN USE.**
15. **NEVER USE A DAMAGED SAW BLADE OR ONE THAT HAS BEEN DROPPED.**
16. **USE GREAT CARE WHEN CUTTING WITH A DADO BLADE.** There is a high degree of risk involved with any dado operation. Slight movement of the stock away from the fence will cause kickback.

CAUTION

No list of safety guidelines can be complete. Every shop environment is different. Always consider safety first, as it applies to your individual working conditions. Use this and other machinery with caution and respect. Failure to follow guidelines could result in serious personal injury, damage to equipment or poor work results.

⚠️ WARNING

Statistics prove that most common accidents among table saw users can be linked to kickback. Kickback is typically defined as the high-speed expulsion of stock from the table saw toward its operator. In addition to the danger of the operator or others in the area being struck by the flying stock, it is often the case that the operator's hands are pulled into the blade during the kickback. The following can help minimize kickbacks.

1. Use your blade guard and splitter.
2. Never for any reason place your hand behind the blade. Should kickback occur, your hand will be pulled into the blade.
3. Inspect splitter for alignment between it and your blade.
4. Never use the fence as a guide for crosscutting.
5. Never attempt freehand cuts.
6. Use a pushstick or featherboard to maintain control of your workpiece.
7. Feed cuts through to completion.
8. Stand to the side when ripping.
9. Ensure your fence and miter slot are parallel to the blade.

If you do not have a clear understanding of kickback and how it occurs, do not operate this table saw.

Safety Accessories

Push Sticks

The use of push sticks, particularly when cutting small or narrow workpieces, provides a double benefit for saw operators. The push stick provides added leverage, enabling the operator to keep the workpiece firmly supported against the fence and table. At the same time, the push stick keeps the operator's hand safely away from the rotation of the saw blade. See the template at the end of the manual for construction details, or purchase one from the Grizzly catalog. See **Figure 1**.



Figure 1. Push Stick

Zero Clearance Table Inserts

Ideal for use when ripping thin strips or making bevel cuts, these prevent tearout and jammed blades by supporting material close to the blade. Use the standard table insert as a template when creating additional inserts from wood or plywood. Blade slot inserts can be custom cut for specific blade angles by raising the running blade into an uncut insert at the angle you desire. Be sure to make an additional slot for the blade splitter. Grizzly also carries a wide selection of table inserts in the Grizzly catalog. Be sure to hold the insert firmly in place with a piece of wood when creating slots. Never hold the table insert with your hand while cutting new slots. See **Figure 2**.



Figure 2. Zero Clearance Table Inserts

Push Paddles

Push paddles provide added leverage and support when ripping or crosscutting wide workpieces. Grizzly offers a number of push paddles in the Grizzly catalog. See **Figure 3**.



Figure 3. Push Paddles

Featherboard

Easily made from scrap stock, featherboards provide an added degree of protection against kickback. To make a featherboard, cut a 30-40° angle at one end of the board and make a number of end cuts at approximately ¼" apart and 2" to 3" deep. Grizzly also offers a number of featherboards in the Grizzly catalog. See **Figure 4**.

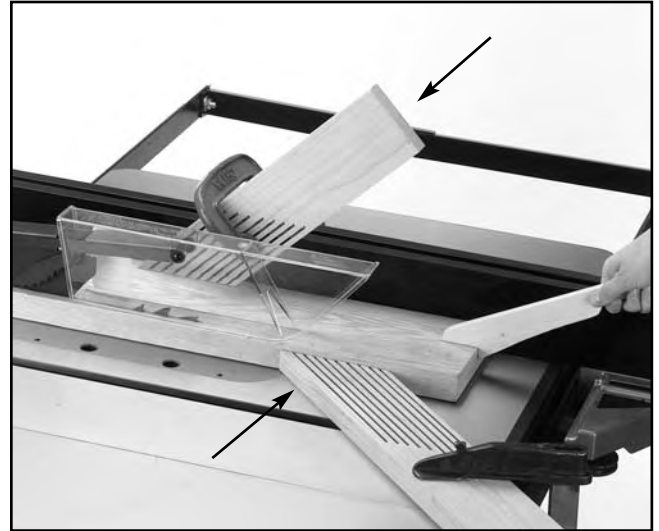

Figure 4. Featherboard



Common Definitions, Terms and Phrases

The following is a list of common definitions, terms and phrases used throughout this manual as they relate to this table saw and woodworking in general. It is important that you read and become familiar with them before assembling, adjusting or operating this machine. Your safety is **VERY** important to us at Grizzly!

Arbor: Metal shaft extending from the drive mechanism, to which the cutting blade is attached.

Bevel Edge Cut: Tilting the saw arbor and blade to an angle between 0° and 45° to perform an angled cutting operation.

Blade Guard: Metal or plastic mechanism that mounts over the saw blade to prevent accidental contact with the cutting edge.

Crosscut: Table saw operation in which the miter gauge is used to cut across the grain of a piece of wood.

Dado Blade: Blade or set of blades that attach to the arbor and are used for cutting grooves and rabbets.

Dado Cut: Table saw operation that uses a dado blade to cut a flat bottomed groove into the face of wood stock.

Featherboard: Safety device used to keep a board against the rip fence or table. Allows operator to keep hands away from the saw blade.

Kerf: The resulting cut or gap made by a saw blade.

Kickback: A condition in which the wood is thrown back towards an operator at a high rate of speed.

Miter Gauge: A component that controls the wood stock movement while performing a crosscut. Allows for variation of angle cuts such as miter cuts used on a picture frame.

Moulding Head: A cutterhead attached to the arbor. Accepts interchangeable moulding knives for profile cutting. We DO NOT recommend the use of a moulding head as they require advanced skills in their operation.

Parallel: Being an equal distance apart at every point. i.e. the rip fence face is parallel to the side face of the saw blade.

Non-Thru Cut: A sawing operation that requires the removal of the blade guard and splitter. Dado and rabbet cuts are considered Non-Thru Cuts because the blade does not protrude above the top face of the wood stock. Always remember to reinstall the blade guard and splitter after performing a non-thru cut.

Perpendicular: Intersecting and forming right angles; at right angles to the vertical and horizontal planes. i.e. the blade is perpendicular to the table surface.

Push Paddle: Safety aid used to push a piece of wood stock through a cutting operation.

Push Stick: Safety aid used to push a piece of wood stock through a cutting operation. Usually used when rip cutting.

Rabbet: Cutting operation that creates an L-shaped channel along the edge of wood stock.

Splitter: Metal plate attached to the back of the blade guard that maintains the kerf opening in the wood when performing a cutting operation.

Standard Kerf: 1/8" gap made with a standard blade.

Straightedge: A tool used to check the flatness, parallelness, or consistency of a surface(s).

Thru-Sawing: A sawing operation where the wood stock thickness is completely sawn through. Proper blade height usually allows 1/4" of the top of the blade to extend above the wood stock.

Thin Kerf: 3/32" gap made with a thin kerf blade.

Rip Cut: A cut made along grain of the wood.

Sacrificial Fence: A piece of wood attached to the face of the rip fence that is designed to extend the fence face away from the metal portion of the fence. Used primarily when making rabbet cuts with a dado blade.

SECTION 2: CIRCUIT REQUIREMENTS

220V Single-Phase

G7209 Only:

The Model G7209 has a 5 H.P., 3450 R.P.M. motor which requires a 220V single-phase circuit. The cord set included does not have a plug, as the style of plug you require will depend upon the type of service you currently have or plan to install. The motor will safely draw about 30 amps at 220V under load. If you operate the G7209 on any circuit that is already close to its capacity, it might blow a fuse or trip a circuit breaker. However, if an unusual load does not exist, and power failure still occurs, have the circuit inspected by a qualified electrician.

In preparing to connect the Model G7209 to your existing or new circuit, it will be necessary to connect a plug that matches your 220V receptacle. If you will be installing a new receptacle and plug, we recommend using a NEMA-style 6L-30 plug and outlet shown in **Figure 5**.

The Model G7209 should be fused at 30 amps. Fusing at amperage ratings higher than 30 amps will not adequately protect the circuit.

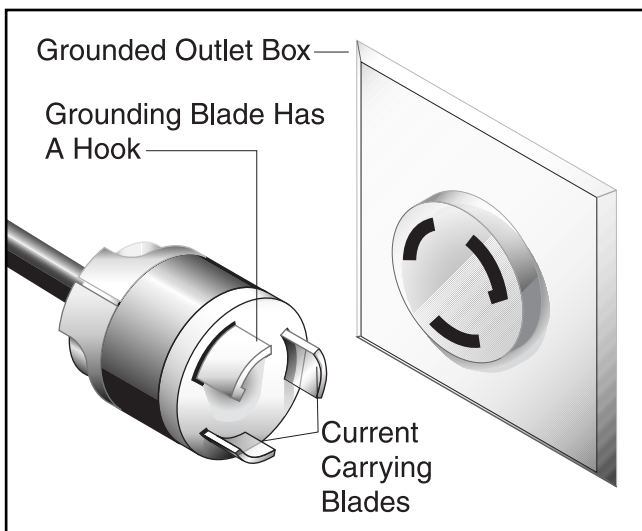

Figure 5. 220V Single-Phase



220V Three-Phase

G7210 Only:

The Model G7210 has a 7½ H.P., 3450 R.P.M. motor which requires a 220V 3-phase circuit. The cord set enclosed does not have a plug, as the style of plug you require will depend upon the type of service you currently have or plan to install. The motor will safely draw about 22 amps at 220V under load. If you operate the G7210 on any circuit that is already close to its capacity, it might blow a fuse or trip a circuit breaker. However, if an unusual load does not exist and power failure still occurs, have the circuit inspected by a qualified electrician.

In preparing to connect the Model G7210 to your existing or new circuit, it will be necessary to connect a plug that matches your 220V receptacle. If you will be installing a new receptacle and plug, we recommend using a HBL2711 30 A plug and outlet shown in **Figure 6**.

The Model G7210 should be fused at 30 amps. Fusing at amperage ratings higher than 30 amps will not adequately protect the circuit.

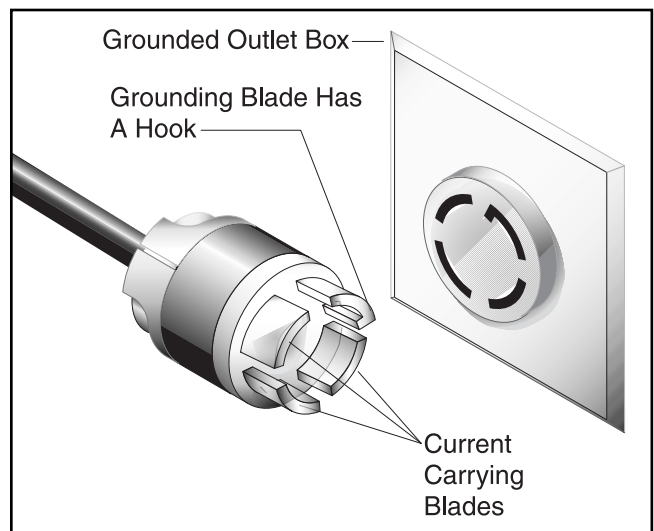

Figure 6. 220V 3-Phase



Grounding

In the event of a malfunction or breakdown, grounding provides a path of least resistance for electric current to reduce the risk of electric shock. This tool is equipped with an electric cord having an equipment-grounding conductor which must be properly connected to a grounding plug. The plug must be plugged into a matching outlet that is properly installed and grounded in accordance with all local codes and ordinances.

Improper connections of the electrical-grounding conductor can result in risk of electric shock. The conductor with green or green and yellow striped insulation is the electrical-grounding conductor. If repair or replacement of the electric cord or plug is necessary, do not connect the equipment grounding conductor to a live terminal.

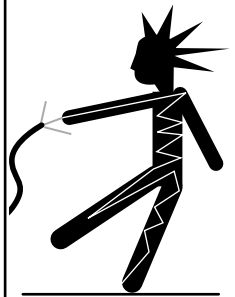
| | |
|--|--|
|  | <p>⚠ WARNING</p> <p>This equipment must be grounded. Verify that any existing electrical outlet and circuit you intend to plug into is actually grounded. Under no circumstances should the grounding pin from any three-pronged plug be removed. Serious injury may occur.</p> |
|--|--|



Extension Cords

We do not recommend the use of extension cords on 220V equipment. It is much better to arrange the placement of your equipment and the installed wiring to eliminate the need for extension cords. Should it be necessary to use an extension make sure the cord is rated Hard Service (grade S) or better. Refer to the chart in **Section 1: Safety** to determine the minimum gauge for the extension cord. The extension cord must also contain a ground wire and plug pin. Always repair or replace extension cords when they become worn or damaged.



Wiring Diagram

A wiring diagram is provided at the back of this manual should it be necessary to repair or revise the wiring. Always utilize a qualified electrician when doing any electrical work on this equipment.

⚠ CAUTION

We have covered some basic electrical requirements for the safe operation of your machine. These requirements are not necessarily comprehensive. You must be sure that your particular electrical configuration complies with local and state codes. Ensure compliance by checking with your local municipality or a licensed electrician.



SECTION 3: INTRODUCTION

Commentary

We are proud to offer the Grizzly Model G7209/10 14" Table Saw. The Model G7209/10 is part of a growing Grizzly family of fine woodworking machinery. When used according to the guidelines set forth in this manual, you can expect years of trouble-free, enjoyable operation and proof of Grizzly's commitment to customer satisfaction.

The Model G7209/10 is an industrial grade table saw intended for professional use. Features include cast iron trunnions, 4" dust port, quadruple V-belt drive, cam lever fence, magnetic switch, and a 5 H.P., 220V, single-phase motor (7½ H.P., 220V, 3-phase motor for G7210).

All running parts operate on shielded ball bearings and require no maintenance for the life of the bearings. We also offer many accessories for the table saws including blades, outfeed rollers, a sliding table and a mobile base. Please refer to our current catalog for prices and ordering information.

We are also pleased to provide this manual with the Model G7209/10. It was written to guide you through assembly, review safety considerations, and cover general operating procedures. It represents our effort to produce the best documentation possible. If you have any comments regarding this manual, please write to us at the address below:

Grizzly Industrial, Inc.
c/o Technical Documentation
P.O. Box 2069
Bellingham, WA 98227-2069

Most importantly, we stand behind our machines. If you have any service questions or parts requests, please call or write us at the location listed below:

Grizzly Industrial, Inc.
2406 Reach Road
Williamsport, PA 17701
Phone: (570) 546-9663
Fax: (800) 438-5901
E-Mail: techsupport@grizzly.com
Web Site: <http://www.grizzly.com>

After Fall 2001:

Grizzly Industrial, Inc.
1203 Lycoming Circle
Pennsdale, PA 17756

The specifications, drawings, and photographs illustrated in this manual represent the Model G7209/10 as supplied when the manual was prepared. However, owing to Grizzly's policy of continuous improvement, changes may be made at any time with no obligation on the part of Grizzly. Whenever possible, though, we send manual updates to all owners of a particular tool or machine. Should you receive one, we urge you to insert the new information with the old and keep it for reference.

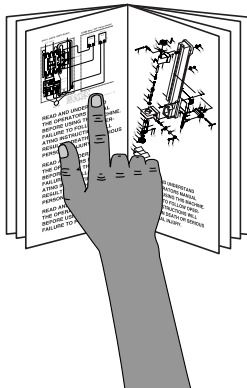
| | |
|--|---|
|  | <p>⚠ WARNING</p> <p>Read the manual before assembly and operation. Become familiar with the machine and it's operation before beginning any work. Serious personal injury may result if safety or operational information is not understood or followed.</p> |
|--|---|





Unpacking

The Model G7209/10 is shipped from the manufacturer in a carefully packed carton. If you discover the machine is damaged after you've signed for delivery, immediately call Customer Service for advice.

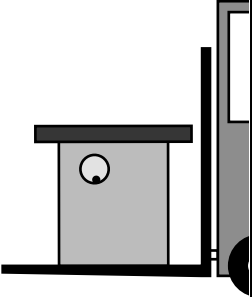
When you are completely satisfied with the condition of your shipment, you should inventory its parts.

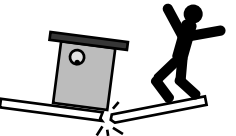
| | |
|---|--|
|  | <p>⚠ WARNING</p> <p>The G7209/10 is a heavy machine, 1000 lbs. shipping weight. DO NOT over-exert yourself while unpacking or moving your machine – you will need assistance and power equipment. Serious personal injury may occur if safe moving methods are not followed.</p> |
|---|--|

| | |
|---|--|
|  | <p>⚠ WARNING</p> <p>Make sure floor structure is capable of supporting the combined weight of the machine parts and people.</p> |
|---|--|

| | |
|---|--|
|  | <p>⚠ CAUTION</p> <p>Some metal parts may have sharp edges on them after they are formed. Please examine the edges of all metal parts before handling them. Failure to do so could result in injury.</p> |
|---|--|



Piece Inventory

After all the parts have been removed from their containers, you should have:

- Table Saw Unit
- Miter Gauge
- Extension Wings (2)
- Fence Assembly
- Splitter/Guard Assembly
- Dust Port
- Hardware Bag

In the event that any nonproprietary parts are missing (e.g. a nut or a washer), we would be glad to replace them; or for the sake of expediency, replacements can be obtained at your local hardware store.



Figure 7. G7209/10 cabinet stand.





Figure 7A. G7209/10 component layout.



Clean up

The table and other unpainted parts of the Model G7209/10 are coated with a waxy grease that protects them from corrosion during shipment. Clean this grease off with a solvent cleaner or citrus-based degreaser such as Grizzly's G7895 Degreaser. Do not use chlorine-based solvents – if you happen to splash some onto a painted surface, you'll ruin the finish.

| | |
|---|---|
|  | <p>⚠ WARNING Do not use gasoline or other petroleum-based solvents. They have low flash points which make them extremely flammable. A risk of explosion and burning exists if these products are used. Serious personal injury may occur if this warning is ignored.</p> |
|---|---|

| | |
|---|--|
|  | <p>⚠ WARNING Do not smoke while using solvents. A risk of explosion or fire exists and may result in serious personal injury.</p> |
|---|--|

| | |
|---|---|
|  | <p>⚠ CAUTION Many of the solvents commonly used to clean machinery can be toxic when inhaled or ingested. Always work in well-ventilated areas far from potential ignition sources when dealing with solvents. Use care when disposing of waste rags and towels to be sure they do not create fire or environmental hazards.</p> |
|---|---|



Site Considerations

- 1. Floor Load:** Your Model G7209/10 represents a large weight load in a small footprint. Most commercial floors are suitable for the saw. Some residential floors may require additional bracing to support both machine and operator.
- 2. Working Clearances:** Consider existing and anticipated needs, size of material to be processed through each machine, and space for auxiliary stands, work table or other machinery when establishing a location for your table saw.
- 3. Lighting and Outlets:** Lighting should be bright enough to eliminate shadows and prevent eye strain. Electrical circuits should be dedicated or large enough to handle amperage requirements. Outlets should be located near each machine so power or extension cords are clear of high-traffic areas. Observe local electrical codes for proper installation of new lighting, outlets, or circuits.

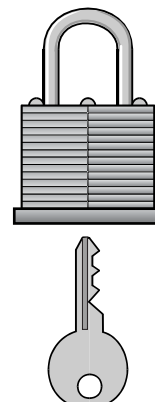
| | |
|--|--|
|  | <p>⚠ CAUTION Make your shop “child safe.” Ensure that your workplace is inaccessible to youngsters by closing and locking all entrances when you are away. Never allow visitors in your shop when assembling, adjusting or operating equipment.</p> |
|--|--|



SECTION 4: ASSEMBLY

Beginning Assembly

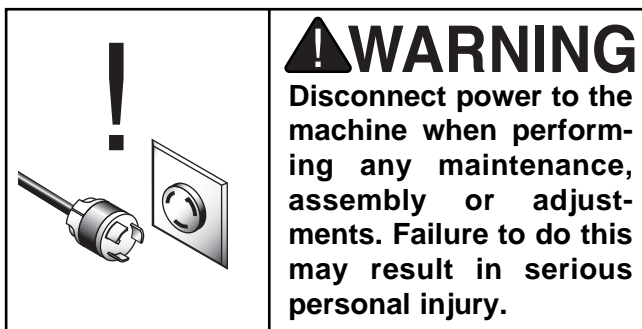
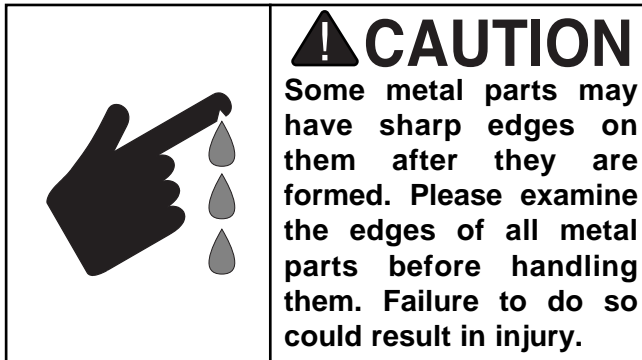

Most of your Model G7209/10 has been assembled at the factory, but some parts must be assembled or installed after delivery. We have organized the assembly process into steps. Please follow along in the order presented here.

TOOLS REQUIRED: You will need a high quality square, a long straightedge, 10mm, 12mm, 14mm open end wrenches and a 3mm Allen® wrench.



Extension Wings

Inspect the extension wings for burrs or foreign material that may inhibit assembly. The mating edges of the wings and table must be clean, smooth, and flat. Use a wire brush or file if necessary to clean up the edges.

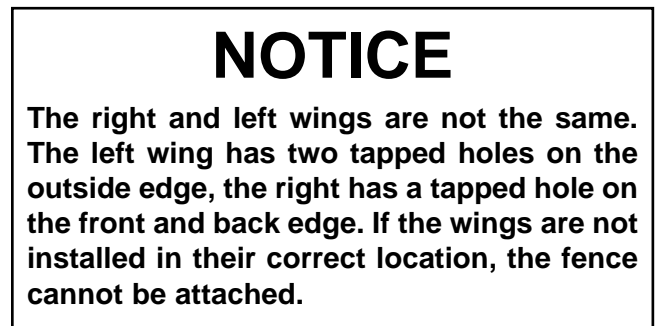

1. Attach the left wing to the table using the three hex head bolts and flat washers provided. Adjust the wing reasonably flush with the table. Do not tighten the bolts.
2. Attach the right wing to the table using the three hex head bolts and flat washers provided. Adjust the wing reasonably flush with the table. Do not tighten the bolts.
3. Align the top of the wing flush with the table top directly above the front bolt, and tighten the front bolt. The front edge of the extension wing should also be flush with the front edge of the table.
4. Raise or lower the rear of the extension wing until the middle of the wing is flush with the table top. Tighten the middle bolt.

5. Raise or lower the rear of the wing until the wing and table are flush. Tighten the bolt. Any adjustment at this point should be minimal.
6. Check flushness at the front bolt and readjust if necessary.
7. Repeat **Steps 3-4** for the other extension wing.
8. Now, check the alignment of the table and both wings with a straightedge. The straightedge should run flat across both wings and the table top. If the straightedge contacts both wings and the table evenly, you are finished with this section. If it does not, continue to **Step 9**.
9. If the extension wings tilt up or down at the outside edges, remove the wings and shim them with masking tape. See **Figure 7**.
 - a. If the wings tilt down, stick layers of masking tape under each bolt near the bottom edge of the wing and retighten.
 - b. If the wing tilts up, stick layers of masking tape above each bolt near the top edge of the wing and retighten. Allow tape to extend above table surface and trim with a sharp knife after final assembly.
10. Replace the wings and check again.



Figure 7. Using tape to shim for wing alignment.

Fence Rails

1. Locate the rear fence rail (the shorter of the two rails).
2. Attach the rear rail to the table top using the spacers, hex bolts and lock washers supplied. See **Figure 8**. Using a combination square set at $\frac{15}{32}$ ", place at the edge of the table, and adjust the rail so it is consistently $\frac{15}{32}$ " below the top of the table.

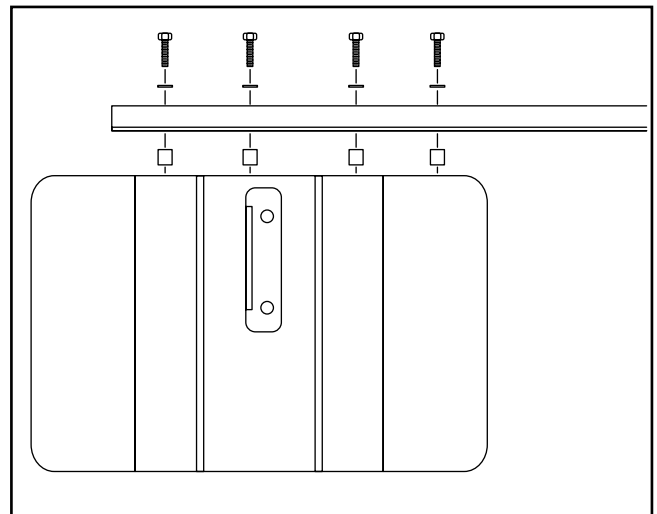

Figure 8. Rear rail attachment procedure.

3. Attach the front rail to the table top using the hex socket flathead screws supplied. See **Figure 9**. Place a combination square set at $\frac{25}{32}$ ", at the edge of the table, and adjust the rail so it is consistently $\frac{25}{32}$ " below the top of the table.

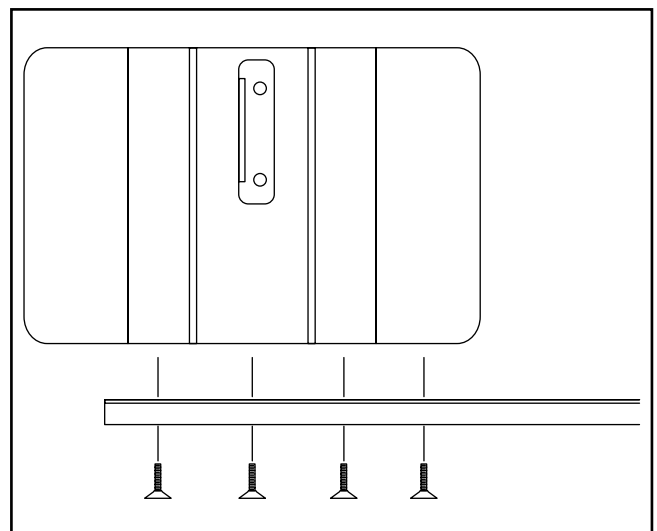

Figure 9. Front rail attachment procedure.



4. Attach the square fence tube to the front rail using the hex bolts and lock washers supplied. See **Figure 10A**.
5. Attach the fence and slide across the length of the rails to ensure smooth, accurate fence movement.

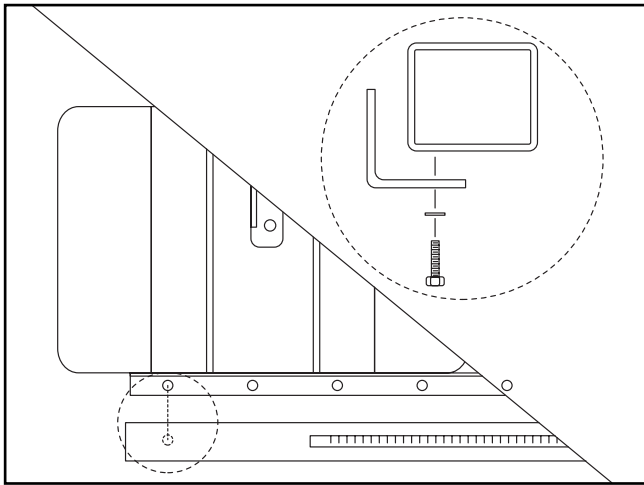

Figure 10A. Attaching fence tube to front rail.



Guard Support Shaft

To install the guard support shaft:

1. Push the threaded end of the shaft through the hole in the back of the saw (**Figure 10B**) until the shoulder on the shaft stops it.
2. Secure with the hex nut and washer.

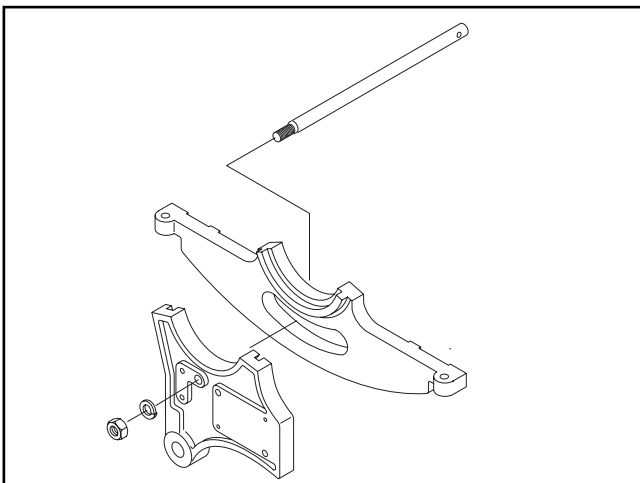

FIGURE 10B. Attaching guard support shaft.



Saw Blade

!WARNING

The saw blade is extremely sharp. Use extra care when handling the blade or working near it. Serious injury is possible.

Please review this section even if your saw blade came pre-installed. To install the blade:

1. Remove the table insert to gain access to the arbor.
2. Remove the nut and outer arbor flange from the arbor.
3. Place the blade on the arbor, making sure that it seats firmly against the inner arbor flange. Ensure that the top blade teeth are facing the front of the saw.
4. Replace the outer arbor flange and rethread the arbor nut.
5. Hand tighten nut and snug with the wrench included with the saw. **DO NOT** overtighten.

IMPORTANT: Make sure the blade is installed with the teeth facing the front of the saw.



Motor Bracket



Figure 10C. Remove motor bracket.

Your saw comes from the factory with a red motor bracket designed to protect the motor assembly during shipping. Remove the bracket shown in **Figure 10C**.



Blade Guard/Splitter

1. Slip the blade guard/splitter over the mounting bolts as shown in **Figure 12**. The washers should be between the bolt head and the slots. Tighten the bolts to secure the blade guard/splitter.

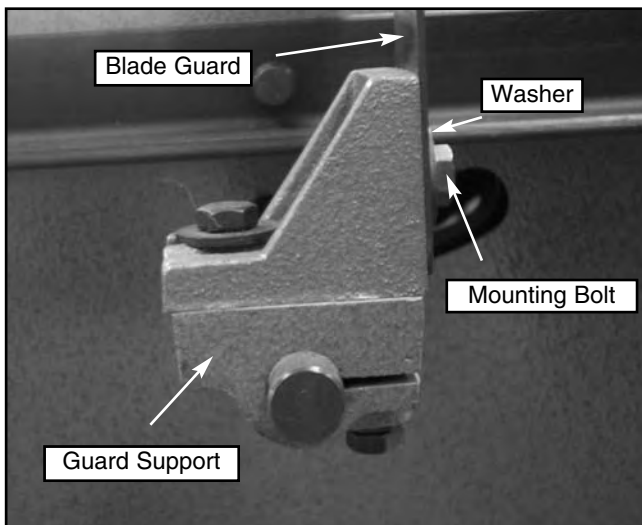

Figure 12. Blade guard and splitter in place.

2. Set a machinist's square against the face of the blade guard/splitter. Slightly rotate the rear bracket to adjust the face of the blade guard perpendicular to the table top as shown in **Figure 13**.



Figure 13. Guard assembly square to table.

!WARNING

The saw blade is extremely sharp. Use extra care when handling the blade or working near it. Serious injury is possible.

3. Next, set a straightedge against the face of the saw blade and the blade guard/splitter as shown in **Figure 14**. If the blade guard/splitter is properly aligned, please skip ahead to "Table Insert"; otherwise, continue with the next step.

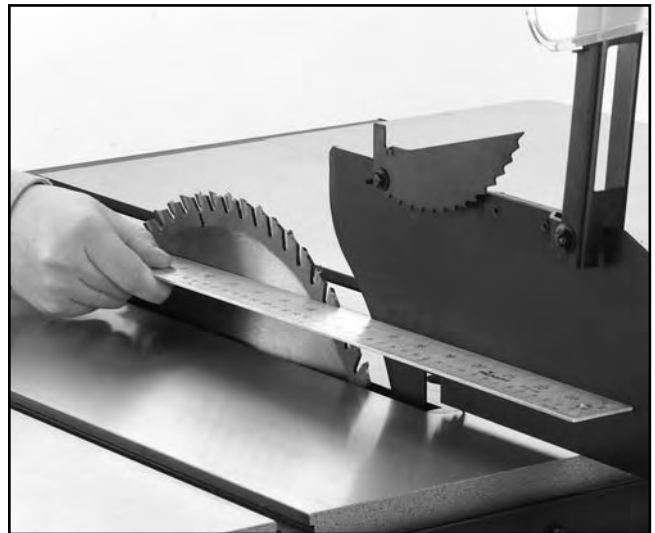

Figure 14. Guard in line with blade.

4. If the blade guard/splitter is to the right of the blade as shown in **Figure 15**, simply add washers between the splitter and front mounting bracket, and adjust the rear splitter support as shown in **Figure 16**.

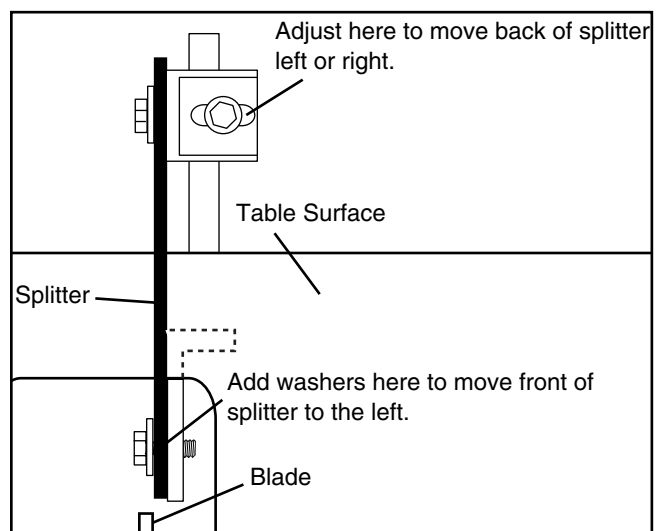

Figure 15. Improper splitter/blade alignment.

G7209/10 14" Table Saw

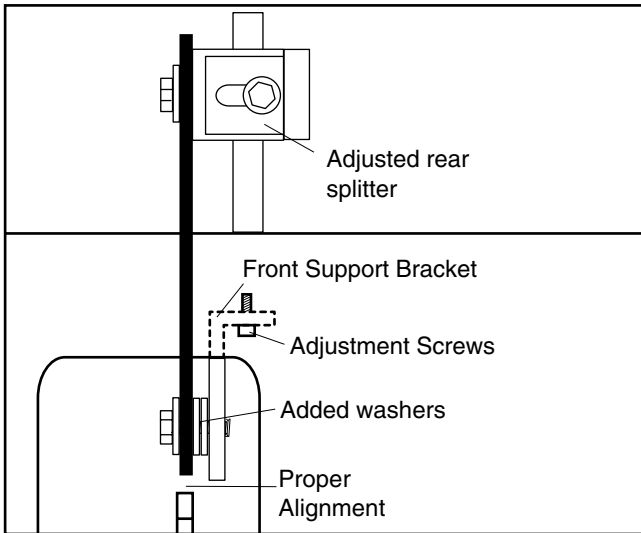

Figure 16. Proper splitter/blade alignment.

5. Recheck guard alignment to the blade and to the table top. Adjust as necessary and tighten all the bolts before use. If the blade guard is properly aligned, please skip ahead to **Step 10**; otherwise, continue with the next step.
6. If the splitter is positioned to the left of the blade, alignment cannot be achieved by washer placement. Adjustment of the front support bracket is required. See **Figure 16**. Loosen the (2) adjustment screws and move left or right.
7. If this adjustment does not allow enough movement of the splitter, remove the table and wings, and set them to one side.

| | |
|--|---|
| | <p>! WARNING</p> <p>The table and wings represent a very heavy load. DO NOT over-exert yourself while lifting or moving the table and wings – get assistance.</p> |
|--|---|

8. The arbor bracket and motor pulley needs adjusting. Loosen the cap screw and the setscrew as shown in **Figure 17**, and slowly slide the arbor bracket towards the end of the shaft. Only move the arbor bracket a distance equal to the amount of misalignment between the blade and splitter, or a little more. You can always adjust the splitter back to the left with washers. Tighten the cap screw and setscrew securely.

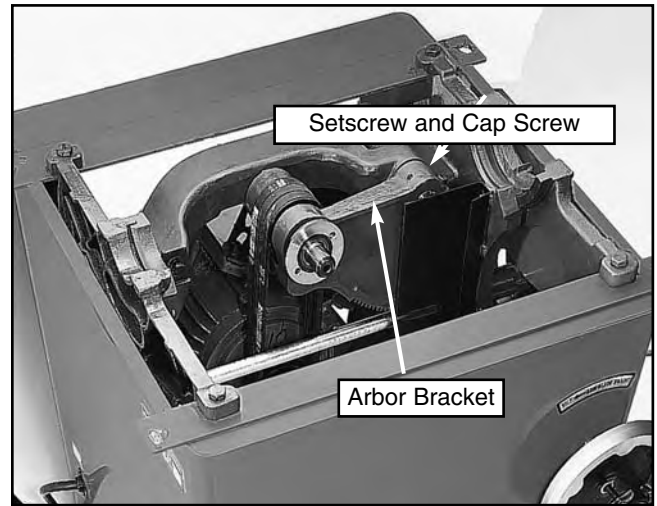
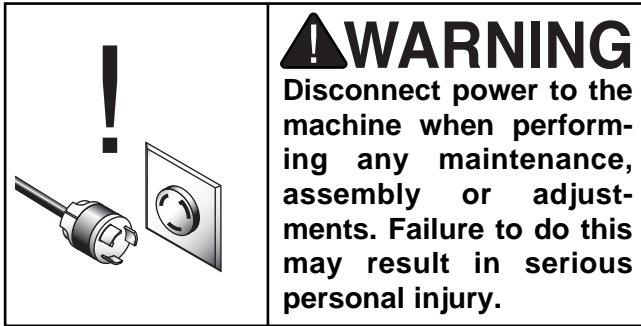

Figure 17.

9. Moving the arbor bracket moves the V-belts and pulleys out of alignment, so adjustment of the motor pulley is required. Simply loosen the setscrew and slowly slide the pulley towards the end of the motor shaft. Once the V-belts are back into alignment, tighten the setscrew securely.
10. Recheck guard alignment to the blade and to the table top. Adjust as necessary and tighten down all the bolts before use. If the blade guard is properly aligned, reattach the table, making sure there is adequate blade clearance through all blade adjustments.
11. Adjust the blade to 45° and raise and lower it through the full range. Readjust blade to 90° and raise and lower it through the full range. There should be no contact between the base and the table insert, or any other part of the saw. If it does, repeat **Steps 7-9**.



Table Insert



The table insert provides access to the blade and arbor when removed. When in place, the insert provides support for materials being cut.

1. Disconnect the power cord from the outlet.
2. Ensure that all four setscrews are firmly in contact with the table casting.
3. Using a 6mm hex wrench, raise or lower each of the four setscrews until the insert is flush with the table top. See **Figure 18**.
4. Now make sure the blade will not come into contact with table insert. Position the blade at 90°, then raise and lower the blade through its full range of motion. Also rotate the blade while doing this, making sure that the blade never contacts any part of the table insert. Do the same with the blade in the 45° position. Wear leather gloves while rotating the blade to prevent being cut.
5. Be sure to review **Section 5: Adjustments, "Blade Alignment,"** before operating the saw.

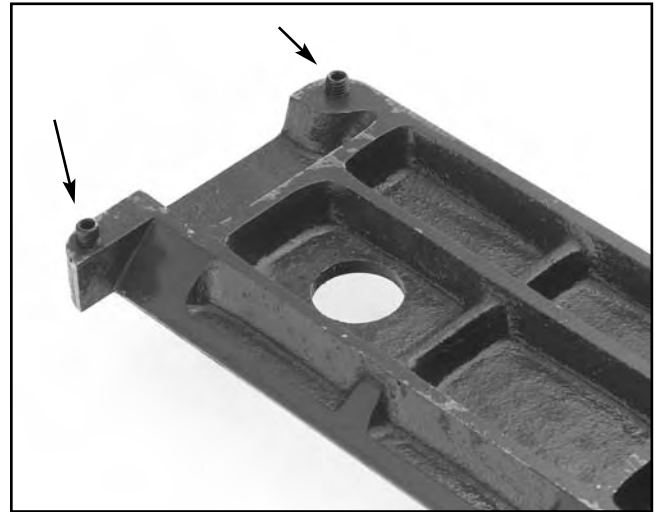
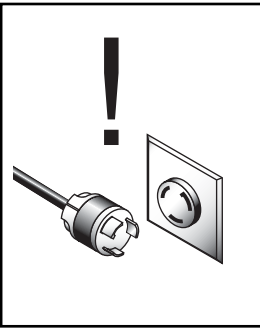

Figure 18. Setscrew on each corner of insert.



SECTION 5: ADJUSTMENTS



⚠️ WARNING
Disconnect power to the machine when performing any maintenance, assembly or adjustments. Failure to do this may result in serious personal injury.

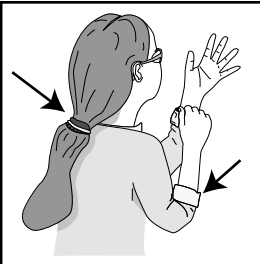

⚠️ WARNING
Keep loose clothing rolled up and out of the way of machinery and keep hair pulled back.



⚠️ WARNING
Wear safety glasses during the entire adjustment process. Failure to comply may result in serious personal injury.

Blade Height

When preparing to operate your table saw, you should adjust the blade height to approximately $\frac{1}{4}$ " above the surface of the material you plan on cutting. The handwheel at the front of the saw adjusts blade height. To adjust blade height:

1. Loosen the locking knob at the center of the blade height handwheel.
2. Using a sample of the material you plan on cutting as a gauge, turn the handwheel until the blade reaches its intended height.
3. Retighten the locking knob.
4. Recheck your blade height with the sample material and readjust, if necessary.



Blade Tilt

1. Set your blade angle at zero as shown on the angle indicator on the front of the saw and raise the blade several inches above the table.
2. Place a machinist's square flat on the table and slide it along side the blade. The square should contact the blade evenly from bottom to top. Make sure that a blade tooth does not obstruct the square's movement.
3. Adjust the handwheel until the square is flush with the blade. Loosen the tilt indicator arrow, set to zero, and retighten. Loosen and adjust the stop bolt on the left side of the front trunnion to allow a 90° stop point. See **Figure 20**.
4. Turn the blade angle handwheel until the angle indicator points at the desired angle.
5. Tighten the handwheel locking knob.
6. Repeat **Steps 1-6** for setting the blade to 45° and adjust the 45° stop bolt on the right side of the front trunnion. See **Figure 20**. Use the 45° side of a combo square or a bevel gauge set at 45° .

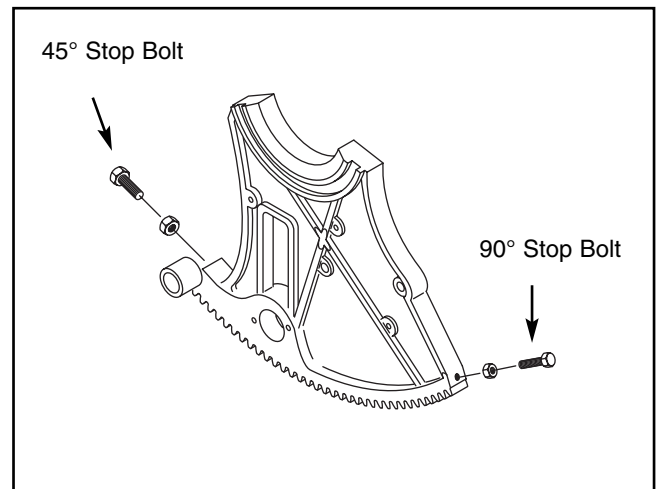

Figure 20. 90° and 45° stop bolts.



Miter Slot to Blade

Your table saw will give the best results if the miter slot and rip fence are adjusted parallel to the blade. If they are not exactly parallel, your cuts and finished work will be lower in quality, but more important, it increases the risk of kickback. Take the time to adjust your table saw properly. A few minutes now will be time well spent.

1. **Disconnect the power cord from the outlet.** Use a piece of tape to mark the blade in the gullet between two (2) teeth closest to the table.
2. Use an adjustable square to measure the distance from the mark on the blade to the edge of the miter slot. See **Figure 21**.
3. Rotate the blade 180°.
4. Measure the distance from the mark on the blade to the edge of the miter slot. See **Figure 22**.



Figure 21. Adjusting blade to miter slot.

5. The difference between the two measurements must be equal to or less than $\frac{1}{64}$ ".
6. If the difference is greater than $\frac{1}{64}$ ", loosen the four (4) table mounting bolts as seen in **Figure 23** and adjust the table slightly. Repeat **Steps 1-5** until satisfactory. Do not forget to tighten the table mounting bolts when finished.

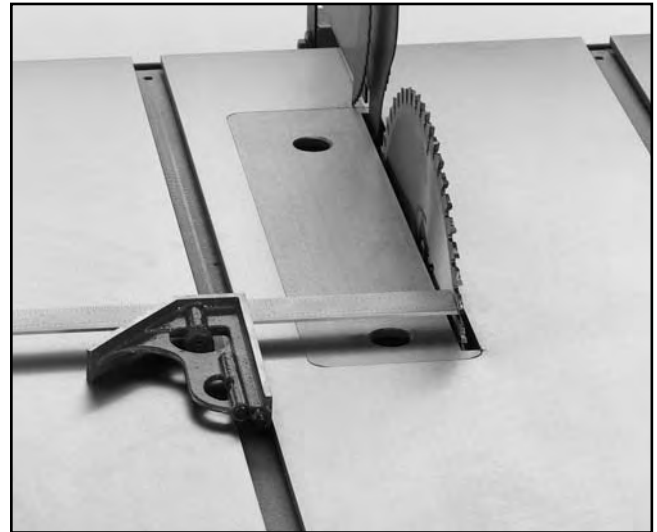

Figure 22. Adjusting blade to miter slot after rotating blade 180° and sliding square down miter slot.

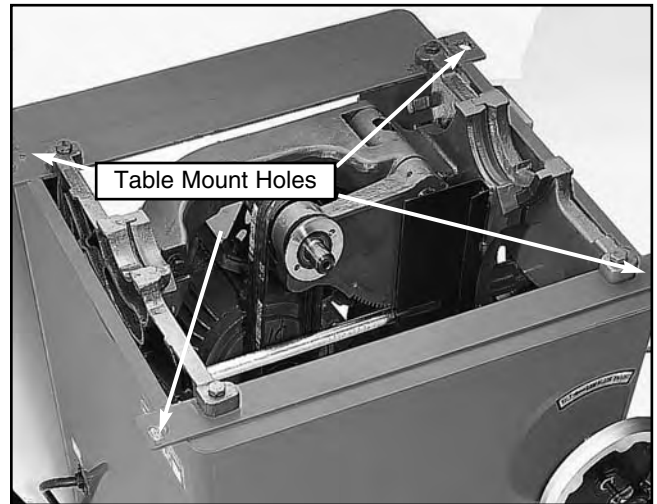

Figure 23. Table mounting bolt holes.

7. Now check to see if the blade remains parallel to the miter slot when tilted to 45°.
8. Tilt the blade to 45° and repeat **Steps 1-5**. If the blade is still parallel to the miter slot, continue on to the "Miter Gauge" instructions. Otherwise, continue with the next step.
9. If the blade was parallel to the miter slot at 90° but not at 45°, the table will need to be shimmed with metal shim stock. The shims are placed under the table over each of the four table mounting bolts as shown in **Figure 23**.

!WARNING

The saw blade is dangerously sharp. Use extra care when handling the blade or working near it. Serious injury is possible.

10. Refer to **Figures 24 and 25**, for shim placement. If the distance of A is longer than B, shim(s) will need to be placed under corners #1 and #2. If the distance of B is longer than A, shim(s) will need to be placed under corners #3 and #4. Very thin shim stock works well, just make sure they are all the same thickness, and you put an equal number under each of the two corners.
11. Tighten down one bolt a small amount and then move on to each of the others, tightening each down the same amount. Continue to rotate through the bolts, tightening them a little each time until they are all secure.
12. Now recheck the blade to miter slot at 90° and 45° by repeating **Steps 1-5**. If the distance of A and B are equal to or less than 1/64" at both 90° and 45°, continue to the "Miter Gauge" instructions. If the distances are still off by more than 1/64", repeat **Steps 9-12**.
13. Once you feel you have the miter slot adjusted to the blade, recheck all measurements and be sure the table mounting bolts are secure. Repeat **Step 10** in **Section 4: Assembly**, "Blade Guard/Splitter. Also, if you ever remove the table in the future, be sure to make note of shim placements and reassemble exactly how it came apart.

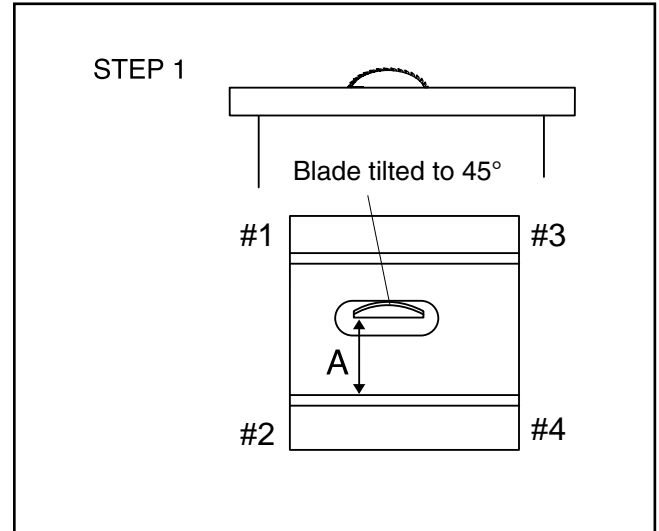

Figure 24.

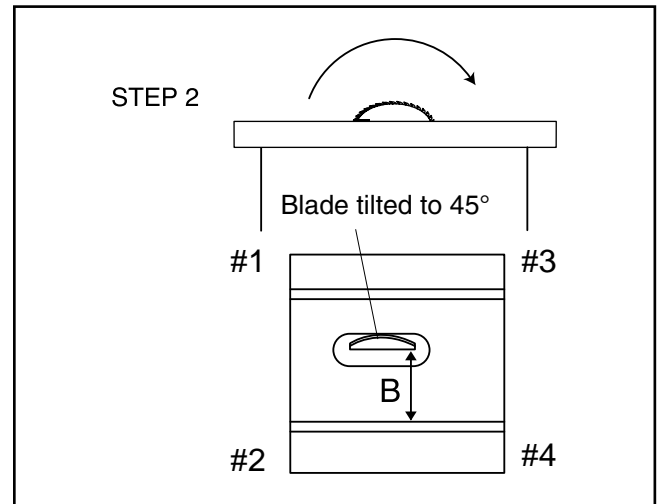

Figure 25.



Miter Gauge

To adjust the miter gauge so it is perpendicular to the saw blade:

1. Loosen the lock knob on the miter gauge and place a square against the face of the miter body and the blade.
2. Adjust the miter body until there is no space between the square and the blade. Tighten the lock knob.
3. Now loosen the setscrew on the left front side of the miter bar, adjust the pointer to 90° and tighten the setscrew.
4. To adjust to other angles, follow **Steps 1-3** using a protractor to set the angle.

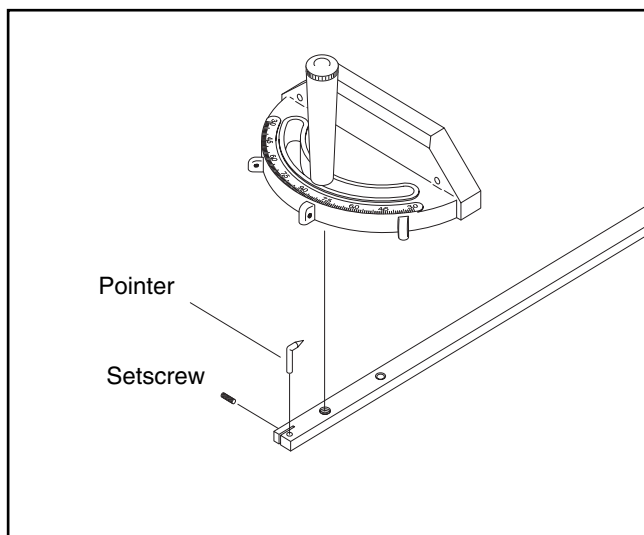

Figure 26.



Rip Fence

The rip fence included with your Model G7209/10 14" Table Saw is designed to provide excellent ripping accuracy when properly adjusted. There are three main adjustments to concern yourself with: square, parallelism and clamping pressure.

SQUARE

Place a machinist's square against the side of the fence. If the square does not remain flush against both the fence and the table, adjust the nylon screws on top of the bracket at the front of the fence until square. See **Figure 27**.

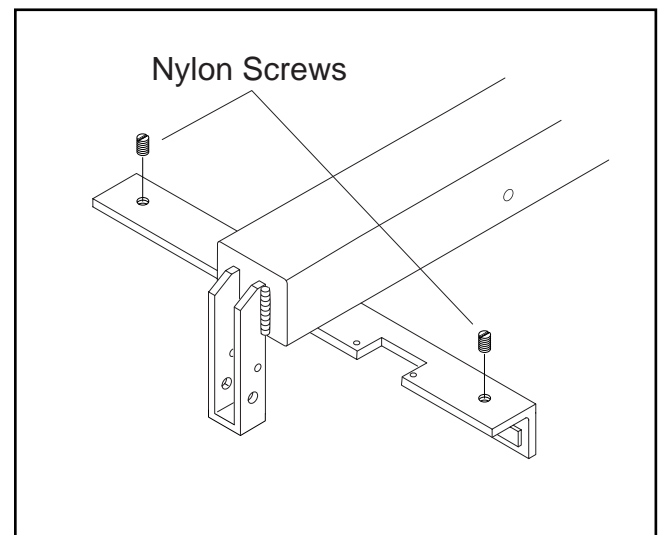

Figure 27.

CLAMPING PRESSURE

The fence-clamping mechanism has been adjusted at the factory to provide the right amount of clamping pressure to hold your fence securely. Should it eventually need adjustment:

1. Loosen the clamping arm.
2. Remove the fence from the saw and adjust the setscrews equally on the rear side of the front bracket as shown in **Figure 28**.
3. Replace the fence and check the clamping strength. Readjust until proper pressure is ensured.

Blade Alignment

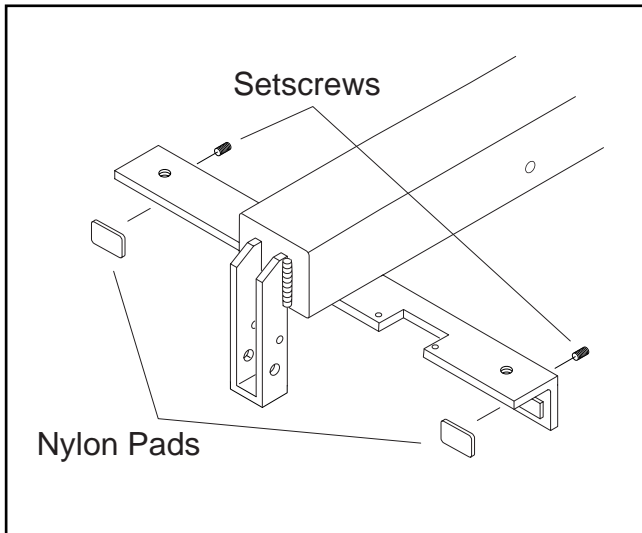

Figure 28.

PARALLELISM

Align the fence alongside the miter slot as shown in **Figure 29**, and lock it down. If the fence is not perfectly parallel to the miter slot:

1. Release the clamping mechanism.
2. Remove the fence from the saw and adjust the setscrews on the rear side of the front bracket as shown in **Figure 28**. Make VERY minor adjustments and recheck by reclamping the fence along the miter slot after each adjustment. Keep in mind that a small turn of the setscrew can make a large difference over the length of the fence. Be sure clamping pressure is still adequate.



Figure 29.



The blade position can be adjusted slightly in case it contacts the table insert when raised or tilted. This adjustment can be made by moving the table, the whole trunnion assembly, or by just moving the arbor bracket. Try adjusting by moving the table first as this is the easiest way. If that doesn't work, try adjusting the whole trunnion assembly. If that still doesn't work, try moving the arbor bracket.

To adjust the blade position by moving the table:

1. Disconnect plug from power source.
2. Loosen the four table mounting bolts.
3. Nudge the table to either the left or right depending on where the blade is hitting the saw. Tighten all mounting bolts.
4. If the blade is still contacting the insert, repeat **Steps 1-3**. Check all other adjustments.
5. Recheck the blade to miter slot adjustments, and adjust as necessary.

To adjust the blade position by moving the trunnion:

1. Disconnect plug from power source.

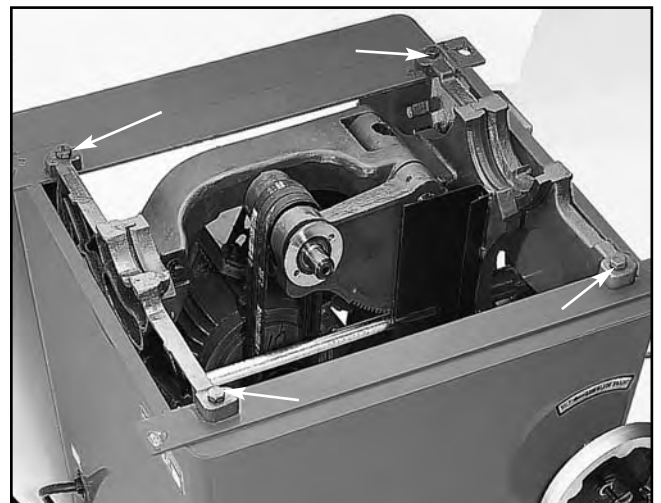

Figure 30A. Trunnion mounting bolts.



2. Remove the table and wings and set them to one side.
3. Loosen the four trunnion mounting bolts as shown in **Figure 30A**, and nudge to either the left or right depending on where the blade is hitting the saw.
4. Reattach the table, making sure there is adequate blade clearance through all blade adjustments. Recheck guard alignment to the blade and to the table top. Adjust as necessary and tighten down all the bolts before use.
5. If the blade is still contacting the insert, repeat **Steps 1-4**. Check all other adjustments.
6. Recheck the blade to miter slot adjustments, and adjust as necessary.

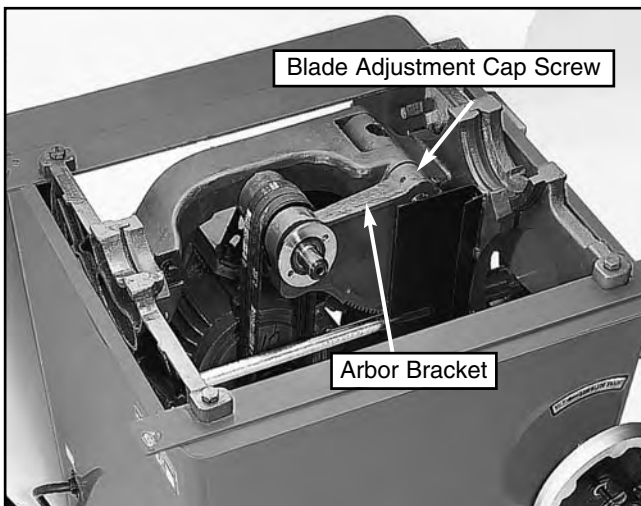

Figure 30B. Adjusting arbor bracket.

To adjust the blade position by moving the arbor bracket:

1. Disconnect plug from power source.
2. Remove the table and wings and set them to one side.
3. Loosen the blade adjustment cap screw shown in **Figure 30B**.
4. To adjust the arbor bracket, loosen the cap screw and the setscrew. Slowly slide the arbor bracket towards the end of the shaft.
5. Moving the arbor bracket moves the V-belts and pulleys out of alignment, so adjustment of the motor pulley is required. Simply loosen the setscrew and slowly slide the pulley towards the end of the motor shaft. Once the V-belts are back into alignment, tighten the setscrew securely.
6. Reattach the table, making sure there is adequate blade clearance through all blade adjustments. Recheck guard alignment to the blade and to the table top. Adjust as necessary and tighten down all the bolts before use.
7. If the blade is still contacting the insert, repeat **Steps 1-6**. Check all other adjustments.
8. Recheck the blade to miter slot adjustments, and adjust as necessary.



SECTION 6: OPERATIONS

Pre-Run Check

Before you begin to use your Model G7209/10 14" Table Saw, you should give it a thorough inspection. While making your inspection, ask yourself the following questions:

1. Are all the fasteners tight?
2. Is the blade mounted correctly?
3. Is the saw stable?
4. Is it wired properly?
5. Is your electrical system properly configured?
6. Have you checked your work piece for obvious defects?
7. Are the V-belts properly tensioned and the pulleys properly aligned?
8. Is the guard assembly installed and functional?
9. Have you checked the saw blade clearance when it is adjusted to varying angles and depths?
10. Have you read all warnings and directions regarding the operation of this machine?



Test Run

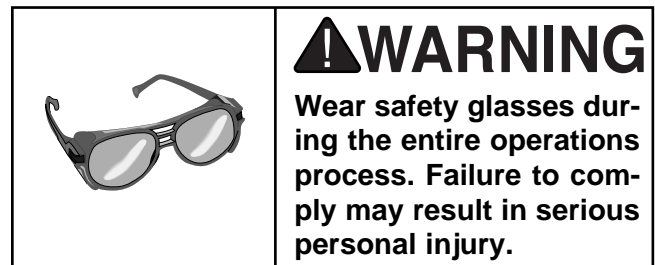
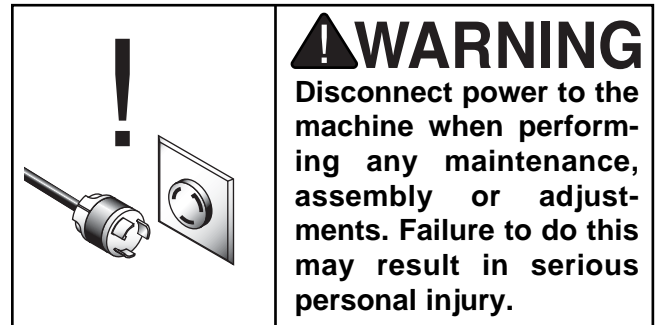

1. Face the table saw and stand to the left of the blade path.
2. With one finger on the START button and one finger on the STOP button, turn the saw on. Be ready to turn it off in case of mishap.
3. Watch and listen to the saw. Note whether there are any unusual sounds or excessive vibrations.

4. If anything appears abnormal, immediately turn off the saw and fix the problem. If a problem exists that is beyond the scope of this manual, call our service department.
5. If the saw is behaving normally, turn it off and prepare to make a cut according to the instructions outlined in the following sections.



Blade Selection

Choosing the correct blade for the job is essential for the safe and efficient use of your table saw. Ignoring this important step could result in damage to the saw and serious injury to the operator. Documented below are the most common saw blades and their uses.

1. **Rip Blade:** Used for cutting with the grain. Typically, 14" rip blades have between 30-40 teeth, a flat-top ground profile and large gullets to allow for large chip removal. See **Figure 31**.



Figure 31. Ripping blade.

2. **Cross-cut Blade:** Used for cutting across the grain. 14" cross-cut blades have between 60-80 teeth, alternate top bevel or steep alternate top bevel tooth profiles, small hook angle and a shallow gullet. See **Figure 32**.



Figure 32. Cross-cutting blade.

3. **Combination Blade:** Used for cutting with and across the grain. A compromise between a rip blade and a cross-cut blade, a 14" combination blade will typically have between 60-70 teeth, an alternate top bevel and flat or alternate top bevel and raker tooth profile. The teeth are arranged in groups of five. The gullets are small and shallow within the groups of five teeth, similar to a cross-cut blade; then large and deep between the groups, like a ripping blade. See **Figure 33**.



Figure 33. Combination blade.

4. **Plywood Blade:** Used for cutting plywood or veneers. A 14" plywood blade will have 80+ teeth, a steep alternate top bevel tooth profile and very shallow gullet. See **Figure 34**.



Figure 34. Plywood blade.

5. **Thin-kerf:** Most types of saw blades are available in a thin-kerf style. Used primarily to minimize stock wastage. It is recommended thin-kerf blades be used in conjunction with a blade stabilizer to reduce blade wobble. **Note:** Most blade guards/splitters are thicker than most thin-kerf blades. Make sure the stock will pass by the guard/splitter before beginning a cut.
6. **Dado Blades:** There are two types of dado blades: stack and wobble. Stack dados are expensive and time consuming to set up but leave a clean and smooth finish. Stack dados are used for fine furniture and cabinet making. Wobble dados are inexpensive and easy to set up, but leave a rough finish.
7. **Moulding Heads:** A moulding head is a cutterhead that attaches to the arbor and holds individual moulding knives. We do not recommend their use. They are very dangerous and required training beyond the scope of this manual.

This section on blade selection is by no means comprehensive. Always follow the saw blade manufacturer's recommendations to assure safe and efficient operation of your table saw.

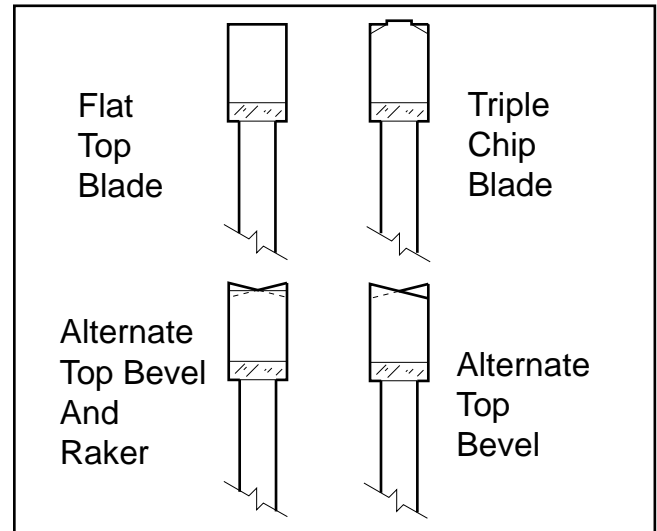

Figure 35. Various saw tooth cutting profiles.



Crosscutting

Crosscutting means cutting across the grain of the wood. In wood products without grain (i.e. MDF, particleboard) it simply means cutting across the width of the stock.

Crosscuts are made with the miter gauge. There are two miter gauge slots in the table top. Use the one that works best for the piece being crosscut. To make a crosscut using the miter gauge:

1. Inspect the board for soundness. You do not necessarily need a square edge to crosscut with accuracy.
2. Inspect the miter gauge. Is it properly set and tight? Move the rip fence completely out of the way.
3. Turn on the saw and allow it to come to full speed.
4. Hold the workpiece firmly against the face of the miter gauge and ease it into the blade. See **Figure 36**.
5. Turn off the saw and allow the blade to come to a full stop.



Figure 36. Cross-cut operation.



Ripping

Ripping means to cut with the grain of the wood. In other materials such as MDF or plywood, ripping simply means to cut lengthwise. To rip a board:

1. Inspect the board for soundness. You will need a straightedge to rip with accuracy. Your workpiece may need to be jointed flat before attempting to cut on the table saw.

WARNING

Never attempt to rip a board that does not have one perfectly straight edge on it. Always run the straight edge of the board against the rip fence. Failure to do this could result in kickback and serious personal injury.

2. Set the rip fence to the desired distance from the blade. **IF YOU ARE MAKING NARROW CUTS, USE A PUSH-STICK.** It is unsafe to put your hands close to the blade. A push-stick pattern has been included in this manual on **Page 45**, or you can purchase the G3445 or G1411 push stick from the Grizzly catalog. Use them to hold the workpiece against the table and fence, and push the

workpiece fully past the blade. When a small width is to be ripped and a push-stick cannot be safely put between the blade and rip fence, rip a larger piece to obtain the desired piece.

3. Turn on the saw and allow it to reach full speed. Place the trued edge of the board against the rip fence. Feed the workpiece slowly and evenly into the blade. Do not stand behind the board as shown in **Figure 37**.



Figure 37. Do not stand directly behind wood.

WARNING

Stand out of the line of potential kickback. Hold the workpiece firmly against the fence and table. Do not allow your fingers to get close to the blade! Do not reach over the blade to off-load the workpiece.



Dado Operations

In addition to its ability to rip and crosscut lumber, the table saw is also an invaluable tool for creating a variety of dados. These non-through cuts can be created with a regular saw blade or with specially-designed stacking or wobbling dado blades. See **Figure 38**.

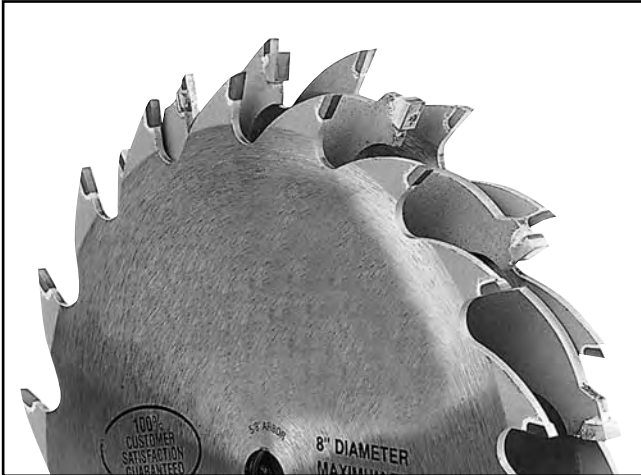

Figure 38. Optional dado blade system.

!WARNING

Never allow hands or arms to be above or behind the saw blade. Should kickback occur, the hands and arms can be pulled into the saw blade. Serious injury will result.

!WARNING

Never perform a through cut operation with a dado blade. A dado blade was designed to make non-through cuts only. Failure to follow these directions could result in serious injury will result.

!WARNING

Dado operations present very real hazards requiring proper procedures to avoid serious injury. The chance of kickback is always greater when dado blades are used so extra precautions must be used. Any movement of the stock away from the fence will cause kickback. Be certain that stock is flat and straight. Failure to follow these warnings could result in serious personal injury.

!CAUTION

Always use push sticks, featherboards, push paddles and other safety accessories whenever possible to increase safety and control during operations which require the blade guard and splitter to be removed from the saw. **ALWAYS** replace the blade guard after dadoing is complete.

Proper dado operations will differ depending on the blade system you choose. Consult the instructions included with your dado blades for directions regarding attachment and adjustment. To use a dado blade:

1. Ensure that the saw is switched off and disconnected from its power source.
2. Remove the table insert, splitter guard, regular saw blade, and 1" arbor. Install the long $\frac{5}{8}$ " dado arbor.
3. Attach and adjust the dado blade system as recommended in the dado blade's instructions.
4. Install the dado table insert.
5. Raise the blade system up to the desired depth of the dado. Make sure the dado blade will not cut through the work piece.
6. If dadoing along the length of your work-piece, adjust the distance between the fence and the inside edge of the blade to suit your needs. When cutting across the wood grain, use the miter gauge as a guide while dadoing. **Remember:** Never use the fence as a stop in conjunction with your miter gauge.
7. Reconnect the saw to the power source.
8. Using a scrap as a test piece, switch on the saw and take a pass over the dado blade.
9. If the cut is satisfactory, repeat with your finish stock.
10. Re-install the blade guard.

Dadoing operations can also be accomplished using a conventional saw blade. To create a single-blade dado:

1. Clearly mark the width of the dado cut on your workpiece. Include marks on the edge of your workpiece so you can clearly identify your intended cut while the material is laying flat on the saw table.
2. Set the blade height to the depth of cut you wish to create.
3. If the dado runs the length of the material, adjust the fence so the blade is aligned with the inside of your dado channel. See **Figure 39**.
4. Turn on your saw and make the first cut.

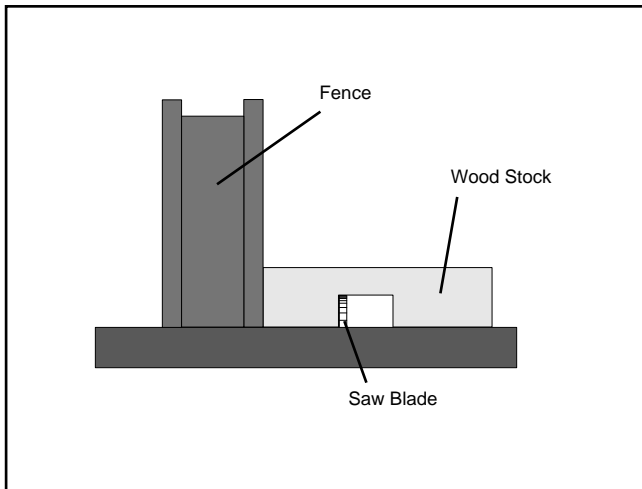

Figure 39. Single-blade dado cut.

5. Turn off the saw and readjust the fence so the blade is aligned with the other edge of the intended dado channel. Be sure to keep the cuts within your marks; otherwise, your dado will be too large.
6. Turn on the saw and make a second cut.
7. Move toward the center of the dado with your subsequent cuts until the dado is complete.
8. Re-install the blade guard.

Rabbet Operations

In addition to its ability to create a variety of dados, this table saw can be used to cut L-shaped rabbets. These cuts can be created with a regular saw blade or with specially-designed stacking or wobbling dado blades. See **Figure 38**.

Proper rabbet operation will differ depending on the blade system you choose. Consult the instructions included with your dado blades for directions regarding attachment and adjustment. To use a dado blade for rabbeting operations:

1. Rabbet cutting on the edge of a piece of stock requires the use of a sacrificial fence attachment. See **Figure 40**. The sacrificial fence can be made from a piece of wood that is as long as the metal fence and $\frac{3}{4}$ " thick. Once the sacrificial fence has been cut, attach it to the metal fence with screws or clamps, making sure they are all secure and tight.

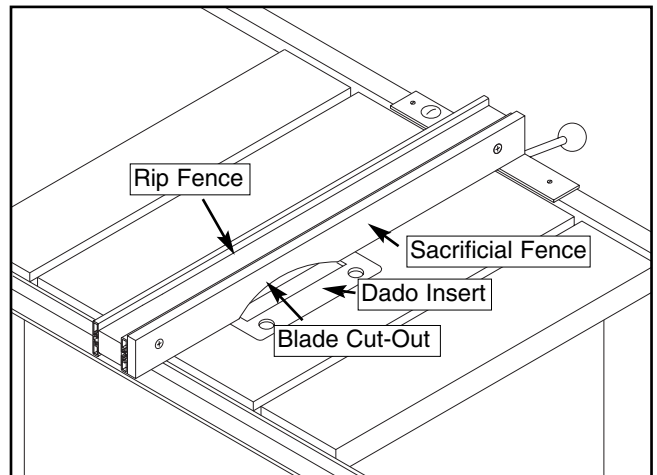

Figure 40. Sacrificial fence.



! CAUTION

Always use push sticks, featherboards, push paddles and other safety accessories whenever possible to increase safety and control during operations which require that the blade guard and splitter must be removed from the saw. ALWAYS replace the blade guard after dadoing is complete.

2. Ensure that the saw is switched off and disconnected from its power source.
3. Remove the table insert, splitter guard and the regular saw blade from the arbor.
4. Attach and adjust the dado blade system as recommended in the dado blade's instructions. Raise the blade system according to your needs. Make sure it will not cut through the workpiece.
5. If rabbeting along the length of your workpiece, adjust the distance between the fence and the outside edge of the blade to suit your needs. See **Figure 41**. When cutting across the wood grain, use the miter gauge as a guide while rabbeting. **Remember:** Never use the fence as a stop in conjunction with your miter gauge.
6. Using a scrap as a test piece, switch on the saw and take a pass over the dado blade.
7. If the cut is satisfactory, repeat with your finish stock.
8. Re-install the blade guard.

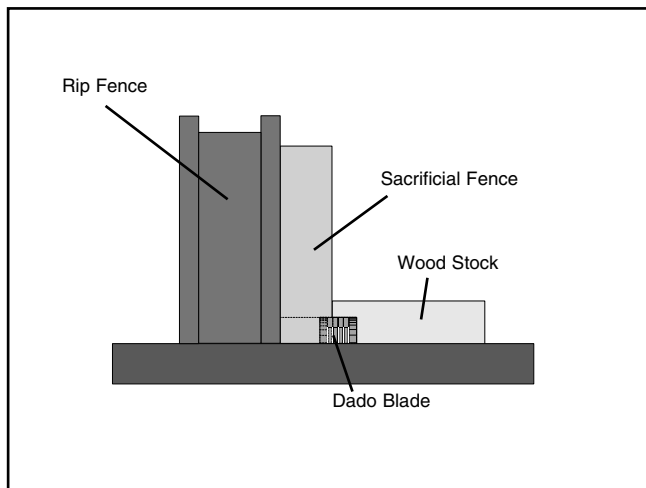

Figure 41. Rabbet cutting.

Rabbeting operations can also be accomplished using a conventional saw blade. To create a single-blade rabbet:

1. Clearly mark the width of the rabbet cut on your workpiece. Include marks on the edge of your workpiece so you can clearly identify your intended cut while the material is laying flat on the saw table.
2. Set the blade height to the depth of cut you wish to create.
3. If the rabbet runs the length of the material, adjust the fence so the blade is aligned with the inside of your rabbet channel.
4. Turn on your saw and make the first cut.
5. Turn off the saw and readjust the fence so that the next cut will remove another portion of the wood stock between the inside edge of the rabbet and the edge of the wood.
6. Turn on the saw and make a second cut.
7. Continue to readjust the blade and cut until the entire rabbet is made.
8. Re-install the blade guard.



! CAUTION

Instructions on using moulding heads have been intentionally left out. They are very dangerous when not used properly. Considerable skill and training beyond the scope of this manual are required to safely operate a moulding head. Serious personal injury could result if this warning is not followed.

SECTION 7: MAINTENANCE

General

Regular periodic maintenance on your Model G7209/10 will ensure its optimum performance. Make a habit of inspecting your machine each time you use it. Check for the following conditions and repair or replace when necessary:

1. Loose mounting bolts.
2. Worn switch.
3. Worn or damaged cords and plugs.
4. Damaged V-belt.
5. Any other condition that could hamper the safe operation of this machine.
6. Inspect blades for damage.
7. Guard alignment and operation.



Table

The nonpainted surfaces on the Model G7209/10 should be protected against rust and pitting. Wiping the machine clean after every use ensures that wood dust isn't allowed to trap moisture against bare metal surfaces.

Some woodworkers recommend using automotive paste wax on exposed steel and cast iron surfaces. The wax provides a layer of protection, as well as reducing friction between lumber and the table, making cuts faster and smoother. Avoid waxes that contain silicone or other synthetic ingredients. These materials can find their way into lumber that's being worked, and can make staining and finishing difficult. If you use paste wax, make sure that it's 100% Carnauba wax.



V-Belt

To ensure optimum power transmission from the motor to the blade, the V-belts must be in good condition and operate under proper tension. When replacing V-belts, it is important to replace all four at the same time - even if they do not all appear worn.

Belt tension should be checked at least every 3 months; more often if using the table saw intensively.

The V-belts are accessed through the cavity on the right side of the saw. They link the arbor and motor pulleys. To check V-belt tension:

1. Squeeze the center of each V-belt.
2. Note the amount of deflection. Deflection should be approximately $\frac{3}{4}$ ". See **Figure 42**.

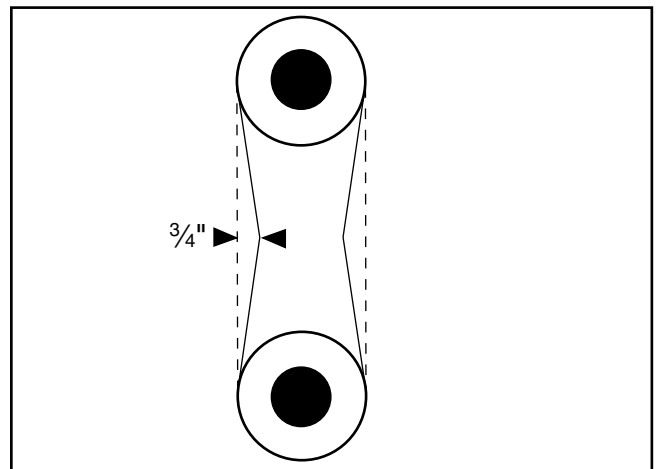
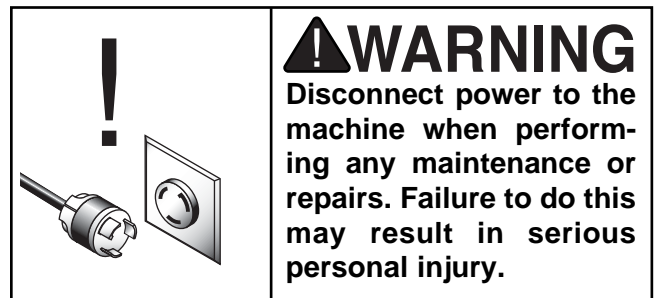

Figure 42.



WARNING

Disconnect power to the machine when performing any maintenance or repairs. Failure to do this may result in serious personal injury.

To adjust V-belt tension:

1. Loosen the motor mount bolt.
2. Shift the motor up or down to increase or decrease the V-belt tension. Tighten the motor mount bolt.
3. Check the V-belt tension again. Ensure that the motor pulley and arbor pulley are lined up.

To replace the V-belts:

1. Remove the blade.
2. Adjust the arbor so it is up all the way and in the 90° position.
3. Place a board under the motor and loosen the motor mount bolt. Slowly lower the arbor until the motor rests on the board, allowing the belts to be loose on the pulleys.
4. Pull off the old V-belts and replace them with new ones. Have the number from the belt ready when calling the service department for replacements.
5. Raise the arbor and remove the board to adjust the V-belt tension.
6. Tighten the motor mount bolt.

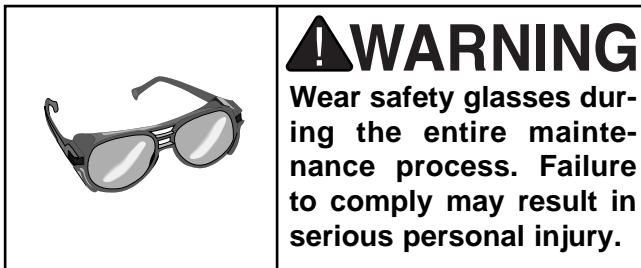
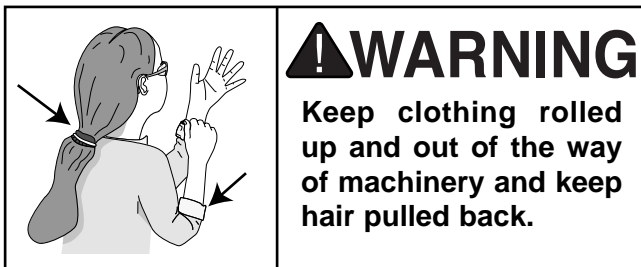

Lubrication

The shielded ball bearings in the motor and throughout the Model G7209/10 require no further lubrication during their lifetime. When they do wear out, replacements can be obtained through the Grizzly Parts Department.

Lubricate the areas indicated below every 12 months.

1. **Blade angling trunnions.** These should be lubricated with 6 or 7 drops of light machine oil.
2. **Blade height trunnion.** This should also be lubricated with 6 or 7 drops of light machine oil.
3. **The two (2) worm gears** should be lubricated with an automotive wheel bearing grease. The blade angle worm gear is not shown in **Figure 43**.

These points can be reached by removing the table. Check all adjustments when finished lubricating.

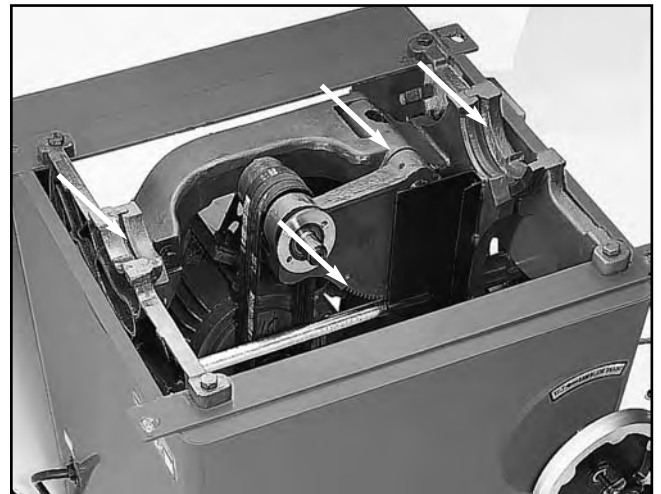

Figure 43. Lubricate these areas.



SECTION 8: CLOSURE

The following pages contain general machine data, troubleshooting guide, parts diagram, parts list and Warranty/Return information for your Model G7209/10 Table Saw.

If you need parts or help in assembling your machine, or if you need operational information, we encourage you to call the Customer Service Department. Our trained service technicians will be glad to help you.

If you have comments dealing specifically with this manual, please write to our Bellingham, Washington location using the address in the Introduction. The specifications, drawings, and photographs illustrated in this manual represent the Model G7209/10 Table Saw as supplied when the manual was prepared. However, due to Grizzly's policy of continuous improvement, changes may be made at any time with no obligation on the part of Grizzly. Whenever possible, though, we send manual updates to all owners of a particular tool or machine. Should you receive one, add the new information to this manual and keep it for reference.

We have included some important safety measures that are essential to this machine's operation. While most safety measures are generally universal, Grizzly reminds you that each workshop is different and safety rules should be considered as they apply to your specific situation.

We recommend you keep a copy of our current catalog for complete information regarding Grizzly's warranty and return policy. If you need additional technical information relating to this machine, or if you need general assistance or replacement parts, please contact the Customer Service Department listed in the introduction.

Additional information sources are necessary to realize the full potential of this machine. Trade journals, woodworking magazines, and your local library are good places to start.

WARNING

The Model G7209/10 was specifically designed for woodcutting operations. **DO NOT MODIFY AND/OR USE THIS MACHINE FOR ANY OTHER PURPOSE.** Modifications or improper use of this tool will void the warranty. If you are confused about any aspect of this machine, **DO NOT** use it until all your questions have been answered. **Serious personal injury may occur.**

WARNING

Like all power tools, there is danger associated with the Model G7209/10. Accidents are frequently caused by lack of familiarity or failure to pay attention. Use this tool with respect and caution to lessen the possibility of operator injury. If normal safety precautions are overlooked or ignored, serious personal injury may occur.

WARNING

Operating this equipment has the potential for flying debris to cause eye injury. Always wear safety glasses or goggles when operating equipment. Everyday glasses or reading glasses only have impact resistant lenses, they are not safety glasses. Be certain the safety glasses you wear meet the appropriate standards of the American National Standards Institute (ANSI).

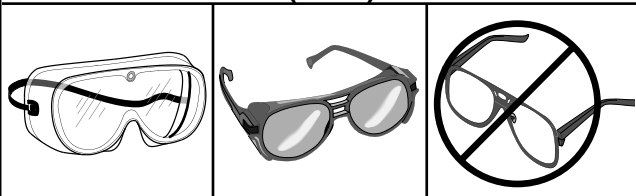



MACHINE DATA SHEET

Customer Service #: (570) 546-9663 • To Order Call: (800) 523-4777 • Fax #: (800) 438-5901

GRIZZLY MODEL G7209 14" TABLE SAW

Design Type Tilting Arbor

Overall Dimensions:

With Wings and Fence Rails82" W x 47" D x 42" H
 Table Height35½"
 Table Size28" x 38"
 Table Size w/ Extension Wings48½" x 38"
 Miter Gauge Groove Type / SizeT-slot / ½" x ⅝"
 Weight (Shipping)1000 lbs.
 Box # 1 Size43½" L x 36½" W x 42" H
 Box # 2 Size49" L x 17" W x 5" H
 Footprint31" x 27½"

Construction:

TablePrecision-Ground Cast Iron
 CabinetPreformed Steel
 FenceSingle Lever, Front Locking, Extruded Aluminum Sides
 Rails77⅞" L x 2" Square Tubing, Front
 Miter GaugeCast Iron
 TrunnionsCast Iron
 Spindle BearingsShielded and Lubricated Ball Bearings

Capacities:

Maximum Blade Diameter14"
 Maximum Depth of Cut at 90°5"
 Blade Tilt0 - 45° Right
 Maximum Depth of Cut at 45°3⅞"
 Maximum Rip to Right of Blade50¾"
 Maximum Rip to Left of Blade9¾"
 Distance Front of Table to Center of Blade22½"
 Distance Front of Table at Maximum Cut15½"

Motor:

TypeTEFC Capacitor Start Induction
 Horsepower5 H.P.
 Phase / CycleSingle Phase / 60 HZ
 Voltage220V
 Amps30 A
 Motor R.P.M.3450 R.P.M.
 Power TransferQuadruple Belt Drive
 BearingsShielded and Lubricated Ball Bearings
 SwitchMagnetic with Thermal Overload Protection

Arbor:

Arbor Diameter1"
 Arbor Speed3850 R.P.M.

Features:

.....4" Dust Port
Machined Collars
Inboard & Outboard Bearings

Specifications, while deemed accurate, are not guaranteed.



MACHINE DATA SHEET

Customer Service #: (570) 546-9663 • To Order Call: (800) 523-4777 • Fax #: (800) 438-5901

GRIZZLY MODEL G7210 14" TABLE SAW

Design Type Tilting Arbor

Overall Dimensions:

With Wings and Fence Rails82" W x 47" D x 42" H
 Table Height35½"
 Table Size28" x 38"
 Table Size w/ Extension Wings48½" x 38"
 Miter Gauge Groove Type / SizeT-slot / ½" x ⅝"
 Weight (Shipping)1000 lbs.
 Box # 1 Size43½" L x 36½" W x 42" H
 Box # 2 Size49" L x 17" W x 5" H
 Footprint31" x 27½"

Construction:

TablePrecision-Ground Cast Iron
 CabinetPreformed Steel
 FenceSingle Lever, Front Locking, Extruded Aluminum Sides
 Rails77⅜" L x 2" Square Tubing, Front
 Miter GaugeCast Iron
 TrunnionsCast Iron
 Spindle BearingsShielded and Lubricated Ball Bearings

Capacities:

Maximum Blade Diameter14"
 Maximum Depth of Cut at 90°5"
 Blade Tilt0 - 45° Right
 Maximum Depth of Cut at 45°3⅞"
 Maximum Rip to Right of Blade50¾"
 Maximum Rip to Left of Blade9⅞"
 Distance Front of Table to Center of Blade22½"
 Distance Front of Table at Maximum Cut15½"

Motor:

Horsepower7½ H.P.
 Phase / CycleThree Phase / 60 HZ
 Voltage220V/440V
 Amps22A/11A
 Motor R.P.M.3450 R.P.M.
 Power TransferQuadruple Belt Drive
 BearingsShielded and Lubricated Ball Bearings
 SwitchMagnetic with Thermal Overload Protection

Arbor:

Arbor Diameter1"
 Arbor Speed3850 R.P.M.

Features:

.....4" Dust Port
Machined Collars
Inboard & Outboard Bearings

Specifications, while deemed accurate, are not guaranteed.

5 HP Magnetic Switch -NHD Type

⚠ DANGER
Disconnect power from machine before performing any electrical service. Failure to do this will result in a shock hazard leading to injury or death.

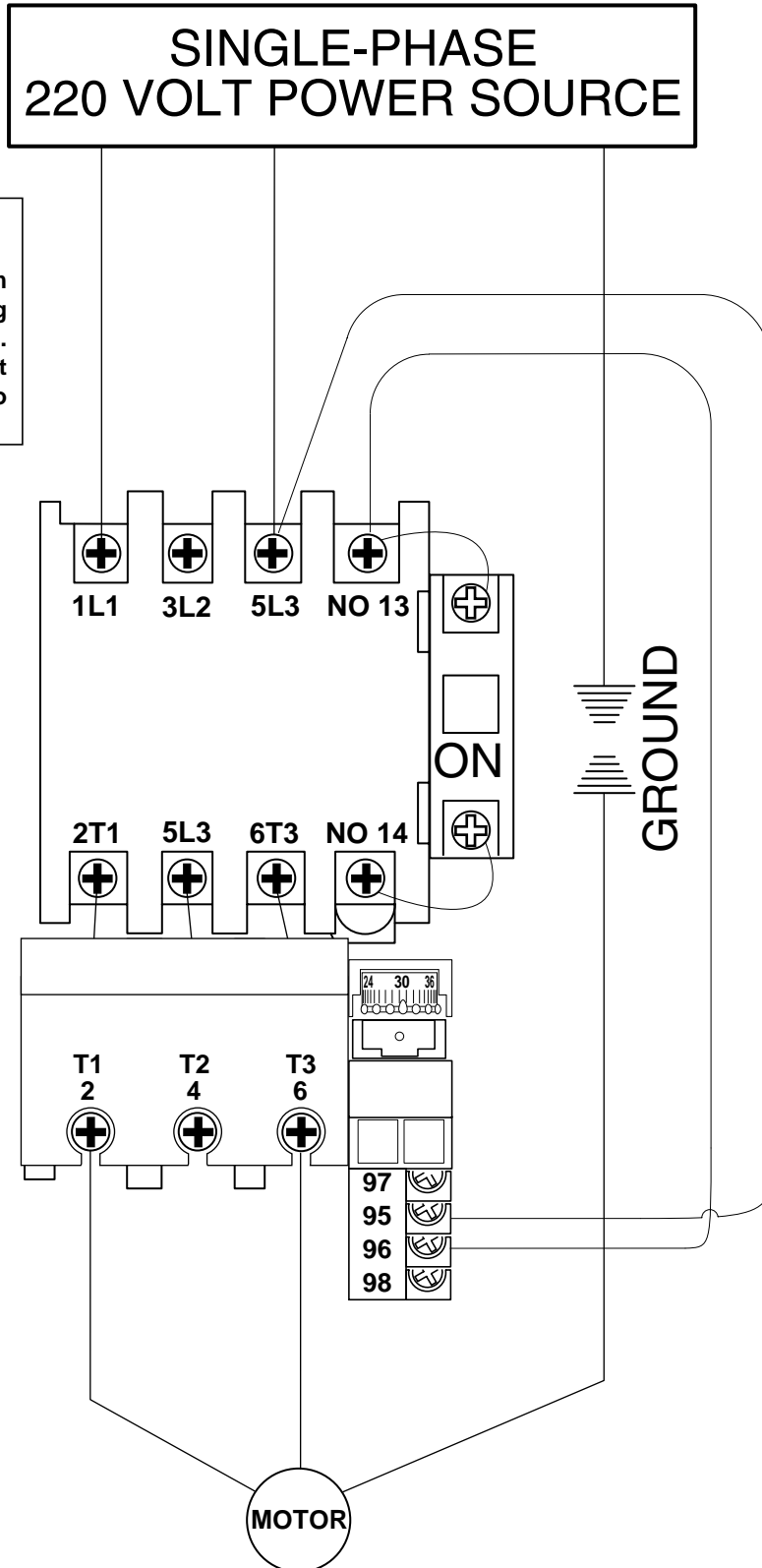

7-1/2 HP Magnetic Switch -NHD Type

THREE-PHASE
220 VOLT POWER SOURCE

⚠ DANGER

Disconnect power from machine before performing any electrical service. Failure to do this will result in a shock hazard leading to injury or death.

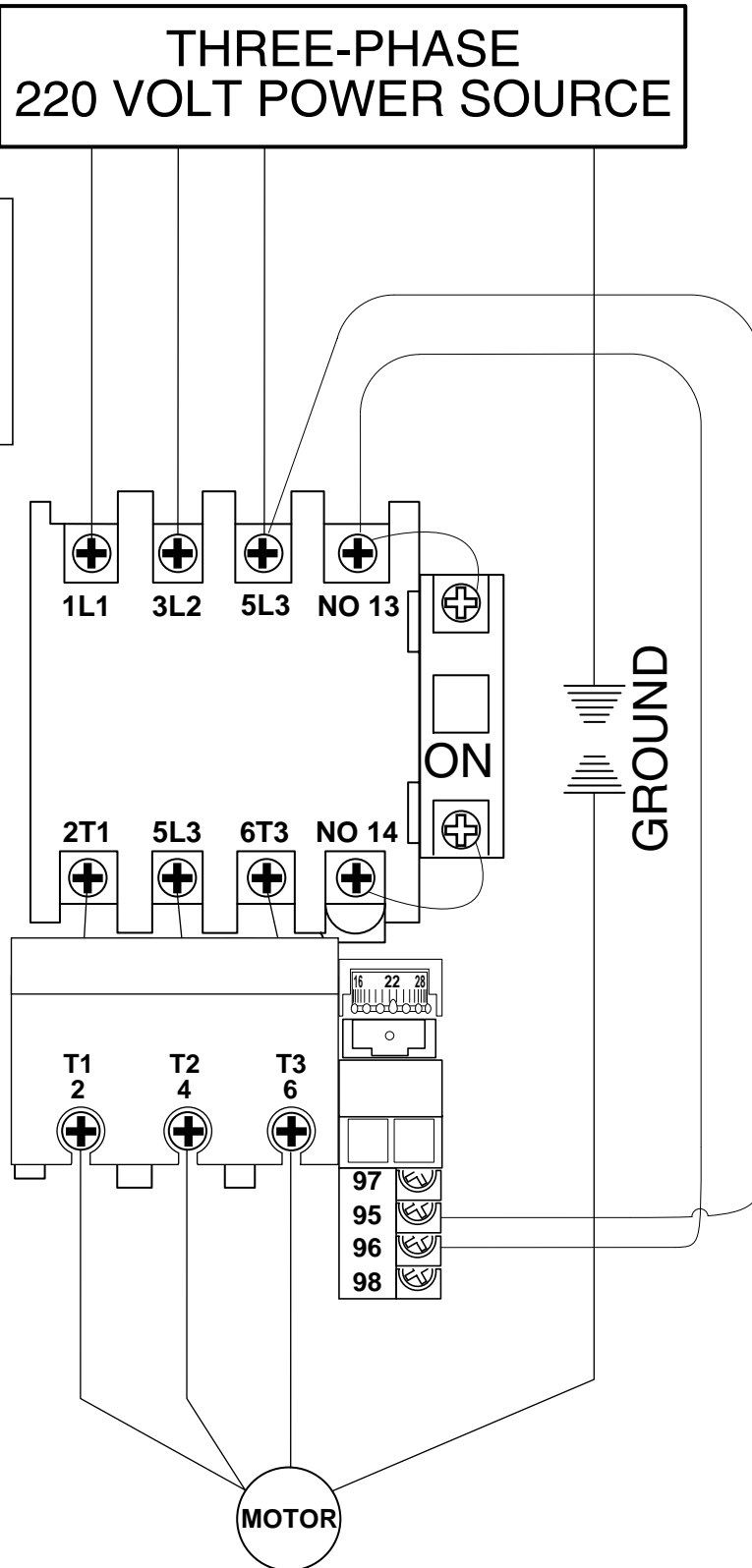

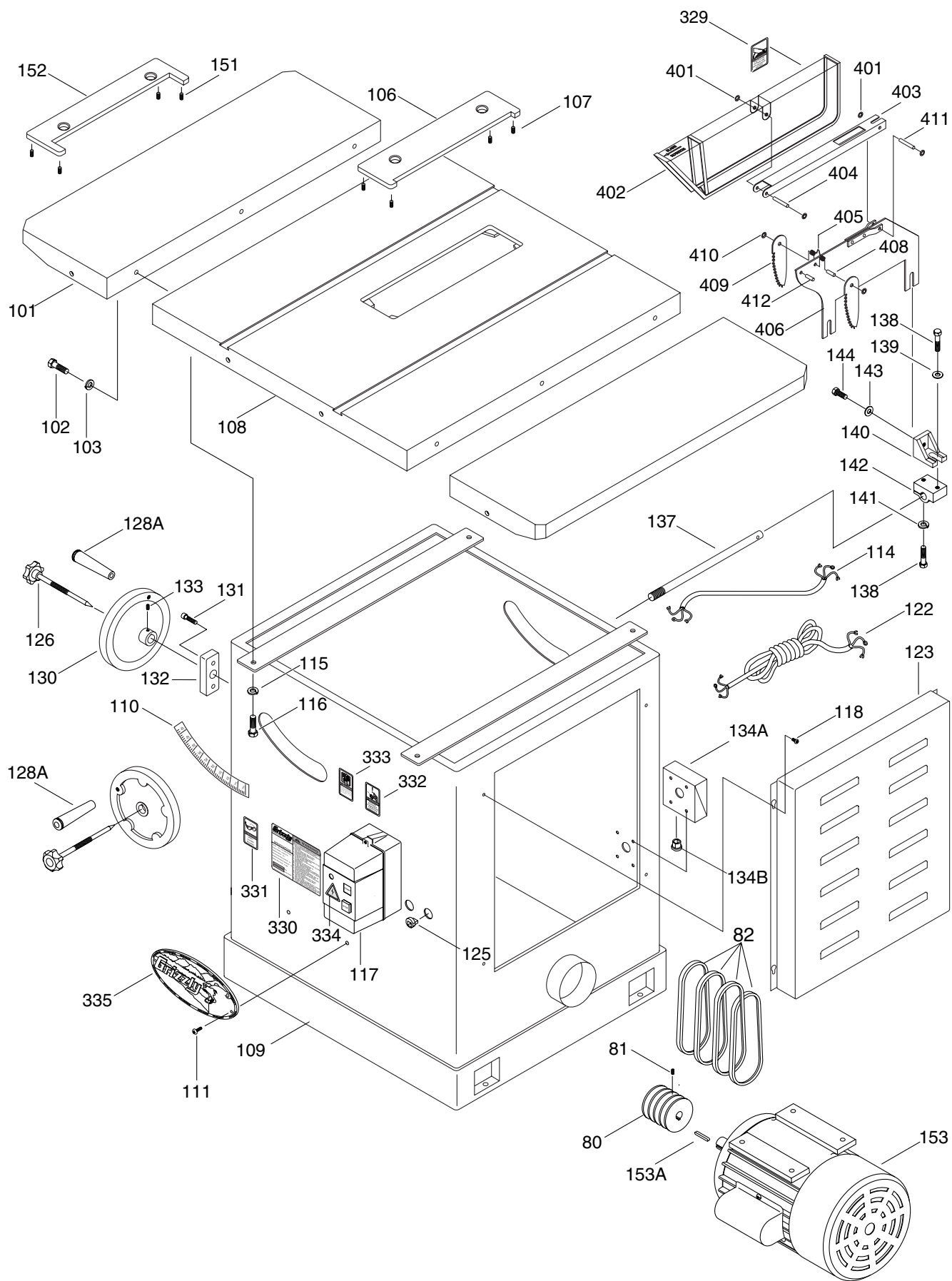

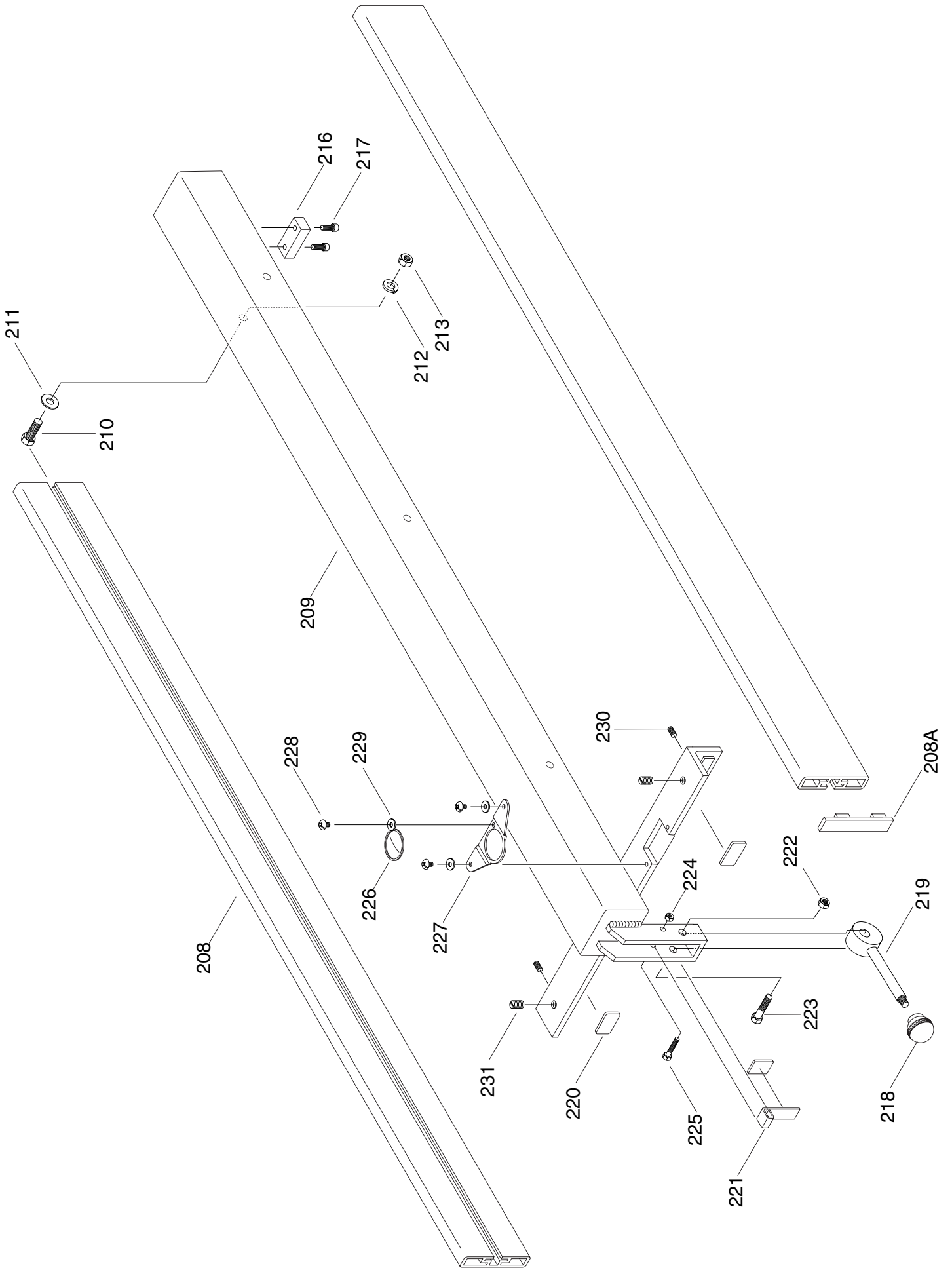

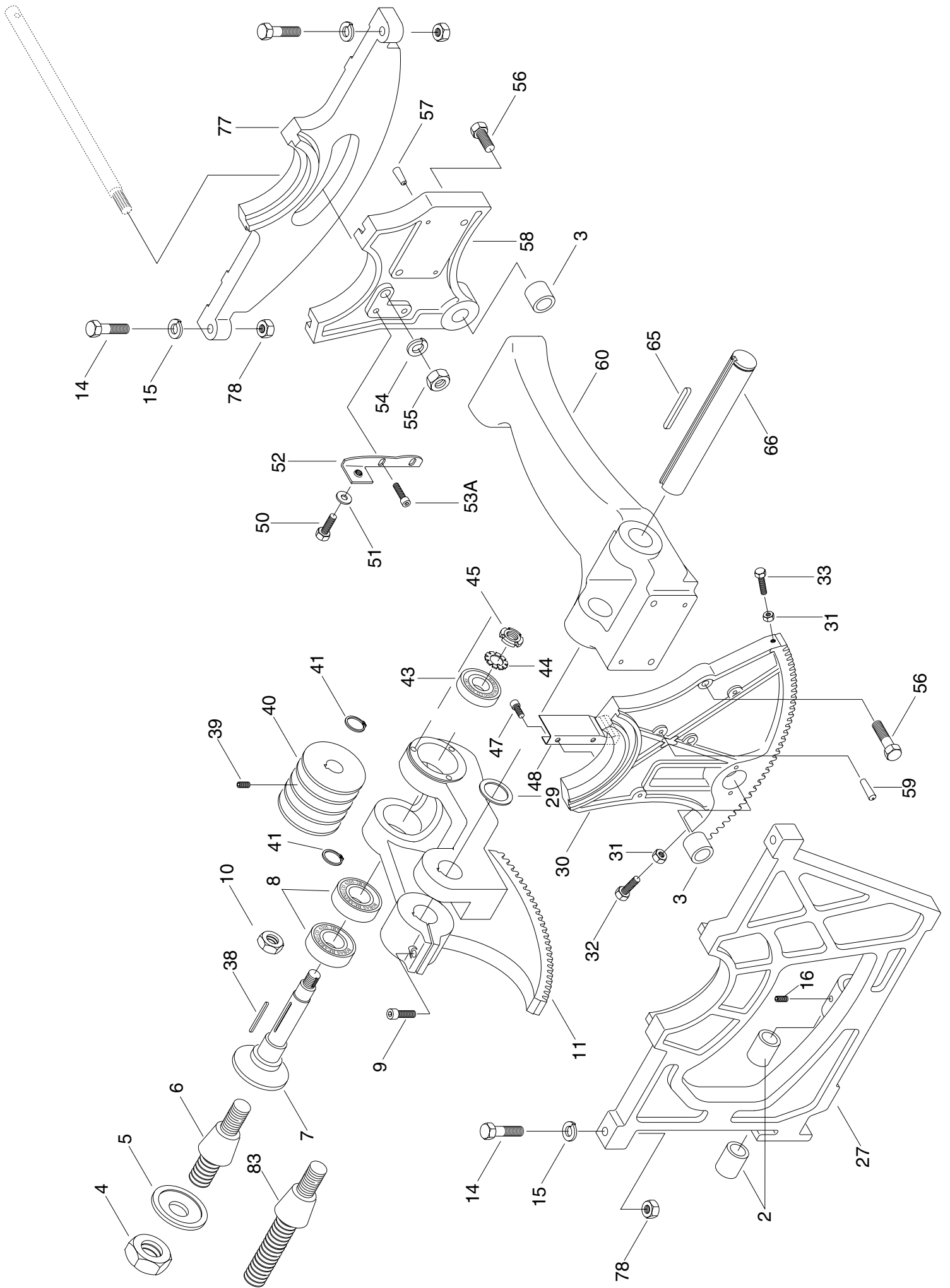

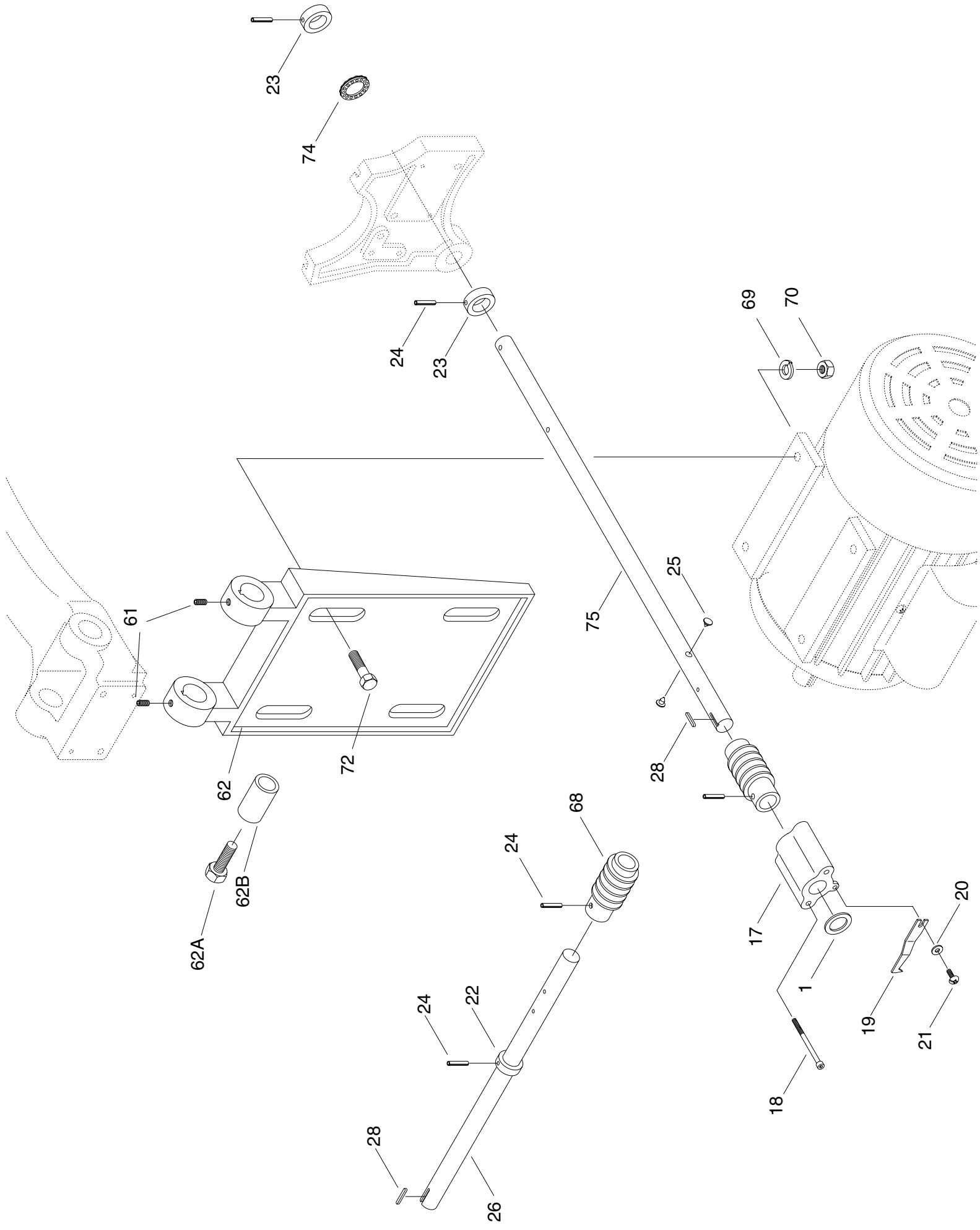

| REF | PART # | DESCRIPTION |
|------|-----------|--------------------------|
| 002 | P7209002 | BUSHING |
| 003 | P7209003 | BUSHING |
| 004 | P7209004 | ARBOR NUT 1" |
| 005 | P7209005 | BLADE FLANGE 1" |
| 006 | P7209006 | ARBOR ADAPTER 1" |
| 007 | P7209007 | ARBOR |
| 008 | P6006 | BALL BEARING 6006 |
| 009 | PSB31M | CAP SCREW M8-1.25 X 25 |
| 010 | P7209010 | BEARING NUT |
| 011 | P7209011 | ARBOR BRACKET |
| 014 | P7209014 | HEX BOLT M12-1.75 X 35 |
| 015 | PLW05M | LOCK WASHER 12MM |
| 016 | PSS02M | SET SCREW M6-1 X 6 |
| 017 | P7209017 | INDICATOR BRACKET |
| 018 | P7209018 | CAP SCREW M6-1.0 X 75 |
| 019 | P7209019 | INDICATOR |
| 020 | PW02M | FLAT WASHER 5MM |
| 021 | P7209021 | ROUND HD SCREW M5-.8 X 8 |
| 022 | P7209022 | COLLAR |
| 023 | P7209023 | COLLAR |
| 024 | P7209024 | ROLL PIN |
| 025 | P7209025 | LIMIT STUD |
| 026 | P7209026 | TILT ADJUSTMENT SHAFT |
| 027 | P7209027 | FRONT TRUNNION BRACKET |
| 028 | PK12M | KEY 5 X 5 X 30 |
| 029 | P7209029 | WASHER |
| 030 | P7209030 | FRONT TRUNNION |
| 031 | PN03M | HEX NUT M8-1.25 |
| 032 | PB20M | HEX BOLT M8-1.25 X 35 |
| 033 | PB20M | HEX BOLT M8-1.25 X 35 |
| 034 | P7209034 | PIVOT SHAFT |
| 035 | P7209035 | HEX BOLT M12-1.75 X 15 |
| 036 | PW06M | FLAT WASHER 12MM |
| 037 | P7209037 | COTTER PIN |
| 038 | PK33M | KEY 5 X 5 X 45 |
| 039 | PSS02M | SET SCREW M6-1.0 X 6 |
| 040 | P7209040 | DRIVE PULLEY |
| 041 | P7209041 | SNAP RING, R30 |
| 043 | P6204 | BALL BEARING 6204 |
| 044 | P7209044 | WASHER |
| 045 | P7209045 | LOCKING NUT 20MM |
| 047 | PSB58M | CAP SCREW M8-1.25 X 12 |
| 048 | P7209048 | DUST DEFLECTOR |
| 050 | PB06M | HEX BOLT M8-1.25 X 12 |
| 051 | PW01M | FLAT WASHER 8MM |
| 052 | P7209052 | FRONT SUPPORT BRACKET |
| 053A | PSB31M | CAP SCREW M8-1.25 X 25 |
| 054 | PLW05M | LOCK WASHER 12MM |
| 055 | PN09M | HEX NUT M12-1.75 |
| 056 | P7209056 | CAP SCREW M10-1.5 X 25 |
| 057 | P7209057 | TAPER PIN #4 X 20 |
| 058 | P7209058 | REAR TRUNNION |
| 059 | P7209059 | TAPER PIN #4 X 25 |
| 060 | P7209060 | ARM |
| 061 | PSS20M | SET SCREW M8-1.25 X 8 |
| 062 | P7209062 | MOTOR MOUNT SUPPORT |
| 062A | PB38M | HEX BOLT M12-1.75 X 60 |
| 062B | P7209062B | SPACER |
| 066 | P7209066 | SHAFT |

| REF | PART # | DESCRIPTION |
|------|-----------|--------------------------|
| 068 | P7209068 | WORM GEAR |
| 069 | PLW05M | LOCK WASHER 12MM |
| 070 | PN09M | HEX NUT M12-1.75 |
| 072 | PB31M | HEX BOLT M10-1.5 X 45 |
| 074 | P51104 | THRUST BEARING |
| 075 | P7209075 | HEIGHT ADJUSTMENT SHAFT |
| 077 | P7209077 | REAR TRUNNION BRACKET |
| 078 | PN09M | HEX NUT M12-1.75 |
| 079 | P7209079 | BUSHING |
| 080 | P7209080 | MOTOR PULLEY |
| 081 | PSS02M | SET SCREW M6-1.0 X 6 |
| 082 | PVA28 | V-BELT A-28 4L280 |
| 083 | P7209083 | ARBOR EXTENSION DADO 1" |
| 084 | PAW08M | ALLEN WRENCH 8MM |
| 085 | P7209085 | SPANNER WRENCH |
| 087 | PAW05M | ALLEN WRENCH 5MM |
| 088 | PAW03M | ALLEN WRENCH 3MM |
| 089 | PWR1214 | 12 X 14 WRENCH |
| 090 | PWR1719 | 17 X 19 WRENCH |
| 101 | P7209101 | EXTENSION TABLE |
| 102 | PB75M | HEX BOLT M12-1.75 X 35 |
| 103 | PLW05M | LOCK WASHER 12MM |
| 104 | PSB02M | CAP SCREW M6-1 X 20 |
| 105 | P7209105 | T BLOCKS |
| 106 | P7209106 | BLADE INSERT |
| 107 | PSS03M | SET SCREW M6-1 X 8 |
| 108 | P7209108 | TABLE |
| 109 | P7209109 | BASE |
| 110 | P7209110 | INDICATOR PLATE |
| 111 | P7209111 | RND HD SCR M3-.5 X 15 |
| 114 | P7209114 | LINE CORD - SHORT |
| 115 | PLW05M | LOCK WASHER 12MM |
| 116 | P7209116 | HEX BOLT M12-1.75 X 35 |
| 117 | P7209117 | MAGNETIC SWITCH |
| 118 | P7209118 | RND HD SCR M5-.80 X 8 |
| 122 | P7209122 | LINE CORD - LONG |
| 123 | P7209123 | DOOR |
| 125 | P7209125 | STRAIN RELIEF |
| 126 | P7209126 | LOCKING KNOB |
| 128A | P7209128A | CRANK HANDLE |
| 130 | P7209130 | HANDWHEEL |
| 131 | PSB61M | CAP SCREW M10-1.5 X 20 |
| 132 | P7209132 | SHIELD PLATE |
| 133 | PSS02M | SET SCREW M6-1 X 6 |
| 134 | P7209125 | STRAIN RELIEF |
| 134A | P7209134A | WIRE COVER |
| 134B | P7209134B | STRAIN RELIEF |
| 136 | P7209136 | HANDWHEEL |
| 137 | P7209137 | GUARD SUPPORT ROD |
| 138 | PB07M | HEX BOLT M8-1.25 X 25 |
| 139 | PW01M | FLAT WASHER 8MM |
| 140 | P7209140 | GUARD SUPPORT (UPPER) |
| 141 | PLW04M | LOCK WASHER 8MM |
| 142 | P7209142 | GUARD SUPPORT (LOWER) |
| 143 | PW01M | FLAT WASHER 8MM |
| 144 | PB06M | HEX BOLT M8-1.25 X 12 |
| 145 | P7209145 | FENCE GUIDE RAIL (FRONT) |
| 146 | P7209146 | FENCE GUIDE RAIL (REAR) |
| 147 | P7209147 | T BOLT |

| REF | PART # | DESCRIPTION |
|------|-----------|--------------------------|
| 148 | P7209148 | SPACER |
| 149 | PLW06M | LOCK WASHER 10MM |
| 150 | PN02M | HEX NUT M10-1.5 |
| 151 | PSS03M | SET SCREW M6-1.0 X 8 |
| 152 | P7209152 | DADO INSERT |
| 153 | P7209153 | MOTOR |
| 153A | | KEY 8 X 8 X 30 |
| 201 | P7209201 | FRONT RAIL |
| 202 | P7209202 | BACK RAIL |
| 203 | P7209203 | SQUARE TUBE |
| 204 | P7209204 | TAPE SCALE |
| 205 | PB03M | HEX BOLT M8-1.25 X 16 |
| 206 | PLW04M | LOCK WASHER 8MM |
| 207 | PFH08M | FLAT HD SCR M8-1.25 X 12 |
| 208 | P7209208 | FENCE SIDE |
| 208A | P7209208A | FENCE END CAP |
| 209 | P7209209 | MAIN FENCE BODY |
| 210 | | HEX BOLT M10-1.5 X 20 |
| 211 | PW04M | FLAT WASHER 10MM |
| 212 | PLW06M | LOCK WASHER 10MM |
| 213 | PN02M | HEX NUT M10-1.5 |
| 214 | PB26M | HEX BOLT M8-1.25 X 30 |
| 215 | P7209215 | RAIL SPACER |
| 216 | P7209216 | NYLON BLOCK |
| 217 | PS20M | PHLP HD SCR M5-.8 X 15 |
| 218 | P1021134 | LOCK KNOB |
| 219 | P7209219 | LOCK HANDLE |
| 220 | P7209220 | TEFLON PAD |
| 221 | P7209221 | FENCE LOCK (CLAMP SHOE) |
| 222 | PLN01 | LOCK NUT 3/8"-16 |
| 223 | PB25 | HEX BOLT 3/8"-16 X 1 3/4 |
| 224 | PLN03M | LOCK NUT M6-1.0 |
| 225 | P7209225 | CAP SCREW M6-1.0 X 40 |
| 226 | P7209226 | HAIRLINE INDICATOR |
| 227 | P7209227 | INDICATOR BRACKET |
| 228 | PS05M | PHLP HD SCR M5-.8 X 8 |
| 229 | PW02M | FLAT WASHER 5MM |
| 230 | PSS16M | SET SCREW M8-1.25 X 10 |
| 231 | P7209231 | NYLON ADJUSTING SCREW |
| 233 | P7209233 | BAR END CAP |
| 254 | P7209254 | TOOL BOX W/O ARBOR EXTS |
| 255 | P7209255 | HARDWARE BAG |
| 256 | P7209256 | COMPLETE GUARD ASSY |

| REF | PART # | DESCRIPTION |
|-----|----------|--------------------------|
| 301 | P7209301 | HANDLE |
| 302 | PW04M | FLAT WASHER 10MM |
| 303 | P7209303 | BAR |
| 304 | P7209304 | GAUGE |
| 305 | P7209305 | INDICATOR |
| 308 | PSS02M | SET SCREW M6-1 X 6 |
| 310 | P7209310 | SPECIAL WASHER |
| 311 | PFH04M | FLAT HD SCR M6-1 X 8 |
| 329 | P7209329 | GUARD WARNING LABEL |
| 330 | P7209330 | ID/WARNING LABEL |
| 331 | P7209331 | GLASSES WARNING LABEL |
| 332 | P7209332 | UNPLUG WARNING LABEL |
| 333 | P7209333 | READ MANUAL LABEL |
| 334 | P7209334 | ELECTRICAL WARNING LABEL |
| 335 | P7209335 | CAST LOGO |
| 401 | P7209401 | RETAINER |
| 402 | P7209402 | GUARD |
| 403 | P7209403 | SUPPORT ARM |
| 404 | P7209404 | PIN |
| 405 | P7209405 | SPRING |
| 406 | P7209406 | BLADE SPLITTER |
| 407 | P7209407 | SPACER |
| 408 | P7209408 | PIN |
| 409 | P7209409 | PAWL |
| 410 | P7209410 | RETAINER |
| 411 | P7209411 | PIN |
| 412 | PRP42M | ROLL PIN 3 X 20 |

TROUBLESHOOTING GUIDE

| SYMPTOM | POSSIBLE CAUSE | CORRECTIVE ACTION |
|---|---|---|
| Motor will not start. | <ol style="list-style-type: none"> 1. Low voltage. 2. Open circuit in motor or loose connections. | <ol style="list-style-type: none"> 1. Check power line for proper voltage. 2. Inspect all lead connections on motor for loose or open connections. |
| Motor will not start; fuses or circuit breakers blow. | <ol style="list-style-type: none"> 1. Short circuit in line cord or plug. 2. Short circuit in motor or loose connections. 3. Incorrect fuses or circuit breakers in power line. | <ol style="list-style-type: none"> 1. Inspect cord or plug for damaged insulation and shorted wires. 2. Inspect all connections on motor for loose or shorted terminals or worn insulation. 3. Install correct fuses or circuit breakers. |
| Motor overheats. | <ol style="list-style-type: none"> 1. Motor overloaded. 2. Air circulation through the motor restricted. | <ol style="list-style-type: none"> 1. Reduce load on motor. 2. Clean out motor to provide normal air circulation. |
| Motor stalls (resulting in blown fuses or tripped circuit). | <ol style="list-style-type: none"> 1. Short circuit in motor or loose connections. 2. Low voltage. 3. Incorrect fuses or circuit breakers in power line. 4. Motor overloaded. | <ol style="list-style-type: none"> 1. Inspect connections on motor for loose or shorted terminals or worn insulation. 2. Correct the low voltage conditions. 3. Install correct fuses or circuit breakers. 4. Reduce load on motor. |
| Machine slows when operating. | Applying too much pressure to workpiece. | Feed workpiece slower. |
| Loud, repetitious noise coming from machine. | <ol style="list-style-type: none"> 1. Pulley setscrews or keys are missing or loose. 2. Motor fan is hitting the cover. 3. V-belts are defective | <ol style="list-style-type: none"> 1. Inspect keys and setscrews. Replace or tighten if necessary. 2. Tighten fan or shim cover. 3. Replace V-belts. See Maintenance. |
| Blade is not square w/miter slot or fence is not square to blade. | <ol style="list-style-type: none"> 1. Blade is warped. 2. Table top is not parallel to blade. 3. Fence is not parallel to blade. | <ol style="list-style-type: none"> 1. Replace blade. 2. Make table parallel to blade. See Adjustments. 3. Make fence parallel to blade. See Adjustments. |
| Fence hits table top when sliding on to the table. | <ol style="list-style-type: none"> 1. Front rail is bolted too low on the table. 2. Rear rail is bolted too low on the table. | <ol style="list-style-type: none"> 1. Raise front rail. 2. Raise rear rail. |
| Blade does not reach 90°. | <ol style="list-style-type: none"> 1. 90° stop bolt is out of adjustment. 2. Pointer bracket is hitting before the blade reaches 90°. | <ol style="list-style-type: none"> 1. Adjust 90° stop bolt. See Adjustments. 2. File down the right side of the pointer bracket until the blade can reach 90°. |
| Blade hits insert at 45°. | <ol style="list-style-type: none"> 1. Hole in insert is inadequate. 2. Table out of alignment. 3. Blade position is incorrect. | <ol style="list-style-type: none"> 1. File or mill the hole in the insert. 2. Align table. See Adjustments. 3. Adjust blade position. See Adjustments. |
| Blade won't go beneath table surface. | Table top too low. | Raise table top w/washers. |
| Hand wheels won't turn. | <ol style="list-style-type: none"> 1. Hand wheel key is inserted too far. 2. Bullets are wedged. 3. Roll pin or setscrew in worm gear is contacting geared trunnion. | <ol style="list-style-type: none"> 1. Remove hand wheel and adjust key. 2. Remove hand wheel and adjust bullets. 3. Inspect roll pins and setscrews in the worm gear. Tighten if necessary. |

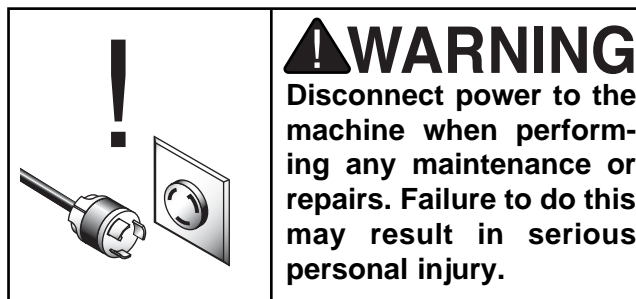

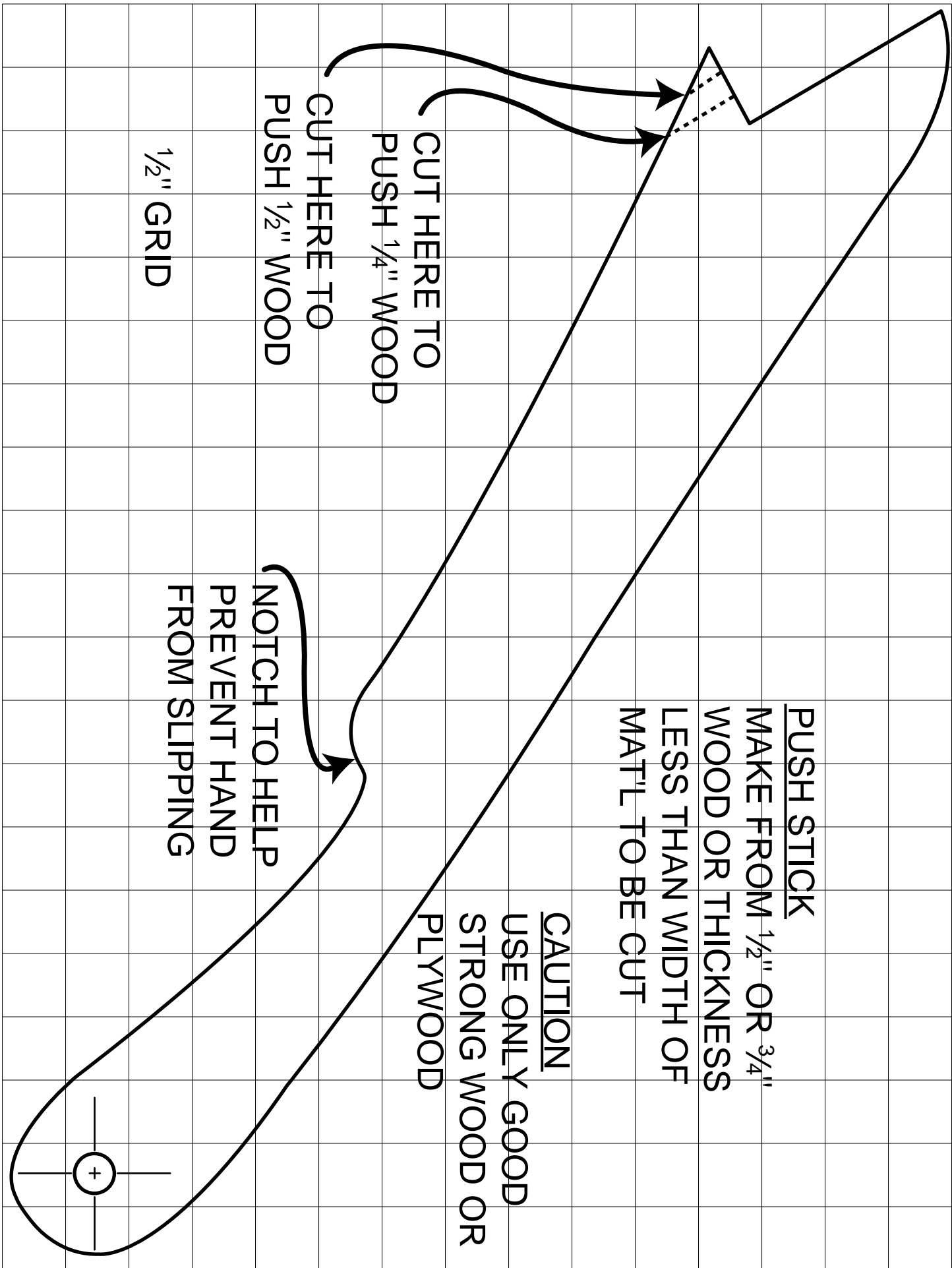

WARRANTY AND RETURNS

Grizzly Industrial, Inc. warrants every product it sells for a period of **1 year** to the original purchaser from the date of purchase. This warranty does not apply to defects due directly or indirectly to misuse, abuse, negligence, accidents, repairs or alterations or lack of maintenance. This is Grizzly's sole written warranty and any and all warranties that may be implied by law, including any merchantability or fitness, for any particular purpose, are hereby limited to the duration of this written warranty. We do not warrant or represent that the merchandise complies with the provisions of any law or acts unless the manufacturer so warrants. In no event shall Grizzly's liability under this warranty exceed the purchase price paid for the product and any legal actions brought against Grizzly shall be tried in the State of Washington, County of Whatcom.

We shall in no event be liable for death, injuries to persons or property or for incidental, contingent, special, or consequential damages arising from the use of our products.

To take advantage of this warranty, contact us by mail or phone and give us all the details. We will then issue you a "Return Number," which must be clearly posted on the outside as well as the inside of the carton. We will not accept any item back without this number. Proof of purchase must accompany the merchandise.

The manufacturers reserve the right to change specifications at any time because they constantly strive to achieve better quality equipment. We make every effort to ensure that our products meet high quality and durability standards and we hope you never need to use this warranty.

Please feel free to write or call us if you have any questions about the machine or the manual.

Thank you again for your business and continued support. We hope to serve you again soon.

WARRANTY CARD

Name _____
Street _____
City _____ State _____ Zip _____
Phone Number _____ E-Mail _____ FAX _____
MODEL # _____ Order # _____

The following information is given on a voluntary basis. It will be used for marketing purposes to help us develop better products and services. Of course, all information is strictly confidential.

- How did you learn about us?
 Advertisement Friend
 Catalog Card Deck
 World Wide Web
 Other _____
- Which of the following magazines do you subscribe to.
 American Woodworker Practical Homeowner
 Cabinetmaker Shop Notes
 Family Handyman Today's Homeowner
 Fine Homebuilding WOOD
 Fine Woodworking Wooden Boat
 Home Handyman Woodshop News
 Journal of Light Construction Woodsmith
 Old House Journal Woodwork
 Popular Mechanics Woodworker
 Popular Science Woodworker's Journal
 Popular Woodworking Workbench
 Other _____
- Which of the following woodworking/remodeling shows do you watch?
 Backyard America The New Yankee Workshop
 Home Time This Old House
 The American Woodworker Woodwright's Shop
 Other _____
- What is your annual household income?
 \$20,000-\$29,999 \$60,000-\$69,999
 \$30,000-\$39,999 \$70,000-\$79,999
 \$40,000-\$49,999 \$80,000-\$89,999
 \$50,000-\$59,999 \$90,000 +
- What is your age group?
 20-29 50-59
 30-39 60-69
 40-49 70 +
- How long have you been a woodworker?
 0 - 2 Years 8 - 20 Years
 2 - 8 Years 20+ Years
- How would you rank your woodworking skills?
 Simple Advanced
 Intermediate Master Craftsman
- What stationary woodworking tools do you own? Check all that apply.
 Air Compressor Panel Saw
 Band Saw Planer
 Drill Press Power Feeder
 Drum Sander Radial Arm Saw
 Dust Collector Shaper
 Horizontal Boring Machine Spindle Sander
 Jointer Table Saw
 Lathe Vacuum Veneer Press
 Mortiser Wide Belt Sander
 Other _____
- How many of your woodworking machines are Grizzly? _____
- Which benchtop tools do you own? Check all that apply.
 1" x 42" Belt Sander 6" - 8" Grinder
 5" - 8" Drill Press Mini Lathe
 8" Table Saw 10" - 12" Thickness Planer
 8" - 10" Bandsaw Scroll Saw
 Disc/Belt Sander Spindle/Belt Sander
 Mini Jointer
 Other _____
- How many of the machines checked above are Grizzly? _____
- Which portable/hand held power tools do you own? Check all that apply.
 Belt Sander Orbital Sander
 Biscuit Joiner Palm Sander
 Circular Saw Portable Planer
 Detail Sander Saber Saw
 Drill/Driver Reciprocating Saw
 Miter Saw Router
 Other _____
- What machines/supplies would you like Grizzly Industrial to carry?

- What new accessories would you like Grizzly Industrial to carry?

- What other companies do you purchase your tools and supplies from?

- Do you think your purchase represents good value?
 Yes No
- Would you recommend Grizzly Industrial to a friend?
 Yes No
- Would you allow us to use your name as a reference for Grizzly customers in your area? **Note: We never use names more than three times.**
 Yes No
- Comments: _____

CUT ALONG DOTTED LINE

FOLD ALONG DOTTED LINE



Place
Stamp
Here



GRIZZLY INDUSTRIAL, INC.
P.O. BOX 2069
BELLINGHAM, WA 98227-2069



FOLD ALONG DOTTED LINE

Send a Grizzly Catalog to a friend:

| |
|----------------------------------|
| Name _____ |
| Street _____ |
| City _____ State _____ Zip _____ |

TAPE ALONG EDGES--PLEASE DO NOT STAPLE