

Grizzly *Industrial, Inc.*®

MODEL G7151 HAND PUNCHER OWNER'S MANUAL



COPYRIGHT © OCTOBER, 2008 BY GRIZZLY INDUSTRIAL, INC. REVISED JANUARY, 2009 (JB)

**WARNING: NO PORTION OF THIS MANUAL MAY BE REPRODUCED IN ANY SHAPE
OR FORM WITHOUT THE WRITTEN APPROVAL OF GRIZZLY INDUSTRIAL, INC.**

#JB11066 PRINTED IN CHINA



WARNING!

This manual provides critical safety instructions on the proper setup, operation, maintenance and service of this machine/equipment.

Failure to read, understand and follow the instructions given in this manual may result in serious personal injury, including amputation, electrocution or death.

The owner of this machine/equipment is solely responsible for its safe use. This responsibility includes but is not limited to proper installation in a safe environment, personnel training and usage authorization, proper inspection and maintenance, manual availability and comprehension, application of safety devices, blade/cutter integrity, and the usage of personal protective equipment.

The manufacturer will not be held liable for injury or property damage from negligence, improper training, machine modifications or misuse.



WARNING!

Some dust created by power sanding, sawing, grinding, drilling, and other construction activities contains chemicals known to the State of California to cause cancer, birth defects or other reproductive harm. Some examples of these chemicals are:

- **Lead from lead-based paints.**
- **Crystalline silica from bricks, cement and other masonry products.**
- **Arsenic and chromium from chemically-treated lumber.**

Your risk from these exposures varies, depending on how often you do this type of work. To reduce your exposure to these chemicals: Work in a well ventilated area, and work with approved safety equipment, such as those dust masks that are specially designed to filter out microscopic particles.

Table of Contents

- INTRODUCTION..... 2**
 - Manual Accuracy..... 2
 - Contact Info..... 2
 - Functional Overview..... 2
 - Identification..... 3
 - Machine Data Sheet..... 4

- SECTION 1: SAFETY 5**
 - Safety Instructions for Machinery..... 5
 - Additional Safety Instructions for Punches 7

- SECTION 2: SETUP 8**
 - Setup Safety..... 8
 - Items Needed for Setup 8
 - Unpacking 8
 - Inventory..... 9
 - Hardware Recognition Chart..... 10
 - Clean Up 11
 - Site Considerations 11
 - Assembly..... 12
 - Mounting..... 12

- SECTION 3: OPERATIONS 13**
 - Operation Safety 13
 - Basic Controls 13
 - Punching 14
 - Work Stops..... 14
 - Punch & Die Replacement..... 15

- SECTION 4: ACCESSORIES 16**

- SECTION 5: MAINTENANCE..... 19**
 - Schedule 19
 - Cleaning 19
 - Unpainted Surfaces..... 19
 - Lubrication..... 19

- SECTION 6: SERVICE 20**
 - Troubleshooting..... 20

- SECTION 7: PARTS..... 21**
 - Parts Breakdown..... 21
 - Labels Breakdown & List..... 22

- WARRANTY AND RETURNS 25**

INTRODUCTION

Manual Accuracy

We are proud to offer this manual with your new machine! We've made every effort to be exact with the instructions, specifications, drawings, and photographs of the machine we used when writing this manual. However, sometimes errors do happen and we apologize for them.

Also, owing to our policy of continuous improvement, **your machine may not exactly match the manual.** If you find this to be the case, and the difference between the manual and machine leaves you in doubt, immediately call our technical support for updates or clarification.

For your convenience, we always keep current Grizzly manuals and most updates available on our website at www.grizzly.com. Any updates to your machine will be reflected in these documents as soon as they are complete. Visit our site often to check for the latest updates!

Contact Info

We stand behind our machines. If you have any service questions, parts requests or general questions about the machine, please call or write us at the location listed below.

Grizzly Industrial, Inc.
1203 Lycoming Mall Circle
Muncy, PA 17756
Phone: (570) 546-9663
Fax: (800) 438-5901
E-Mail: techsupport@grizzly.com

If you have any comments regarding this manual, please write to us at the address below:

Grizzly Industrial, Inc.
c/o Technical Documentation Manager
P.O. Box 2069
Bellingham, WA 98227-2069
Email: manuals@grizzly.com

Functional Overview

The Model G7151 Hand Puncher is used to punch holes in mild steel up to $\frac{3}{16}$ " thick. It consists of a steel body, a punch and die set, leverage multiplying linkage, and a handle.

To punch holes, the operator places the workpiece between the punch and die. If desired, the work stop can be used for consistent hole locations during repetitive punching operations. The handle is used to lower the punch through the workpiece. Once the punch is complete, the operator returns the handle to the up-most position to retract the punch from the workpiece.

If additional leverage is required, the handle extension can be attached to the handle.

Additional punch and die sets are available for creating a variety of hole sizes from $\frac{1}{8}$ "– $\frac{5}{8}$ ".



Identification

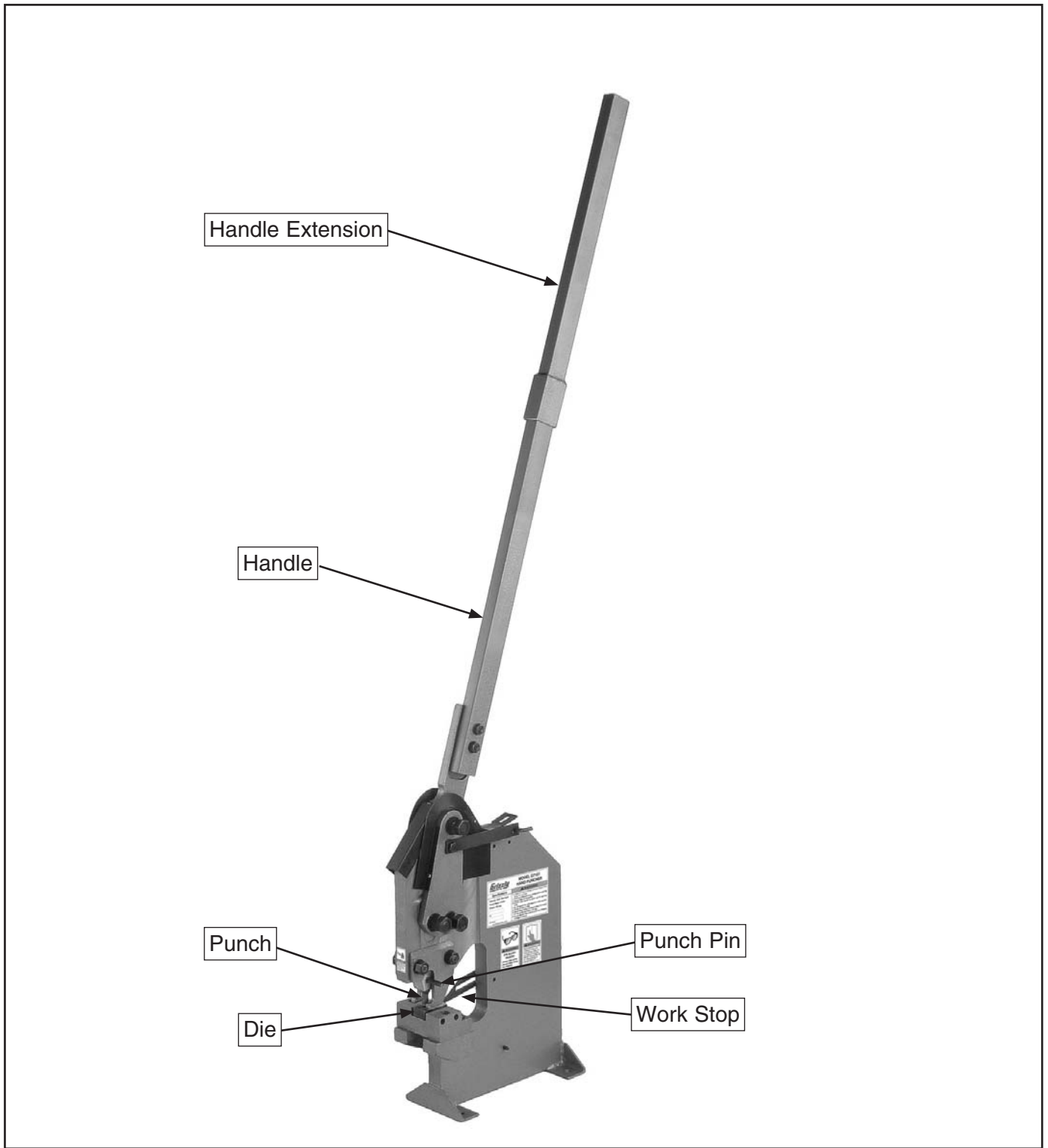

Figure 1. Identification.





MACHINE DATA SHEET

Customer Service #: (570) 546-9663 • To Order Call: (800) 523-4777 • Fax #: (800) 438-5901

MODEL G7151 HAND PUNCHER

Product Dimensions:

Weight 168 lbs.
Length/Width/Height 17" x 6½" x 81"
Footprint (Length/Width) 6½" x 13¾"

Shipping Dimensions:

Type Wood Crate
Content Machine
Weight 194 lbs.
Length/Width/Height 36½" x 20¾" x 9"

Capacities:

Maximum Thickness 3/16" Mild Steel
Notch Stroke 3/4"

Construction

Punch and Die Hardened Steel
Frame Cast Iron

Other Specifications:

Country Of Origin China
Warranty 1 Year
Serial Number Location ID Label on Side of Machine
Assembly Time 15 minutes

Features:

- Extra Long Handle for Increased Leverage
- Replaceable Punches and Dies
- Work Stop for Repetitive Operations
- Heavy-Duty Cast Iron Construction



SECTION 1: SAFETY

WARNING

For Your Own Safety, Read Instruction Manual Before Operating this Machine

The purpose of safety symbols is to attract your attention to possible hazardous conditions. This manual uses a series of symbols and signal words intended to convey the level of importance of the safety messages. The progression of symbols is described below. Remember that safety messages by themselves do not eliminate danger and are not a substitute for proper accident prevention measures.



Indicates an imminently hazardous situation which, if not avoided, **WILL** result in death or serious injury.



Indicates a potentially hazardous situation which, if not avoided, **COULD** result in death or serious injury.



Indicates a potentially hazardous situation which, if not avoided, **MAY** result in minor or moderate injury. It may also be used to alert against unsafe practices.

NOTICE

This symbol is used to alert the user to useful information about proper operation of the machine.

WARNING

Safety Instructions for Machinery

- 1. READ THE ENTIRE MANUAL BEFORE STARTING MACHINERY.** Machinery presents serious injury hazards to untrained users.
- 2. ALWAYS USE ANSI APPROVED SAFETY GLASSES WHEN OPERATING MACHINERY.** Everyday eyeglasses only have impact resistant lenses—they are NOT safety glasses.
- 3. ALWAYS WEAR A NIOSH APPROVED RESPIRATOR WHEN OPERATING MACHINERY THAT PRODUCES DUST.** Most types of dust (wood, metal, etc.) can cause severe respiratory illnesses.
- 4. ALWAYS USE HEARING PROTECTION WHEN OPERATING MACHINERY.** Machinery noise can cause permanent hearing loss.
- 5. WEAR PROPER APPAREL. DO NOT** wear loose clothing, gloves, neckties, rings, or jewelry that can catch in moving parts. Wear protective hair covering to contain long hair and wear non-slip footwear.
- 6. NEVER OPERATE MACHINERY WHEN TIRED OR UNDER THE INFLUENCE OF DRUGS OR ALCOHOL.** Be mentally alert at all times when running machinery.



WARNING

Safety Instructions for Machinery

7. **ONLY ALLOW TRAINED AND PROPERLY SUPERVISED PERSONNEL TO OPERATE MACHINERY.** Make sure operation instructions are safe and clearly understood.
8. **KEEP CHILDREN AND VISITORS AWAY.** Keep all children and visitors a safe distance from the work area.
9. **MAKE WORKSHOP CHILDPROOF.** Use padlocks, master switches, and remove start switch keys.
10. **NEVER LEAVE WHEN MACHINE IS RUNNING.** Turn power **OFF** and allow all moving parts to come to a complete stop before leaving machine unattended.
11. **DO NOT USE IN DANGEROUS ENVIRONMENTS.** DO NOT use machinery in damp, wet locations, or where any flammable or noxious fumes may exist.
12. **KEEP WORK AREA CLEAN AND WELL LIGHTED.** Clutter and dark shadows may cause accidents.
13. **USE A GROUNDED EXTENSION CORD RATED FOR THE MACHINE AMPERAGE.** Grounded cords minimize shock hazards. Undersized cords create excessive heat. Always replace damaged extension cords.
14. **ALWAYS DISCONNECT FROM POWER SOURCE BEFORE SERVICING MACHINERY.** Make sure switch is in OFF position before reconnecting.
15. **MAINTAIN MACHINERY WITH CARE.** Keep blades sharp and clean for best and safest performance. Follow instructions for lubricating and changing accessories.
16. **MAKE SURE GUARDS ARE IN PLACE AND WORK CORRECTLY BEFORE USING MACHINERY.**
17. **REMOVE ADJUSTING KEYS AND WRENCHES.** Make a habit of checking for keys and adjusting wrenches before turning machinery **ON**.
18. **CHECK FOR DAMAGED PARTS BEFORE USING MACHINERY.** Check for binding or misaligned parts, broken parts, loose bolts, and any other conditions that may impair machine operation. Repair or replace damaged parts before operation.
19. **USE RECOMMENDED ACCESSORIES.** Refer to the instruction manual for recommended accessories. Improper accessories increase risk of injury.
20. **DO NOT FORCE MACHINERY.** Work at the speed for which the machine or accessory was designed.
21. **SECURE WORKPIECE.** Use clamps or a vise to hold the workpiece when practical. A secured workpiece protects your hands and frees both hands to operate the machine.
22. **DO NOT OVERREACH.** Maintain stability and balance at all times.
23. **MANY MACHINES CAN EJECT WORKPIECES TOWARD OPERATOR.** Know and avoid conditions that cause the workpiece to "kickback."
24. **ALWAYS LOCK MOBILE BASES (IF USED) BEFORE OPERATING MACHINERY.**
25. **CERTAIN DUST MAY BE HAZARDOUS** to the respiratory systems of people and animals, especially fine dust. Be aware of the type of dust you are exposed to and always wear a respirator designed to filter that type of dust.



WARNING

Additional Safety Instructions for Punches

- 1. HANDS AND FINGERS.** Always keep hands and fingers away from the punch during operations. If hands or fingers are in the path of the punch during use, severe injury may occur.
- 2. OPERATOR POSITION.** Keep all body parts out of the way of all moving parts. Serious pinches and cuts could occur.
- 3. CAPACITY.** Never exceed the rated capacity for this punch. Doing so could result in machine failure and bodily injury as a result of flying debris or sudden movement.
- 4. COMFORTABLE CUTTING OPERATIONS.** Avoid awkward operations and hand positions where a sudden slip could cause your hand or body to fall into a sharp edge or corner.
- 5. EXPERIENCING DIFFICULTIES.** If at any time you are experiencing difficulties performing the intended operation, stop using the puncher! Contact Tech Support at (570) 546-9663.

WARNING

Like all machinery there is potential danger when operating this machine. Accidents are frequently caused by lack of familiarity or failure to pay attention. Use this machine with respect and caution to lessen the possibility of operator injury. If normal safety precautions are overlooked or ignored, serious personal injury may occur.

CAUTION

No list of safety guidelines can be complete. Every shop environment is different. Always consider safety first, as it applies to your individual working conditions. Use this and other machinery with caution and respect. Failure to do so could result in serious personal injury, damage to equipment, or poor work results.



SECTION 2: SETUP

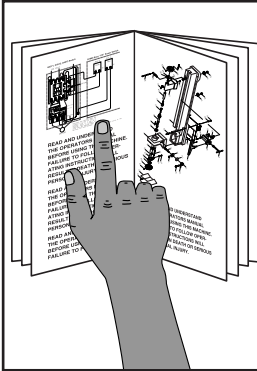

!WARNING

This machine presents serious injury hazards to untrained users. Read through this entire manual to become familiar with the controls and operations before operating the machine!

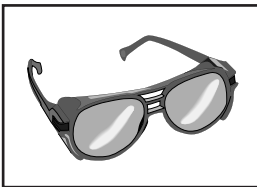

!WARNING

Wear safety glasses during the entire setup process!

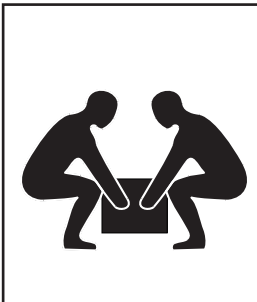

!WARNING

This machine and its components are very heavy. Get lifting help or use power lifting equipment such as a forklift to move heavy items.

Items Needed for Setup

The following items are needed to complete the setup process, but are not included with your machine:

Description	Qty
• Safety Glasses	1
• Wrenches 19mm	2
• Mounting Hardware	As needed

Unpacking

Your machine was carefully packaged for safe transportation. Remove the packaging materials from around your machine and inspect it. If you discover the machine is damaged, *please immediately call Customer Service at (570) 546-9663 for advice.*

Save the containers and all packing materials for possible inspection by the carrier or its agent. *Otherwise, filing a freight claim can be difficult.*

When you are completely satisfied with the condition of your shipment, inventory the contents.



Inventory

The following is a description of the main components shipped with your machine. Lay the components out to inventory them.

Note: *If you can't find an item on this list, check the mounting location on the machine or examine the packaging materials carefully. Occasionally we pre-install certain components for shipping purposes.*

Inventory: (Figure 2)	Qty
A. Hand Puncher	1
B. Handle Extension	1
C. Handle	1
D. Hex Bolts M12-1.75 x 55 (handle).....	2
E. Flat Washers 12mm (handle)	4
F. Hex Nuts M12-1.75 (handle)	2

If any nonproprietary parts are missing (e.g. a nut or a washer), we will gladly replace them; or for the sake of expediency, replacements can be obtained at your local hardware store.

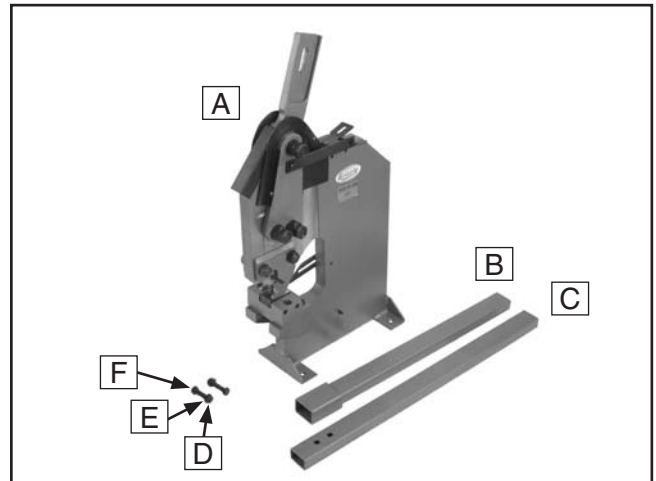

Figure 2. Inventory.

	<p>! WARNING SUFFOCATION HAZARD! Immediately discard all plastic bags and packing materials to eliminate choking/suffocation hazards for children and animals.</p>
--	--



Hardware Recognition Chart

USE THIS CHART TO MATCH UP HARDWARE DURING THE ASSEMBLY PROCESS.

MEASURE BOLT DIAMETER BY PLACING INSIDE CIRCLE

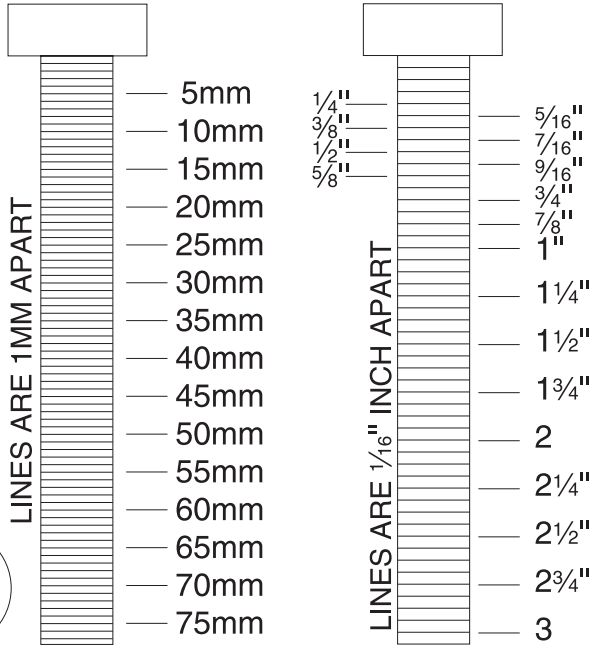
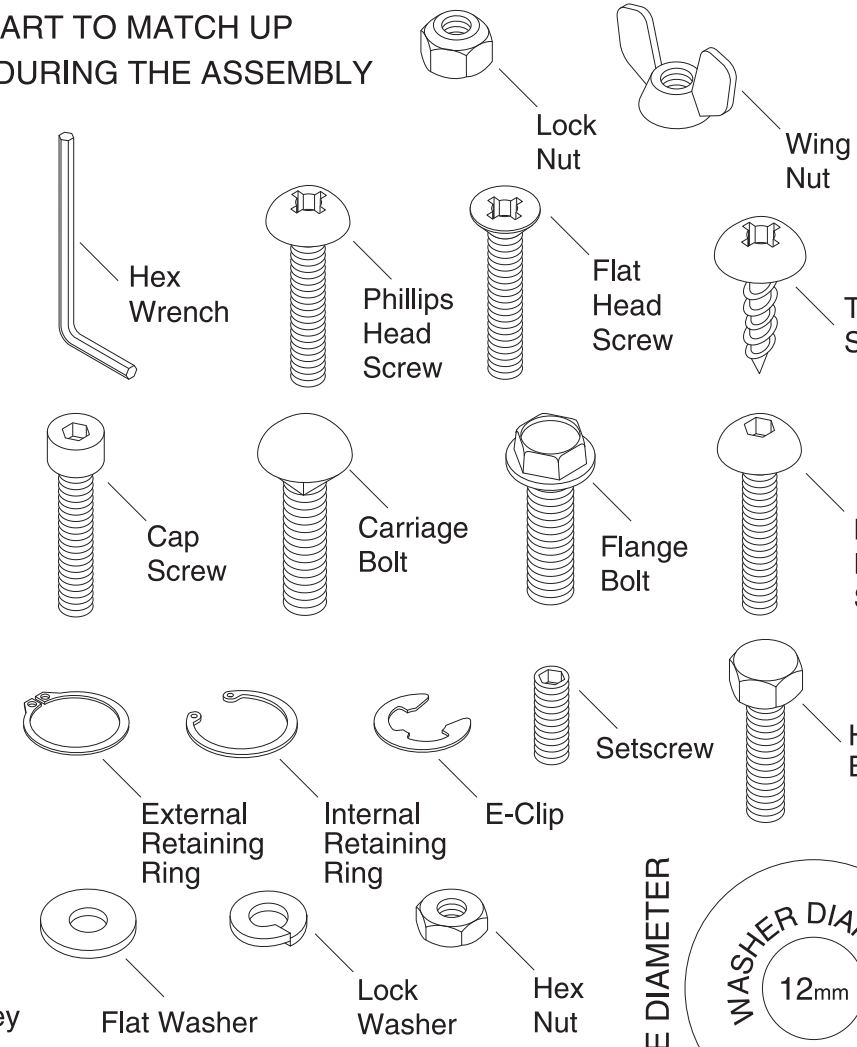
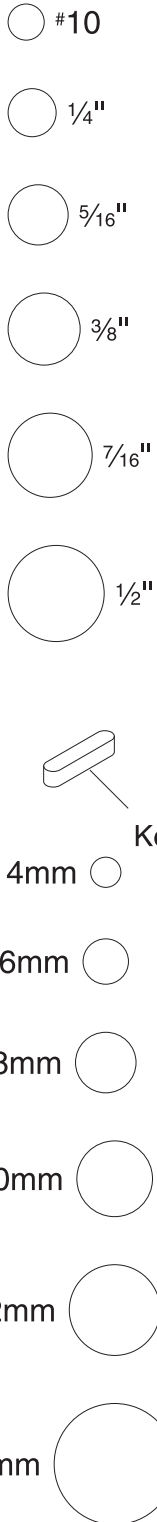

WASHERS ARE MEASURED BY THE INSIDE DIAMETER

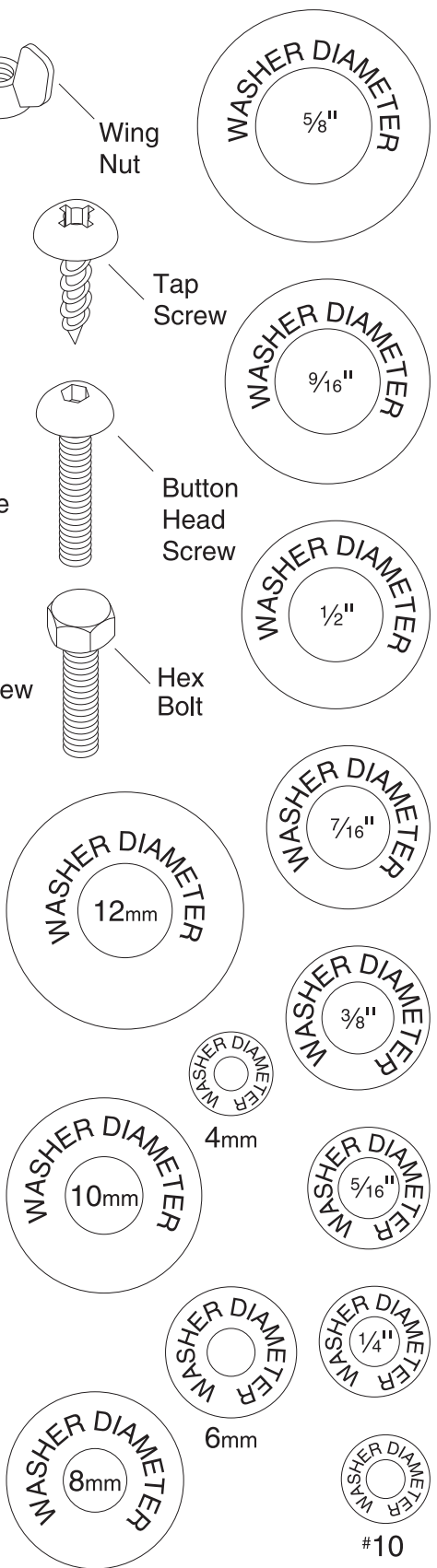

Clean Up

The unpainted surfaces are coated with a waxy oil to prevent corrosion during shipment. Remove this protective coating with a solvent cleaner or degreaser, such as shown in **Figure 3**. For thorough cleaning, some parts must be removed. **For optimum performance, clean all moving parts or sliding contact surfaces.** Avoid chlorine-based solvents, such as acetone or brake parts cleaner that may damage painted surfaces. Always follow the manufacturer's instructions when using any type of cleaning product.

	<p>! WARNING Gasoline and petroleum products have low flash points and can explode or cause fire if used to clean machinery. DO NOT use these products to clean the machinery.</p>
---	--

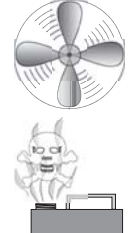
	<p>! CAUTION Many cleaning solvents are toxic if inhaled. Minimize your risk by only using these products in a well ventilated area.</p>
---	---

G2544—Solvent Cleaner & Degreaser
H9692—Orange Power Degreaser
Great products for removing shipping grease.

<p>Call 1-800-523-4777 To Order</p>	
--	---

Figure 3. Cleaner/degreasers available from Grizzly.

Site Considerations

Workbench Load

Refer to the **Machine Data Sheet** for the weight and footprint specifications of your machine. Some workbenches may require additional reinforcement to support the machine, workpiece and the forces applied during use.

Placement Location

Consider existing and anticipated needs, size of material to be processed through each machine, and space for auxiliary stands, work tables or other machinery when establishing a location for your new machine. See **Figure 4** for the minimum working clearances.

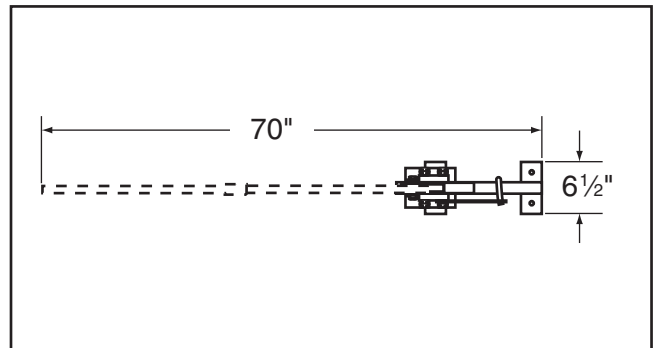
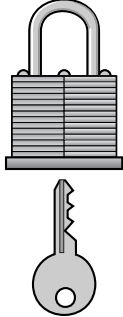

Figure 4. Minimum working clearances.

	<p>! CAUTION Children and visitors may be seriously injured if unsupervised around this machine. Lock entrances to the shop or disable start switch or power connection to prevent unsupervised use.</p>
--	---



Assembly

To assemble the hand puncher:

1. Attach the handle to the handle base with the M12-1.75 x 55 hex bolts, 12mm flat washers and M12-1.75 lock nuts, as shown in **Figure 5**.

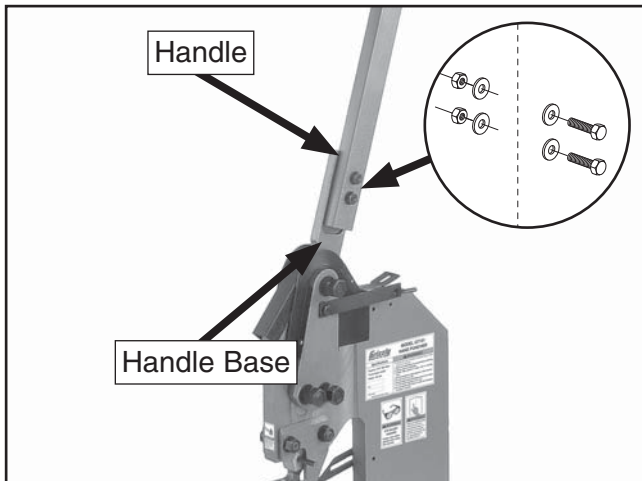

Figure 5. Attaching handle.

2. Slide the handle extension over the handle.

Note: *This step is optional and is not be necessary for all operations. Only use the handle extension when it is needed for additional leverage.*

Mounting

For safe and effective operations, the Model G7151 must be mounted to a workbench through the holes in the base.

The strongest mounting option is a "Through Mount" where holes are drilled all the way through the workbench, and hex bolts, washers, and hex nuts are used to secure the drill press to the workbench.

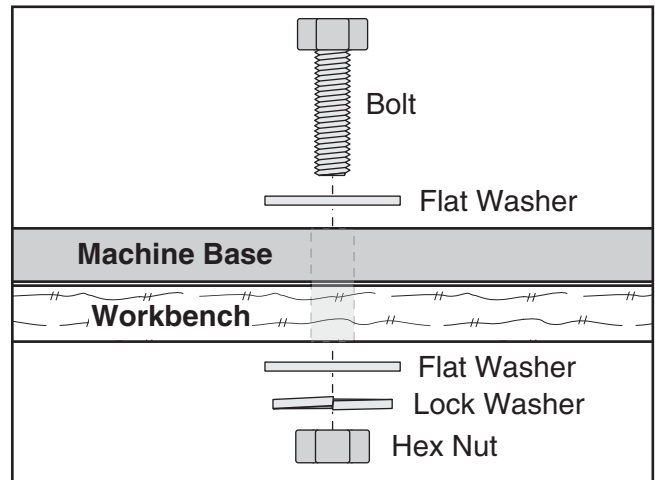

Figure 6. Example of a through mount setup.

Another option for mounting is a "Direct Mount" where the machine is simply secured to the workbench with a lag screw.

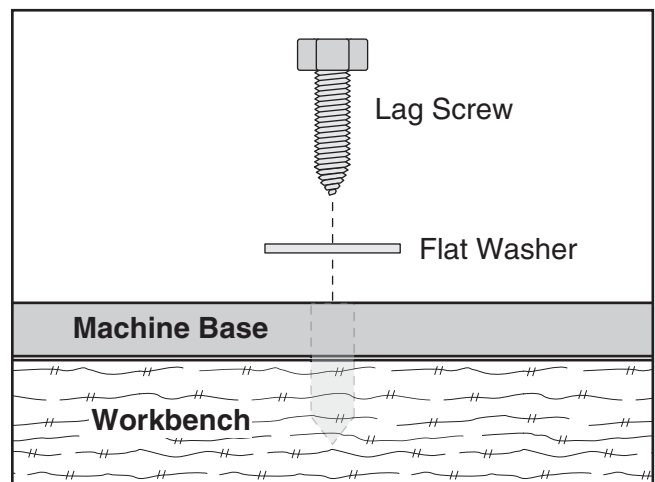
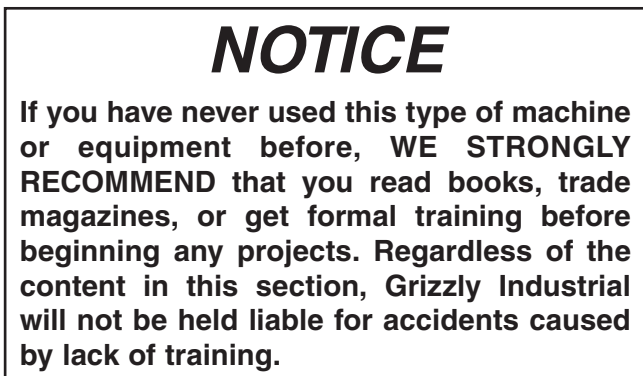
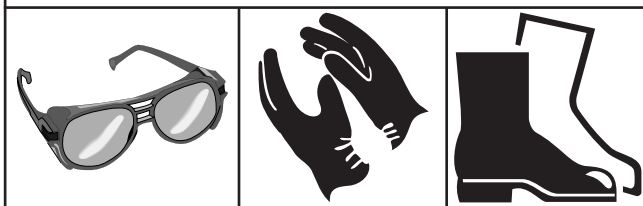
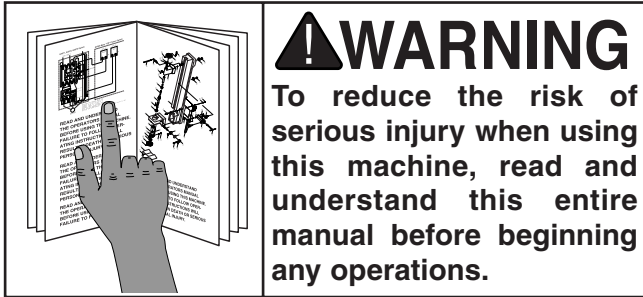

Figure 7. Example of a direct mount setup.



SECTION 3: OPERATIONS



Basic Controls

Use the descriptions below and **Figure 8** to become familiar with the basic controls of your machine.

Handle (Not shown): When lowered, forces the punch through the workpiece and into the die.

Punch Pin: Secures the punch. Removal allows for changing of the punch.

Die Adjustment Bolts: Adjusts the position of the die so it can be aligned with the punch.

Work Stop: Easily aligns the workpiece for making repetitive punches.

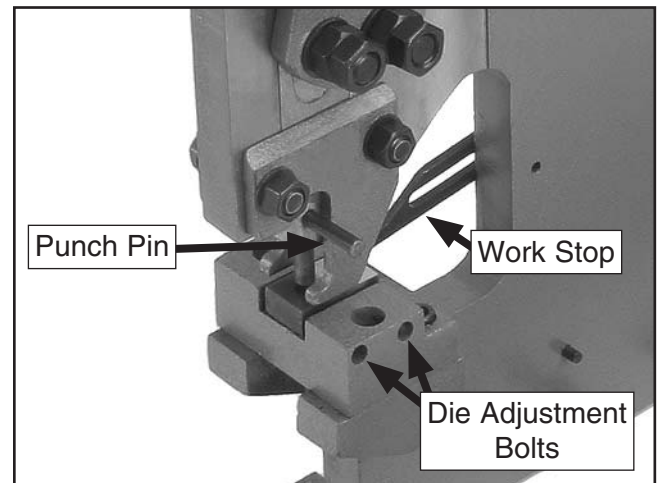

Figure 8. Adjustment knobs.



Punching

When punching with the Model G7151, the waste from the punching operation will be ejected from the bottom of the machine.

To use the machine:

1. Wearing gloves and safety glasses or a face shield, place the workpiece between the punch and die, lining it up with the punch centerpoint as needed.

CAUTION

Injury to your feet could result when material is ejected from the bottom of the machine. Always wear heavy-toed leather footwear when operating this machine.

NOTICE

Only use the Model G7151 as it was designed. Use of a cheater bar other than the included handle extension may exceed the machine capacities, resulting in possible failure and personal injury, and will void the warranty.

2. Pull the handle down to move the punch into and through the workpiece. Continue pulling until the punch is complete.
3. Lift the handle back to the uppermost position, then remove the workpiece.

Work Stops

The Model G7151 has an adjustable stop attached to the work table. This allows rapid alignment of workpieces for repetitive operations.

To use the work stop:

1. Align the workpiece as necessary on the table and make the desired cut. Check that the cut meets your requirements.
2. Once the cut is to your standards, lower the handle so that the punch goes through the hole you just made and into the die below (Figure 9).

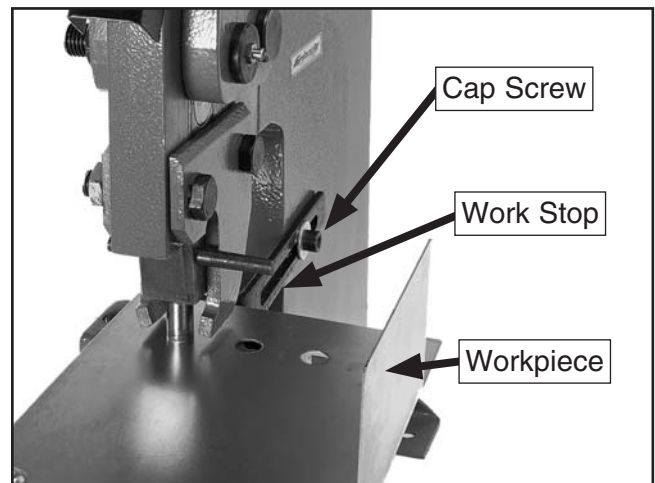

Figure 9. Work stops.

3. Adjust the work stop as necessary to provide adequate support and proper alignment with the workpiece, then tighten the cap screw (Figure 9).
4. Return the handle to the uppermost position and remove the workpiece.
5. For punching additional holes, place the workpiece against the work stop and make the punch.



Punch & Die Replacement

If you need to change the size of the holes being punched or if the punch or die has become worn, you must replace the punch and die.

To change the punch and die:

1. Loosen the die adjustment bolts and remove the die (**Figure 10**).

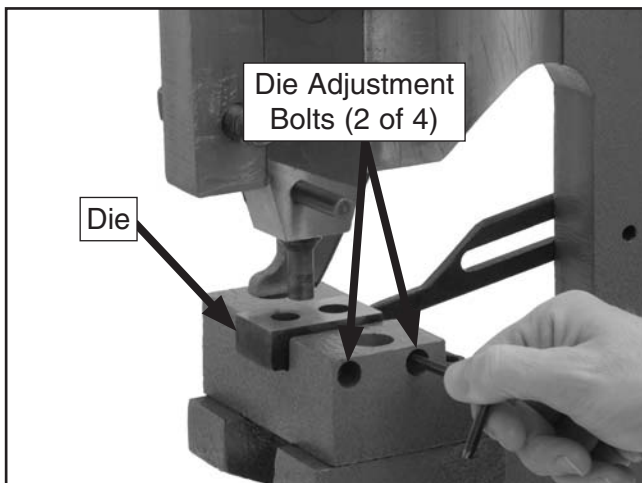

Figure 10. Die removal (side plate removed for clarity).

2. Tap the punch pin until it moves freely, but do not fully remove it (**Figure 11**).

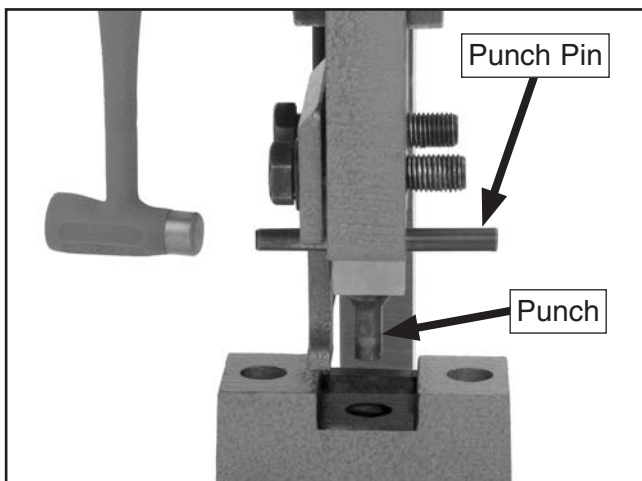

Figure 11. Punch pin removal (side plate removed for clarity).

3. Hold the punch with a rag or gloves, then fully remove the punch pin to release the punch.

4. Slide the new punch into the machine, then replace the punch pin to secure the punch. Align the flat portions of the punch and punch pin. Use gloves or a rag and pliers to hold the punch during installation (**Figure 12**).

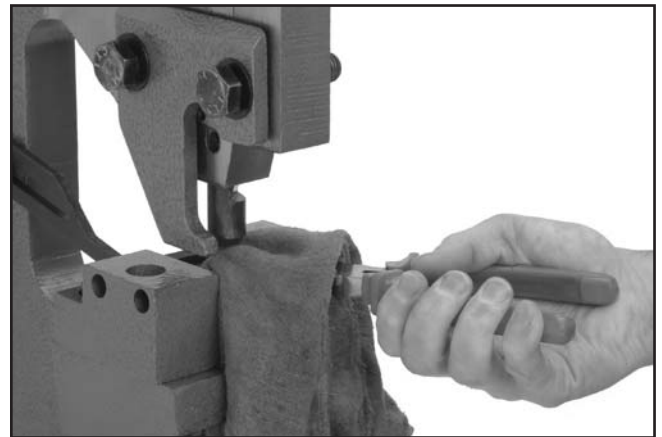

Figure 12. Installing punch.

5. Place the new die into the machine, then lower the handle while adjusting the position of the die so that the punch fits into the die (**Figure 13**).

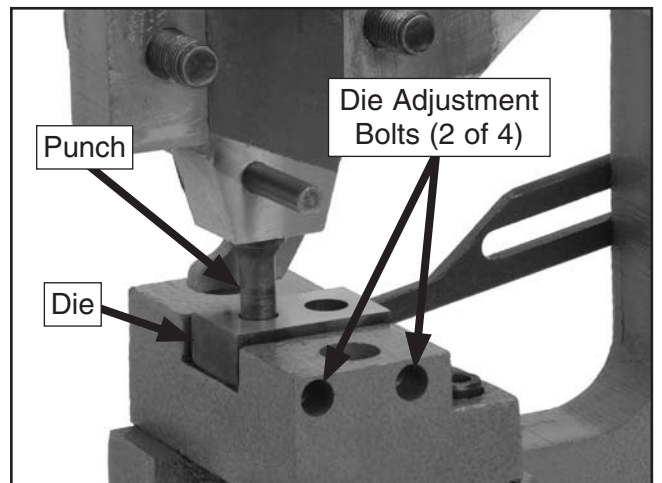

Figure 13. Punch and die alignment (side plate removed for clarity).

6. Carefully tighten the die adjustment bolts so that the die is secured while remaining centered around the punch.

Note: Pay close attention to the alignment of the die and punch while tightening the die adjustment bolts. If you overtighten one of the bolts, you will force the die against the punch, causing damage to the machine.



SECTION 4: ACCESSORIES

G8032— $\frac{1}{8}$ " Punch & Die for G7151 Puncher
G8033— $\frac{3}{16}$ " Punch & Die for G7151 Puncher
G8034— $\frac{1}{4}$ " Punch & Die for G7151 Puncher
G8035— $\frac{5}{16}$ " Punch & Die for G7151 Puncher
G8040— $\frac{3}{8}$ " Punch & Die for G7151 Puncher
G8041— $\frac{7}{16}$ " Punch & Die for G7151 Puncher
G8042— $\frac{1}{2}$ " Punch & Die for G7151 Puncher
G8043— $\frac{9}{16}$ " Punch & Die for G7151 Puncher
G8044— $\frac{5}{8}$ " Punch & Die for G7151 Puncher
 Increase the hole punching versatility of the G7151 Hand Puncher with these optional punch & die sets. Easy installation takes just seconds to swap out die sizes.



Figure 14. Replacement punch & die sets.

G5618—Deburring Tool with two Blades
 The quickest tool for smoothing freshly sheared metal edges. Comes with two blades, one for steel and aluminum and one for brass and cast iron.



Figure 15. Model G5618 Deburring tool.

H6073—Deluxe Power Snip
 Lightweight aluminum cast handles. Full $3\frac{1}{2}$ " length of cut. Replaceable steel blades. Fully enclosed finger loops protect hands from sharp edges. Long handles provide plenty of leverage. Multi-purpose snip for sheet metal, vinyl and plastic.



Figure 16. Model H6073 Deluxe Power Snip.

G5562—SLIPIT® 1 Qt. Gel
G5563—SLIPIT® 12 oz Spray
G2871—Boeshield® T-9 12 oz Spray
G2870—Boeshield® T-9 4 oz Spray
H3788—G96® Gun Treatment 12 oz Spray
H3789—G96® Gun Treatment 4.5 oz Spray



Figure 17. Recommended products for protecting unpainted cast iron/steel part on machinery.

Call 1-800-523-4777 To Order



G4956—Super Nibbler

The super nibbler is just the ticket for cutting sheet metal up to $\frac{3}{64}$ " thick. Extremely narrow headed design allows cuts in hard-to-reach areas, yet still features a safety guard to prevent flying splinters. 10 $\frac{1}{4}$ " overall.



Figure 18. Model G4956 Super Nibbler.

H5958—Sheet Metal Pliers

For bending and forming sheet metal. Jaws are 3 $\frac{1}{2}$ " wide. Rubber grips. Overall length is 8". Ideal for HVAC Installers.

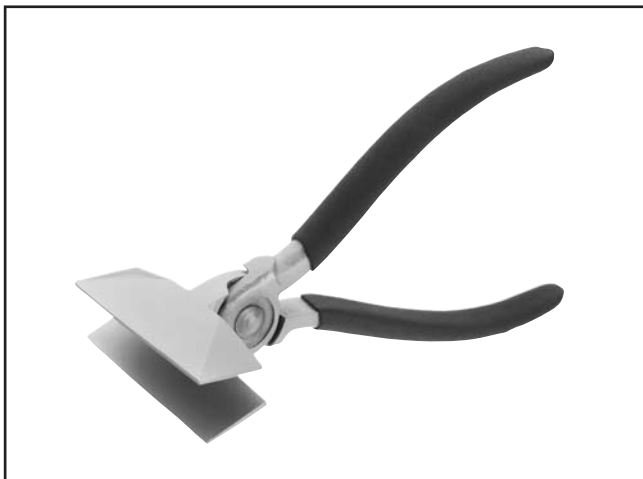

Figure 19. Model H5958 Sheet Metal Pliers.

Call 1-800-523-4777 To Order

G8781—4 $\frac{1}{2}$ " Suction Cup

Handle plate glass, glass mirrors and sheet metal with safety and security. Simple hand lever action provides tremendous gripping power on any flat, smooth material. Buy two Suction Cups for two-handed control!

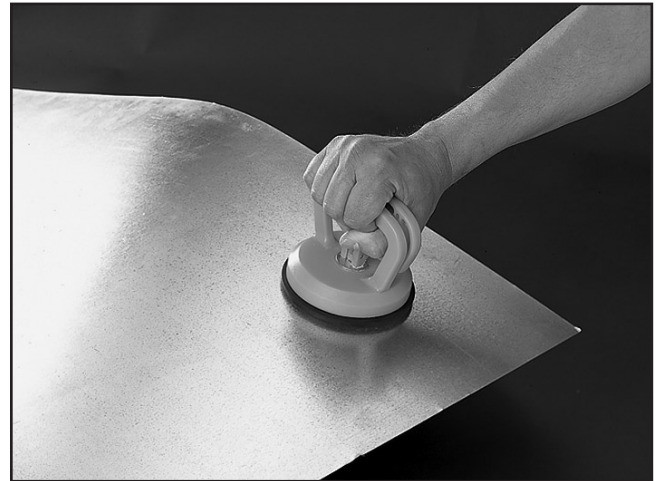

Figure 20. Model G8781 4 $\frac{1}{2}$ " Suction Cup.

H6131—Heavy-Duty Hand Riveter

Whether you're a full time sheet metal fabricator, or just making occasional repairs, you might as well invest in the best. This Heavy-Duty Hand Riveter with reinforced cast construction will be one of your most dependable tools.



Figure 21. Model H6131 Heavy-Duty Hand Riveter.



- T20501—Face Shield Crown Protector 4"**
- T20502—Face Shield Crown Protector 7"**
- T20503—Face Shield Window**
- T20448—Economy Clear Safety Glasses**
- T20452—"Kirova" Anti-Reflective Glasses**
- T20456—"Dakura" Clear Safety Glasses**
- H0736—Shop Fox® Safety Glasses**

These glasses meet ANSI Z87.1-2003 specifications. Buy extras for visitors or employees. You can't be too careful with shop safety!



Figure 22. Our most popular eye protection.

H5614—Wire Gauge US Standard

Calibrated for sheet metal sized from 0 to 30 gauge. The front is marked with gauge sizes, the back is marked with actual inch measurements.



Figure 23. H5614 Wire Gauge.

T20640—Machinery's Handbook

For more than 90 years, this handbook has been the benchmark by which machinists' and engineering texts have been judged. Includes a wealth of information on mathematics, mechanics, measurements, and materials. A must have for the amateur or professional.

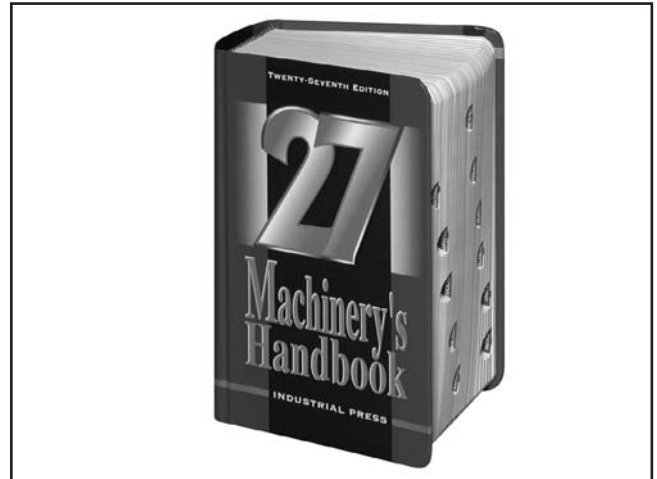

Figure 24. Model T20640 Machinery's Handbook.

H5923—Carbide Scribe

Carbide tipped for marking or etching metal and glass. Ideal for machinists, metalworkers and tinsmiths. Hex shaped with pocket clip. Measures 6" long.



Figure 25. H5923 Carbide Scribe.



SECTION 5: MAINTENANCE

Schedule

For optimum performance from your machine, follow this maintenance schedule and refer to any specific instructions given in this section.

Daily Check:

- Loose mounting bolts.
- Loose handle.
- Any other unsafe condition.
- Worn or damaged punch or die.

Weekly Maintenance:

- Clean machine.
- Lubricate moving parts.

Cleaning

Cleaning the Model G7151 is relatively easy. Periodically wipe down the machine to remove dust and oil. Treat all unpainted surfaces with a non-staining lubricant after cleaning.

Unpainted Surfaces

Protect the unpainted surfaces on the machine by wiping it clean after every use—this ensures rust-promoting debris does not remain on bare metal surfaces.

Keep the machine rust-free with regular applications of products like Boeshield® T-9 (see **Section 4: Accessories** on **Page 16** for more details).

Lubrication

Lubricating the Model G7151 consists of applying lubricant to all of the moving parts (**Figure 26**).

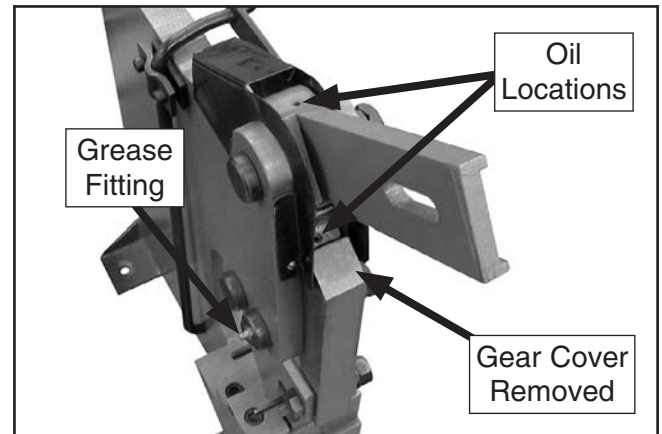

Figure 26. Oil locations.

Oiling Locations

Apply several drops of SAE 30 or equivalent oil from an oil can into the oil holes shown in **Figure 26**. Move the handle back and forth several times to disperse the oil, then wipe off the excess.

Grease Locations

Apply multi-purpose grease from a grease gun to the grease fitting shown in **Figure 26**. Lift the gear cover and brush a light coat of grease to the gear teeth between the handle base and the main body of the machine.



SECTION 6: SERVICE

Review the troubleshooting and procedures in this section to fix or adjust your machine if a problem develops. If you need replacement parts or you are unsure of your repair skills, then feel free to call our Technical Support at (570) 546-9663.

Troubleshooting

Operations

Symptom	Possible Cause	Possible Solution
Heavy resistance is felt when punching is attempted.	<ol style="list-style-type: none">1. Machine capacities are exceeded.2. Punch/Die are dull.3. Die alignment is improperly set.4. Machine needs lubrication.	<ol style="list-style-type: none">1. Use materials within the capacity of the machine.2. Replace punch/die (Page 15).3. Adjust die alignment (Page 15).4. Lubricate machine (Page 19).
Punch is not made cleanly.	<ol style="list-style-type: none">1. Machine capacities are exceeded.2. Punch/Die are dull.3. Die alignment is improperly set.	<ol style="list-style-type: none">1. Use materials within the capacity of the machine.2. Replace punch/die (Page 15).3. Adjust die alignment (Page 15).



SECTION 7: PARTS

Parts Breakdown

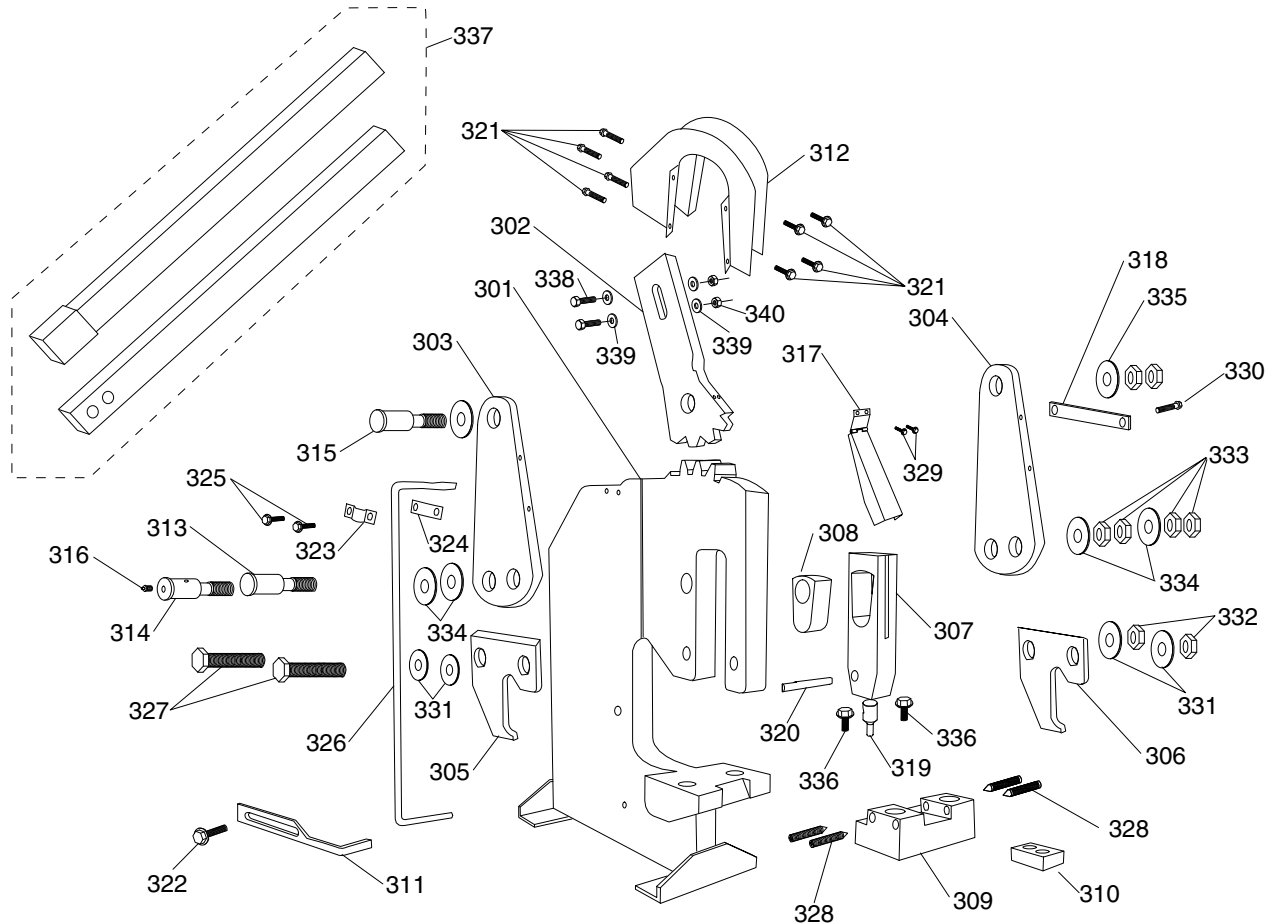

REF	PART #	DESCRIPTION
301	P7151301	BODY
302	P7151302	HANDLE BASE
303	P7151303	JOINTING PLATE LEFT
304	P7151304	JOINTING PLATE RIGHT
305	P7151305	PRESSURE PLATE LEFT
306	P7151306	PRESSURE PLATE RIGHT
307	P7151307	RAM
308	P7151308	ROCKER BLOCK
309	P7151309	TABLE
310	P7151310	DIE
311	P7151311	WORK STOP
312	P7151312	HANDLE BRACKET
313	P7151313	PIVOT PIN
314	P7151314	PORTED PIVOT PIN
315	P7151315	HANDLE PIVOT PIN
316	P7151316	ZERK FITTING
317	P7151317	GEAR COVER
318	P7151318	SPRING PLATE
319	P7151319	PUNCH
320	P7151320	PUNCH PIN
321	PFB08M	FLANGE BOLT M5-.8 X 10
322	PB74M	HEX BOLT M10-1.5 X 20
323	P7151323	SPRING BRACKET (INNER)
324	P7151324	SPRING BRACKET (OUTER)
325	PFB25M	FLANGE BOLT M8-1.25 X 25
326	P7151326	TORSION ROD
327	PB131M	HEX BOLT M16-2 X 70
328	P7151328	SPECIAL SET SCREW
329	PB05M	HEX BOLT M6-1 X 8
330	PFB23M	FLANGE BOLT M10-1.5 X 20
331	PW08M	FLAT WASHER 16MM
332	P7151332	SPECIAL NUT M16
333	P7151333	SPECIAL NUT M20
334	PW13M	FLAT WASHER 20MM
335	PW13M	FLAT WASHER 20MM
336	PB38M	HEX BOLT M12-1.75 X 60
337	P7151337	PIPE HANDLE 2PC SET V2.11.02
338	PB12M	HEX BOLT M12-1.75 x 55
339	PW06M	FLAT WASHER 12MM
340	PN09M	HEX NUT M12-1.75



Labels Breakdown & List

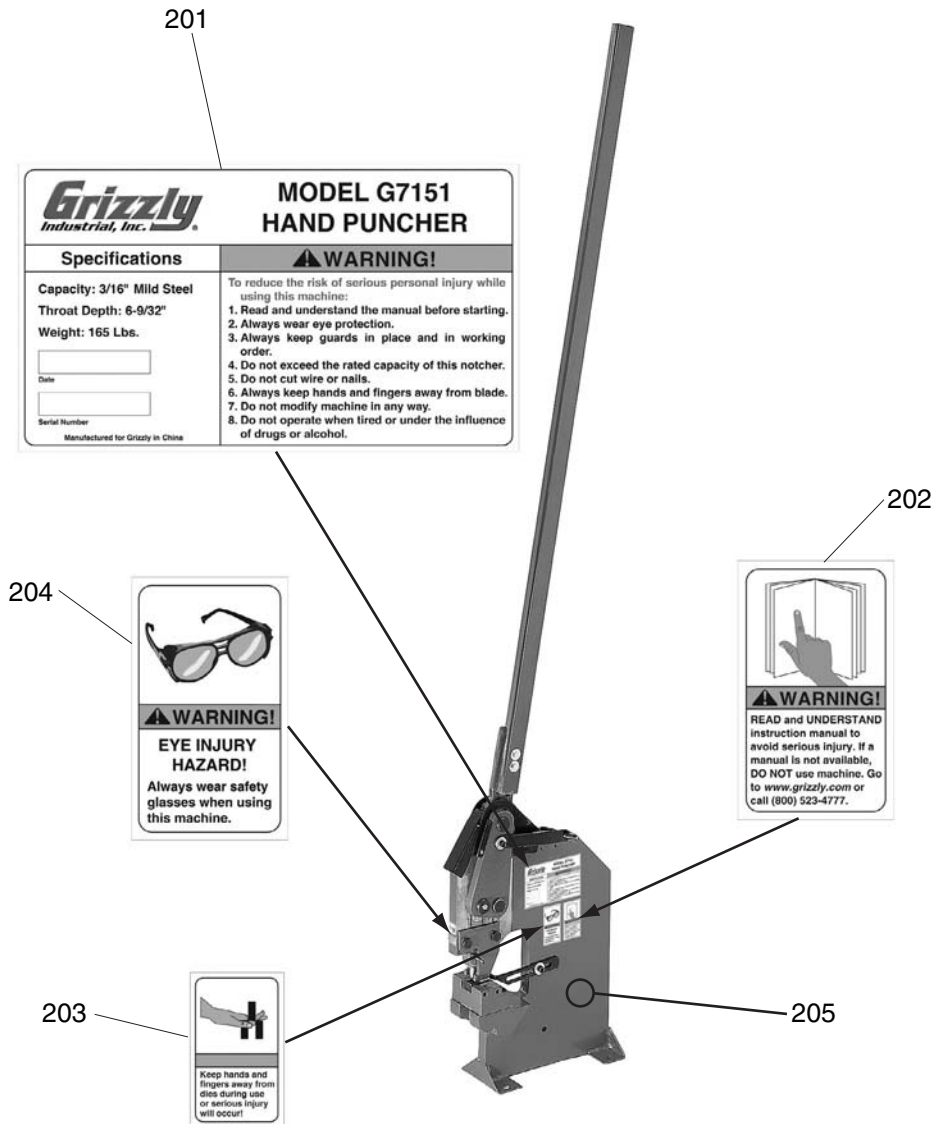

REF	PART #	DESCRIPTION
201	P7151201	MACHINE ID LABEL
202	PLABEL-12A	READ MANUAL LABEL
203	P7151203	PINCHING LABEL

REF	PART #	DESCRIPTION
204	PLABEL-11A	SAFETY GLASSES LABEL
205	PPAINT-1	GREEN TOUCH-UP PAINT

WARNING

Safety labels warn about machine hazards and ways to prevent injury. The owner of this machine **MUST** maintain the original location and readability of the labels on the machine. If any label is removed or becomes unreadable, **REPLACE** that label before using the machine again. Contact Grizzly at (800) 523-4777 or www.grizzly.com to order new labels.





WARRANTY CARD

Name _____

Street _____

City _____ State _____ Zip _____

Phone # _____ Email _____ Invoice # _____

Model # _____ Order # _____ Serial # _____

The following information is given on a voluntary basis. It will be used for marketing purposes to help us develop better products and services. **Of course, all information is strictly confidential.**

1. How did you learn about us?

- Advertisement
- Card Deck
- Friend
- Website
- Catalog
- Other:

2. Which of the following magazines do you subscribe to?

- | | | |
|---|--|---|
| <input type="checkbox"/> Cabinet Maker | <input type="checkbox"/> Popular Mechanics | <input type="checkbox"/> Today's Homeowner |
| <input type="checkbox"/> Family Handyman | <input type="checkbox"/> Popular Science | <input type="checkbox"/> Wood |
| <input type="checkbox"/> Hand Loader | <input type="checkbox"/> Popular Woodworking | <input type="checkbox"/> Wooden Boat |
| <input type="checkbox"/> Handy | <input type="checkbox"/> Practical Homeowner | <input type="checkbox"/> Woodshop News |
| <input type="checkbox"/> Home Shop Machinist | <input type="checkbox"/> Precision Shooter | <input type="checkbox"/> Woodsmith |
| <input type="checkbox"/> Journal of Light Cont. | <input type="checkbox"/> Projects in Metal | <input type="checkbox"/> Woodwork |
| <input type="checkbox"/> Live Steam | <input type="checkbox"/> RC Modeler | <input type="checkbox"/> Woodworker West |
| <input type="checkbox"/> Model Airplane News | <input type="checkbox"/> Rifle | <input type="checkbox"/> Woodworker's Journal |
| <input type="checkbox"/> Modeltec | <input type="checkbox"/> Shop Notes | <input type="checkbox"/> Other: |
| <input type="checkbox"/> Old House Journal | <input type="checkbox"/> Shotgun News | |

3. What is your annual household income?

- \$20,000-\$29,000
- \$30,000-\$39,000
- \$40,000-\$49,000
- \$50,000-\$59,000
- \$60,000-\$69,000
- \$70,000+

4. What is your age group?

- 20-29
- 30-39
- 40-49
- 50-59
- 60-69
- 70+

5. How long have you been a woodworker/metalworker?

- 0-2 Years
- 2-8 Years
- 8-20 Years
- 20+ Years

6. How many of your machines or tools are Grizzly?

- 0-2
- 3-5
- 6-9
- 10+

7. Do you think your machine represents a good value? Yes No

8. Would you recommend Grizzly Industrial to a friend? Yes No

9. Would you allow us to use your name as a reference for Grizzly customers in your area?
Note: We never use names more than 3 times. Yes No

10. Comments: _____

CUT ALONG DOTTED LINE

FOLD ALONG DOTTED LINE



Place
Stamp
Here



GRIZZLY INDUSTRIAL, INC.
P.O. BOX 2069
BELLINGHAM, WA 98227-2069



FOLD ALONG DOTTED LINE

Send a Grizzly Catalog to a friend:

Name _____
Street _____
City _____ State _____ Zip _____

TAPE ALONG EDGES--PLEASE DO NOT STAPLE

WARRANTY AND RETURNS

Grizzly Industrial, Inc. warrants every product it sells for a period of **1 year** to the original purchaser from the date of purchase. This warranty does not apply to defects due directly or indirectly to misuse, abuse, negligence, accidents, repairs or alterations or lack of maintenance. This is Grizzly's sole written warranty and any and all warranties that may be implied by law, including any merchantability or fitness, for any particular purpose, are hereby limited to the duration of this written warranty. We do not warrant or represent that the merchandise complies with the provisions of any law or acts unless the manufacturer so warrants. In no event shall Grizzly's liability under this warranty exceed the purchase price paid for the product and any legal actions brought against Grizzly shall be tried in the State of Washington, County of Whatcom.

We shall in no event be liable for death, injuries to persons or property or for incidental, contingent, special, or consequential damages arising from the use of our products.

To take advantage of this warranty, contact us by mail or phone and give us all the details. We will then issue you a "Return Number," which must be clearly posted on the outside as well as the inside of the carton. We will not accept any item back without this number. Proof of purchase must accompany the merchandise.

The manufacturers reserve the right to change specifications at any time because they constantly strive to achieve better quality equipment. We make every effort to ensure that our products meet high quality and durability standards and we hope you never need to use this warranty.

Please feel free to write or call us if you have any questions about the machine or the manual.

Thank you again for your business and continued support. We hope to serve you again soon.

grizzly.com

TOOL WEBSITE

Buy Direct and Save with Grizzly® – Trusted, Proven and a Great Value!

*Visit Our Website Today And Discover
Why Grizzly® Is The Industry Leader!*

- SECURE ORDERING
- ORDERS SHIPPED WITHIN 24 HOURS
- E-MAIL RESPONSE WITHIN ONE HOUR

-OR-

Call Today For A **FREE**
Full Color Catalog

1-800-523-4777

