

Grizzly **Industrial, Inc.**®

MODEL G1163/G1163P PORTABLE DUST COLLECTOR

OWNER'S MANUAL

(For models manufactured since 9/12)



C US
247570

COPYRIGHT © DECEMBER, 2011 BY GRIZZLY INDUSTRIAL, INC. REVISED JULY, 2013 (BL)
**WARNING: NO PORTION OF THIS MANUAL MAY BE REPRODUCED IN ANY SHAPE
OR FORM WITHOUT THE WRITTEN APPROVAL OF GRIZZLY INDUSTRIAL, INC.**
#BL14597 PRINTED IN TAIWAN



WARNING!

This manual provides critical safety instructions on the proper setup, operation, maintenance, and service of this machine/tool. Save this document, refer to it often, and use it to instruct other operators.

Failure to read, understand and follow the instructions in this manual may result in fire or serious personal injury—including amputation, electrocution, or death.

The owner of this machine/tool is solely responsible for its safe use. This responsibility includes but is not limited to proper installation in a safe environment, personnel training and usage authorization, proper inspection and maintenance, manual availability and comprehension, application of safety devices, cutting/sanding/grinding tool integrity, and the usage of personal protective equipment.

The manufacturer will not be held liable for injury or property damage from negligence, improper training, machine modifications or misuse.



WARNING!

Some dust created by power sanding, sawing, grinding, drilling, and other construction activities contains chemicals known to the State of California to cause cancer, birth defects or other reproductive harm. Some examples of these chemicals are:

- **Lead from lead-based paints.**
- **Crystalline silica from bricks, cement and other masonry products.**
- **Arsenic and chromium from chemically-treated lumber.**

Your risk from these exposures varies, depending on how often you do this type of work. To reduce your exposure to these chemicals: Work in a well ventilated area, and work with approved safety equipment, such as those dust masks that are specially designed to filter out microscopic particles.

Table of Contents

INTRODUCTION	2	SECTION 4: OPERATIONS	18
Manual Accuracy	2	General	18
Contact Info.....	2	Machine Storage.....	18
Machine Description	2	SECTION 5: ACCESSORIES	19
Components & Terminology	3	SECTION 6: MAINTENANCE	20
Machine Data Sheet	4	Schedule	20
SECTION 1: SAFETY	6	Lubrication	20
Safety Instructions for Machinery	6	Bag Cleaning	20
Additional Safety for Dust Collectors	8	Impeller Tightening	20
SECTION 2: POWER SUPPLY	9	SECTION 7: SERVICE	21
Availability.....	9	Troubleshooting	21
Full-Load Current Rating	9	Motor & Electrical	21
Circuit Information	9	Dust Collector Operation	22
Circuit Requirements for 120V	9	SECTION 8: WIRING	23
Circuit Requirements for 240V	9	Wiring Safety Instructions	23
Grounding Requirements	10	Wiring Diagram	24
Extension Cords	10	SECTION 9: PARTS	25
Voltage Conversion to 240V.....	11	G1163 Main Breakdown	25
SECTION 3: SETUP	12	G1163P Main Breakdown.....	26
Needed for Setup.....	12	WARRANTY & RETURNS	29
Unpacking	12		
Inventory	13		
Site Considerations.....	13		
Placement Location	13		
Assembly	14		
Collection System	15		
Material Selection.....	15		
Duct Grounding	15		
Power Connection.....	16		
Connecting Power	16		
Disconnecting Power.....	16		
Test Run	17		

INTRODUCTION

Manual Accuracy

We are proud to offer this manual with your new machine! We've made every effort to be exact with the instructions, specifications, drawings, and photographs of the machine we used when writing this manual. However, sometimes we still make an occasional mistake.

Also, owing to our policy of continuous improvement, **your machine may not exactly match the manual**. If you find this to be the case, and the difference between the manual and machine leaves you in doubt, check our website for the latest manual update or call technical support for help.

Before calling, find the manufacture date of your machine by looking at the date stamped into the machine ID label (see below). This will help us determine if the manual version you received matches the manufacture date of your machine.

		MODEL GXXXX MACHINE NAME	
SPECIFICATIONS		WARNING!	
Motor:		Manufacture Date of Your Machine When using this machine: 1. Always wear eye protection, ear protection, and respirator. 2. Read and understand the instructions before starting. 3. Do not use the machine if you are tired, drowsy, or under the influence of drugs or alcohol. 4. Make sure the motor has stopped and disconnect power before adjustments, maintenance, or service. 5. DO NOT expose to rain or dampness. 6. DO NOT modify this machine in any way. 7. DO NOT remove safety guards. 8. Never leave machine running unattended. 9. DO NOT operate under the influence of drugs or alcohol. 10. Maintain machine carefully to prevent accidents.	
Specification:			
Specification:			
Specification:			
Weight:			
<input type="text"/>	Date		
<input type="text"/>	Serial Number		
Manufactured for Grizzly in Taiwan			

For your convenience, we post all available manuals and manual updates for free on our website at www.grizzly.com. Any updates to your model of machine will be reflected in these documents as soon as they are complete.

Contact Info

We stand behind our machines. If you have any questions or need help, use the information below to contact us. Before contacting, please get the serial number and manufacture date of your machine. This will help us help you faster.

Grizzly Technical Support
1203 Lycoming Mall Circle
Muncy, PA 17756
Phone: (570) 546-9663
Email: techsupport@grizzly.com

We want your feedback on this manual. What did you like about it? Where could it be improved? Please take a few minutes to give us feedback.

Grizzly Documentation Manager
P.O. Box 2069
Bellingham, WA 98227-2069
Email: manuals@grizzly.com

Machine Description

The Model G1163/G1163P is a point-of-use dust collector, which is designed to capture dust and wood chips from one woodworking machine at a time, such as a table saw, jointer, or planer. The air drawn in by the dust collector is filtered through a cloth collection bag that can be removed and emptied when full.

A wide variety of accessories for setting up a stationary or mobile dust collection system are available through Grizzly.

The only difference between the G1163 and G1163P is the paint color.



Components & Terminology

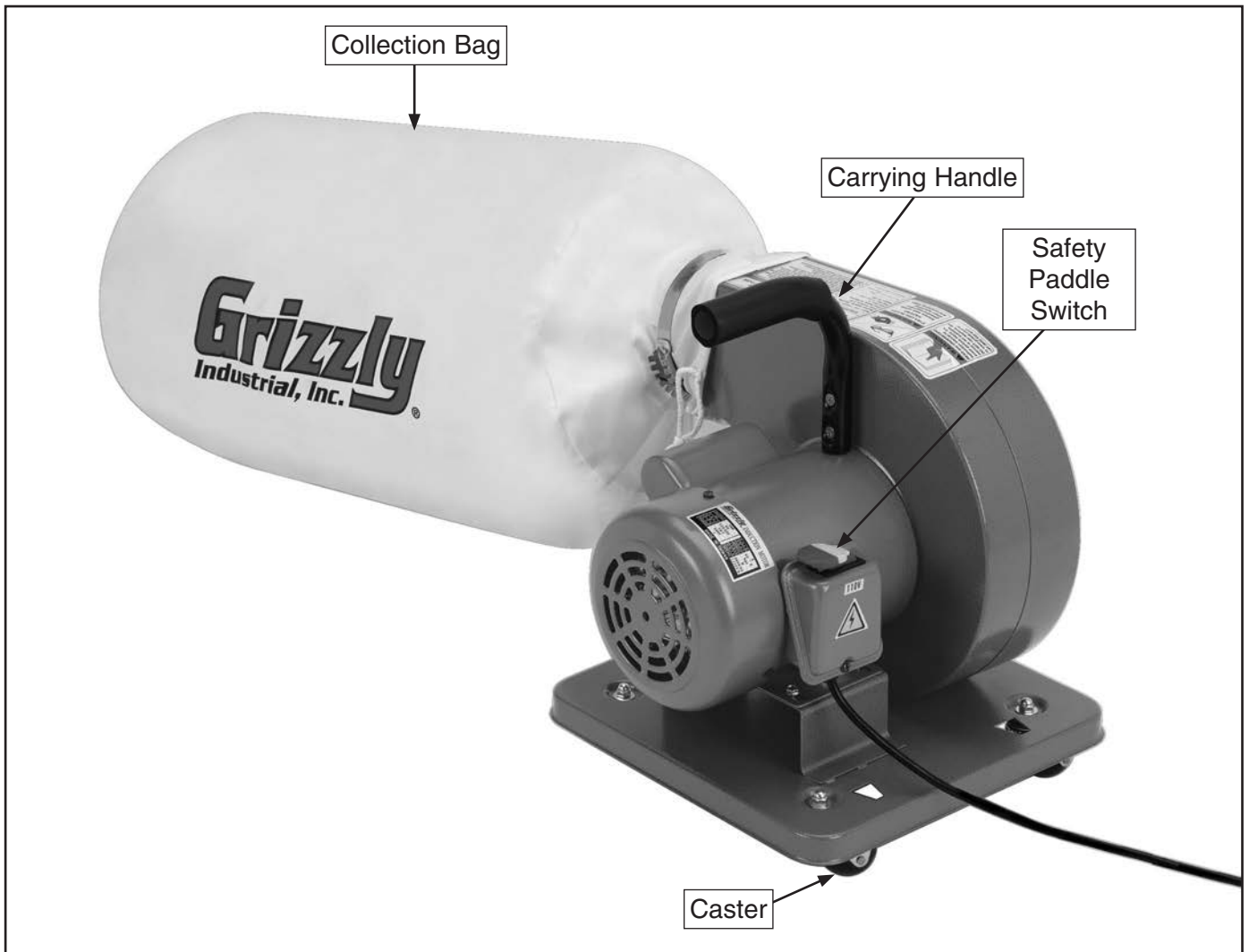

Figure 1. Model G1163 features shown.

<p>An illustration showing a hand pointing to a page in a manual. The manual is open, and the hand is pointing to a specific section of text. The text on the page is illegible but appears to be a list of instructions or safety warnings.</p>	<p>! WARNING</p> <p>To reduce the risk of serious injury when using this machine, read and understand this entire manual before beginning any operations.</p>
--	--





MACHINE DATA SHEET

Customer Service #: (570) 546-9663 · To Order Call: (800) 523-4777 · Fax #: (800) 438-5901

MODEL G1163/G1163P DUST COLLECTOR

Product Dimensions:

Weight..... 45 lbs.
 Width (side-to-side) x Depth (front-to-back) x Height..... 44 x 18 x 19-1/2 in.
 Footprint (Length x Width)..... 14 x 14 in.

Shipping Dimensions:

Type..... Cardboard
 Content..... Machine
 Weight..... 51 lbs.
 Length x Width x Height..... 18 x 19 x 16 in.

Electrical:

Power Requirement..... 120V/240V, Single-Phase, 60 Hz
 Prewired Voltage..... 120V
 Full-Load Current Rating..... 7A at 120V, 3.5A at 240V
 Minimum Circuit Size..... 15A at 120V, 15A at 240V
 Switch..... Safety Paddle Switch
 Switch Voltage..... 120V
 Cord Length..... 10 ft.
 Cord Gauge..... 16 AWG
 Plug Included..... Yes
 Included Plug Type..... NEMA 5-15 for 120V
 Recommended Plug/Outlet Type..... NEMA 6-15 for 240V

Motors:

Main

Type..... TEFC Capacitor Start Induction
 Horsepower..... 1 HP
 Voltage..... 120V/240V
 Prewired..... 120V
 Phase..... Single
 Amps..... 7A at 120V, 3.5A at 240V
 Speed..... 3450 RPM
 Cycle..... 60 Hz
 Number of Speeds..... 1
 Power Transfer Direct Drive
 Bearings..... Shielded and Permanently Lubricated

Main Specifications:

Operation

Air Suction Capacity..... 537 CFM
 Maximum Static Pressure..... 7.2 in.
 Main Inlet Size..... 4 in.
 Manifold Included..... No
 Machine Collection Capacity At One Time..... 1
 Maximum Material Collection Capacity..... 1.5 cu. ft.
 Upper Bag Filtration..... 30 Microns



Bag Information

Upper Bag Capacity..... 2 cu. ft.
No of Lower Bags..... 1
Upper Bags Total Area..... 2 cu. ft.
Upper Bag Diameter..... 13-1/2 in.
Upper Bag Length..... 24 in.

Impeller Information

Impeller Type..... Radial Fin
Impeller Size..... 10 in.
Impeller Blade Thickness..... 3/32 in.

Construction

Upper Bag..... Fabric
Base..... Fabricated Sheet Metal with Casters
Frame..... Formed Steel
Caster..... Plastic
Impeller..... Cast Aluminum
Paint..... Powder Coated

Other

Height With Bags Inflated..... 19-1/2 in.

Other Specifications:

ISO Factory ISO 9001
Country Of Origin Taiwan
Warranty 1 Year
Serial Number Location Machine ID Label on Collector
Awards Wood Magazine Top Value 1997

Features:

Includes Steel Base with Casters



SECTION 1: SAFETY

For Your Own Safety, Read Instruction Manual Before Operating This Machine

The purpose of safety symbols is to attract your attention to possible hazardous conditions. This manual uses a series of symbols and signal words intended to convey the level of importance of the safety messages. The progression of symbols is described below. Remember that safety messages by themselves do not eliminate danger and are not a substitute for proper accident prevention measures. Always use common sense and good judgment.

 **DANGER** Indicates an imminently hazardous situation which, if not avoided, **WILL** result in death or serious injury.

 **WARNING** Indicates a potentially hazardous situation which, if not avoided, **COULD** result in death or serious injury.

 **CAUTION** Indicates a potentially hazardous situation which, if not avoided, **MAY** result in minor or moderate injury. It may also be used to alert against unsafe practices.

NOTICE This symbol is used to alert the user to useful information about proper operation of the machine.

Safety Instructions for Machinery

WARNING

OWNER'S MANUAL. Read and understand this owner's manual **BEFORE** using machine.

TRAINED OPERATORS ONLY. Untrained operators have a higher risk of being hurt or killed. Only allow trained/supervised people to use this machine. When machine is not being used, disconnect power, remove switch keys, or lock-out machine to prevent unauthorized use—especially around children. Make workshop kid proof!

DANGEROUS ENVIRONMENTS. Do not use machinery in areas that are wet, cluttered, or have poor lighting. Operating machinery in these areas greatly increases the risk of accidents and injury.

MENTAL ALERTNESS REQUIRED. Full mental alertness is required for safe operation of machinery. Never operate under the influence of drugs or alcohol, when tired, or when distracted.

ELECTRICAL EQUIPMENT INJURY RISKS. You can be shocked, burned, or killed by touching live electrical components or improperly grounded machinery. To reduce this risk, only allow qualified service personnel to do electrical installation or repair work, and always disconnect power before accessing or exposing electrical equipment.

DISCONNECT POWER FIRST. Always disconnect machine from power supply **BEFORE** making adjustments, changing tooling, or servicing machine. This prevents an injury risk from unintended startup or contact with live electrical components.

EYE PROTECTION. Always wear ANSI-approved safety glasses or a face shield when operating or observing machinery to reduce the risk of eye injury or blindness from flying particles. Everyday eyeglasses are **NOT** approved safety glasses.



WARNING

WEARING PROPER APPAREL. Do not wear clothing, apparel or jewelry that can become entangled in moving parts. Always tie back or cover long hair. Wear non-slip footwear to avoid accidental slips, which could cause loss of workpiece control.

HAZARDOUS DUST. Dust created while using machinery may cause cancer, birth defects, or long-term respiratory damage. Be aware of dust hazards associated with each workpiece material, and always wear a NIOSH-approved respirator to reduce your risk.

HEARING PROTECTION. Always wear hearing protection when operating or observing loud machinery. Extended exposure to this noise without hearing protection can cause permanent hearing loss.

REMOVE ADJUSTING TOOLS. Tools left on machinery can become dangerous projectiles upon startup. Never leave chuck keys, wrenches, or any other tools on machine. Always verify removal before starting!

INTENDED USAGE. Only use machine for its intended purpose and never make modifications not approved by Grizzly. Modifying machine or using it differently than intended may result in malfunction or mechanical failure that can lead to serious personal injury or death!

AWKWARD POSITIONS. Keep proper footing and balance at all times when operating machine. Do not overreach! Avoid awkward hand positions that make workpiece control difficult or increase the risk of accidental injury.

CHILDREN & BYSTANDERS. Keep children and bystanders at a safe distance from the work area. Stop using machine if they become a distraction.

GUARDS & COVERS. Guards and covers reduce accidental contact with moving parts or flying debris. Make sure they are properly installed, undamaged, and working correctly.

FORCING MACHINERY. Do not force machine. It will do the job safer and better at the rate for which it was designed.

NEVER STAND ON MACHINE. Serious injury may occur if machine is tipped or if the cutting tool is unintentionally contacted.

STABLE MACHINE. Unexpected movement during operation greatly increases risk of injury or loss of control. Before starting, verify machine is stable and mobile base (if used) is locked.

USE RECOMMENDED ACCESSORIES. Consult this owner's manual or the manufacturer for recommended accessories. Using improper accessories will increase the risk of serious injury.

UNATTENDED OPERATION. To reduce the risk of accidental injury, turn machine **OFF** and ensure all moving parts completely stop before walking away. Never leave machine running while unattended.

MAINTAIN WITH CARE. Follow all maintenance instructions and lubrication schedules to keep machine in good working condition. A machine that is improperly maintained could malfunction, leading to serious personal injury or death.

CHECK DAMAGED PARTS. Regularly inspect machine for any condition that may affect safe operation. Immediately repair or replace damaged or mis-adjusted parts before operating machine.

MAINTAIN POWER CORDS. When disconnecting cord-connected machines from power, grab and pull the plug—NOT the cord. Pulling the cord may damage the wires inside. Do not handle cord/plug with wet hands. Avoid cord damage by keeping it away from heated surfaces, high traffic areas, harsh chemicals, and wet/damp locations.

EXPERIENCING DIFFICULTIES. If at any time you experience difficulties performing the intended operation, stop using the machine! Contact our Technical Support at (570) 546-9663.



Additional Safety for Dust Collectors

WARNING

INTENDED USE. This dust collector is only intended for collecting wood dust and chips from woodworking machines. DO NOT use this dust collector to collect metal, dirt, pebbles, drywall, asbestos, lead paint, silica, liquids, aerosols, or any flammable, combustible, or hazardous materials.

HAZARDOUS DUST. Dust created while using machinery may cause cancer, birth defects, or long-term respiratory damage. Be aware of dust hazards associated with each workpiece material, and always wear a NIOSH-approved respirator to reduce your risk.

DUST ALLERGIES. Dust from certain woods may cause an allergic reaction in people and animals. Make sure you know what type of wood dust you will be exposed to in case there is a possibility of an allergic reaction.

WEAR RESPIRATOR. Fine dust that is too small to be caught in the filter will be blown into the ambient air during operation. Always wear a NIOSH approved respirator during operation and for a short time after to reduce your risk of permanent respiratory damage.

EMPTYING DUST. When emptying dust from the collection container, wear a respirator and safety glasses. Empty dust away from ignition sources and into an approved container.

DISCONNECTING POWER SUPPLY. Turn the switch **OFF**, disconnect the dust collector from the power supply, and allow the impeller to come to a complete stop before leaving the machine unattended or doing any service, cleaning, maintenance, or adjustments.

REGULAR CLEANING. Regularly check/empty the collection bags or drum to avoid the buildup of fine dust that can increase the risk of fire. Make sure to regularly clean the surrounding area where the machine is operated—excessive dust buildup on overhead lights, heaters, electrical panels, or other heat sources will increase the risk of fire.

SUSPENDED DUST PARTICLES AND IGNITION SOURCES. DO NOT operate the dust collector in areas where explosion risks are high. Areas of high risk include, but are not limited to, areas near pilot lights, open flames, or other ignition sources.

FIRE SUPPRESSION. Only operate the dust collector in locations that contain a fire suppression system or have a fire extinguisher nearby.

IMPELLER HAZARDS. DO NOT place your hands or tools near the open inlet during operation for any reason. The powerful suction could easily cause accidental contact with the impeller which will cause serious personal injury or damage to the machine. Always keep small animals and children away from open dust collection inlets.

AVOIDING SPARKS. DO NOT allow steel or rocks to strike the impeller—this may produce sparks. Sparks can smolder in wood dust for a long time before a fire is detected. If you accidentally cut into wood containing tramp metal (nails, staples, spikes, etc.), immediately turn **OFF** the dust collector, disconnect it from power, and wait for the impeller to stop—then empty the collection container into an approved airtight metal container.

OPERATING LOCATION. To reduce respiratory exposure to fine dust, locate permanently installed dust collectors away from the working area, or in another room that is equipped with a smoke detector. DO NOT operate the dust collector in rainy or wet locations—exposure to water may create a shock hazard or decrease the life of the machine.

STATIC ELECTRICITY. Plastic dust lines generate high amounts of static electricity as dust chips pass through them. Although rare, sparks caused by static electricity can cause explosions or fire. To reduce this risk, make sure all dust lines are thoroughly grounded by using a grounding wire.



SECTION 2: POWER SUPPLY

Availability

Before installing the machine, consider the availability and proximity of the required power supply circuit. If an existing circuit does not meet the requirements for this machine, a new circuit must be installed. To minimize the risk of electrocution, fire, or equipment damage, installation work and electrical wiring must be done by an electrician or qualified service personnel in accordance with all applicable codes and standards.

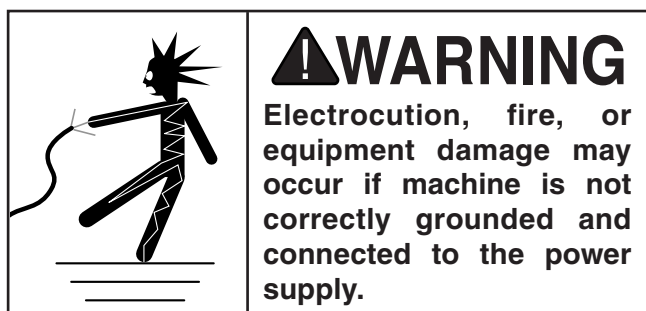

Full-Load Current Rating

The full-load current rating is the amperage a machine draws at 100% of the rated output power. On machines with multiple motors, this is the amperage drawn by the largest motor or sum of all motors and electrical devices that might operate at one time during normal operations.

Full-Load Current Rating at 120V 7 Amps

Full-Load Current Rating at 240V 3.5 Amps

The full-load current is not the maximum amount of amps that the machine will draw. If the machine is overloaded, it will draw additional amps beyond the full-load rating.

If the machine is overloaded for a sufficient length of time, damage, overheating, or fire may result—especially if connected to an undersized circuit. To reduce the risk of these hazards, avoid overloading the machine during operation and make sure it is connected to a power supply circuit that meets the requirements in the following section.

Circuit Information

A power supply circuit includes all electrical equipment between the breaker box or fuse panel in the building and the machine. The power supply circuit used for this machine must be sized to safely handle the full-load current drawn from the machine for an extended period of time. (If this machine is connected to a circuit protected by fuses, use a time delay fuse marked D.)

! CAUTION

For your own safety and protection of property, consult an electrician if you are unsure about wiring practices or electrical codes in your area.

Note: *The circuit requirements listed in this manual apply to a dedicated circuit—where only one machine will be running at a time. If this machine will be connected to a shared circuit where multiple machines will be running at the same time, consult a qualified electrician to ensure that the circuit is properly sized for safe operation.*

Circuit Requirements for 120V

This machine is prewired to operate on a 120V power supply circuit that has a verified ground and meets the following requirements:

Nominal Voltage 110V/120V
Cycle 60 Hz
Phase Single-Phase
Power Supply Circuit 15 Amps
Plug/Receptacle NEMA 5-15

Circuit Requirements for 240V

This machine can be converted to operate on a 240V power supply (refer to **Voltage Conversion** instructions) that has a verified ground and meets the following requirements:

Nominal Voltage 220V/240V
Cycle 60 Hz
Phase Single-Phase
Power Supply Circuit 15 Amps
Plug/Receptacle NEMA 6-15



Grounding Requirements

This machine **MUST** be grounded. In the event of certain malfunctions or breakdowns, grounding reduces the risk of electric shock by providing a path of least resistance for electric current.

For 120V operation: This machine is equipped with a power cord that has an equipment-grounding wire and a grounding plug (see following figure). The plug must only be inserted into a matching receptacle (outlet) that is properly installed and grounded in accordance with all local codes and ordinances.

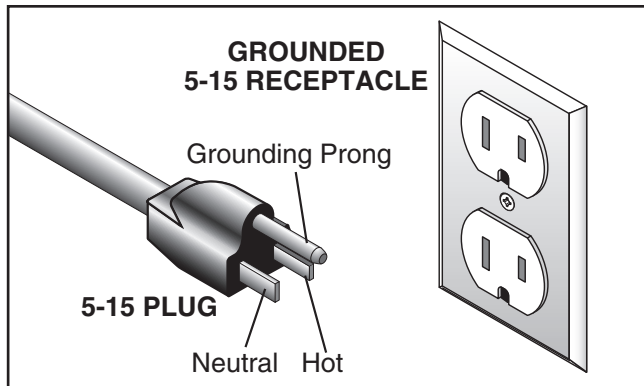

Figure 2. Typical 5-15 plug and receptacle.

⚠ CAUTION

SHOCK HAZARD!

Two-prong outlets do not meet the grounding requirements for this machine. Do not modify or use an adapter on the plug provided—if it will not fit the outlet, have a qualified electrician install the proper outlet with a verified ground.

For 240V operation: The plug specified under “Circuit Requirements for 240V” on the previous page has a grounding prong that must be attached to the equipment-grounding wire on the included power cord. The plug must only be inserted into a matching receptacle (see following figure) that is properly installed and grounded in accordance with all local codes and ordinances.

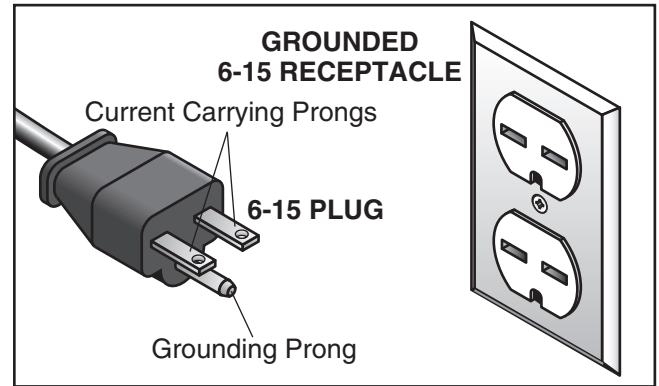

Figure 3. Typical 6-15 plug and receptacle.

Improper connection of the equipment-grounding wire can result in a risk of electric shock. The wire with green insulation (with or without yellow stripes) is the equipment-grounding wire. If repair or replacement of the power cord or plug is necessary, do not connect the equipment-grounding wire to a live (current carrying) terminal.

Check with a qualified electrician or service personnel if you do not understand these grounding requirements, or if you are in doubt about whether the tool is properly grounded. If you ever notice that a cord or plug is damaged or worn, disconnect it from power, and immediately replace it with a new one.

Extension Cords

We do not recommend using an extension cord with this machine. If you must use an extension cord, only use it if absolutely necessary and only on a temporary basis.

Extension cords cause voltage drop, which may damage electrical components and shorten motor life. Voltage drop increases as the extension cord size gets longer and the gauge size gets smaller (higher gauge numbers indicate smaller sizes).

Any extension cord used with this machine must contain a ground wire, match the required plug and receptacle, and meet the following requirements:

- Minimum Gauge Size (120V)16 AWG**
- Minimum Gauge Size (240V)16 AWG**
- Maximum Length (Shorter is Better).....50 ft.**



Voltage Conversion to 240V

The voltage conversion **MUST** be performed by an electrician or qualified service personnel. To perform the voltage conversion, install the correct plug and rewire the motor to the new voltage, according to the provided wiring diagram. *If the diagram included on the motor conflicts with the one on **Page 24** in this manual, the motor may have changed since the manual was printed. Use the diagram provided inside the motor wiring junction box.*

Items Needed

Items Needed	Qty
• Phillips Head Screwdriver #2	1
• Electrical Tape.....	As Needed
• Wire Nut (16 AWG x 3).....	1
• 6-15 Plug	1

To convert the Model G1163/G1163P to 240V:

1. DISCONNECT MACHINE FROM POWER!
2. Open the motor junction box, then loosen the wire nuts indicated in **Figure 4**.

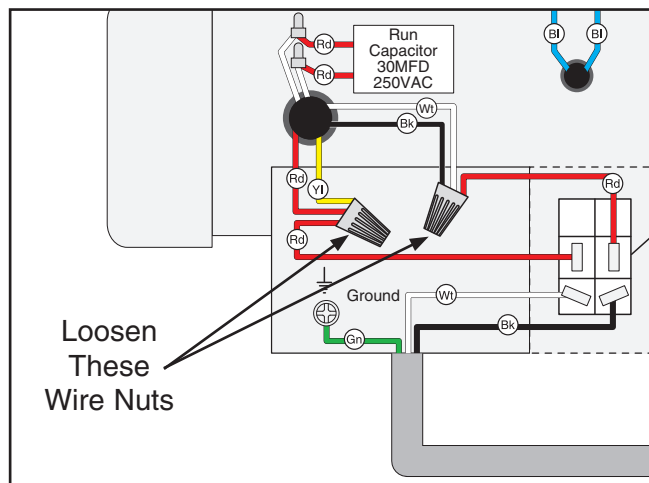

Figure 4. Location of wire nuts to be loosened on when converting voltage.

3. Use wire nuts to connect the wires as indicated in **Figure 5**. Twist all three wire nuts onto their respective wires and wrap them with electrical tape so they will not come loose.

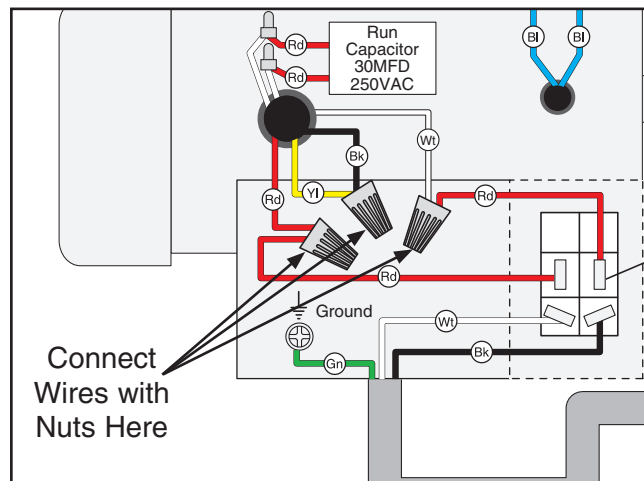
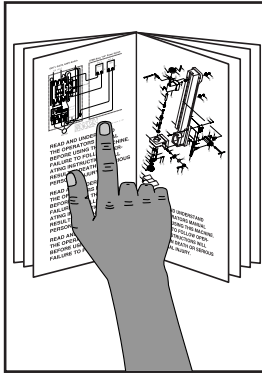

Figure 5. Model G1163/G1163P rewired to 240V.

4. Close and secure the motor junction box.
5. Remove the 5-15 plug from the power cord and install a 6-15 plug according to the manufacturer's instructions.



SECTION 3: SETUP



!WARNING
This machine presents serious injury hazards to untrained users. Read through this entire manual to become familiar with the controls and operations before starting the machine!



!WARNING
Wear safety glasses during the entire setup process!

Needed for Setup

The following are needed to complete the setup process, but are not included with your machine.

Description	Qty
• Safety Glasses (for each person).....	1
• Standard Screwdriver #2.....	1

Unpacking

Your machine was carefully packaged for safe transportation. Remove the packaging materials from around your machine and inspect it. If you discover any damage, *please call us immediately at (570) 546-9663 for advice.*

Save the containers and all packing materials for possible inspection by the carrier or its agent. *Otherwise, filing a freight claim can be difficult.*

When you are completely satisfied with the condition of your shipment, inventory the contents.



!WARNING
SUFFOCATION HAZARD!
Keep children and pets away from plastic bags or packing materials shipped with this machine. Discard immediately.



Inventory

The following is a list of items shipped with your machine. Before beginning setup, lay these items out and inventory them.

If any non-proprietary parts are missing (e.g. a nut or a washer), we will gladly replace them; or for the sake of expediency, replacements can be obtained at your local hardware store.

Box 1:	Qty
A. Collector Body and Fan/Motor Assembly (Not Shown).....	1
B. Base Plate	1
C. Casters	4
D. Collection Bag	1
E. Bag Clamp.....	1
F. Foam Strip 4 x 20 x 430mm.....	1

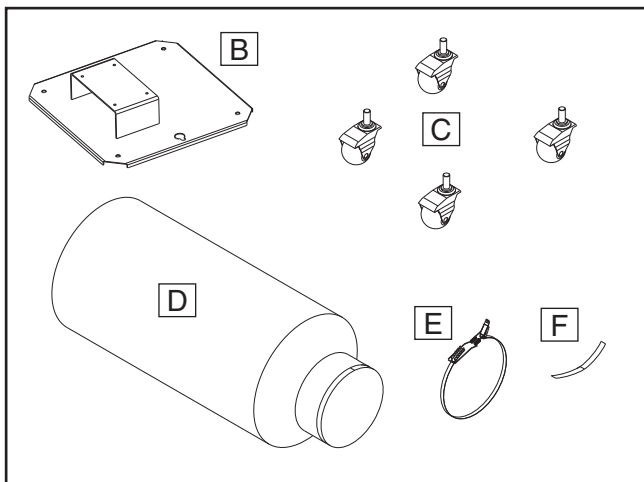

Figure 6. Model G1163/G1163P inventory.

Hardware and Tools (and Location)

- Acorn Nuts $\frac{5}{16}$ "-18 (Casters)..... 4
- Flat Washers $\frac{5}{16}$ " (Casters)..... 4
- Flange Bolts $\frac{1}{4}$ "-20 X $\frac{1}{2}$ " (Fan/Motor) 4
- Open-End Wrench 10 x 12mm..... 1

NOTICE

If you cannot find an item on this list, carefully check around/inside the machine and packaging materials. Often, these items get lost in packaging materials while unpacking or they are pre-installed at the factory.

Site Considerations

Placement Location

Consider existing and anticipated needs, size of material to be processed through each machine, and space for auxiliary stands, work tables or other machinery when establishing a location for your new machine. See **Figure 7** for the minimum working clearances.

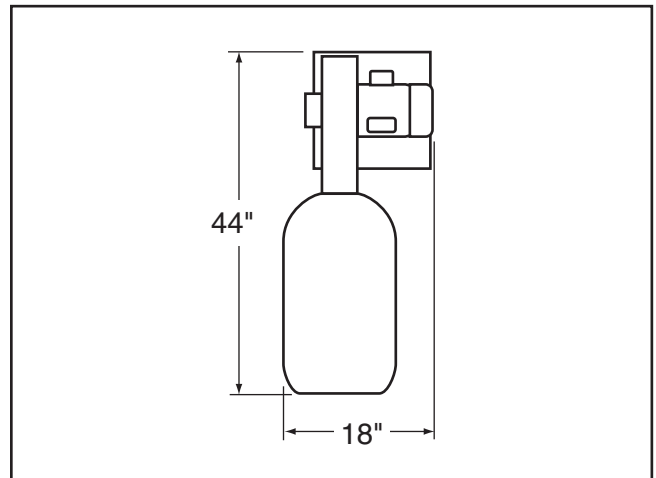

Figure 7. Minimum working clearances.

	<p>CAUTION</p> <p>Children and visitors may be seriously injured if unsupervised around this machine. Lock entrances to the shop or disable start switch or power connection to prevent unsupervised use.</p>
--	--



Assembly

To assemble your machine:

1. Position the base plate upside down and mount the casters using the (4) $\frac{5}{16}$ " flat washers and acorn nuts, as shown in **Figure 8**.

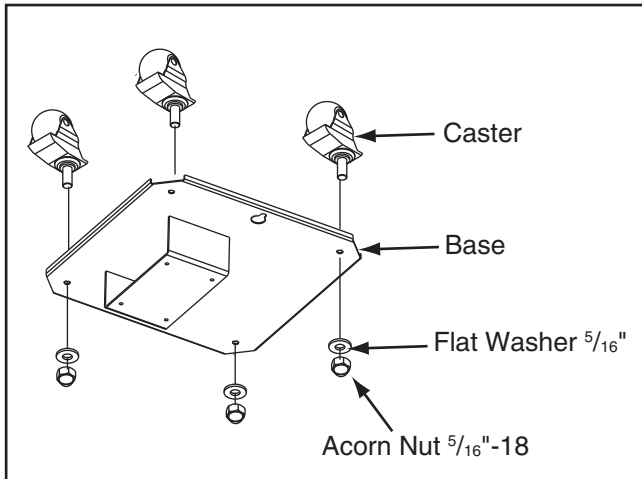

Figure 8. Mounting the casters.

2. Position the collector body and fan/motor assembly on the base, then secure it with the flange bolts, as shown in **Figure 9**.

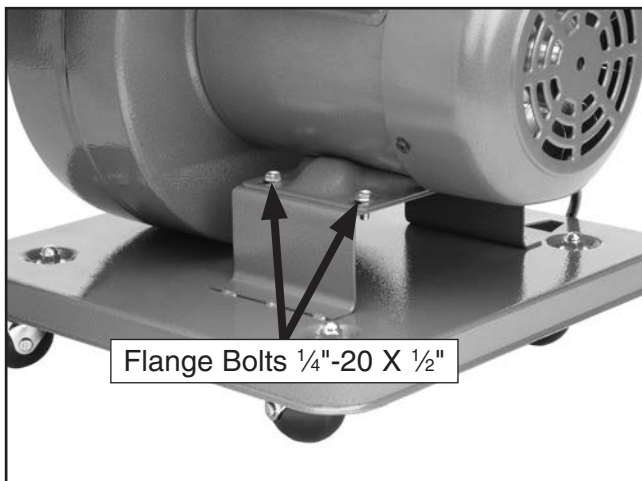

Figure 9. Mounting the collector body assembly to the base.

3. Wrap the foam strip around the outfeed port of the collector body, as shown in **Figure 10**. Cut to fit if necessary.

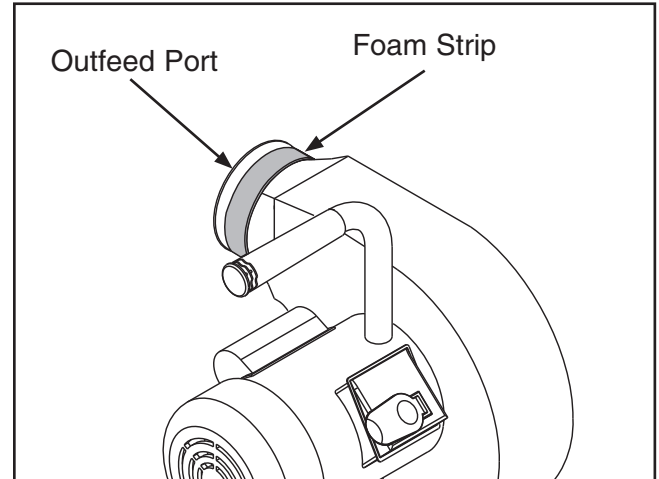

Figure 10. Location to install foam strip.

4. Fit the collection bag over the outfeed port, and secure it with the provided clamp, as shown in **Figure 11**.

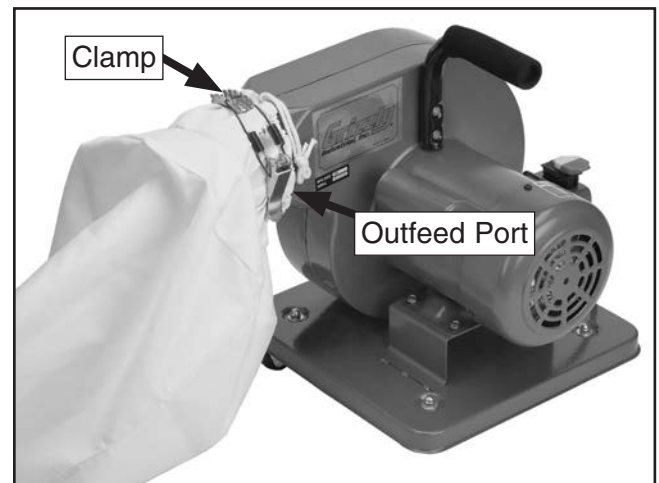

Figure 11. Attaching the collection bag.



Collection System

Material Selection

You have many choices regarding dust collection ducting, but flexible hose is the most common for this size of machine. However, be aware that there is a fire or explosion hazard if plastic duct material is used for dust collection without being grounded against static electrical charge build-up.

Flexible rubber hose, polyethylene, plastic flex-hose and other flexible ribbed hose is generally used for short runs. There are many different types of flex hose on the market today. These are manufactured from materials such as polyethylene, PVC, cloth hose dipped in rubber and even metal, including steel and aluminum.

If using flex-hose, you should choose one of the many types that are designed specifically for the movement of solid particles, i.e. dust, grains and plastics. However, the cost of specifically designed flexible duct can vary greatly. Grizzly offers polyethylene and steel flex hose.

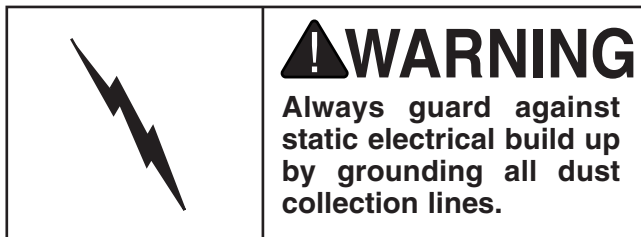

Duct Grounding

Plastic flex-hose is an insulator, and dust particles moving against the walls of the hose creates a static electrical build up. This charge will build until it discharges to a ground. If a grounding medium is not available to prevent static electrical build up, the electrical charge will arc to the nearest grounded source. This electrical discharge may cause an explosion and subsequent fire inside the system.

To protect against static electrical build up inside a non-conducting duct, a bare copper wire should be placed inside the duct along its length and grounded to the dust collector. You must also confirm that the dust collector is continuously grounded through the electrical circuit to the electric service panel.

Be sure that you extend the bare copper wire down all branches of the system. Do not forget to connect the wires to each other with wire nuts when two branches meet at a “Y” or “T” connection.

Ensure that the entire system is grounded. If using plastic blast gates to direct air flow, the grounding wire must be jumped (**Figure 12**) around the blast gate without interruption to the grounding system.

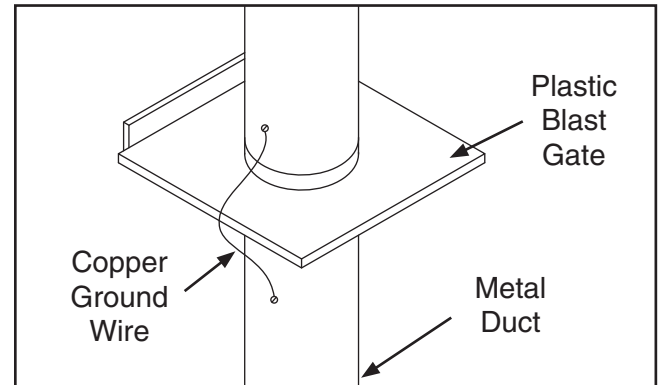

Figure 12. Ground jumper wire when using plastic blast gates or elbows and metal duct.

We also recommend wrapping the outside of all plastic ducts with bare copper wire to ground the outside of the system against static electrical build up. Wire connections at Y’s and T’s should be made with wire nuts.

Attach the bare ground wire to each stationary woodworking machine and attach the dust collector frame with a ground screw, as shown in **Figure 13**. Ensure that each machine is continuously grounded to the grounding terminal in your electric service panel.

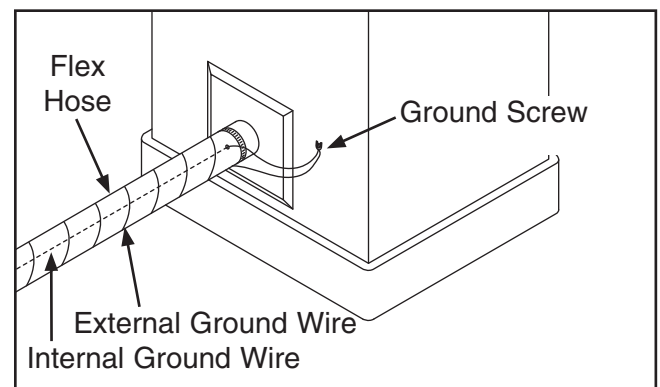

Figure 13. Flex-hose grounded to machine.



Power Connection

After you have completed all previous setup instructions and circuit requirements, the machine is ready to be connected to the power supply.

To prevent accidental damage to the power cord, make sure it is kept away from potential damage sources at all times—whether connected or not. Potential damage sources include high traffic areas, sharp objects, heat sources, harsh chemicals, water, damp areas, etc.

To avoid unexpected startups or property damage, use the following steps whenever connecting or disconnecting the machine.

Connecting Power

1. Turn the machine power switch **OFF**.
2. Insert the power cord plug into a matching power supply receptacle. The machine is now connected to the power source.

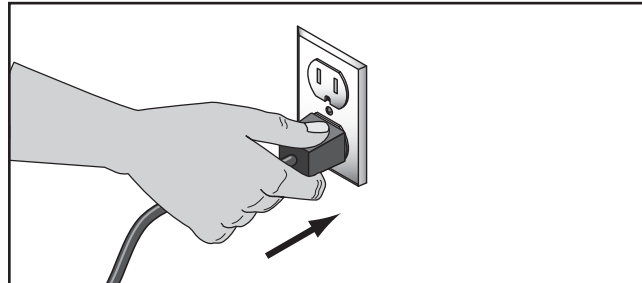

Figure 14. Connecting power.

Disconnecting Power

1. Turn the machine power switch **OFF**.
2. Grasp the molded plug and pull it completely out of the receptacle. Do not pull by the cord as this may damage the wires inside.

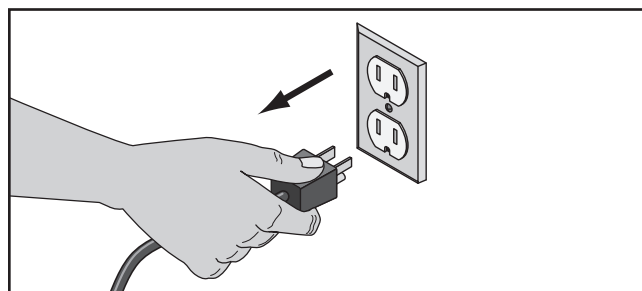

Figure 15. Disconnecting power.



Test Run

Once the assembly is complete, test run your machine to make sure it runs properly and is ready for regular operation.

The test run consists of verifying the following:
1) The motor powers up and runs correctly, and
2) the safety disabling mechanism on the switch works correctly.

If, during the test run, you cannot easily locate the source of an unusual noise or vibration, stop using the machine immediately, then review **Troubleshooting** on **Page 21**.

If you still cannot remedy a problem, contact our Tech Support at (570) 546-9663 for assistance.

To test run the machine:

1. Make sure you have read the safety instructions at the beginning of the manual and that the machine is setup properly.
2. Make sure all tools and objects used during setup are cleared away from the machine.
3. Verify that the machine is operating correctly by turning the machine **ON**.

—When operating correctly, the machine runs smoothly with little or no vibration or rubbing noises.

—Investigate and correct strange or unusual noises or vibrations before operating the machine further. Always disconnect the machine from power when investigating or correcting potential problems.

4. Turn the machine **OFF**.
5. Remove the switch disabling key, as shown in **Figure 16**.

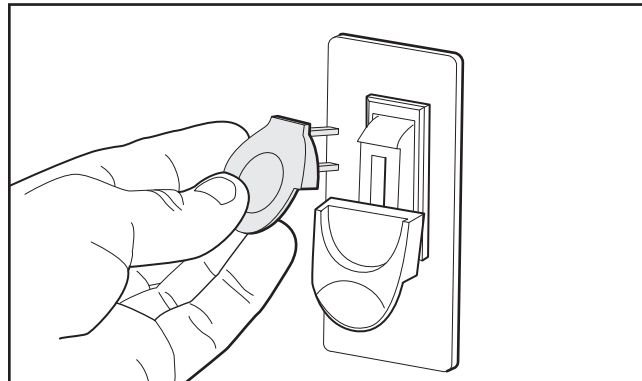
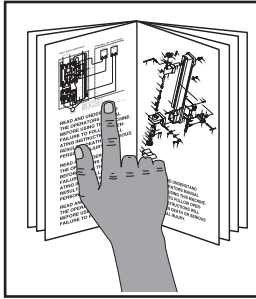

Figure 16. Removing switch disabling key from paddle switch.

6. Try to start the machine with the paddle switch.
 - If the machine does not start, the switch disabling feature is working as designed.
 - If the machine does start, immediately stop the machine. The switch disabling feature is not working correctly. This safety feature must work properly before proceeding with regular operations. Call Tech Support for help.



SECTION 4: OPERATIONS



!WARNING

To reduce the risk of serious injury when using this machine, read and understand this entire manual before beginning any operations.

!WARNING

Damage to your eyes and lungs could result from using this machine without proper protective gear. Always wear safety glasses and a respirator when operating this machine.

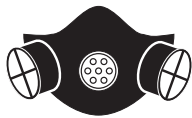

!WARNING

Do NOT put hands or small objects near inlet openings during operation. Objects sucked into the inlet will hit the impeller blade. Failure to heed this warning could result in personal injury or property damage.

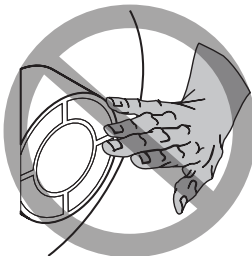

NOTICE

If you have never used this type of machine or equipment before, WE STRONGLY RECOMMEND that you read books, trade magazines, or get formal training before beginning any projects. Regardless of the content in this section, Grizzly Industrial will not be held liable for accidents caused by lack of training.

General

Operating the Model G1163/G1163P is simple and straightforward. Move the dust collector near the machine to a location where it will not interfere with the workpiece being processed, connect the duct, connect the ducting ground, and you are ready to begin.

If you decide to use the dust collector as a stationary unit, keep in mind that it is intended for single machine use and is not designed to draw dust through long runs and multiple ports simultaneously. We do not recommend using ducting longer than 10 feet. Otherwise, dust collection efficiency will be greatly reduced.

Machine Storage

When the dust collector is not in use, unplug the power cord from the power source. Place the cord away from potential damage sources, such as high traffic areas, sharp objects, heat sources, harsh chemicals, water, damp areas, etc.



SECTION 5: ACCESSORIES

!WARNING

Installing unapproved accessories may cause machine to malfunction, resulting in serious personal injury or machine damage. To reduce this risk, only install accessories recommended for this machine by Grizzly.

NOTICE

Refer to our website or latest catalog for additional recommended accessories.

- D4203—Clear Flexible Hose 2½" x 10'
- D4206—Clear Flexible Hose 4" x 10'
- D4212—Black Flexible Hose 2½" x 10'
- D4216—Black Flexible Hose 4" x 10'
- W1314—Wire Hose Clamp 2½"
- W1317—Wire Hose Clamp 4"
- W1044—Dust Collection Adapter 2½" x 4"
- W1007—Plastic Blast Gate 4"
- W1053—Grounding Kit
- W2046—Shop Vacuum Adapter 2½" x 2½"

We've hand picked a selection of dust collection components commonly needed to connect the Model G1163/G1163P to basic machinery.



Figure 17. Dust collection accessories.

H4340—3.0 Micron Bag

For improved filtering capabilities, upgrade to a 3.0 micron filter bag.



Figure 18. Fine filter bags.

W1054—Dust Collection Kit #1

Designed for a one machine hook-up, kit #1 comes complete with installation instructions and an accessories list for expanding your dust collection system in the future.

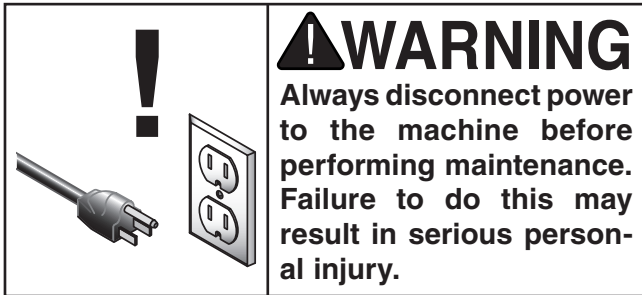

Figure 19. Model W1054 Dust Collection Kit #1.

order online at www.grizzly.com or call 1-800-523-4777



SECTION 6: MAINTENANCE



Schedule

For optimum performance from your machine, follow this maintenance schedule and refer to any specific instructions given in this section.

Daily Check:

- Loose mounting bolts.
- Worn switch.
- Worn or damaged wires.
- Full collection bag.
- Any other unsafe condition.

Lubrication

Since all bearings are shielded and permanently lubricated, simply leave them alone until they need to be replaced. Do not lubricate them.

Bag Cleaning

Always empty the collection bag on a regular basis. Emptying the collection bag allows the machine to operate at a much higher level of efficiency. Always wear the appropriate respirator or dust mask and safety glasses when emptying the collection bag. Small dust particles can escape the bag during emptying, causing them to become airborne and easily inhaled. This microscopic airborne dust is extremely unhealthy to breathe and can cause serious health problems.

Impeller Tightening

DISCONNECT DUST COLLECTOR FROM POWER BEFORE ATTEMPTING THIS PROCEDURE!

Periodically check the impeller to make sure it is tight on the motor shaft. Any unusual vibration or noise may be an indication the impeller has loosened. A set screw and a left-hand cap screw secure the impeller to the shaft. These can be accessed through the inlet cover, as shown in **Figure 20**. Tighten the fasteners as needed.

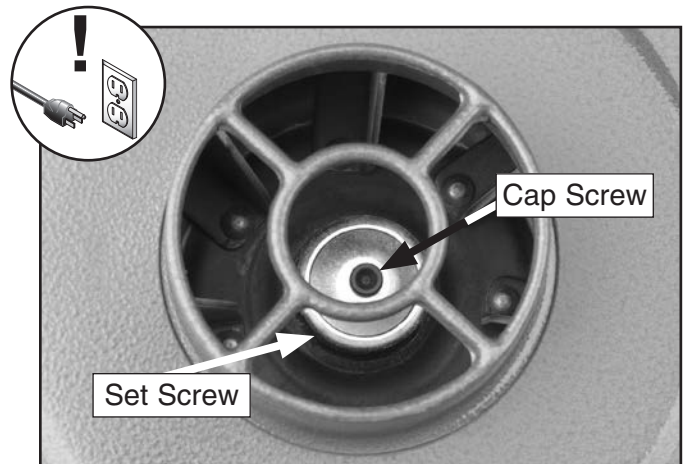
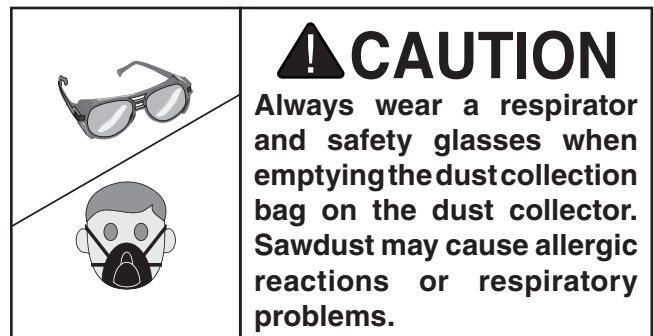

Figure 20. Impeller screw locations.



SECTION 7: SERVICE

Review the troubleshooting and procedures in this section if a problem develops with your machine. If you need replacement parts or additional help with a procedure, call our Technical Support at (570) 546-9663.

Note: Please gather the serial number and manufacture date of your machine before calling.

Troubleshooting

Motor & Electrical



Symptom	Possible Cause	Possible Solution
Machine does not start or a breaker trips.	<ol style="list-style-type: none"> 1. Switch disabling key removed. 2. Wall fuse/circuit breaker is blown/tripped. 3. Power supply switched OFF or is at fault. 4. Wiring is open/has high resistance. 5. Motor ON/OFF switch is at fault. 6. Motor is at fault. 	<ol style="list-style-type: none"> 1. Install disabling key. 2. Ensure circuit size is suitable for this machine; replace weak breaker. 3. Ensure power supply is switched ON; ensure power supply has the correct voltage. 4. Check for broken wires or disconnected/corroded connections, and repair/replace as necessary. 5. Replace faulty ON/OFF switch. 6. Test/repair/replace.
Machine has vibration or noisy operation.	<ol style="list-style-type: none"> 1. Motor or component is loose. 2. Motor mount loose/broken. 3. Machine is incorrectly mounted or sits unevenly. 4. Motor fan is rubbing on fan cover. 5. Motor bearings are at fault. 	<ol style="list-style-type: none"> 1. Inspect/replace stripped or damaged bolts/nuts, and re-tighten with thread locking fluid. 2. Tighten/replace. 3. Tighten/replace mounting hardware; chock casters if mobile. 4. Replace dented fan cover; replace loose/damaged fan. 5. Test by rotating shaft; rotational grinding/loose shaft requires bearing replacement.



Dust Collector Operation

Symptom	Possible Cause	Possible Solution
Dust collector does not adequately collect dust or chips; poor performance.	<ol style="list-style-type: none"> 1. Dust collection bag is full. 2. Restriction in duct line. 3. Dust collector is too far away, or there are too many sharp bends in the ducting. 4. Lumber is wet and dust is not flowing through ducting smoothly. 5. Leaks in ducting or too many open ports. 6. Ducting or machine dust ports are incorrectly sized. 7. The machine dust collection design is inadequate. 8. The dust collector is too small for the task or machine. 	<ol style="list-style-type: none"> 1. Empty collection bag. 2. Remove restriction in the duct line. A plumber snake may be necessary. 3. Relocate the dust collector closer to the point of suction, and rework ducting without sharp bends. Refer to Collection System, beginning on Page 15. 4. Process lumber with less than 20% moisture content. 5. Rework the ducting to eliminate all leaks. Close dust ports for lines not being used. 6. Re-install correctly sized ducts and fittings. Refer to Collection System beginning on Page 15 for more solutions. 7. Use a dust collection nozzle on a stand. 8. Use a larger dust collector.
Sawdust being blown into the air from the dust collector.	<ol style="list-style-type: none"> 1. Duct clamps or dust collection bag is not properly clamped and secured. 2. Bag clamp is loose or damaged. 	<ol style="list-style-type: none"> 1. Re-secure ducts and dust collection bag, making sure duct and bag clamps are tight and completely over the ducts and bag. 2. Re-tighten bag clamp.

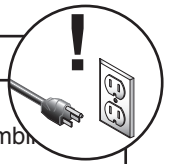

SECTION 8: WIRING

These pages are current at the time of printing. However, in the spirit of improvement, we may make changes to the electrical systems of future machines. Compare the manufacture date of your machine to the one stated in this manual, and study this section carefully.

If there are differences between your machine and what is shown in this section, call Technical Support at (570) 546-9663 for assistance BEFORE making any changes to the wiring on your machine. An updated wiring diagram may be available. **Note:** *Please gather the serial number and manufacture date of your machine before calling. This information can be found on the main machine label.*

WARNING

Wiring Safety Instructions

SHOCK HAZARD. Working on wiring that is connected to a power source is extremely dangerous. Touching electrified parts will result in personal injury including but not limited to severe burns, electrocution, or death. Disconnect the power from the machine before servicing electrical components!

MODIFICATIONS. Modifying the wiring beyond what is shown in the diagram may lead to unpredictable results, including serious injury or fire. This includes the installation of unapproved after-market parts.

WIRE CONNECTIONS. All connections must be tight to prevent wires from loosening during machine operation. Double-check all wires disconnected or connected during any wiring task to ensure tight connections.

CIRCUIT REQUIREMENTS. You MUST follow the requirements at the beginning of this manual when connecting your machine to a power source.

WIRE/COMPONENT DAMAGE. Damaged wires or components increase the risk of serious personal injury, fire, or machine damage. If you notice that any wires or components are damaged while performing a wiring task, replace those wires or components.

MOTOR WIRING. The motor wiring shown in these diagrams is current at the time of printing but may not match your machine. If you find this to be the case, use the wiring diagram inside the motor junction box.















CAPACITORS/INVERTERS. Some capacitors and power inverters store an electrical charge for up to 10 minutes after being disconnected from the power source. To reduce the risk of being shocked, wait at least this long before working on capacitors.

EXPERIENCING DIFFICULTIES. If you are experiencing difficulties understanding the information included in this section, contact our Technical Support at (570) 546-9663.

NOTICE

The photos and diagrams included in this section are best viewed in color. You can view these pages in color at www.grizzly.com.

COLOR KEY

BLACK		BLUE		YELLOW		LIGHT BLUE	
WHITE		BROWN		YELLOW GREEN		BLUE WHITE	
GREEN		GRAY		PURPLE		TURQUOISE	
RED		ORANGE		PINK			



Wiring Diagram



Figure 23. Start capacitor.

120 Volt Motor

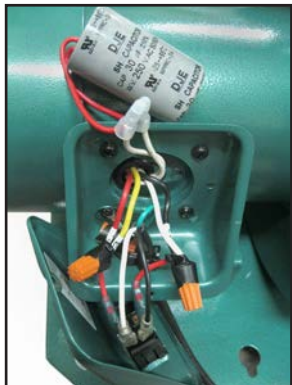
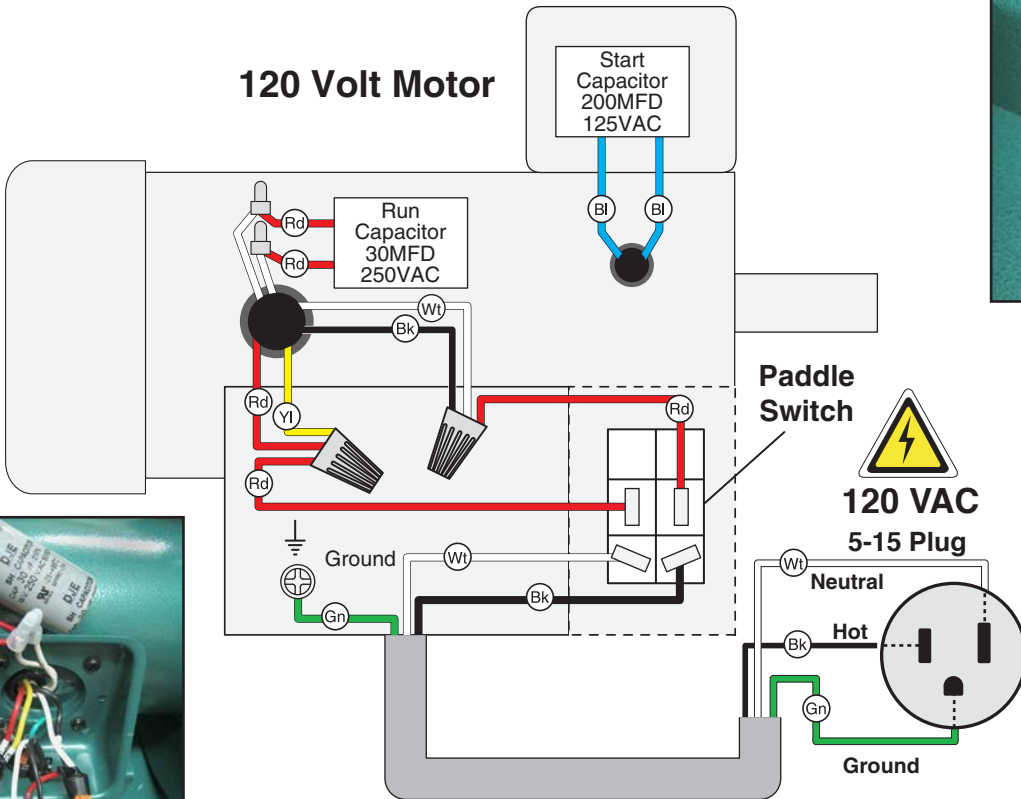

Figure 21. 120V junction box.

240 Volt Motor

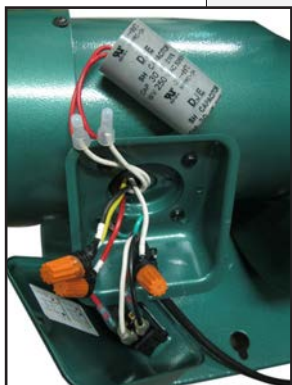
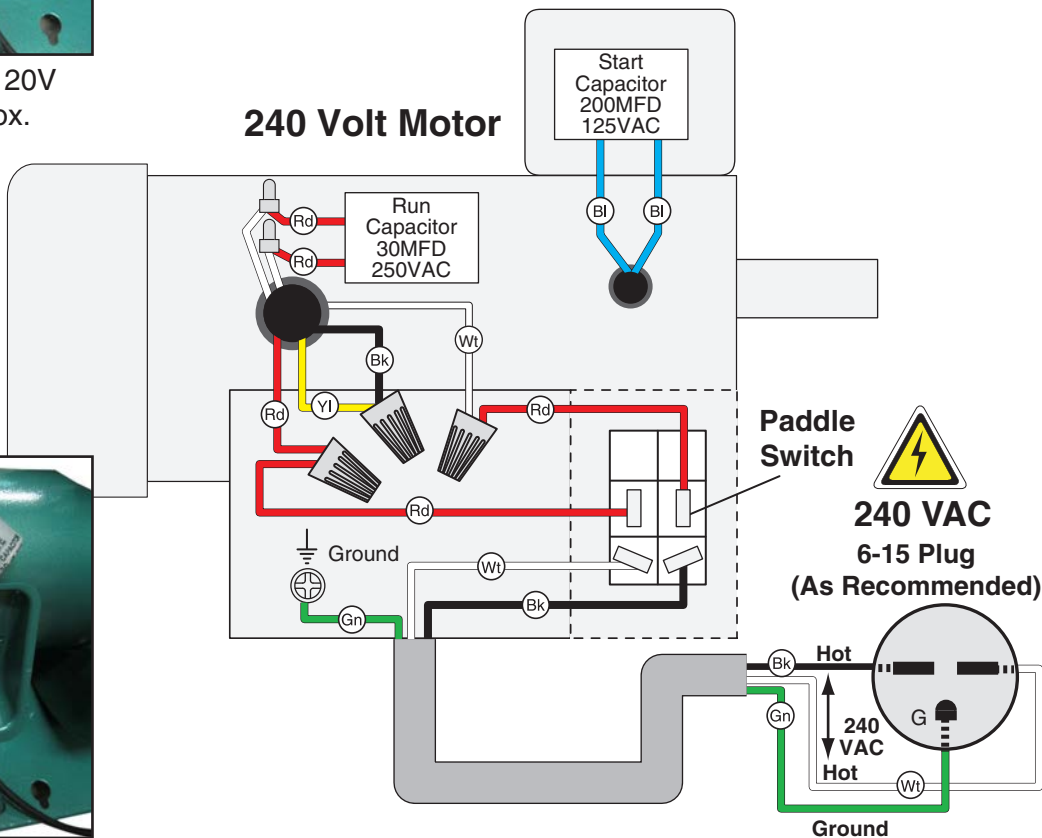
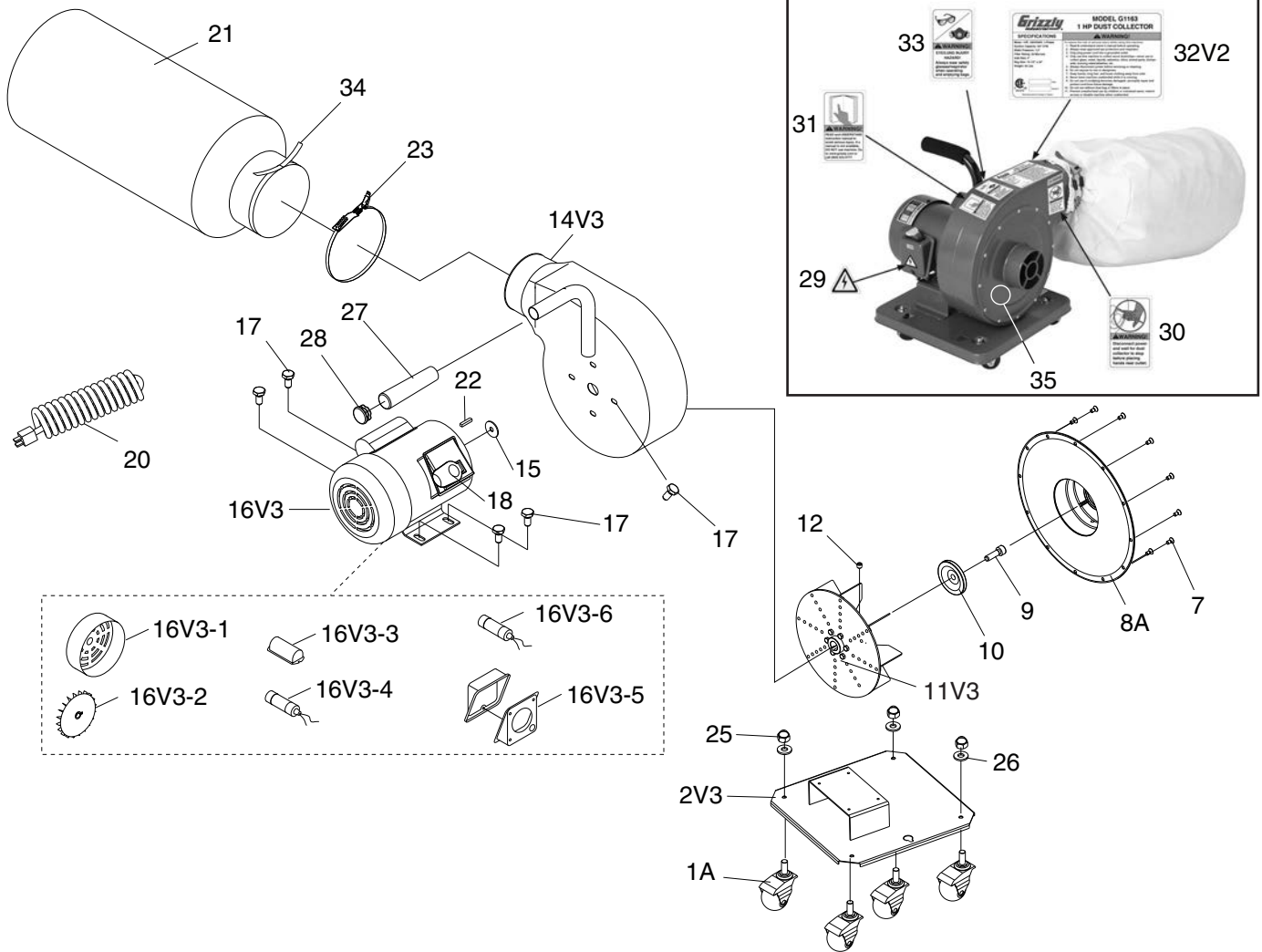

Figure 22. 240V junction box.



SECTION 9: PARTS

G1163 Main Breakdown



REF	PART #	DESCRIPTION
1A	P1163001A	CASTER V2.09.01
2V3	P1163002V3	BASE V3.12.09
7	PS09M	PHLP HD SCR M5-.8 X 10
8A	P1163008A	INLET COVER 11" V2.01.06
9	PSB121M	CAP SCREW M6-1 X 20 (LH)
10	P1028009	MOTOR FAN WASHER
11V3	P1163011V3	IMPELLER 10", CAST ALUMINUM V3.09.12
12	PSS02	SET SCREW 5/16-18 X 3/8
14V3	P1163014V3	BODY W HANDLE V3.12.09
15	P1032019	GASKET
16V3	P1163016V3	MOTOR 1HP 120V/240V 1-PH V3.09.11
16V3-1	P1163016V3-1	FAN COVER
16V3-2	P1163016V3-2	MOTOR FAN
16V3-3	P1163016V3-3	CAPACITOR COVER
16V3-4	PC200F	S CAPACITOR 200M 125V 1-3/8 X 2-3/4
16V3-5	P1163016V3-5	JUNCTION BOX
16V3-6	PC30	R CAPACITOR 30M 250V 1-3/8 X 2-1/2

REF	PART #	DESCRIPTION
17	PFB03	FLANGE BOLT 1/4-20 X 1/2
18	G8988	PADDLE SWITCH 110V/220V
20	PWRCRD110L	POWER CORD 16G X 3W 73"L
21	G3591	REPLACEMENT BAG FOR G1163
22	PK23M	KEY 5 X 5 X 25
23	P1163023	CLAMP
25	PN40	ACORN NUT 5/16-18
26	PW07	FLAT WASHER 5/16
27	P1163027	HANDLE COVER
28	PFB03	HANDLE CAP
29	PLABEL-14	ELECTRICITY LABEL
30	P1028Z041	HANDS/OUTLET LABEL
31	PLABEL-12A	READ MANUAL LABEL
32V2	P1163032V2	ID LABEL CSA V2.09.11
33	PLABEL-57	GLASSES/RESPIRATOR LABEL
34	P1163034	FOAM STRIP 4 X 20 X 430MM
35	PPAINT-1	GRIZZLY GREEN PAINT



G1163P Main Breakdown

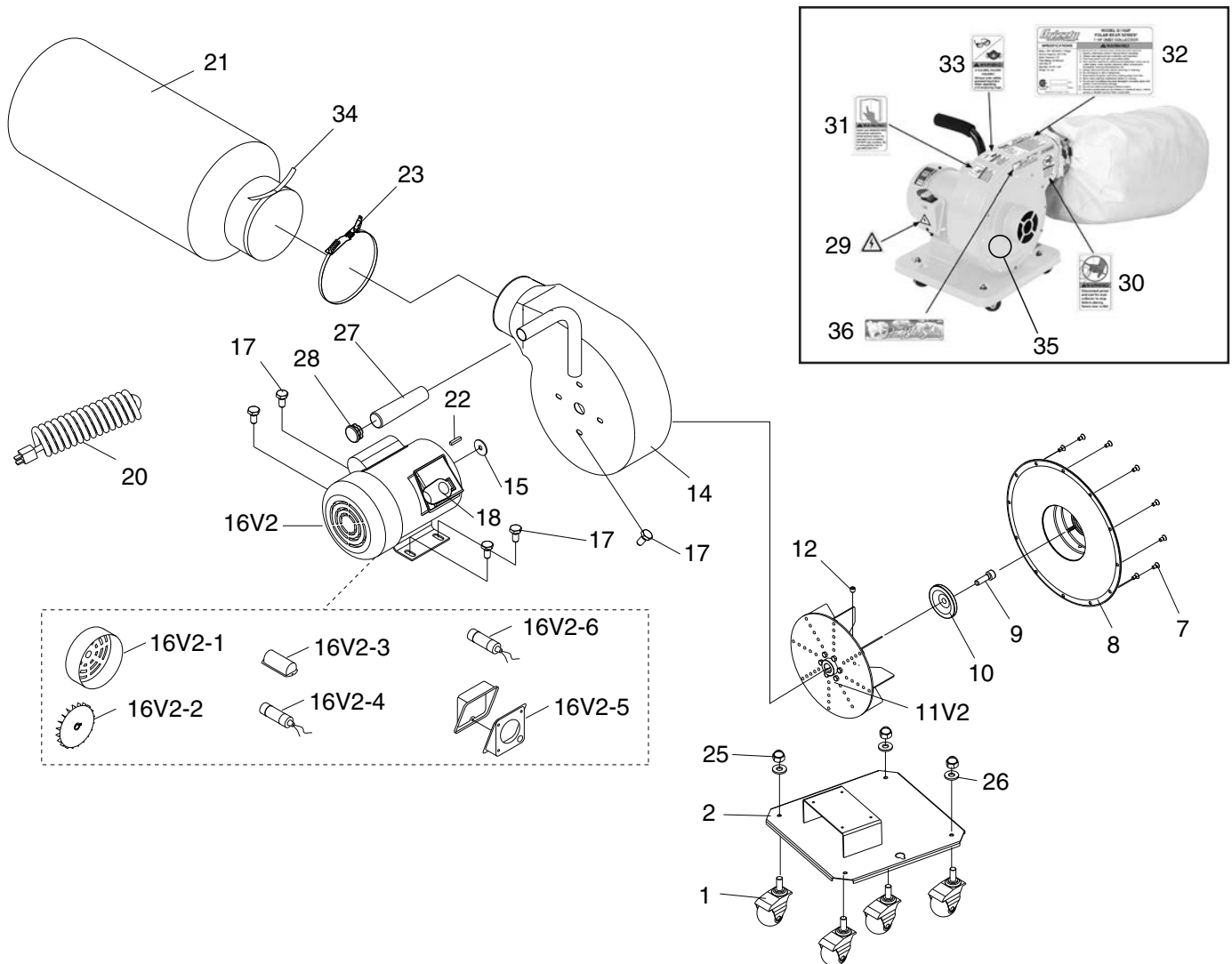

REF	PART #	DESCRIPTION
1	P1163001A	CASTER
2	P1163P002	BASE
7	PS09M	PHLP HD SCR M5-.8 X 10
8	P1163P008	INLET COVER
9	PSB121M	CAP SCREW M6-1 X 20 (LH)
10	P1028009	MOTOR FAN WASHER
11V2	P1163P011V2	IMPELLER 10", CAST ALUMINUM V2.09.12
12	PSS02	SET SCREW 5/16-18 X 3/8
14	P1163P014	COLLECTOR BODY W/ HANDLE
15	P1032019	GASKET
16V2	P1163P016V2	MOTOR 1HP 120V/240V 1-PH V2.09.11
16V2-1	P1163P016V2-1	FAN COVER
16V2-2	P1163P016V2-2	MOTOR FAN
16V2-3	P1163P016V2-3	CAPACITOR COVER
16V2-4	PC200F	S CAPACITOR 200M 125V 1-3/8 X 2-3/4
16V2-5	P1163P016V2-5	JUNCTION BOX
16V2-6	PC30	R CAPACITOR 30M 250V 1-3/8 X 2-1/2
17	PFB03	FLANGE BOLT 1/4-20 X 1/2

REF	PART #	DESCRIPTION
18	G8988	PADDLE SWITCH 110V/220V W/KEY
20	PWRCRD110L	POWER CORD 16G X 3W 73"L 5-15
21	G3591	REPLACEMENT BAG FOR G1163
22	PK23M	KEY 5 X 5 X 25
23	P1163023	CLAMP
25	PN40	ACORN NUT 5/16-18
26	PW07	FLAT WASHER 5/16
27	P1163027	HANDLE COVER
28	P1163028	HANDLE CAP
29	PLABEL-14	ELECTRICITY LABEL
30	P1028Z041	HANDS/OUTLET LABEL
31	PLABEL-12A	READ MANUAL LABEL
32	P1163P032	MACHINE ID LABEL CSA
33	PLABEL-57	GLASSES/RESPIRATOR LABEL
34	P1163034	FOAM STRIP 4 X 20 X 430MM
35	PPAINT-24	POLAR BEAR WHITE PAINT
36	PLABEL-81	POLAR BEAR LOGO 1 X 3-3/4





WARRANTY CARD

Name _____
 Street _____
 City _____ State _____ Zip _____
 Phone # _____ Email _____
 Model # _____ Order # _____ Serial # _____

The following information is given on a voluntary basis. It will be used for marketing purposes to help us develop better products and services. **Of course, all information is strictly confidential.**

1. How did you learn about us?

Advertisement Friend Catalog
 Card Deck Website Other:

2. Which of the following magazines do you subscribe to?

<input type="checkbox"/> Cabinetmaker & FDM	<input type="checkbox"/> Popular Science	<input type="checkbox"/> Wooden Boat
<input type="checkbox"/> Family Handyman	<input type="checkbox"/> Popular Woodworking	<input type="checkbox"/> Woodshop News
<input type="checkbox"/> Hand Loader	<input type="checkbox"/> Precision Shooter	<input type="checkbox"/> Woodsmith
<input type="checkbox"/> Handy	<input type="checkbox"/> Projects in Metal	<input type="checkbox"/> Woodwork
<input type="checkbox"/> Home Shop Machinist	<input type="checkbox"/> RC Modeler	<input type="checkbox"/> Woodworker West
<input type="checkbox"/> Journal of Light Cont.	<input type="checkbox"/> Rifle	<input type="checkbox"/> Woodworker's Journal
<input type="checkbox"/> Live Steam	<input type="checkbox"/> Shop Notes	<input type="checkbox"/> Other:
<input type="checkbox"/> Model Airplane News	<input type="checkbox"/> Shotgun News	
<input type="checkbox"/> Old House Journal	<input type="checkbox"/> Today's Homeowner	
<input type="checkbox"/> Popular Mechanics	<input type="checkbox"/> Wood	

3. What is your annual household income?

\$20,000-\$29,000 \$30,000-\$39,000 \$40,000-\$49,000
 \$50,000-\$59,000 \$60,000-\$69,000 \$70,000+

4. What is your age group?

20-29 30-39 40-49
 50-59 60-69 70+

5. How long have you been a woodworker/metalworker?

0-2 Years 2-8 Years 8-20 Years 20+ Years

6. How many of your machines or tools are Grizzly?

0-2 3-5 6-9 10+

7. Do you think your machine represents a good value? Yes No

8. Would you recommend Grizzly Industrial to a friend? Yes No

9. Would you allow us to use your name as a reference for Grizzly customers in your area?

Note: We never use names more than 3 times. Yes No

10. Comments: _____

CUT ALONG DOTTED LINE

FOLD ALONG DOTTED LINE



Place
Stamp
Here



GRIZZLY INDUSTRIAL, INC.
P.O. BOX 2069
BELLINGHAM, WA 98227-2069



FOLD ALONG DOTTED LINE

Send a Grizzly Catalog to a friend:

Name _____
Street _____
City _____ State _____ Zip _____

TAPE ALONG EDGES--PLEASE DO NOT STAPLE

WARRANTY & RETURNS

Grizzly Industrial, Inc. warrants every product it sells for a period of **1 year** to the original purchaser from the date of purchase. This warranty does not apply to defects due directly or indirectly to misuse, abuse, negligence, accidents, repairs or alterations or lack of maintenance. This is Grizzly's sole written warranty and any and all warranties that may be implied by law, including any merchantability or fitness, for any particular purpose, are hereby limited to the duration of this written warranty. We do not warrant or represent that the merchandise complies with the provisions of any law or acts unless the manufacturer so warrants. In no event shall Grizzly's liability under this warranty exceed the purchase price paid for the product and any legal actions brought against Grizzly shall be tried in the State of Washington, County of Whatcom.

We shall in no event be liable for death, injuries to persons or property or for incidental, contingent, special, or consequential damages arising from the use of our products.

To take advantage of this warranty, contact us by mail or phone and give us all the details. We will then issue you a "Return Number," which must be clearly posted on the outside as well as the inside of the carton. We will not accept any item back without this number. Proof of purchase must accompany the merchandise.

The manufacturers reserve the right to change specifications at any time because they constantly strive to achieve better quality equipment. We make every effort to ensure that our products meet high quality and durability standards and we hope you never need to use this warranty.

Please feel free to write or call us if you have any questions about the machine or the manual.

Thank you again for your business and continued support. We hope to serve you again soon.

grizzly.com[®]
TOOL WEBSITE

Buy Direct and Save with Grizzly[®] – Trusted, Proven and a Great Value!
~Since 1983~

*Visit Our Website Today For
Current Specials!*

**ORDER
24 HOURS A DAY!
1-800-523-4777**

