

Grizzly **Industrial, Inc.**®

MODEL G0679 **STROKE/EDGE SANDER** **OWNER'S MANUAL** *(For models manufactured since 11/11)*



COPYRIGHT © OCTOBER, 2008 BY GRIZZLY INDUSTRIAL, INC., REVISED NOVEMBER, 2017 (HE)
**WARNING: NO PORTION OF THIS MANUAL MAY BE REPRODUCED IN ANY SHAPE
OR FORM WITHOUT THE WRITTEN APPROVAL OF GRIZZLY INDUSTRIAL, INC.**

#JB11085 PRINTED IN TAIWAN

V2.11.17



WARNING!

This manual provides critical safety instructions on the proper setup, operation, maintenance, and service of this machine/tool. Save this document, refer to it often, and use it to instruct other operators.

Failure to read, understand and follow the instructions in this manual may result in fire or serious personal injury—including amputation, electrocution, or death.

The owner of this machine/tool is solely responsible for its safe use. This responsibility includes but is not limited to proper installation in a safe environment, personnel training and usage authorization, proper inspection and maintenance, manual availability and comprehension, application of safety devices, cutting/sanding/grinding tool integrity, and the usage of personal protective equipment.

The manufacturer will not be held liable for injury or property damage from negligence, improper training, machine modifications or misuse.



WARNING!

Some dust created by power sanding, sawing, grinding, drilling, and other construction activities contains chemicals known to the State of California to cause cancer, birth defects or other reproductive harm. Some examples of these chemicals are:

- **Lead from lead-based paints.**
- **Crystalline silica from bricks, cement and other masonry products.**
- **Arsenic and chromium from chemically-treated lumber.**

Your risk from these exposures varies, depending on how often you do this type of work. To reduce your exposure to these chemicals: Work in a well ventilated area, and work with approved safety equipment, such as those dust masks that are specially designed to filter out microscopic particles.

Table of Contents

INTRODUCTION	2	SECTION 5: ACCESSORIES	29
Manual Accuracy	2	SECTION 6: MAINTENANCE	31
Contact Info.....	2	Schedule	31
Functional Overview	2	Cleaning.....	31
Identification.....	3	Lubrication	31
Machine Data Sheet	4	SECTION 7: SERVICE	33
SECTION 1: SAFETY	6	Troubleshooting	33
Safety Instructions for Machinery	6	Table Bearings.....	35
Additional Safety for Stroke/Edge Sanders ...	8	90° Stop	35
SECTION 2: POWER SUPPLY	9	Belt Tracking.....	36
220V Operation.....	9	Table Elevation Wear Pin Adjustment	37
SECTION 3: SETUP	10	SECTION 8: WIRING	38
Setup Safety	10	Wiring Safety Instructions	38
Items Needed for Setup.....	10	Wiring Diagram	39
Unpacking	10	SECTION 9: PARTS	40
Inventory	11	Main Breakdown	40
Hardware Recognition Chart	13	Belt & Idler Wheel Assembly Breakdown	42
Clean Up	14	Gearbox & Table Breakdown & Parts List...	44
Site Considerations.....	14	Left Upright Assembly Breakdown.....	47
Assembly	15	Platen Press Assembly	49
Machine Leveling.....	20	Breakdown & Parts List	49
Dust Collection.....	21	Labels Breakdown & Parts List.....	50
Test Run	21	WARRANTY AND RETURNS	53
SECTION 4: OPERATIONS	22		
Operation Safety	22		
Basic Controls.....	22		
Table Movement	23		
Workstops	24		
Stroke/Edge Sander Conversion	25		
Belt Replacement.....	27		
Platen Press Movement.....	28		
Basic Operations.....	28		

INTRODUCTION

Manual Accuracy

We are proud to offer this manual with your new machine! We've made every effort to be exact with the instructions, specifications, drawings, and photographs of the machine we used when writing this manual. However, sometimes errors do happen and we apologize for them.

Also, owing to our policy of continuous improvement, **your machine may not exactly match the manual**. If you find this to be the case, and the difference between the manual and machine leaves you in doubt, immediately call our technical support for updates or clarification.

For your convenience, we always keep current Grizzly manuals and most updates available on our website at www.grizzly.com. Any updates to your machine will be reflected in these documents as soon as they are complete. Visit our site often to check for the latest updates!

Contact Info

We stand behind our machines! If you have questions or need help, contact us with the information below. Before contacting, make sure you get the **serial number** and **manufacture date** from the machine ID label. This will help us help you faster.

Grizzly Technical Support
1815 W. Battlefield
Springfield, MO 65807
Phone: (570) 546-9663
Email: techsupport@grizzly.com

We want your feedback on this manual. What did you like about it? Where could it be improved? Please take a few minutes to give us feedback.

Grizzly Documentation Manager
P.O. Box 2069
Bellingham, WA 98227-2069
Email: manuals@grizzly.com

Functional Overview

The Model G0679 Stroke/Edge Sander is used to sand large workpieces such as tabletops or doors. For maximum versatility, the belt assembly pivots from horizontal to vertical to allow for edge sanding. When in the horizontal position, the platen press is used to apply sanding pressure to the workpiece and when in the vertical position, the workpiece is pressed into the belt to apply sanding pressure.

To use the sander in the stroke sanding mode, the user locks the belt assembly in the horizontal position, then places the workpiece on the table and raises the table until the workpiece is within $\frac{1}{4}$ " of the belt. The user positions the workstops as necessary to ensure workpiece stability, then turns the machine **ON**. The user grasps the table handle with one hand and the platen press handle with the other, then applies pressure by pulling the platen press handle downward while sliding the handle back-and-forth along the entire length of the workpiece. To sand the full width of the workpiece, the user moves the table forward-and-backward.

To use the sander in the edge sanding mode, the user adjusts the belt assembly to the desired angle, locks it in place, then opens the belt cover to expose the belt. The user raises the table until it is even with the center portion of the belt, then places the workpiece on the table and positions the workstops as necessary to ensure workpiece stability. The machine is turned **ON**, and the user moves the workpiece into the belt to perform the sanding operation.



Identification

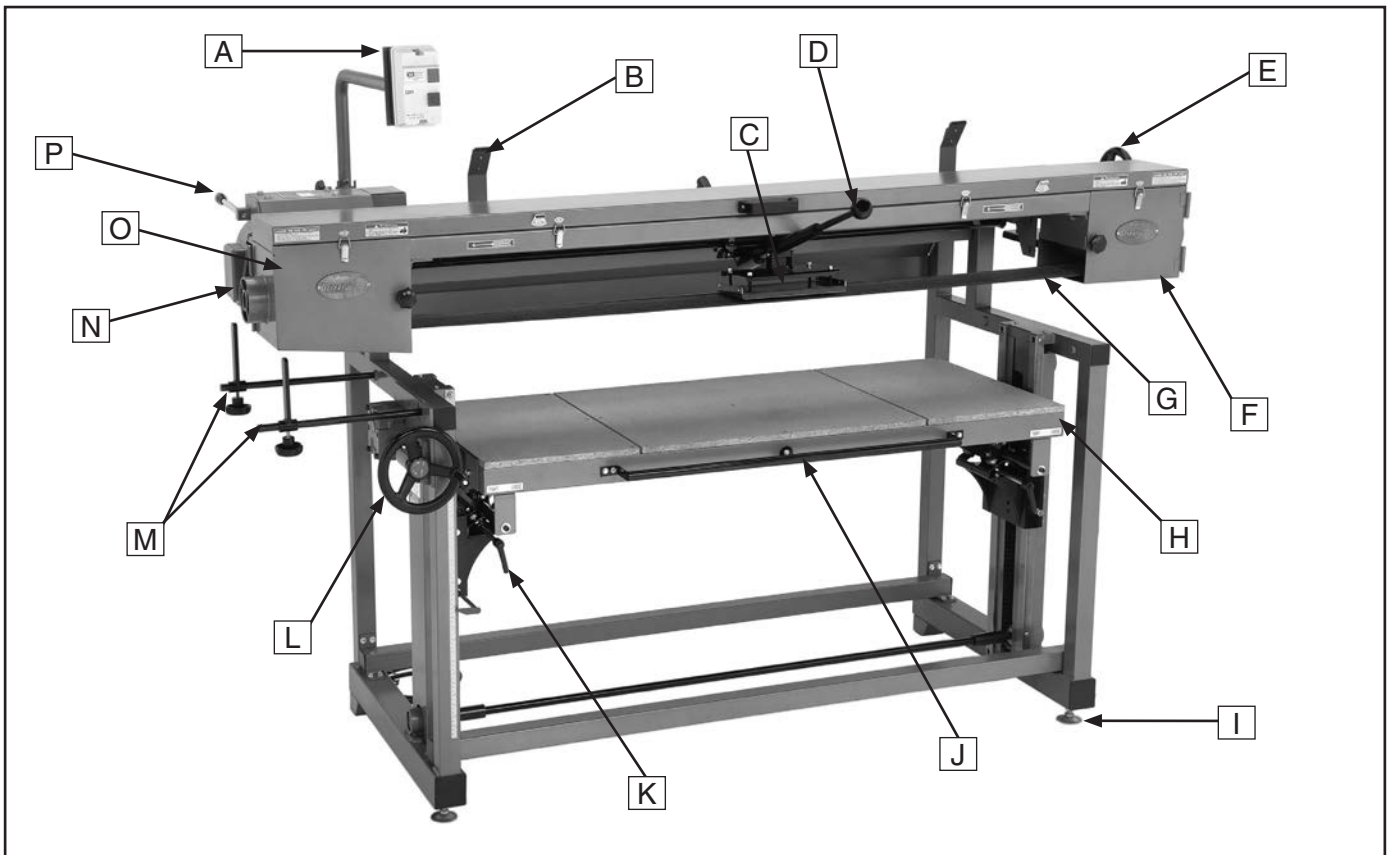

Figure 1. Identification.

- A. Magnetic On/Off Switch
- B. Belt Cover Open Latch
- C. Platen Press
- D. Platen Press Handle
- E. Belt Tension Handwheel
- F. Idler Wheel Cover
- G. Sanding Belt
- H. Table
- I. Adjustable Foot
- J. Table Handle
- K. Table Travel Lock
- L. Table Elevation Handwheel
- M. Work Stops
- N. Dust Collection Port
- O. Drive Wheel Cover
- P. Belt Tilt Lever





MACHINE DATA SHEET

Customer Service #: (570) 546-9663 · To Order Call: (800) 523-4777 · Fax #: (800) 438-5901

MODEL G0679 6" X 186" 3 HP 220V STROKE SANDER

Product Dimensions:

Weight..... 608 lbs.
 Width (side-to-side) x Depth (front-to-back) x Height..... 98 x 47-5/8 x 67-1/2 in.
 Footprint (Length x Width)..... 69-1/4 x 31 in.

Shipping Dimensions:

Type..... Wood Crate
 Content..... Machine
 Weight..... 744 lbs.
 Length x Width x Height..... 36 x 87 x 23 in.
 Must Ship Upright..... Yes

Electrical:

Power Requirement..... 220V, Single-Phase, 60 Hz
 Prewired Voltage..... 220V
 Full-Load Current Rating..... 17A
 Minimum Circuit Size..... 30A
 Connection Type..... Cord & Plug
 Power Cord Included..... Yes
 Power Cord Length..... 6 ft.
 Power Cord Gauge..... 14 AWG
 Plug Included..... No
 Recommended Plug Type..... L6-30
 Switch Type..... Magnetic Switch w/Overload Protection

Motors:

Main

Horsepower..... 3 HP
 Phase..... Single-Phase
 Amps..... 17A
 Speed..... 1750 RPM
 Type..... TEFC Capacitor-Start Induction
 Power Transfer..... Direct Drive
 Bearings..... Shielded & Permanently Lubricated

Main Specifications:

Operation Information

Sanding Belt Speed..... 3600 FPM
 Sanding Belt Length..... 186 in.
 Sanding Belt Width..... 6 in.

Table Information

Table Length..... 59 in.
 Table Width..... 23-3/4 in.
 Table Thickness..... 3 in.
 Table Travel..... 18 in.
 Floor To Table Height..... 21-3/8 – 42-3/4 in.



Platen Information

Platen Type..... Graphite Coated
Platen Length..... 6 in. x 10-1/2 in. (Movable)
Platen Width..... 6 in.
Platen Travel..... 50-1/2 in.

Construction

Table..... Steel w/Composite Wood Top
Frame..... Steel
Base..... Steel
Drive Roller..... Aluminum
Paint Type/Finish..... Powder Coated

Other Related Information

Number of Dust Ports..... 2
Dust Port Size..... 4 in.

Other Specifications:

Country of Origin Taiwan
Warranty 1 Year
Approximate Assembly & Setup Time 3 Hours
Serial Number Location ID Label on Front of Machine
ISO 9001 Factory Yes
Certified by a Nationally Recognized Testing Laboratory (NRTL) No

Features:

- 21 In. Maximum Workpiece Thickness
- Horizontal Belt Position for Stroke Sanding and Vertical Belt Position for Edge Sanding
- Sliding Ways Travel on Ball Bearings
- Fully Adjustable Belt Tracking and Tension
- Motor Brake Quickly Stops Belt Movement



SECTION 1: SAFETY

For Your Own Safety, Read Instruction Manual Before Operating This Machine

The purpose of safety symbols is to attract your attention to possible hazardous conditions. This manual uses a series of symbols and signal words intended to convey the level of importance of the safety messages. The progression of symbols is described below. Remember that safety messages by themselves do not eliminate danger and are not a substitute for proper accident prevention measures. Always use common sense and good judgment.

 **DANGER** Indicates an imminently hazardous situation which, if not avoided, **WILL** result in death or serious injury.

 **WARNING** Indicates a potentially hazardous situation which, if not avoided, **COULD** result in death or serious injury.

 **CAUTION** Indicates a potentially hazardous situation which, if not avoided, **MAY** result in minor or moderate injury. It may also be used to alert against unsafe practices.

NOTICE This symbol is used to alert the user to useful information about proper operation of the machine.

Safety Instructions for Machinery

WARNING

OWNER'S MANUAL. Read and understand this owner's manual **BEFORE** using machine.

TRAINED OPERATORS ONLY. Untrained operators have a higher risk of being hurt or killed. Only allow trained/supervised people to use this machine. When machine is not being used, disconnect power, remove switch keys, or lock-out machine to prevent unauthorized use—especially around children. Make your workshop kid proof!

DANGEROUS ENVIRONMENTS. Do not use machinery in areas that are wet, cluttered, or have poor lighting. Operating machinery in these areas greatly increases the risk of accidents and injury.

MENTAL ALERTNESS REQUIRED. Full mental alertness is required for safe operation of machinery. Never operate under the influence of drugs or alcohol, when tired, or when distracted.

ELECTRICAL EQUIPMENT INJURY RISKS. You can be shocked, burned, or killed by touching live electrical components or improperly grounded machinery. To reduce this risk, only allow qualified service personnel to do electrical installation or repair work, and always disconnect power before accessing or exposing electrical equipment.

DISCONNECT POWER FIRST. Always disconnect machine from power supply **BEFORE** making adjustments, changing tooling, or servicing machine. This prevents an injury risk from unintended startup or contact with live electrical components.

EYE PROTECTION. Always wear ANSI-approved safety glasses or a face shield when operating or observing machinery to reduce the risk of eye injury or blindness from flying particles. Everyday eyeglasses are **NOT** approved safety glasses.



WARNING

WEARING PROPER APPAREL. Do not wear clothing, apparel or jewelry that can become entangled in moving parts. Always tie back or cover long hair. Wear non-slip footwear to reduce risk of slipping and losing control or accidentally contacting cutting tool or moving parts.

HAZARDOUS DUST. Dust created by machinery operations may cause cancer, birth defects, or long-term respiratory damage. Be aware of dust hazards associated with each workpiece material. Always wear a NIOSH-approved respirator to reduce your risk.

HEARING PROTECTION. Always wear hearing protection when operating or observing loud machinery. Extended exposure to this noise without hearing protection can cause permanent hearing loss.

REMOVE ADJUSTING TOOLS. Tools left on machinery can become dangerous projectiles upon startup. Never leave chuck keys, wrenches, or any other tools on machine. Always verify removal before starting!

USE CORRECT TOOL FOR THE JOB. Only use this tool for its intended purpose—do not force it or an attachment to do a job for which it was not designed. Never make unapproved modifications—modifying tool or using it differently than intended may result in malfunction or mechanical failure that can lead to personal injury or death!

AWKWARD POSITIONS. Keep proper footing and balance at all times when operating machine. Do not overreach! Avoid awkward hand positions that make workpiece control difficult or increase the risk of accidental injury.

CHILDREN & BYSTANDERS. Keep children and bystanders at a safe distance from the work area. Stop using machine if they become a distraction.

GUARDS & COVERS. Guards and covers reduce accidental contact with moving parts or flying debris. Make sure they are properly installed, undamaged, and working correctly BEFORE operating machine.

FORCING MACHINERY. Do not force machine. It will do the job safer and better at the rate for which it was designed.

NEVER STAND ON MACHINE. Serious injury may occur if machine is tipped or if the cutting tool is unintentionally contacted.

STABLE MACHINE. Unexpected movement during operation greatly increases risk of injury or loss of control. Before starting, verify machine is stable and mobile base (if used) is locked.

USE RECOMMENDED ACCESSORIES. Consult this owner's manual or the manufacturer for recommended accessories. Using improper accessories will increase the risk of serious injury.

UNATTENDED OPERATION. To reduce the risk of accidental injury, turn machine **OFF** and ensure all moving parts completely stop before walking away. Never leave machine running while unattended.

MAINTAIN WITH CARE. Follow all maintenance instructions and lubrication schedules to keep machine in good working condition. A machine that is improperly maintained could malfunction, leading to serious personal injury or death.

DAMAGED PARTS. Regularly inspect machine for damaged, loose, or mis-adjusted parts—or any condition that could affect safe operation. Immediately repair/replace BEFORE operating machine. For your own safety, DO NOT operate machine with damaged parts!

MAINTAIN POWER CORDS. When disconnecting cord-connected machines from power, grab and pull the plug—NOT the cord. Pulling the cord may damage the wires inside. Do not handle cord/plug with wet hands. Avoid cord damage by keeping it away from heated surfaces, high traffic areas, harsh chemicals, and wet/damp locations.

EXPERIENCING DIFFICULTIES. If at any time you experience difficulties performing the intended operation, stop using the machine! Contact our Technical Support at (570) 546-9663.



WARNING

Additional Safety for Stroke/Edge Sanders

- 1. RESPIRATOR AND SAFETY GLASSES.** Always wear a respirator and safety glasses while operating the machine. Dust and chips are created when sanding. Some debris will be ejected, becoming hazards to the eyes and lungs.
- 2. DUST COLLECTION SYSTEM.** Never operate the sander without an adequate dust collection system in place and running.
- 3. HAND PROTECTION.** DO NOT place hands near, or in contact with, sanding belt during operation. DO NOT allow fingers to get pinched between the workpiece and the table. This may pull the operator's hand into the machine and cause serious injury!
- 4. INSPECTING WORKPIECES.** Always inspect workpiece for nails, staples, knots, and other imperfections that could be dislodged and thrown from the machine during sanding operations.
- 5. SANDING CORRECT MATERIAL.** Only sand natural wood stock with this sander. We do not recommend sanding MDF, particle board, laminates, plastics, metal, glass, ceramics, and any other synthetic products, or products containing asbestos or lead paint. Many of these products contain hazardous dust, or will greatly reduce the life of your sanding paper.
- 6. UNATTENDED OPERATION.** Never leave the machine running unattended.
- 7. CLOTHING.** DO NOT wear loose clothing while operating this machine. Roll up or button sleeves at the cuff.
- 8. FEEDING STOCK WHEN EDGE SANDING.** Firmly grasp the workpiece with both hands and ease it into the machine using light pressure. DO NOT jam the workpiece into the machine during operation. Feed the workpiece against the direction of rotation. DO NOT sand tapered or pointed stock with the point facing into the feed direction. Never sand more than one piece of stock at a time.
- 9. REPLACING SANDPAPER.** Replace sanding paper when it becomes worn. DO NOT operate the sander with a damaged or badly worn sandpaper.
- 10. MAINTENANCE AND ADJUSTMENTS.** Perform machine inspections and maintenance service promptly when called for. Disconnect power before performing maintenance or adjustments on the sander.
- 11. EXPERIENCING DIFFICULTIES.** Any problem, with the exception of conveyor belt tracking that is concerned with any moving parts or accessories, must be investigated and corrected with the power disconnected, and after all moving parts have come to a complete stop.

WARNING

Like all machinery there is potential danger when operating this machine. Accidents are frequently caused by lack of familiarity or failure to pay attention. Use this machine with respect and caution to decrease the risk of operator injury. If normal safety precautions are overlooked or ignored, serious personal injury may occur.



SECTION 2: POWER SUPPLY

220V Operation

!WARNING

Serious personal injury could occur if you connect the machine to power before completing the setup process. **DO NOT** connect the machine to the power until instructed later in this manual.



!WARNING

Electrocution or fire could result if machine is not grounded and installed in compliance with electrical codes. Compliance **MUST** be verified by a qualified electrician!

Full Load Amperage Draw

This machine draws the following amps under maximum load:

Amp Draw..... 17 Amps

Power Supply Circuit Requirements

You **MUST** connect your machine to a grounded circuit that is rated for the amperage given below. Never replace a circuit breaker on an existing circuit with one of higher amperage without consulting a qualified electrician to ensure compliance with wiring codes. **If you are unsure about the wiring codes in your area or you plan to connect your machine to a shared circuit, consult a qualified electrician.**

Minimum Circuit Size.....30 Amps

Power Connection Device

The type of plug required to connect your machine to power depends on the type of service you currently have or plan to install. We recommend using the plug shown in **Figure 2**.

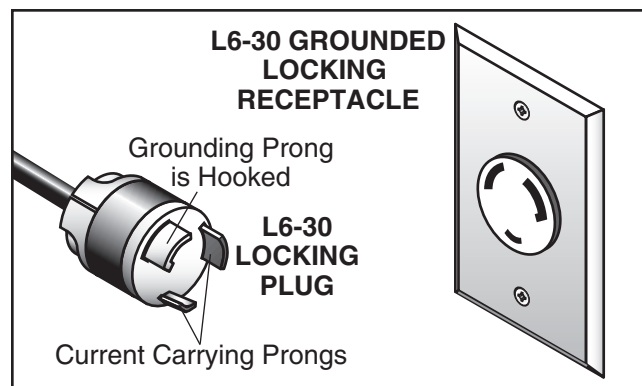

Figure 2. NEMA L6-30 plug and receptacle.

Extension Cords

Using extension cords may reduce the life of the motor. Instead, place the machine near a power source. If you must use an extension cord:

- Use at least a 12 gauge cord that does not exceed 50 feet in length!
- The extension cord must also have a ground wire and plug pin.
- A qualified electrician **MUST** size cords over 50 feet long to prevent motor damage.



SECTION 3: SETUP

Setup Safety

	<p>!WARNING To reduce your risk of serious injury, read this entire manual BEFORE using machine.</p>
---	--

<p>!WARNING To reduce risk of eye injury from flying chips or lung damage from breathing dust, always wear safety glasses and a respirator when operating this machine.</p>
--

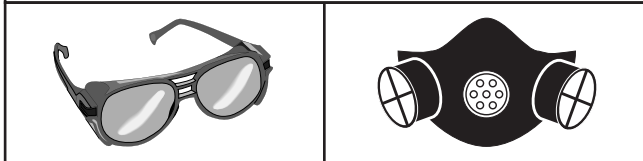

<p>NOTICE If you are not experienced with this type of machine, WE STRONGLY RECOMMEND that you seek additional training outside of this manual. Read books/magazines or get formal training before beginning any projects. Regardless of the content in this section, Grizzly Industrial will not be held liable for accidents caused by lack of training.</p>
--

Items Needed for Setup

The following items are needed to complete the setup process, but are not included with your machine:

Description	Qty
• Assistant.....	1
• Safety Glasses (For Each Person).....	1
• Square.....	1
• Dust Collection System.....	1
• Flexible Dust Hoses 4".....	2
• Hose Clamp 4".....	2

Unpacking

Your machine was carefully packaged for safe transportation. Remove the packaging materials from around your machine and inspect it. If you discover the machine is damaged, *please immediately call Customer Service at (570) 546-9663 for advice.*

Save the containers and all packing materials for possible inspection by the carrier or its agent. *Otherwise, filing a freight claim can be difficult.*

When you are completely satisfied with the condition of your shipment, inventory the contents.



Inventory

The following is a description of the main components shipped with your machine. Lay the components out to inventory them.

Note: If you can't find an item on this list, check the mounting location on the machine or examine the packaging materials carefully. Occasionally we pre-install certain components for shipping purposes.

Inventory A: (Figure 3)	Qty
A. Table Elevation Handwheel	1
B. Belt Tension Handwheel.....	1
C. Work Stops.....	2
D. Belt Tilt Lever	1
E. Belt Tilt Lock Handle	1
F. Wrenches (10/12, 12/14, 17/19mm).....	1 Ea.
G. Switch Boom Knob.....	1
H. Belt Tilt Lock Knobs	2
I. Hex Wrenches (4, 5, 6, 8mm).....	1 Ea.

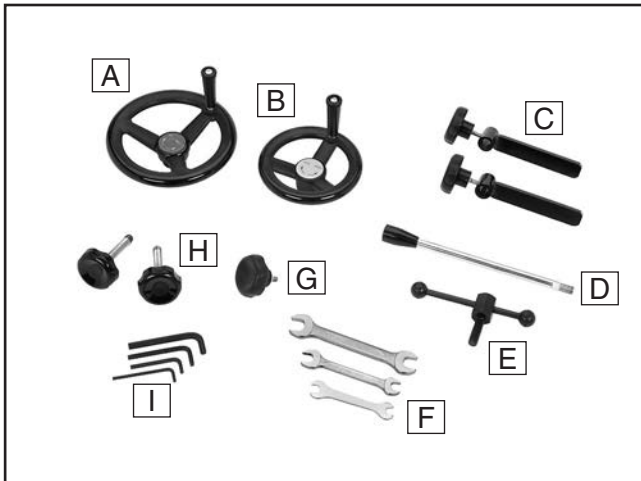

Figure 3. Inventory A.



⚠ WARNING
SUFFOCATION HAZARD!
 Keep children and pets away from plastic bags or packing materials shipped with this machine. Discard immediately.

Inventory B: (Figure 4)	Qty
J. Platen Press Assembly	1
K. Platen Press Counterweight.....	1
L. Belt Cover Latch Brackets.....	2
M. Table Work Stop.....	1

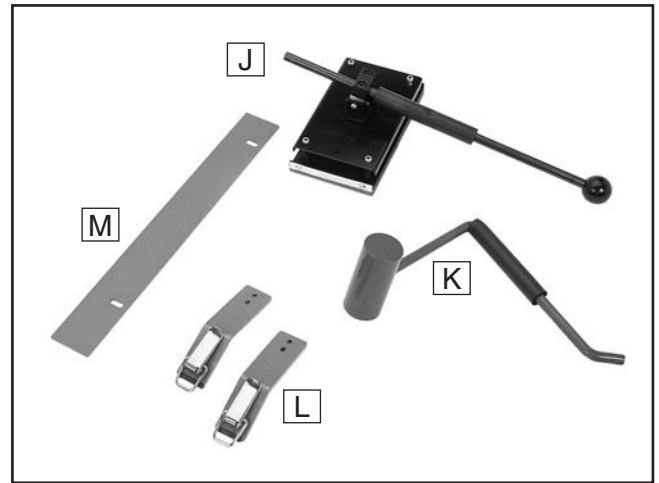

Figure 4. Inventory B.

Inventory C: (Figure 5)	Qty
N. Sanding Belt 6 x 186"	1
O. Table Slide Rods	1
P. Belt Tilt Lock Bracket	1
Q. Work Stop Rods	2
R. Belt Tilt Pivot Bolts	2
S. Lock Nuts 3/8-16	2

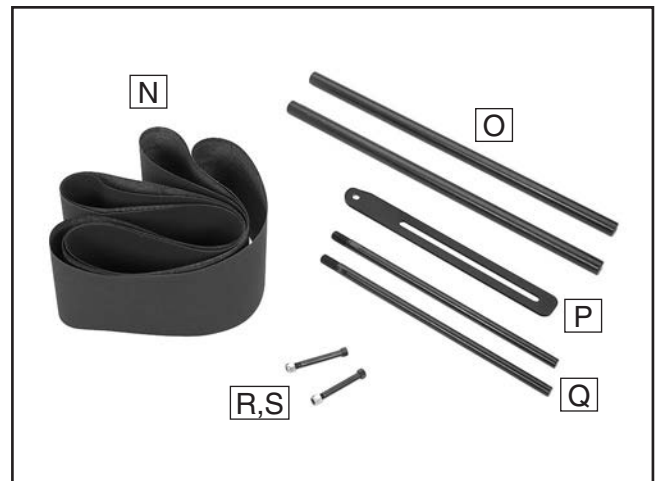

Figure 5. Inventory C.

If any nonproprietary parts are missing (e.g. a nut or a washer), we will gladly replace them; or for the sake of expediency, replacements can be obtained at your local hardware store.



Inventory D: (Figure 6)	Qty
A. Table Assembly	1
B. Idler Wheel Assembly	1

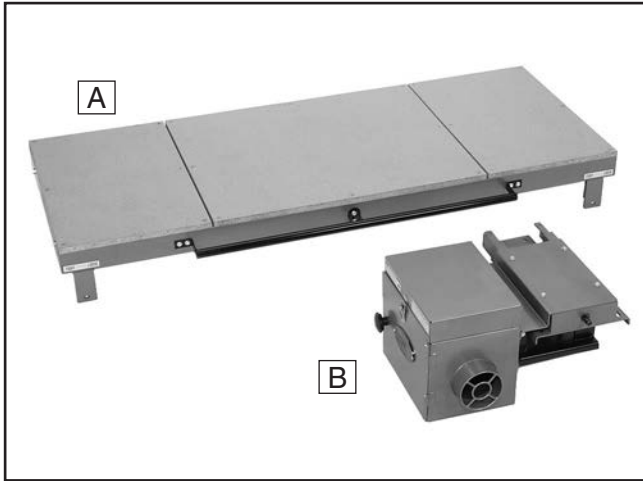

Figure 6. Inventory D.

Inventory E: (Figure 7)	Qty
C. Left Upright Assembly	1
D. Right Upright Assembly	1

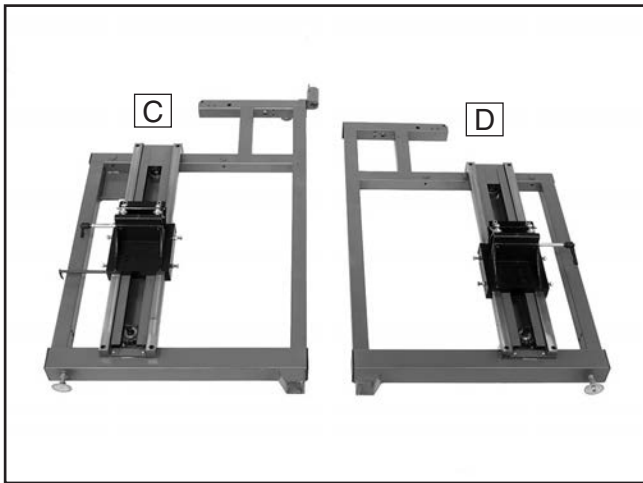

Figure 7. Inventory E.

Hardware Bag: (Not Shown)	Qty
• Flange Bolts $\frac{5}{16}$ -18 x $\frac{1}{2}$ " (Misc.)	32
• Flange Bolts $\frac{1}{4}$ -20 x $\frac{1}{2}$ " (Belt cover, latches)	7
• Cap Screws $\frac{1}{4}$ -20 x $\frac{1}{2}$ " (Platen press rod)	4
• Cap Screws $\frac{5}{16}$ -18 x $\frac{3}{4}$ " (Table)	4
• Flat Washers $\frac{5}{16}$ " (Table)	4
• Phillips Head Screws $\frac{1}{4}$ -20 x $\frac{1}{2}$ " (Rear cover)	6
• Hex Nuts $\frac{1}{4}$ -20 (Belt cover)	3
• Lock Nut $\frac{1}{2}$ "-13 (Pivot lock bracket)	1
• Flat Washers $\frac{1}{2}$ " (Pivot lock knobs)	2

Inventory F: (Figure 8)	Qty
E. Platen Assembly with Motor	1
F. Rear Cover	1
G. Cross Braces	3
H. Platen Rail Assembly	1

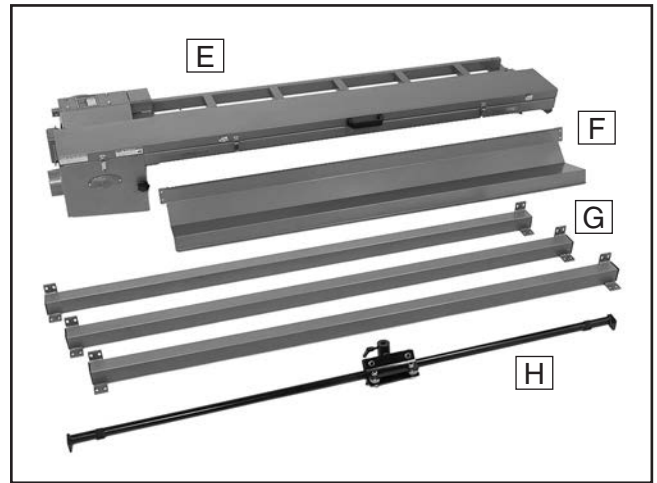

Figure 8. Inventory F.

Inventory G: (Figure 9)	Qty
I. Table Elevation Rod Assembly	1
J. On/Off Switch Boom Assembly	1

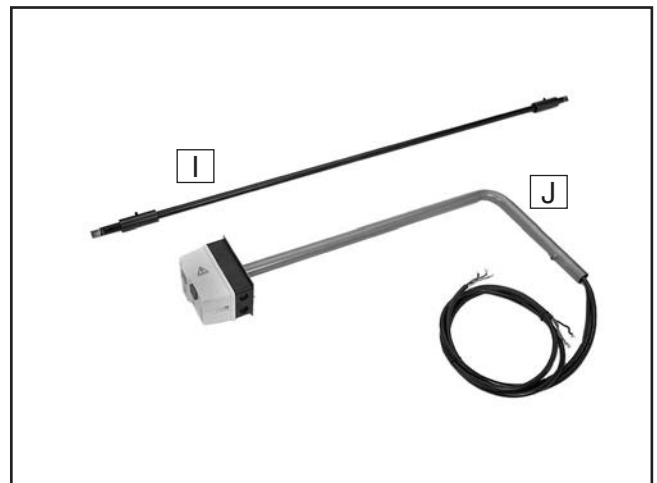

Figure 9. Inventory H.



Hardware Recognition Chart

USE THIS CHART TO MATCH UP HARDWARE DURING THE ASSEMBLY PROCESS.

MEASURE BOLT DIAMETER BY PLACING INSIDE CIRCLE

- #10
- 1/4"
- 5/16"
- 3/8"
- 7/16"
- 1/2"

- 4mm
- 5mm
- 6mm
- 8mm
- 10mm
- 12mm
- 16mm

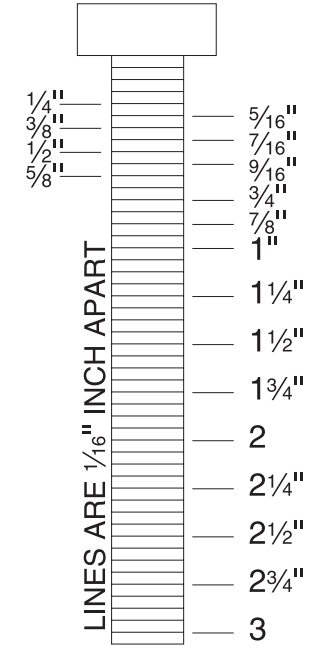
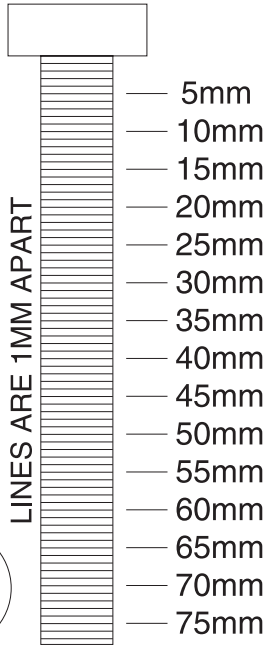
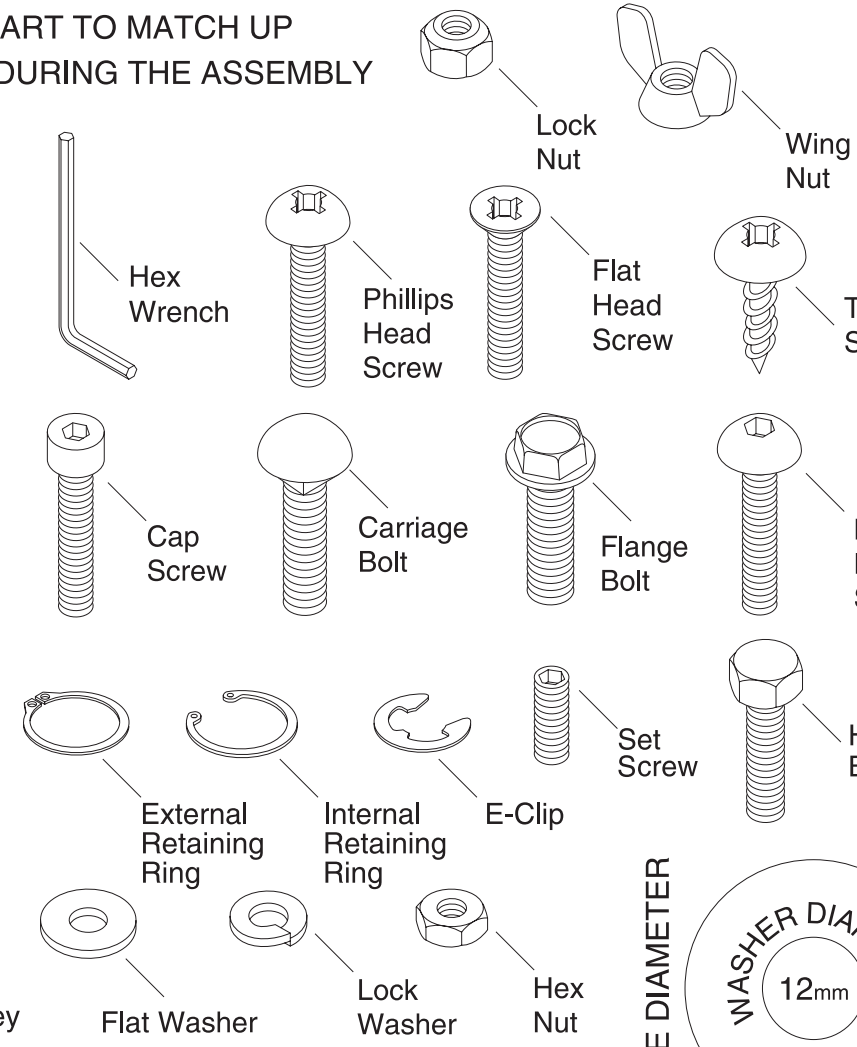

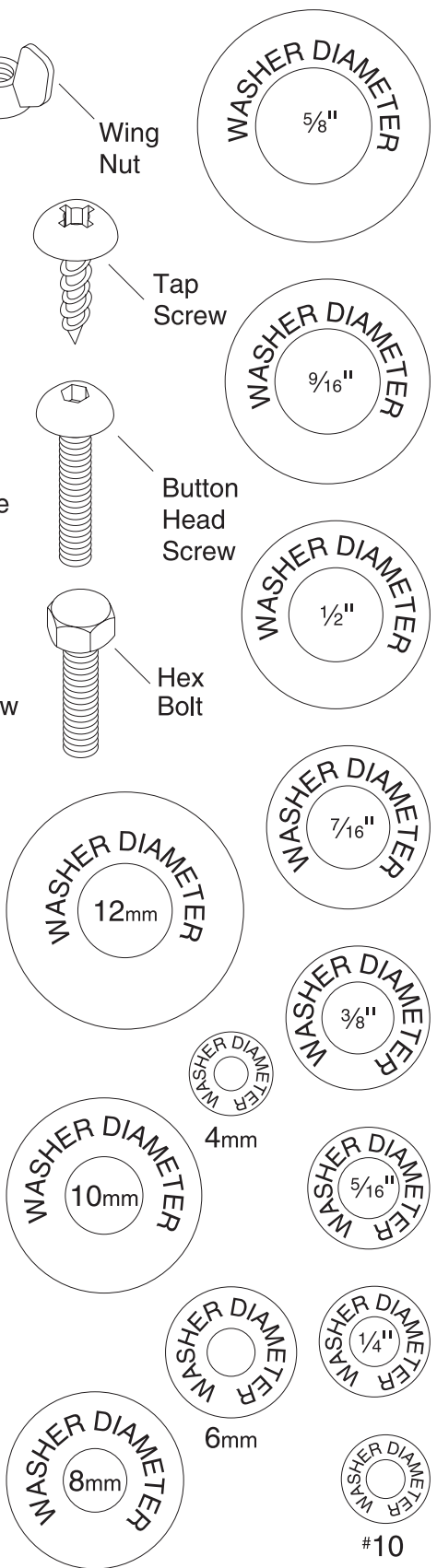

WASHERS ARE MEASURED BY THE INSIDE DIAMETER



Clean Up

The unpainted surfaces are coated with a waxy oil to prevent corrosion during shipment. Remove this protective coating with a solvent cleaner or degreaser, such as shown in **Figure 10**. For thorough cleaning, some parts must be removed. **For optimum performance, clean all moving parts or sliding contact surfaces.** Avoid chlorine-based solvents, such as acetone or brake parts cleaner that may damage painted surfaces. Always follow the manufacturer's instructions when using any type of cleaning product.

	<p>! WARNING Gasoline and petroleum products have low flash points and can explode or cause fire if used to clean machinery. DO NOT use these products to clean the machinery.</p>
---	--

	<p>! CAUTION Many cleaning solvents are toxic if inhaled. Minimize your risk by only using these products in a well ventilated area.</p>
---	---

G2544—Solvent Cleaner & Degreaser
H9692—Orange Power Degreaser
Great products for removing shipping grease.

<p>Call 1-800-523-4777 To Order</p>	
--	---

Figure 10. Cleaner/degreasers available from Grizzly.

Site Considerations

Floor Load

Refer to the **Machine Data Sheet** for the weight and footprint specifications of your machine. Some residential floors may require additional reinforcement to support both the machine and operator.

Placement Location

Consider existing and anticipated needs, size of material to be processed through each machine, and space for auxiliary stands, work tables or other machinery when establishing a location for your new machine. See **Figure 11** for the minimum working clearances.

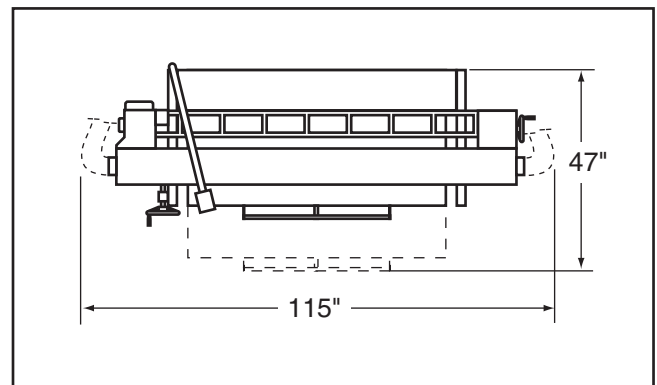
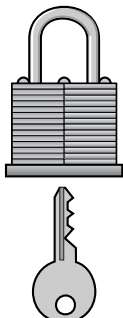

Figure 11. Minimum working clearances.

	<p>! CAUTION Children and visitors may be seriously injured if unsupervised around this machine. Lock entrances to the shop or disable start switch or power connection to prevent unsupervised use.</p>
--	---



Assembly

After you have removed all of the components from the shipping crate and checked the inventory, assemble the machine.

Items required	Qty.
Assistant.....	1
Safety Glasses (For Each Person).....	1 Pair
Square.....	1

To assemble your machine:

1. Connect one of the braces to the lower portion of one of the upright assemblies with (4) $\frac{5}{16}$ -18 x $\frac{1}{2}$ flange bolts, as shown in **Figure 12**. Have an assistant stabilize the upright assembly during fastening. Do not yet fully tighten the bolts.

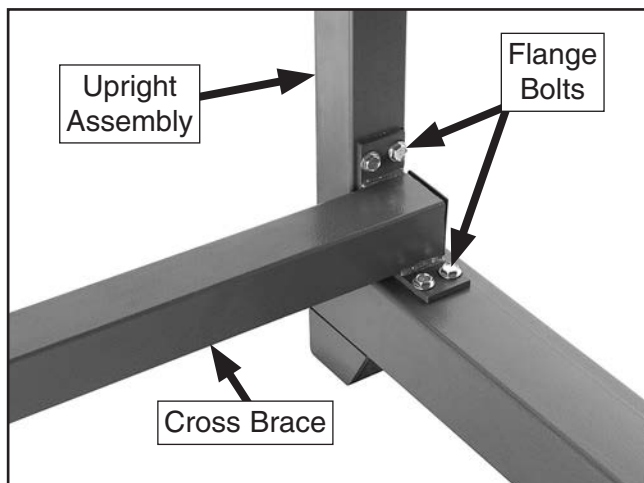

Figure 12. Cross brace attachment.

2. Connect a second cross brace in the same manner.

3. Attach the other upright to the two cross braces with (8) $\frac{5}{16}$ -18 x $\frac{1}{2}$ flange bolts, as shown in **Figure 13**. Have an assistant stabilize the upright assembly during fastening. Do not yet fully tighten the bolts.

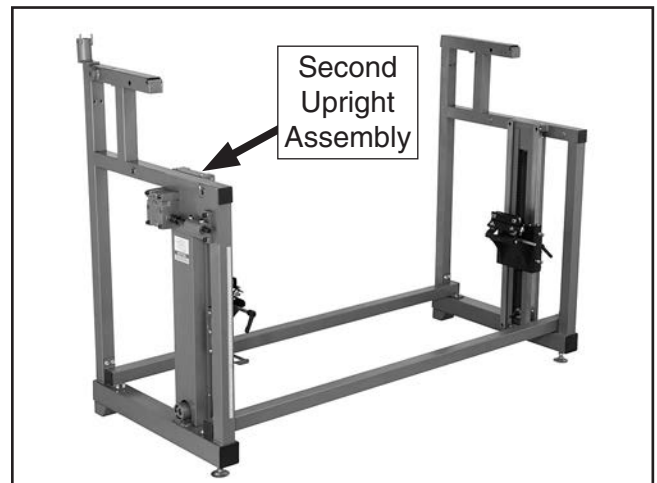

Figure 13. Second upright assembly.

4. Attach the third cross brace to the top location of the uprights with (8) $\frac{5}{16}$ -18 x $\frac{1}{2}$ flange bolts, as shown in **Figure 14**. Use a square to make sure the machine is square vertically and horizontally, then tighten all 24 flange bolts.

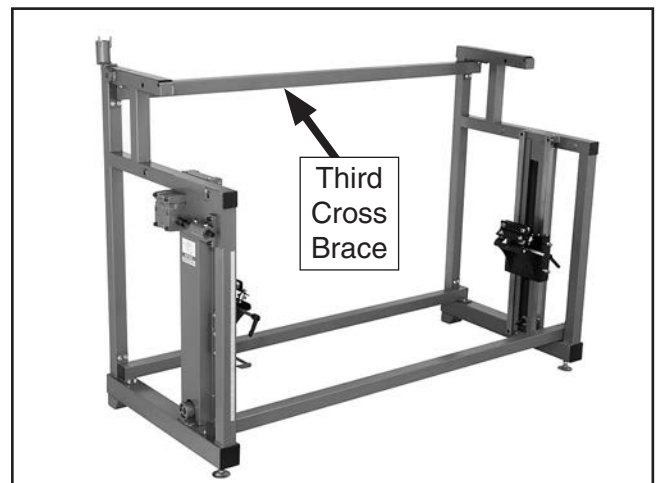

Figure 14. Third cross brace.



5. Connect the table elevation rod to the left and right side elevation assemblies. Place the notch in the end of the rod against the notch in the shaft at the base of the elevation assembly, slide the coupler over the joint, then tighten the set screw, as shown in **Figure 15**.

Note: To make sure both sides are set evenly, fully lower both before connecting the table elevation rod.

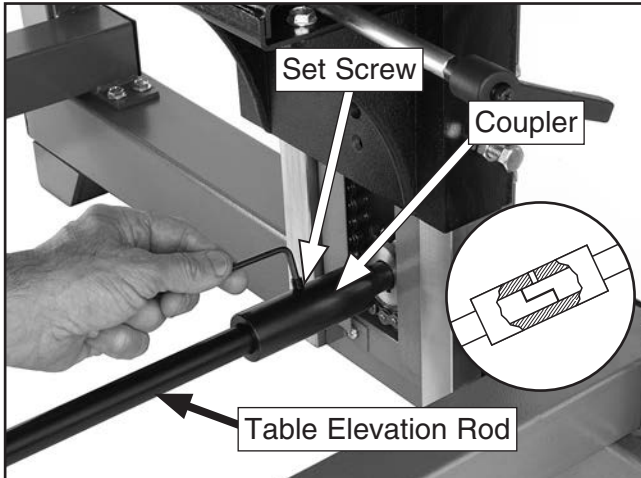

Figure 15. Table elevation rod.

6. With the help of an assistant, place the platen assembly onto the assembled frame, as shown in **Figure 16**.

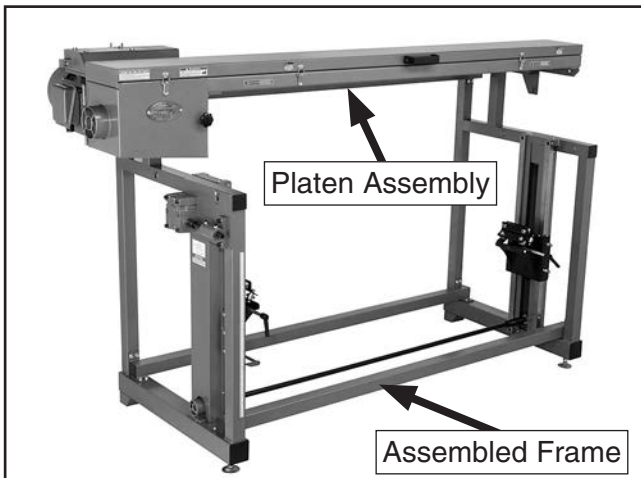

Figure 16. Platen assembly.

7. Secure the motor and platen assembly with the pivot bolts, lock nuts, platen lock knobs, and 1/2" flat washers, as shown in **Figure 17**.

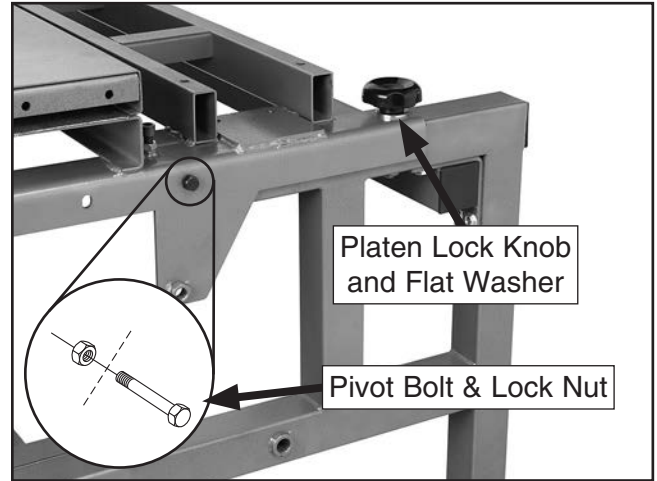

Figure 17. Pivot bolt, nut, and knob.

8. Assemble the lock bracket by placing the bracket over the stud and securing it with the 1/2"-13 lock nut, then inserting the lock handle through the bracket slot and into the threaded hole, as shown in **Figure 18**.

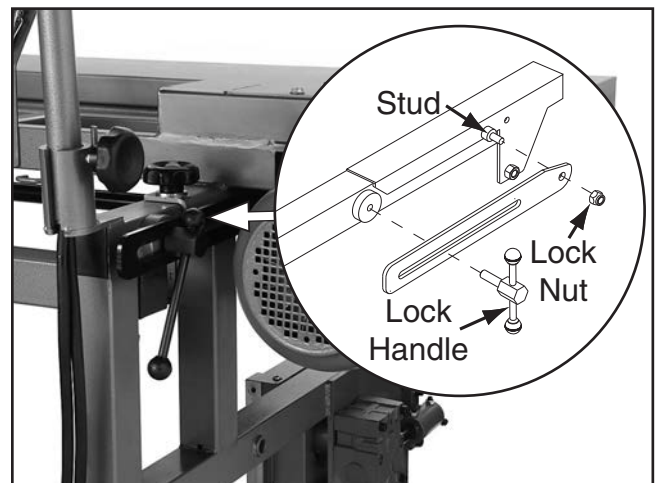

Figure 18. Lock bracket.



9. Attach the two belt cover latch assemblies to the platen assembly frame with (4) $\frac{1}{4}$ -20 x $\frac{1}{2}$ flange bolts, as shown in **Figure 19**.

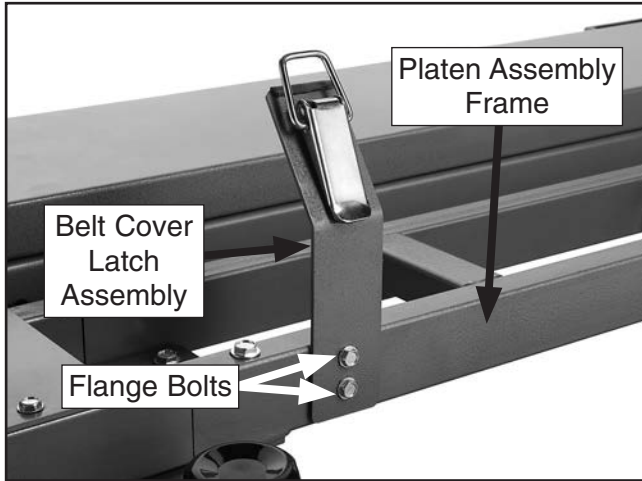

Figure 19. Lid latches.

10. Connect the idler wheel assembly to the platen assembly frame with (4) $\frac{5}{16}$ -18 x $\frac{1}{2}$ flange bolts, as shown in **Figure 20**.

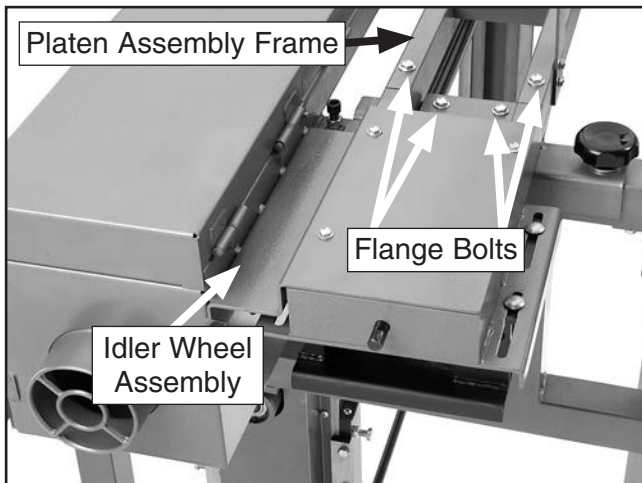

Figure 20. Idler wheel assembly.

11. Secure the idler wheel box to the platen assembly with (2) $\frac{5}{16}$ -18 x $\frac{1}{2}$ flange bolts and $\frac{5}{16}$ -18 hex nuts, as shown in **Figure 21**.

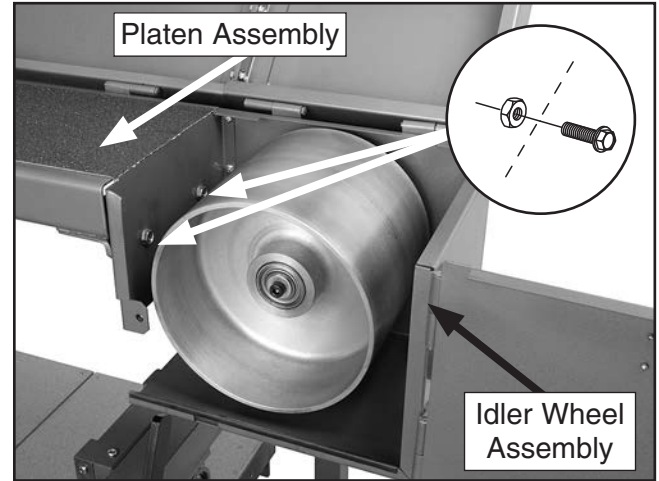

Figure 21. Idler wheel box.

12. Open the platen cover, align it with the idler wheel cover, then secure the two together with (3) $\frac{1}{4}$ -20 x $\frac{1}{2}$ flange bolts and (3) $\frac{1}{4}$ -20 hex nuts, as shown in **Figure 22**. Close and latch the platen cover.



Figure 22. Platen cover connection.



13. Place the switch boom into the switch boom socket and secure with the lock knob, as shown in **Figure 23**.

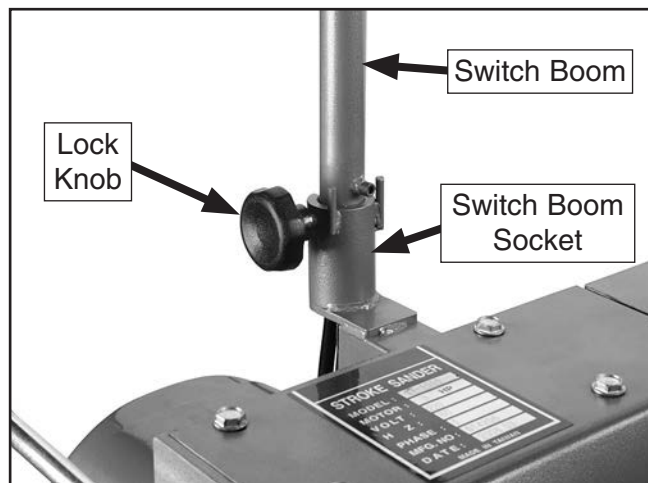

Figure 23. Switch boom.

14. Slide the two table rails into the table bearing assemblies on both sides of the frame (**Figure 24**).

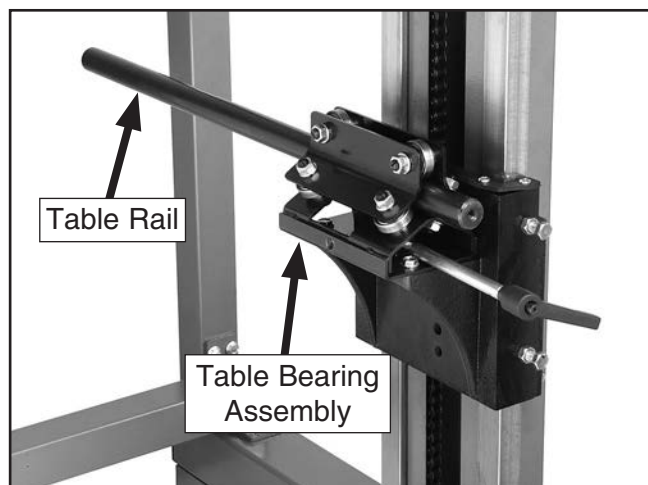

Figure 24. Table rails.

15. With the help of an assistant, place the table over the table rails and secure it with the (4) $\frac{5}{16}$ -18 x $\frac{3}{4}$ " cap screws and $\frac{5}{16}$ " flat washers (**Figure 25**).

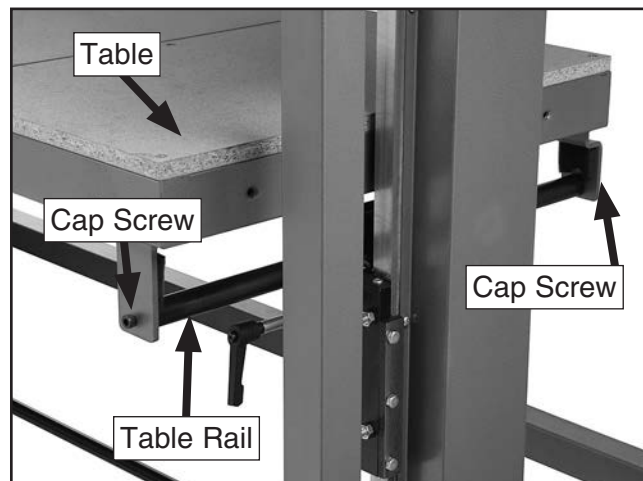

Figure 25. Table mounting.

16. Attach the rear cover to the left and right uprights with the (6) $\frac{1}{4}$ -20 x $\frac{1}{2}$ " Phillips head screws, as shown in **Figure 26**.

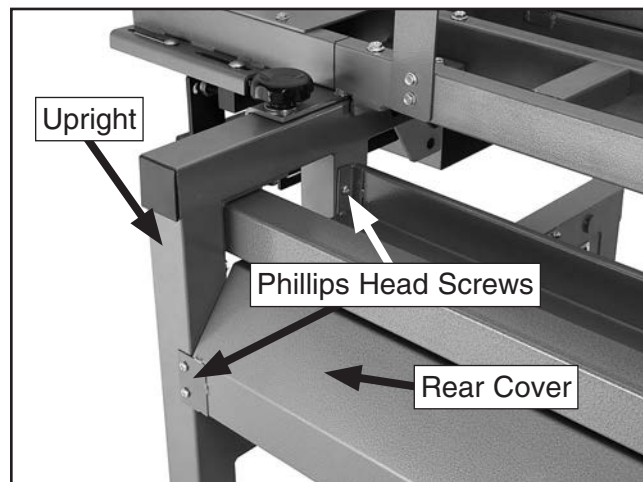

Figure 26. Rear cover.



17. Attach the platen press rail assembly to the left and right uprights with the (4) $\frac{1}{4}$ -20 x $\frac{1}{2}$ " cap screws, as shown in **Figure 27**.

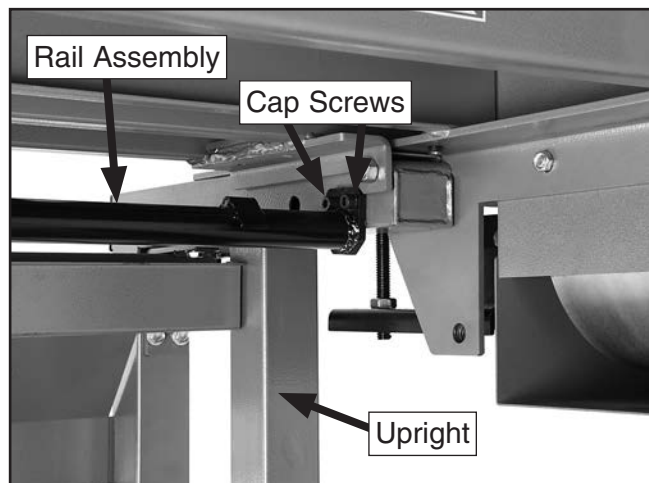

Figure 27. Platen press rail assembly.

18. Insert the platen press assembly and the platen press counterweight into the platen press slide, then tighten the lock lever and cap screw, as shown in **Figure 28**.

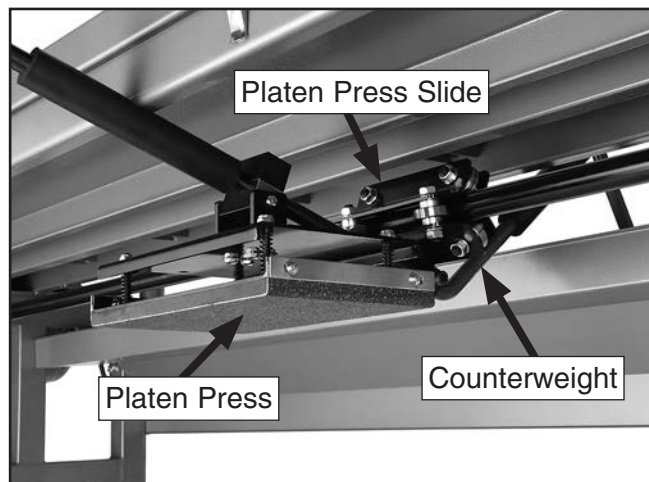

Figure 28. Platen press and counterweight.

19. Slide the larger handwheel on the elevation control shaft and the smaller handwheel on the belt tension shaft, then secure each by tightening the set screws and lock nuts (**Figure 29**).



Figure 29. Handwheel Attachment.

20. Attach the table stop with (2) $\frac{5}{16}$ -18 x $\frac{1}{2}$ flange bolts (**Figure 30**).

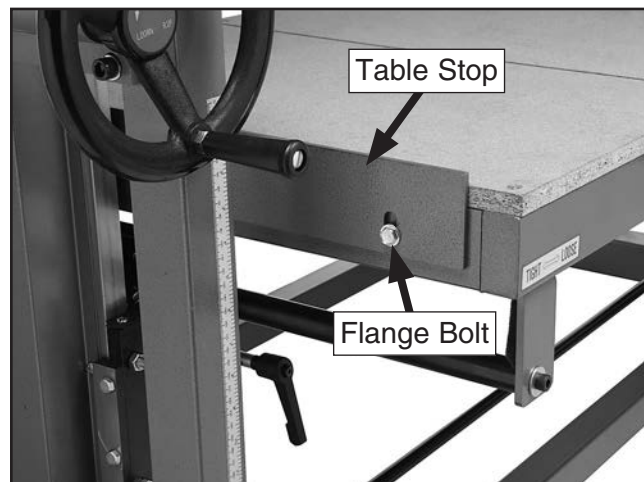

Figure 30. Table stop attachment.



21. Attach the auxiliary workstop rods by threading the workstop rods into the machine base, then sliding the workstops over the rods and tightening the knobs. (**Figure 31**).

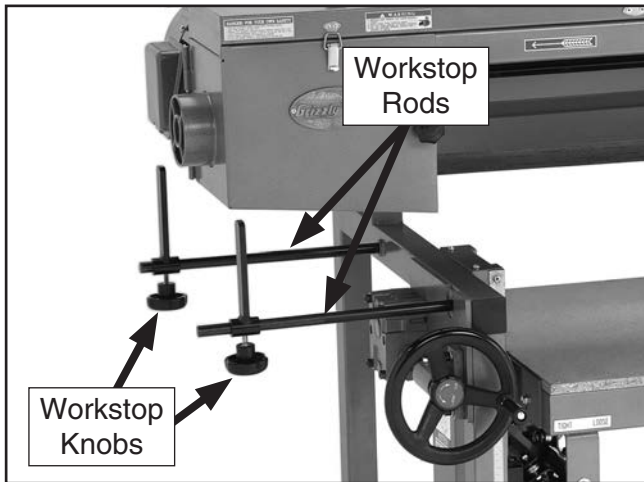

Figure 31. Auxiliary workstops.

22. Thread the belt tilt lever into the platen assembly, as shown in **Figure 32**.

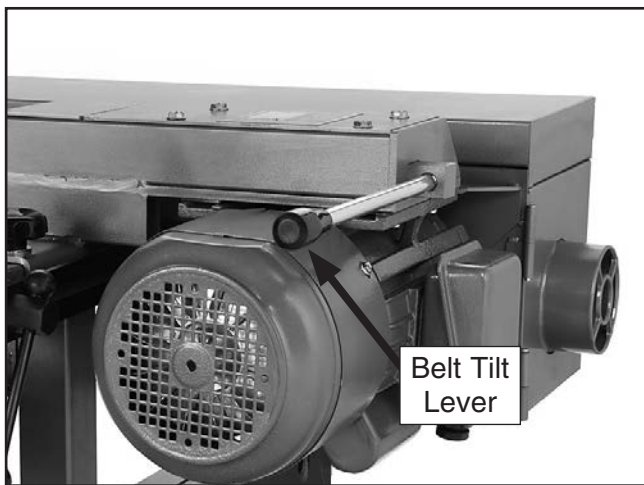

Figure 32. Belt tilt lever.

Machine Leveling

Once assembly is complete, move your machine into position, then level it. Use a level to check from side-to-side and front-to-back.

To adjust for level from side-to-side, use shims under the rear feet of the machine.

To level from front-to-back, use the leveling feet. Thread each foot in or out as necessary, then tighten the jam nut to secure it in position (**Figure 33**).

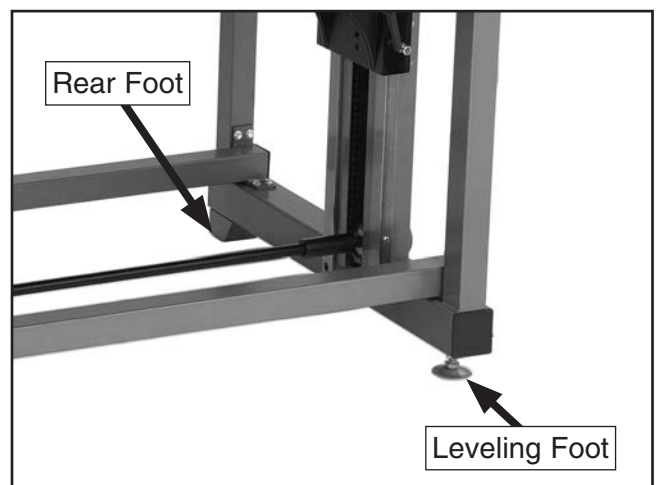

Figure 33. Machine leveling.



Dust Collection

CAUTION

DO NOT operate the Model G0679 without an adequate dust collection system. This sander creates substantial amounts of wood dust while operating. Failure to use a dust collection system can result in short and long-term respiratory illness.

To connect a dust collection hose:

1. Fit the 4" flexible dust hose over the dust ports located at each end of the belt assembly, as shown in **Figure 34**, and secure them in place with hose clamps.

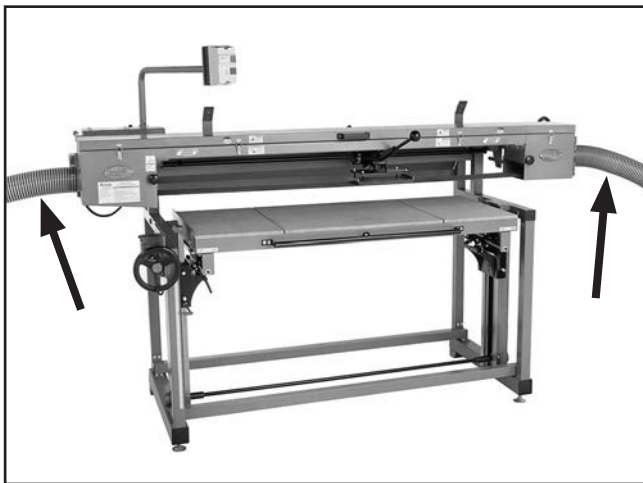

Figure 34. Dust hose attached to dust ports.

2. Tug the hoses to make sure they do not come off. **Note:** A tight fit is necessary for proper performance.

Test Run

Once the assembly is complete, test run your machine to make sure it runs properly.

If, during the test run, you cannot easily locate the source of an unusual noise or vibration, stop using the machine immediately, then review the **Troubleshooting** on **Page 33**.

If you still cannot remedy a problem, contact our Tech Support at (570) 546-9663 for assistance.

To test run the machine:

1. Make sure you have read the safety instructions at the beginning of the manual and that the machine is setup properly.
2. Make sure all tools and objects used during setup are cleared away from the machine.
3. Connect the machine to the power source.
4. Tension the belt so that less than 1/2" of sag is observed along its length.
5. Turn the machine **ON**.
6. Listen and watch for abnormal noises or actions. The machine should run smoothly with little or no vibration or rubbing noises.

—Strange or unusual noises should be investigated and corrected before operating the machine further. Always disconnect the machine from power when investigating or correcting potential problems.

7. Turn the machine **OFF**.



SECTION 4: OPERATIONS

Operation Safety

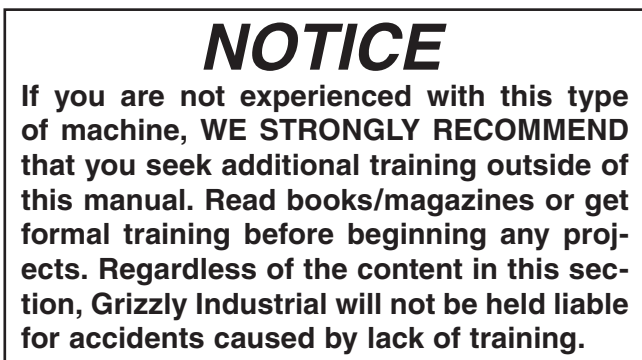
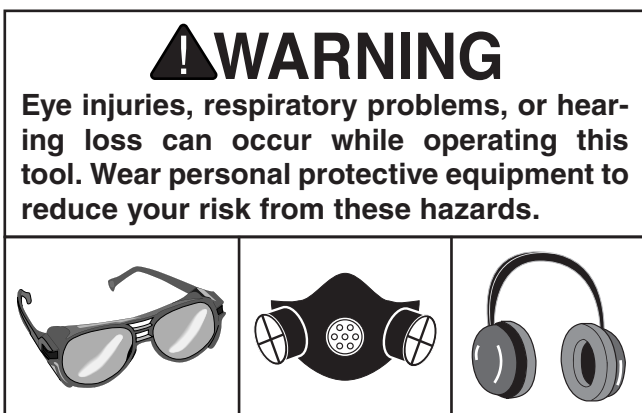

Basic Controls

Use **Figures 35–36** and the descriptions below to become familiar with the basic controls of the machine.

ON/OFF Switch: Turns the Motor ON/OFF.

Table Elevation Handwheel: Raises and lowers the table to allow for different size workpieces.

Table Work Stop: Can be raised to provide workpiece stability and prevent kickback, and can be lowered for larger workpieces.

Auxiliary Work Stops: Used to secure workpieces that are larger than the table.

Table Depth Indicator: Displays the distance between the table surface and the belt.

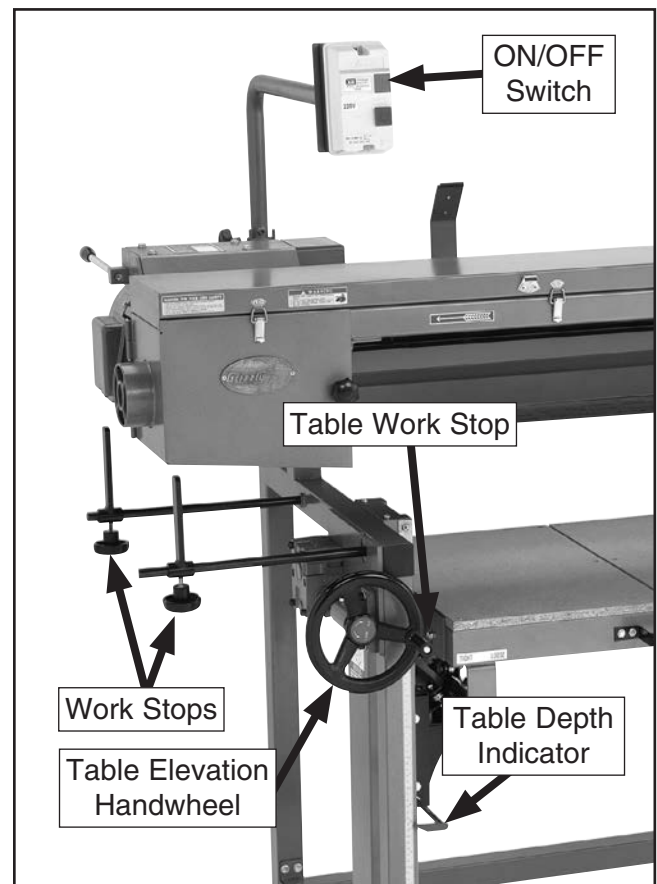

Figure 35. Basic controls.



ON/OFF Switch: Powers the motor, turning the sanding belt.

Belt Tension Handwheel: Adjusts the amount of tension that is placed on the sanding belt.

Platen Press Handle: Used to exert platen pressure through the sanding belt and against the workpiece. Slides along the length of the table to allow complete sanding coverage.

Table Movement Handle: Allows for easy and safe movement of the table forward and backward to provide complete sanding coverage.

Table Travel Lock (right side shown): Locks the horizontal table travel to prevent unwanted movement during use.

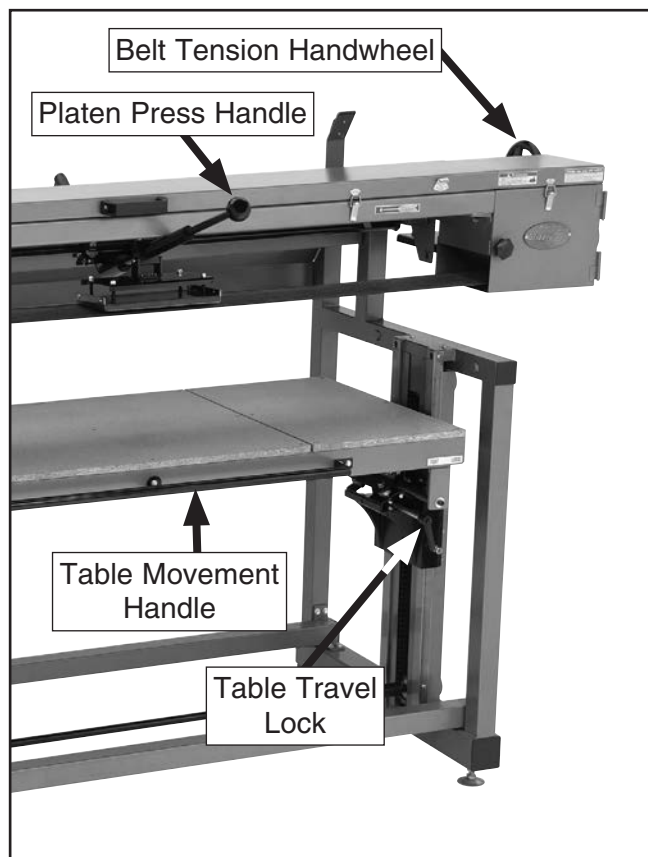

Figure 36. Basic controls (continued).

Table Movement

The table on the Model G0679 can be moved both vertically and horizontally.

Vertical Table Movement

Vertical movement is used to accommodate workpieces of different thicknesses and once set for a specific workpiece, doesn't need to be changed.

1. Place the workpiece on the table.
2. Turn the table elevation handwheel to raise the table until the workpiece is $\frac{1}{4}$ "– $\frac{1}{2}$ " below the sanding belt (**Figure 37**).

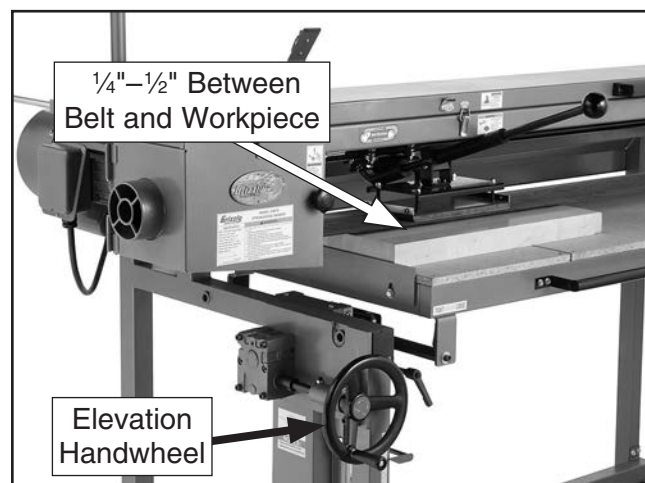

Figure 37. Vertical table movement.

Note: Due to the locking nature of the worm-drive gearbox, no lock is needed to prevent vertical table movement.



Horizontal Table Movement

Horizontal table movement is used together with the platen press movement to allow complete sanding of workpieces with large surface areas. Horizontal table movement can be locked when table movement is not desired.

1. Make sure the horizontal table travel locks are released by rotating them counterclockwise until the table moves freely (**Figure 38**).

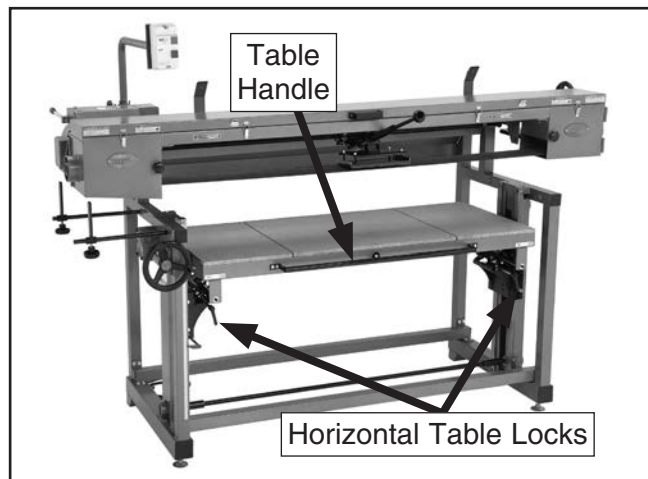

Figure 38. Horizontal table movement.

2. Push or pull the table handle to move the table forward and backward.

Note: To lock the horizontal table movement, turn the table travel locks $\frac{1}{8}$ of a turn clockwise. To release the horizontal table movement, turn the table travel locks $\frac{1}{8}$ of a turn counterclockwise. Be careful not to over-tighten the lock handles. Doing so may cause damage to the machine.

Workstops

The Model G0679 is equipped with two workstop mechanisms. The table workstop is used on workpieces that fit entirely on the table and the auxiliary workstops are used on workpieces that are larger than the table.

Make sure the workstops are positioned to secure the workpiece against the direction of the belt.

- When the sander is in the stroke sanding mode, the workstops must be placed on the left side of the machine.
- When the sander is in edge sanding mode, the work stops must be placed on the right side of the machine.

!WARNING

The belt speed on the Model G0679 is 3600 FPM, or over 40 MPH. A workpiece ejected at this speed could cause serious personal injury and property damage. Always use the workstops and be sure they are in the correct position and secured before using the machine.

Table Workstop

1. Loosen the flange bolts that hold the workstop to the table (**Figure 39**).

—If the workstop must be repositioned to the other side of the machine, remove the flange bolts completely and relocate the work stop as needed, then re-thread the flange bolts into the appropriate holes.

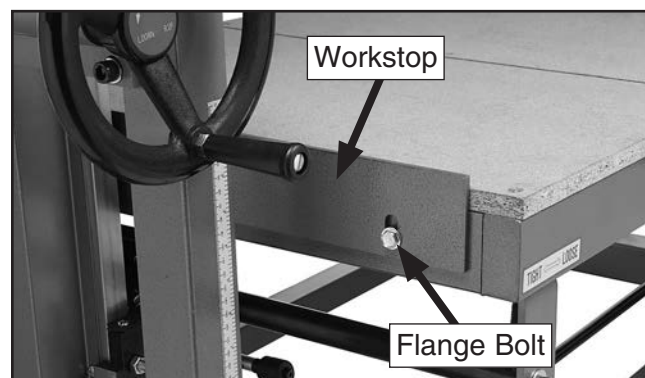

Figure 39. Table workstop.



- Slide the workstop up as far as it will go. It will extend approximately $\frac{3}{8}$ " above the surface of the table, providing a lip for the workpiece to rest against during use.
- To lower the table workstop, loosen the flange bolts that hold the workstop to the table, lower the work stop so that it is below the surface of the table, then tighten the flange bolts to prevent them from rattling loose during use.

Auxiliary Workstops

- Loosen the workstop knobs, rotate the workstops so the knob is facing down, then position the workstops in the location needed to properly support the workpiece (**Figure 40**).

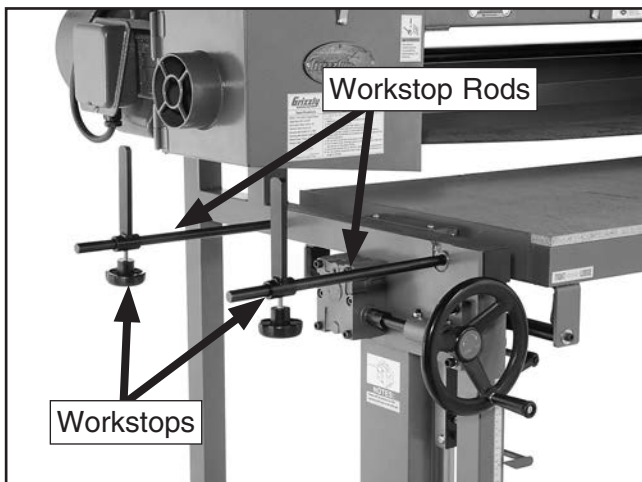

Figure 40. Auxiliary workstops.

—If the workstops must be repositioned to the other side of the machine, un-thread and remove the workstop rods from the machine base and re-thread them into the other side of the machine before positioning the workstops.

- Tighten the work knobs.

Stroke/Edge Sander Conversion

For maximum versatility, the Model G0679 functions both as a stroke sander and an edge sander. Conversion from one to the other takes only a few minutes and requires removing the platen press and counterweight, pivoting the belt assembly, adjusting the table position, and relocating the workstops.

To convert the machine from stroke sander to edge sander:

- DISCONNECT SANDER FROM POWER!
- Lower the table until the indicator reads 7" or greater to provide adequate clearance for tilting the belt assembly.
- Slide the platen press assembly all the way to the left and lift the counterweight over the small hook located on the rear of the machine to secure it in place. Remove the platen press by loosening the handle that secures it in place.
- Release the belt cover latches to open the belt cover, then secure it in the open position using the two latches shown in **Figure 41**.

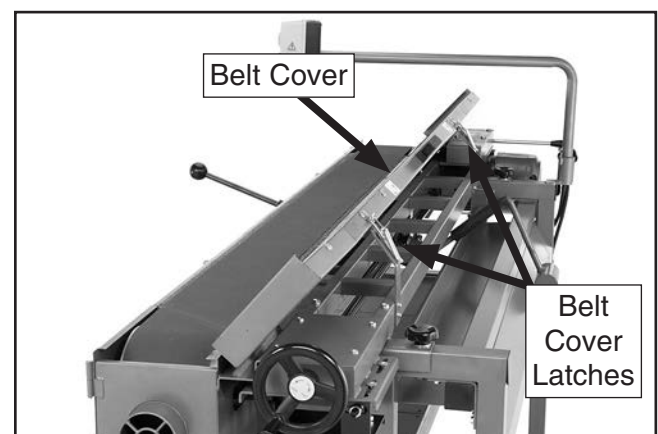

Figure 41. Belt cover latched open.

- Remove the auxiliary workstops from the machine base and the table workstop from the table.
- Make sure the belt pulley access doors are closed and secured.



7. Loosen the belt tilt lock handle and remove the two belt tilt lock knobs (**Figure 42**).

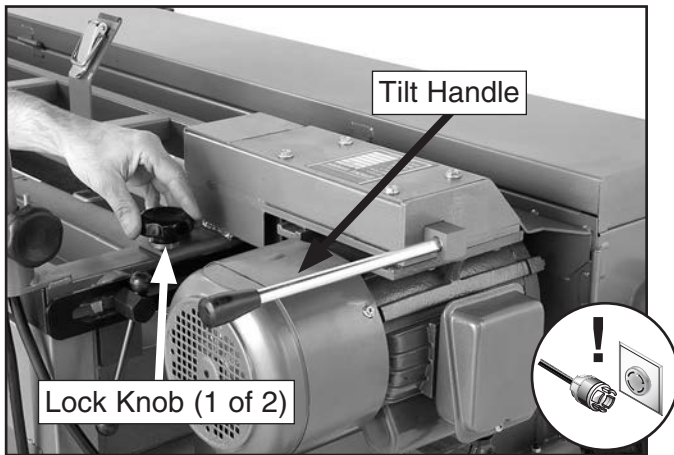

Figure 42. Tilt lock handle and lock knobs.

8. Use the belt tilt handle to tilt the entire belt assembly (**Figure 43**).

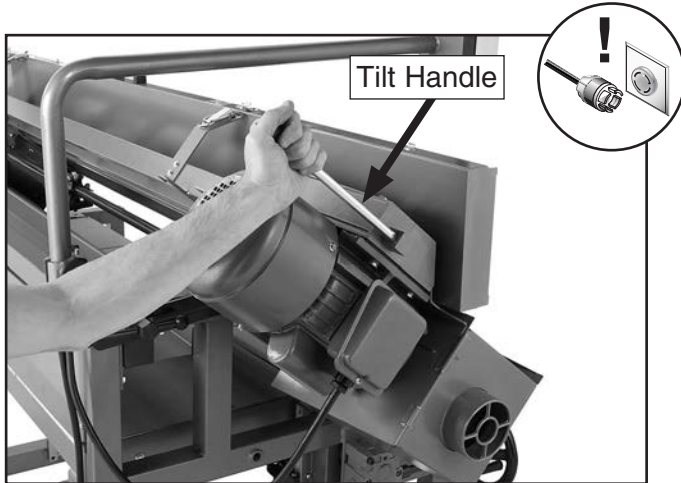

Figure 43. Tilting belt assembly.

9. Replace the belt tilt lock knobs into the edge sanding position (**Figure 44**).

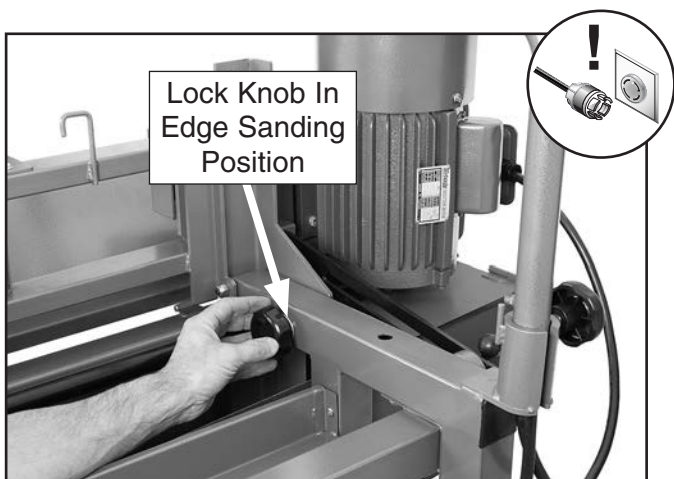

Figure 44. Lock knobs in edge sanding position.

10. Pull the table all the way forward, lock it in place with the table travel locks, then use the table elevation handwheel to raise the table until it is even with the belt (**Figure 45**).

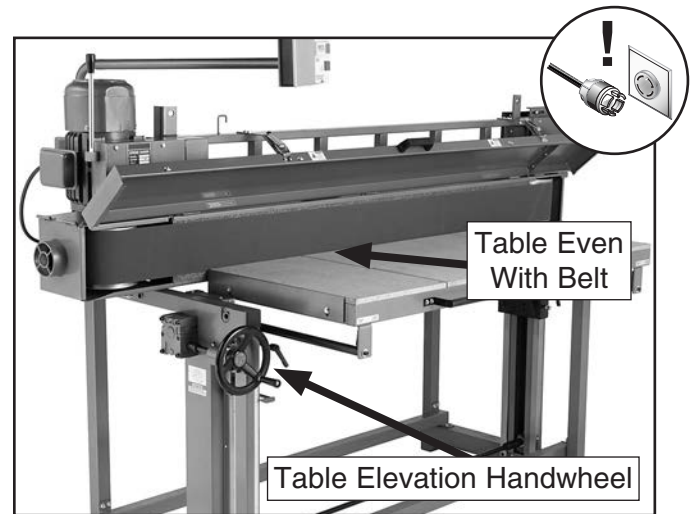

Figure 45. Elevating table.

NOTICE

If you try to raise the table to the top edge of the belt, the table and belt assembly will bind and may damage the machine. Do not attempt to force the table above the midline of the belt.

11. Position the table workstop on the right side of the table and the auxiliary work stops on the right side of the base.



Belt Replacement

Replacing the sanding belt on the Model G0679 is a simple process and is performed when the sanding belt becomes worn or when a sanding belt of a different grit is desired.

To replace the sanding belt:

1. DISCONNECT SANDER FROM POWER!
2. Use the belt tension handwheel to release tension from the belt.
3. Open the belt cover, drive wheel cover, and idler wheel cover (**Figure 46**).

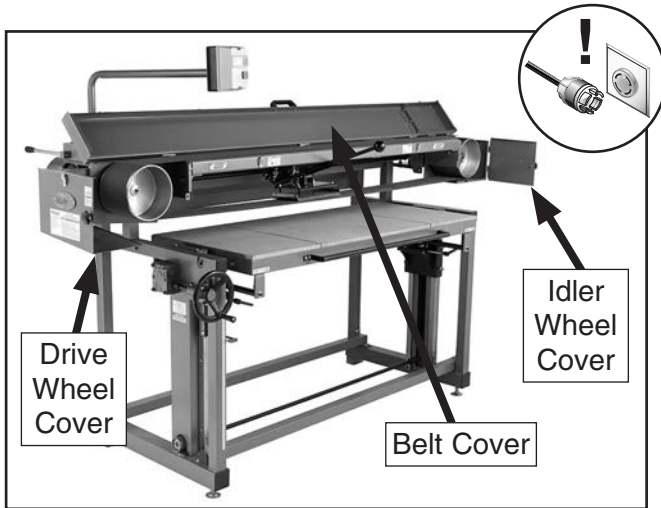

Figure 46. Belt covers open.

4. Slide the belt off of one of the wheels first, then remove the belt entirely.
5. Place the new sanding belt over one of the wheels, making sure the belt direction is correct.

6. Place the belt along the top platen, under the platen press, and over the other wheel, as shown in **Figure 47**.

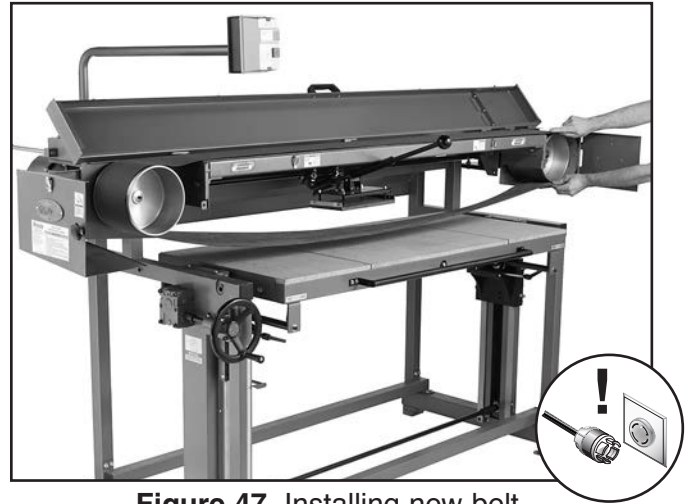

Figure 47. Installing new belt.

7. Center the belt over both wheels, then close the drive wheel and idler wheel covers.
8. Tension the belt so that the belt sags less than 1/2" across its length, then check the belt tracking, as described in **Belt Tracking** on **Page 36**.



Platen Press Movement

A stroke sander is unique in that it uses a movable platen to apply sanding pressure to the workpiece. This allows a user to vary the amount of material removed over different areas of the workpiece.

The platen press moves in two different planes. Movement in the vertical plane allows for variations in the amount of pressure applied while movement in the horizontal plane allows the user to sand different areas of the workpiece. This horizontal movement, combined with the horizontal movement of the table allows the entire surface of large workpieces to be sanded (**Figures 48**).

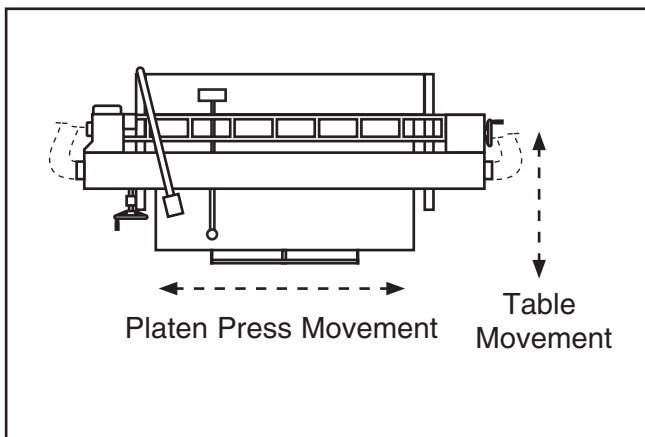

Figure 48. Sanding movements.

To move the platen press:

1. Pull the platen press handle down to apply pressure to the workpiece.
2. Slide the platen press handle side-to-side to move the platen press along the length of the workpiece.

To move the table:

1. Grasp the table handle.
2. Slide the table horizontally to move the workpiece across the width of the sanding belt.

Basic Operations

Stroke Sander

1. Place the workpiece on the table and against the table workstop.

—If the workpiece is larger than the table, raise the table so that the workpiece hangs over the edge of the table above the uprights and against the auxiliary workstops.
2. Make sure the workstops are secure and that they will not move during operation.
3. Tension the sanding belt.
4. Raise the table until the workpiece is approximately $\frac{1}{4}$ "– $\frac{1}{2}$ " below the surface of the sanding belt.
5. Turn the machine **ON**.
6. Grasp the platen press handle and pull it downward to apply sanding pressure to the workpiece. Move the platen press along the length of the workpiece. If your workpiece is wider than the width of the belt, use the table handle to move the table horizontally to sand across the width of the workpiece.
7. When the sanding is completed, turn the machine **OFF**.

Edge Sander

1. Convert the machine to the edge sander mode. Make sure the table workstop and auxiliary workstops are positioned on the right side of the machine.
2. Place the workpiece on the table, against either the table workstop or the auxiliary workstops.
3. Turn the machine **ON**.
4. Keeping the workpiece secure against the workstop, feed it towards the sanding belt.
5. When the sanding is completed, turn the machine **OFF**.



SECTION 5: ACCESSORIES

Basic Eye Protection

- T20501—Face Shield Crown Protector 4"
- T20502—Face Shield Crown Protector 7"
- T20503—Face Shield Window
- T20451—"Kirova" Clear Safety Glasses
- T20452—"Kirova" Anti-Reflective S. Glasses
- T20456—DAKURA Safety Glasses, Black/Clear



Figure 49. Our most popular eye protection.

H2443—Universal Adapter

This seven step adapter provides a multitude of dust collection reducing options. Simply cut away unneeded steps with a hacksaw. Outside diameter step sizes include 1", 2", 2.5", 3", 4", 5", and 6". Wall thickness is 1/8".

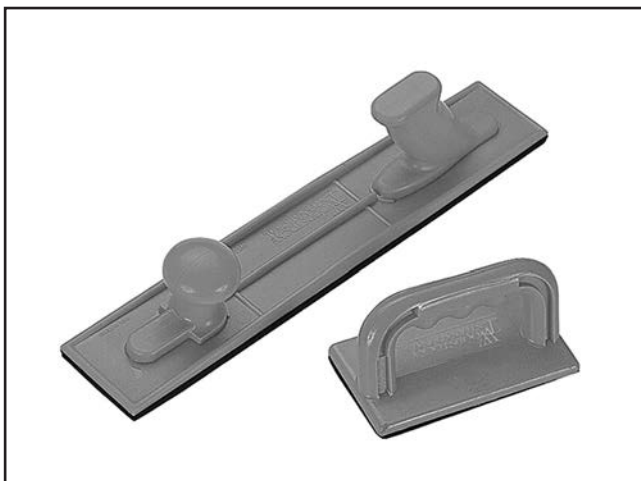

Figure 50. H2443 Universal Adapter.

PRO-STICK® Abrasive Surface Cleaners

Extend the life of your sanding discs and sleeves! Choose the Pro-Stick® with a handle for greater control or without a handle for more usable area.

Size	Model
1½" X 1½" X 8½"	G1511
2" X 2" X 12"	G1512
1½" X 1½" X 9" with Handle	G2519
2" X 2" X 11" with Handle	G2520



Figure 51. PRO-STICK® abrasive cleaners.

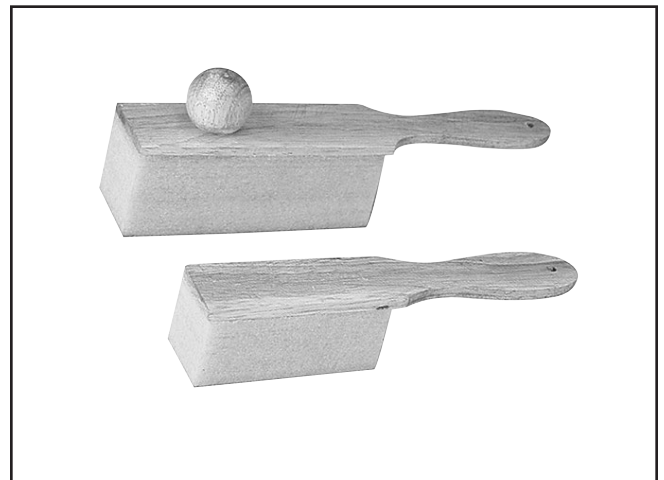

Figure 52. PRO-STICK® cleaners with handles.

order online at www.grizzly.com or call 1-800-523-4777



- G5443—6" x 186"; 60 Grit
- G5444—6" x 186"; 80 Grit
- G5445—6" x 186"; 100 Grit
- G5446—6" x 186"; 120 Grit
- G5447—6" x 186"; 150 Grit
- G5548—6" x 186"; 180 Grit
- G5549—6" x 186"; 220 Grit

These high quality "J" weight cloth-backed belts last longer and sand smoother!

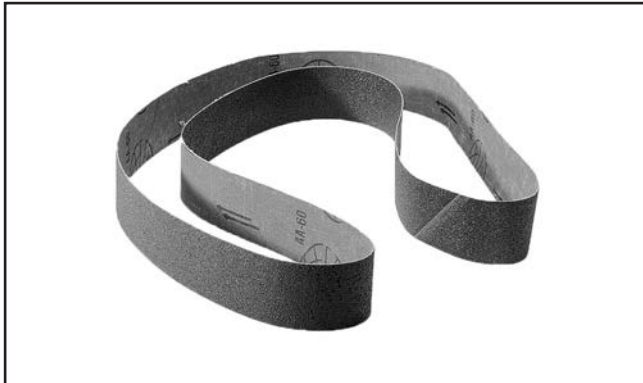

Figure 53. Replacement sanding belts.

- H2499—Small Half-Mask Respirator
- H3631—Medium Half-Mask Respirator
- H3632—Large Half-Mask Respirator
- H3635—Cartridge Filter Pair P100

Wood dust has been linked to nasal cancer and severe respiratory illnesses. If you work around-dust everyday, a half-mask respirator can be a lifesaver. Also compatible with safety glasses!



Figure 54. Half-mask respirator with disposable cartridge filters.

- G2752—4" Rolling Floor Sweep
 - G2753—4" Bench Dust Collection Attachment
 - G2754—4" Floor Dust Collection Attachment
- These attachments are indispensable for collecting excess dust. The rolling floor sweep is also a convenient way to keep the shop floor or work-bench top clean! Designed for use with 4" flexible hose (not included).

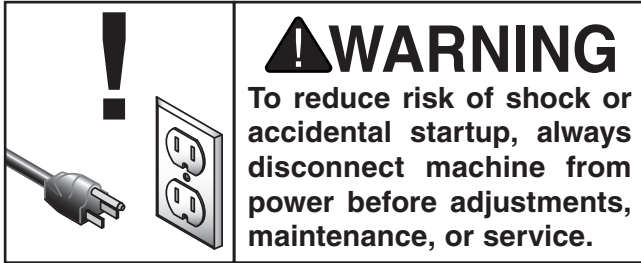

Figure 55. Dust collection attachments.

order online at www.grizzly.com or call 1-800-523-4777



SECTION 6: MAINTENANCE



Schedule

For optimum performance from your machine, follow this maintenance schedule and refer to any specific instructions given in this section.

Daily Check:

- Loose mounting bolts.
- Worn or damaged sanding belt.
- Worn or damaged wires.
- Any other unsafe condition.

Weekly Maintenance:

- Grease table elevation ways.
- Grease belt tension leadscrew.
- Oil table elevation chain.
- Clean/grease hold down shaft.

Every 500 Hours:

- Refill table elevation gearbox.

Cleaning

Cleaning the Model G0679 is relatively easy. Vacuum sawdust, and wipe off the remaining dust with a dry cloth. If any resin has built up, use a resin dissolving cleaner to remove it.

Lubrication

Lubrication for the Model G0679 consists of greasing the table elevation ways, and belt tension leadscrew, oiling the table elevation chain, and refilling the table elevation gearbox.

Table Elevation Ways

Clean the table elevation ways with mineral spirits and a rag or brush to remove any grime. Dry the ways, then brush on a thin coat of light multi-purpose grease. Use the table elevation handwheel to move the table up and down several times to disperse the grease (**Figure 56**).

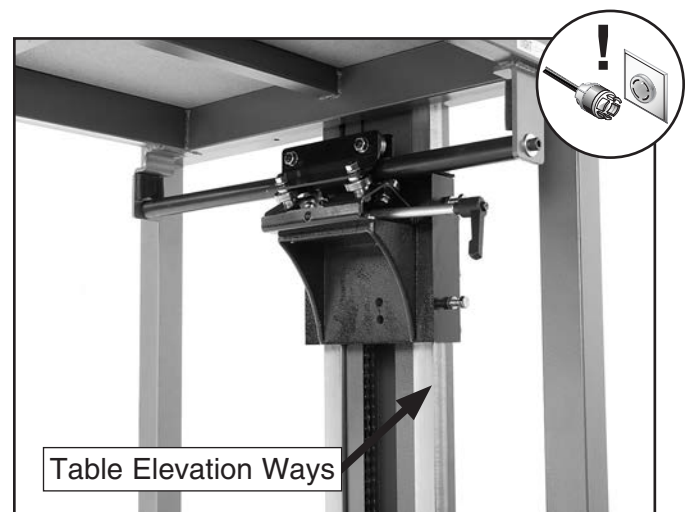

Figure 56. Table elevation ways.



Belt Tension Leadscrew

Clean the belt tension leadscrew with mineral spirits and a rag or brush to remove any grime. Dry the leadscrew, then brush on a thin coat of light multi-purpose grease. Use the belt tension handwheel to tighten and loosen the belt several times to disperse the grease (**Figure 57**).

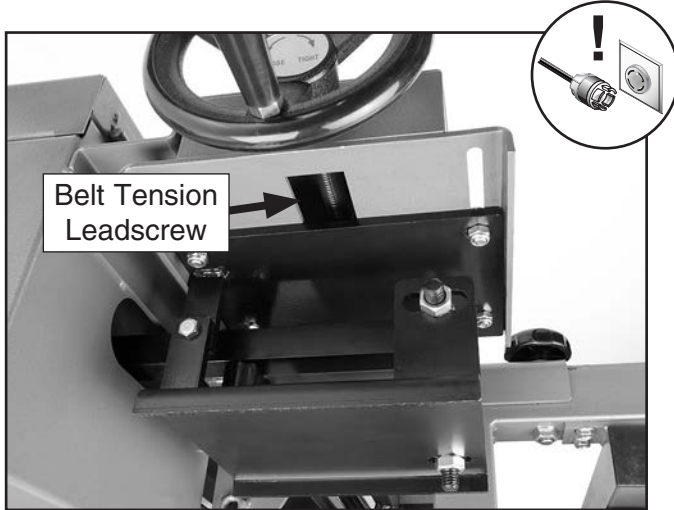

Figure 57. Belt tension leadscrew.

Table Elevation Gearbox

After every 500 hours of use, the table elevation gearbox must be refilled. Use a rag to clean any grime from around the filler plug, then remove the filler plug and use a manual oiler to add oil until the gearbox is full. Replace the filler plug (**Figure 58**).

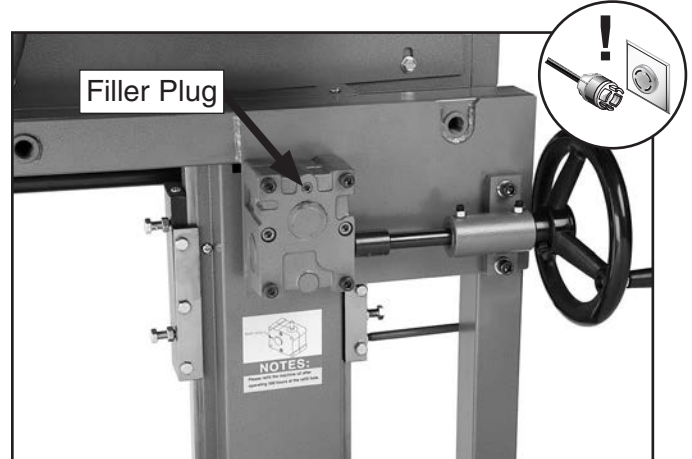

Figure 58. Table elevation gearbox.

Table Elevation Chain

Clean the table elevation chain with mineral spirits and a rag or brush to remove any grime. To ensure complete cleaning of the chain, raise and lower the table to expose the entire length of chain. Dry the chain, then spray on a chain lubricant. Raise and lower the table several times to disperse the lubricant (**Figure 57**).

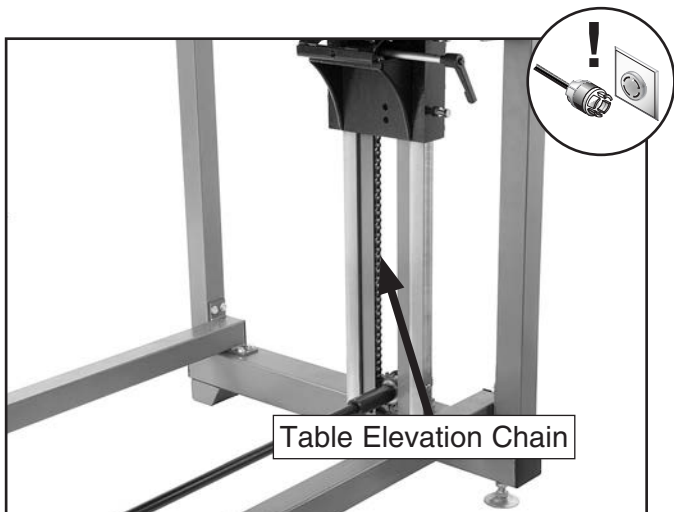

Figure 57. Table elevation chain.



SECTION 7: SERVICE

Review the troubleshooting and procedures in this section if a problem develops with your machine. If you need replacement parts or additional help with a procedure, call our Technical Support. **Note:** *Please gather the serial number and manufacture date of your machine before calling.*

Troubleshooting

Motor & Electrical

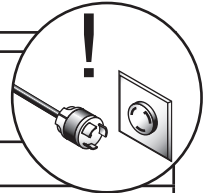

Symptom	Possible Cause	Possible Solution
Machine does not start or a breaker trips.	<ol style="list-style-type: none"> 1. Power supply switched OFF or is at fault. 2. Start capacitor is at fault. 3. Motor connection wired incorrectly. 4. Wall fuse/circuit breaker is blown/tripped. 5. Wiring is open/has high resistance. 6. Motor ON/OFF switch is at fault. 	<ol style="list-style-type: none"> 1. Ensure power supply is switched on; ensure power supply has the correct voltage. 2. Test/replace if faulty. 3. Correct motor wiring connections (Page 38). 4. Ensure circuit size is suitable for this machine; replace weak breaker. 5. Check for broken wires or disconnected/corroded connections, and repair/replace as necessary. 6. Replace faulty ON/OFF switch.
Machine stalls or is overloaded.	<ol style="list-style-type: none"> 1. Motor connection is wired incorrectly. 2. Motor bearings are at fault. 3. Motor has overheated. 4. Motor is at fault. 	<ol style="list-style-type: none"> 1. Correct motor wiring connections (Page 38). 2. Test by rotating shaft; rotational grinding/loose shaft requires bearing replacement. 3. Clean off motor, let cool, and reduce workload. 4. Test/repair/replace.
Machine has vibration or noisy operation.	<ol style="list-style-type: none"> 1. Motor or component is loose. 2. Motor mount loose/broken/incorrect. 3. Motor fan is rubbing on fan cover. 4. Motor bearings are at fault. 	<ol style="list-style-type: none"> 1. Inspect/replace stripped or damaged bolts/nuts, and re-tighten with thread locking fluid. 2. Tighten/replace/adjust. 3. Replace dented fan cover; replace loose/damaged fan. 4. Test by rotating shaft; rotational grinding/loose shaft requires bearing replacement.



Operations

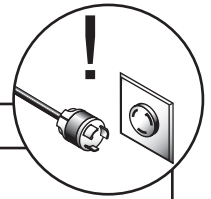

Symptom	Possible Cause	Possible Solution
Machine vibrates excessively (non-motor related).	<ol style="list-style-type: none"> 1. Stand not stable on floor. 2. Incorrect sanding belt tension. 3. Broken/defective sanding belt. 	<ol style="list-style-type: none"> 1. Level machine. 2. Make sure tension is correct (Page 27). 3. Replace sanding belt (Page 27).
Sanded surface not square.	<ol style="list-style-type: none"> 1. Table not perpendicular to belt. 	<ol style="list-style-type: none"> 1. Adjust 90° stop (Page 35).
Deep sanding grooves or scores in workpiece.	<ol style="list-style-type: none"> 1. Sandpaper too coarse for the desired finish. 2. Workpiece sanded across the grain. 3. Too much sanding force on workpiece. 4. Workpiece held still against the belt. 	<ol style="list-style-type: none"> 1. Use a finer grit sanding belt. 2. Sand with the grain. 3. Reduce pressure on workpiece while sanding. 4. Keep workpiece moving while sanding on the belt.
Abrasive grit rubs off the belt easily.	<ol style="list-style-type: none"> 1. Sanding belt has been stored in an incorrect environment. 2. Sanding belt has been folded or smashed. 	<ol style="list-style-type: none"> 1. Store sanding belt away from extremely dry/hot or damp/wet temperatures. 2. Store sanding belt flat, not folded or bent.
Sanding belt surface clogs quickly or burn.	<ol style="list-style-type: none"> 1. Too much pressure applied to workpiece. 2. Sanding softwood. 3. Sanding belt grit too fine. 	<ol style="list-style-type: none"> 1. Reduce pressure on workpiece while sanding. 2. Use different stock. Or, accept the characteristics of the stock and plan on cleaning/replacing belts frequently. 3. Use coarser grit sanding belt.
Burn marks on workpiece.	<ol style="list-style-type: none"> 1. Using too fine of sanding grit. 2. Using too much pressure. 3. Platen press/workpiece held still for too long. 	<ol style="list-style-type: none"> 1. Use a coarser grit sanding belt. 2. Reduce pressure on workpiece while sanding. 3. Do not keep platen press/workpiece in one place for too long.
Glazed sanding surfaces.	<ol style="list-style-type: none"> 1. Sanding wet stock. 2. Sanding stock with high residue. 	<ol style="list-style-type: none"> 1. Dry stock properly before sanding. 2. Use different stock. Or, accept the characteristics of the stock and plan on cleaning/replacing belts frequently.
Belt rubs on machine frame.	<ol style="list-style-type: none"> 1. Tracking incorrect. 	<ol style="list-style-type: none"> 1. Adjust belt tracking (Page 36).



Table Bearings

The table rolls forward and backwards on bearing assemblies. If you notice excessive vertical play in the table, you may need to adjust the bearing assemblies.

The bearings are mounted on eccentric shafts. By rotating the shaft, the position of the bearings is moved up or down. To remove excessive play, it is only necessary to adjust the top two bearings on each side of the table.

Tools Needed	Qty
Wrench 14mm	1
Standard Screwdriver	1

To adjust the bearing assemblies:

1. Loosen the hex nuts on each end of the bearing shafts. It is not necessary to fully remove them (**Figure 59**).

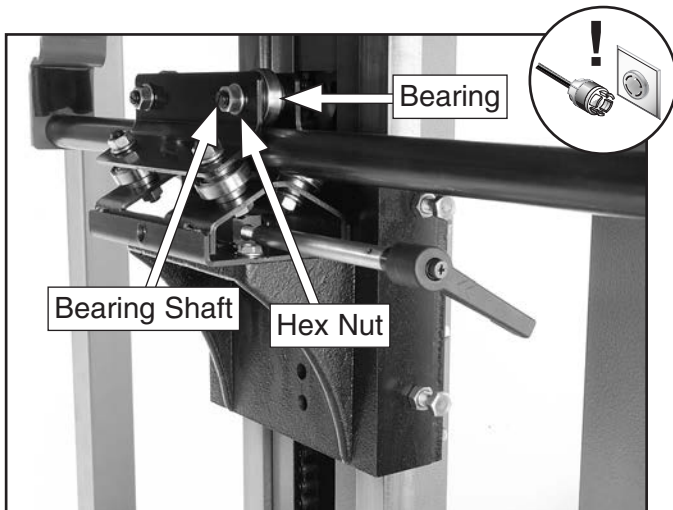

Figure 59. Table bearing adjustment.

2. Use a standard screwdriver to rotate the bearing shaft. You will see the bearing moving inward or outward relative to the table rod. Rotate the shaft so that the bearing is snug against the table rod.
3. Without rotating the shaft, tighten the hex nuts.
4. Repeat **Steps 1–3** for the other three bearing shafts.

90° Stop

The Model G0679 is equipped with an adjustable 90° stop to ensure that the belt is perpendicular to the table when converted to the edge sanding mode. If the belt is not 90° to the table, this stop can be adjusted.

To adjust the 90° stop:

1. DISCONNECT SANDER FROM POWER!
2. Convert the sander to the edge sanding mode, if it is not already.
3. Use a square to check the angle between the belt and the table at both ends of the machine (**Figure 60**).

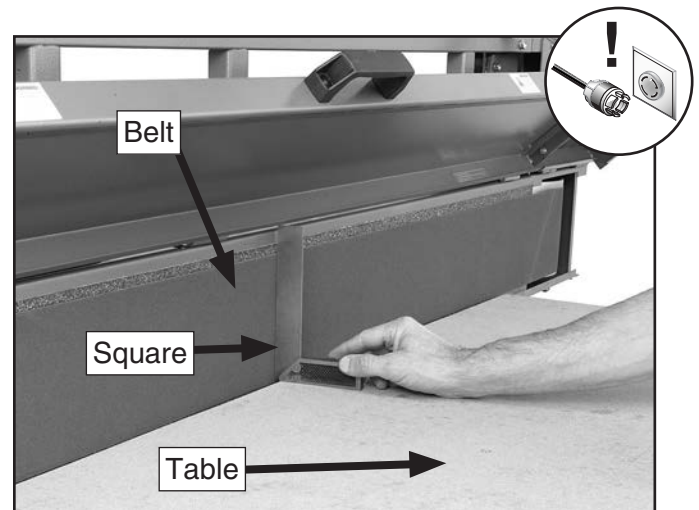

Figure 60. Checking belt for square.

- If the belt is square at both ends, no adjustment is needed.
- If the belt is not square at both ends, proceed with these instructions.



- Lower the belt cover, as shown in **Figure 61**, to gain access to the 90° stop screws. Loosen the jam nut several turns so that the cap screw can turn freely.

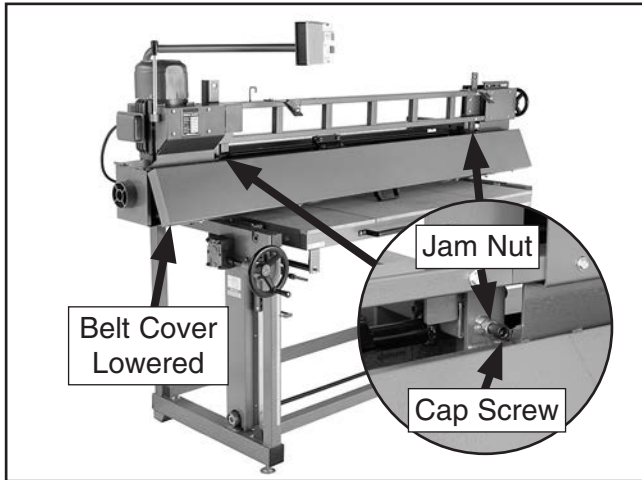

Figure 61. Jam nut and cap screw.

- Adjust the cap screw as needed until the belt is square to the table. Lift the belt cover as needed to access the belt surface.
- Without turning the cap screw, tighten the jam nut.
- Repeat **Steps 4–6** on the other 90° stop.
- Re-check for square, and repeat **Steps 4–7**, as necessary until the setting meets your standards.

Belt Tracking

The sanding belt tracking on the Model G0679 can be adjusted to make sure the belt travels smoothly between the drive and idler wheels without rubbing on the sides of the platen assembly.

Tools Needed	Qty
Safety Glasses	1 Pair
Wrench 19mm	1

To adjust the sanding belt tracking:

- Open the belt cover.
- Loosen the outer belt tracking nut (**Figure 62**)

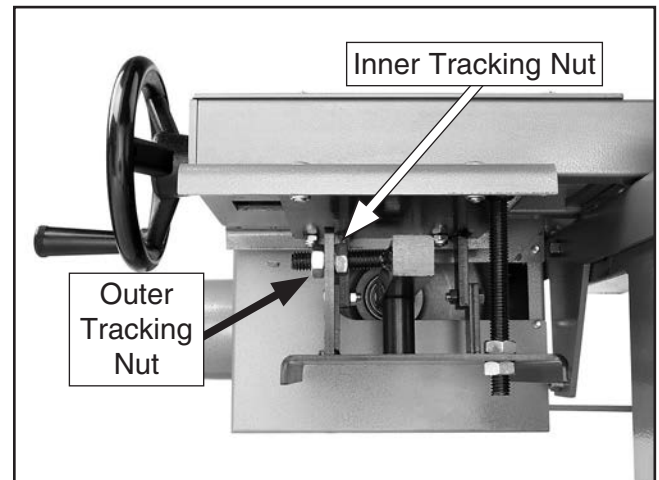

Figure 62. Belt tracking adjustment.

- While wearing safety glasses, turn the sander **ON**.
- Turn the inner nut as needed until the belt is centered on the drive and idler wheels, then tighten the outer nut.
- Make sure the belt is still tracking properly.
 - If the belt is tracking properly, no further adjustment is needed.
 - If the belt is no longer tracking properly, repeat **Steps 4–5** until the tracking is correct.
- Turn the sander **OFF**.



Table Elevation Wear Pin Adjustment

The table travels vertically along the table elevation ways. A series of wear pins reduce friction between the table brackets and elevation ways, making it easier to move the table up and down. Over time, these pins will wear, resulting in slop between the table brackets and elevation ways. To compensate for this wear, the wear pins can be adjusted.

Tools Needed	Qty
Wrench 14mm	1

To adjust the wear pins:

1. DISCONNECT SANDER FROM POWER!
2. Loosen the jam nut shown in (Figure 63).

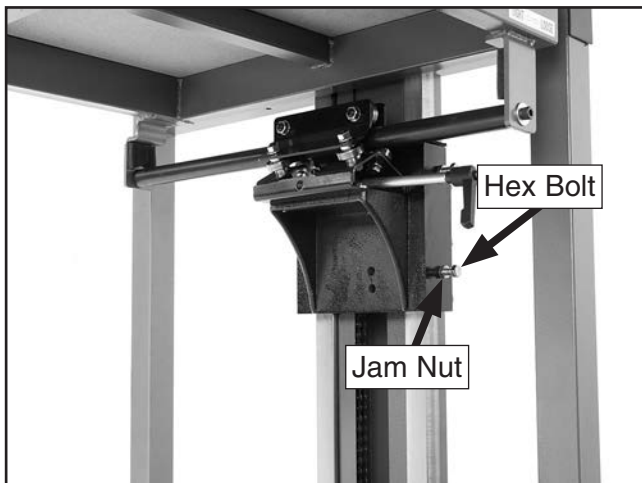

Figure 63. Wear pin adjustment.

3. Tighten the hex bolt until you just begin to feel resistance.
—The goal is to position the wear pins against the ways without applying pressure to the them. The ideal setting will allow easy, slop-free horizontal movement of the table.
4. When you are satisfied with the positioning of the hex bolt, keep it from turning and fully tighten the jam nut.
5. Repeat **Steps 2–4** with the remaining seven wear pins.



SECTION 8: WIRING

These pages are current at the time of printing. However, in the spirit of improvement, we may make changes to the electrical systems of future machines. Compare the manufacture date of your machine to the one stated in this manual, and study this section carefully.

If there are differences between your machine and what is shown in this section, call Technical Support at (570) 546-9663 for assistance BEFORE making any changes to the wiring on your machine. An updated wiring diagram may be available. **Note:** *Please gather the serial number and manufacture date of your machine before calling. This information can be found on the main machine label.*

WARNING

Wiring Safety Instructions

SHOCK HAZARD. Working on wiring that is connected to a power source is extremely dangerous. Touching electrified parts will result in personal injury including but not limited to severe burns, electrocution, or death. Disconnect the power from the machine before servicing electrical components!

MODIFICATIONS. Modifying the wiring beyond what is shown in the diagram may lead to unpredictable results, including serious injury or fire. This includes the installation of unapproved after-market parts.

WIRE CONNECTIONS. All connections must be tight to prevent wires from loosening during machine operation. Double-check all wires disconnected or connected during any wiring task to ensure tight connections.

CIRCUIT REQUIREMENTS. You MUST follow the requirements at the beginning of this manual when connecting your machine to a power source.

WIRE/COMPONENT DAMAGE. Damaged wires or components increase the risk of serious personal injury, fire, or machine damage. If you notice that any wires or components are damaged while performing a wiring task, replace those wires or components.

MOTOR WIRING. The motor wiring shown in these diagrams is current at the time of printing but may not match your machine. If you find this to be the case, use the wiring diagram inside the motor junction box.















CAPACITORS/INVERTERS. Some capacitors and power inverters store an electrical charge for up to 10 minutes after being disconnected from the power source. To reduce the risk of being shocked, wait at least this long before working on capacitors.

EXPERIENCING DIFFICULTIES. If you are experiencing difficulties understanding the information included in this section, contact our Technical Support at (570) 546-9663.

NOTICE

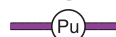
The photos and diagrams included in this section are best viewed in color. You can view these pages in color at www.grizzly.com.

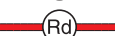
COLOR KEY

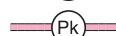
BLACK 	BLUE 	YELLOW 	LIGHT BLUE 
WHITE 	BROWN 	YELLOW GREEN 	BLUE WHITE 
GREEN 	GRAY 	PURPLE 	TURQUOISE 
RED 	ORANGE 	PINK 	



Wiring Diagram

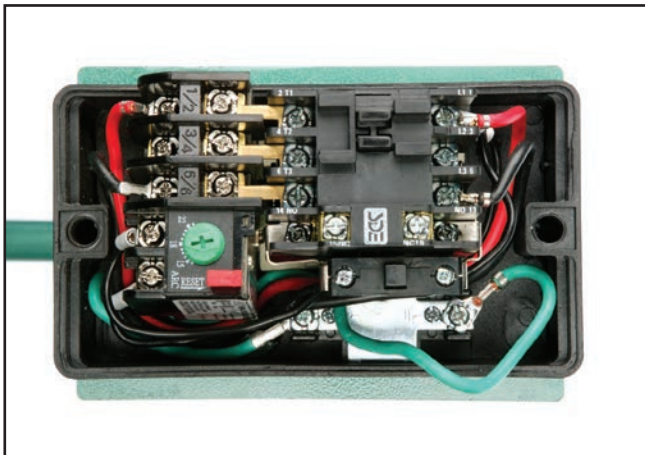
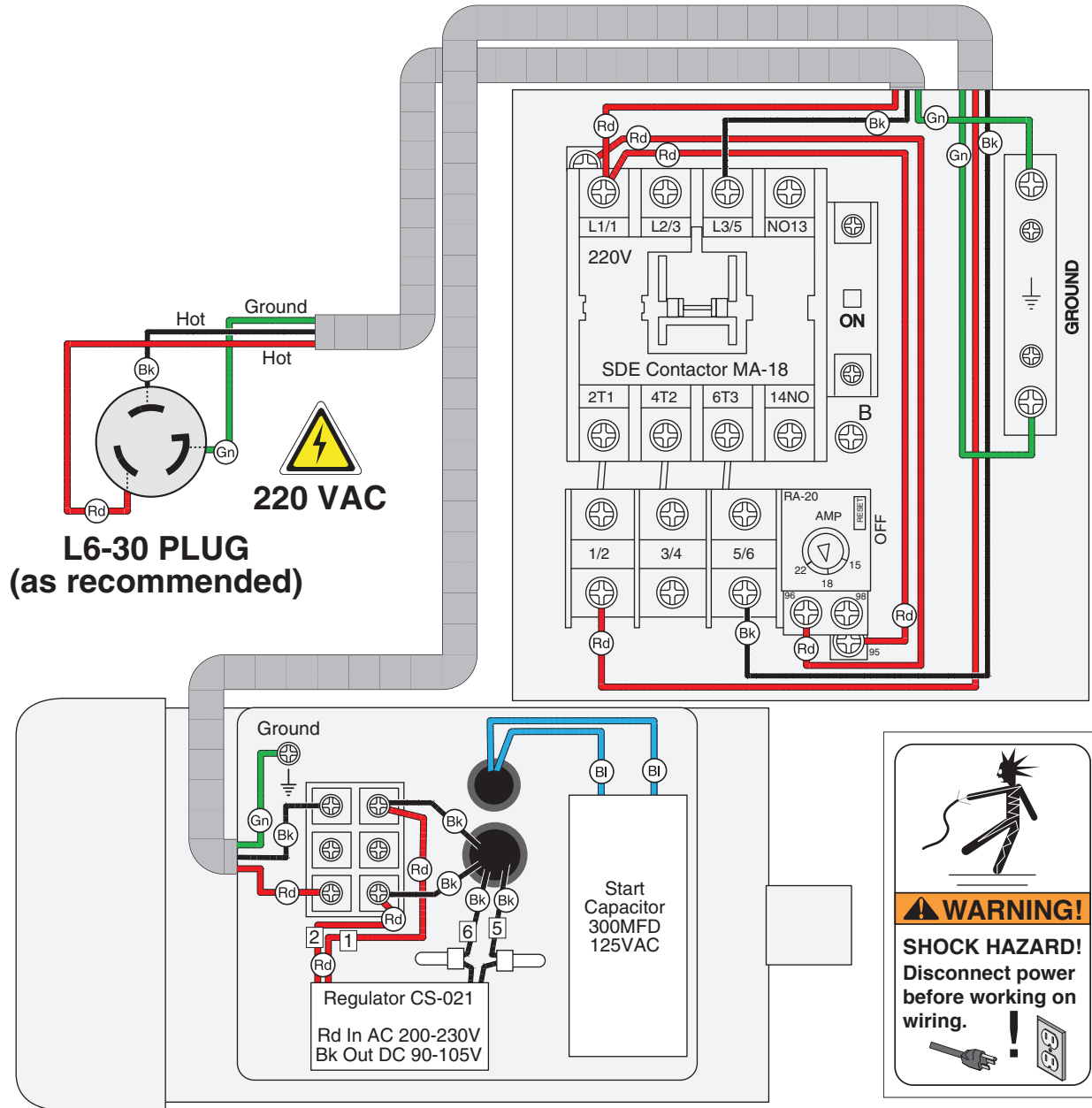

Figure 64. Switch wiring.

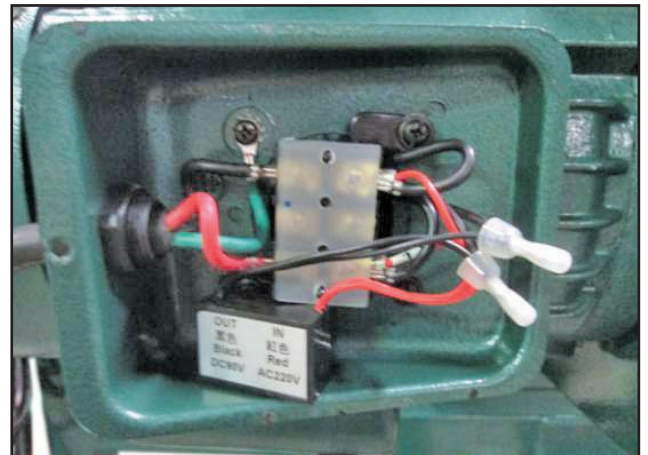
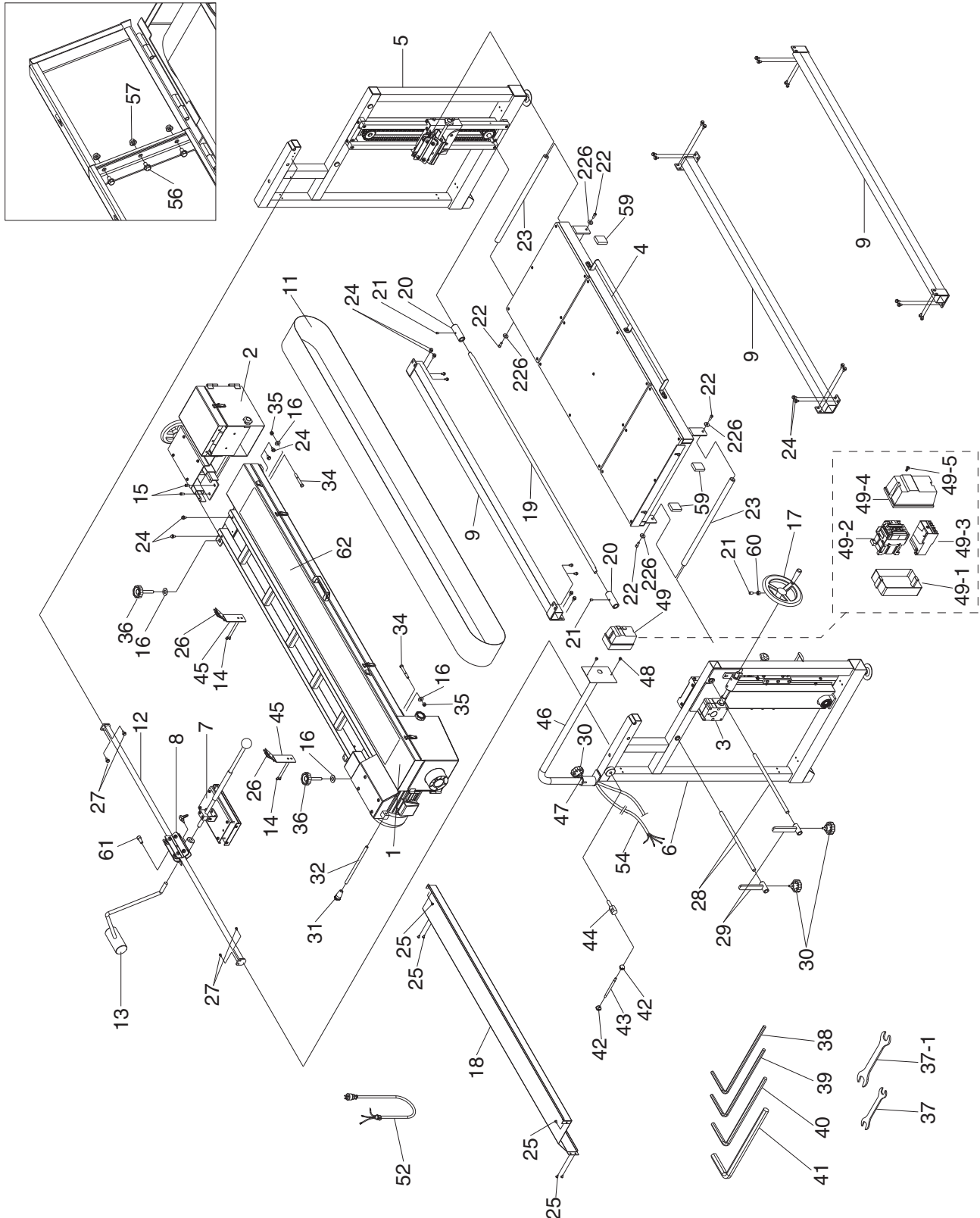

Figure 65. Motor wiring.



SECTION 9: PARTS

Main Breakdown



Main Parts List

REF	PART #	DESCRIPTION
1	P0679001	BELT PLATE ASSEMBLY
2	P0679002	FRONT BELT PLATE ASSEMBLY
3	P0679003	GEAR BOX ASSEMBLY
4	P0679004	TABLE ASSEMBLY
5	P0679005	RIGHT UPRIGHT ASSEMBLY
6	P0679006	LEFT UPRIGHT ASSEMBLY
7	P0679007	PLATEN ASSEMBLY
8	P0679008	PLATEN PRESS ASSEMBLY
9	P0679009	CONNECTING TUBE
10	P0679010	PHLP HD SCR 10-24 X 3/8
11	P0679011	SANDING BELT 100 GRIT
12	P0679012	PLATEN ASSEMBLY ROD
13	P0679013	COUNTERWEIGHT
14	P0679014	FLANGE BOLT 1/4-20 X 1/2
15	P0679015	FLANGE BOLT 5/16-18 X 1/2
16	P0679016	FLAT WASHER 1/2
17	P0679017	HANDWHEEL
18	P0679018	COVER
19	P0679019	CHAIN CONNECTING ROD
20	P0679020	CONNECTING ROD CAP
21	P0679021	SET SCREW 5/16-18 X 5/16
22	P0679022	CAP SCREW 5/16-18 X 3/4
23	P0679023	TABLE SPINDLE
24	P0679024	FLANGE BOLT 5/16-18 X 1/2
25	P0679025	PHLP HD SCR 1/4-20 X 3/8
26	P0679026	BELT COVER CLAMP
27	P0679027	HEX BOLT 1/4-20 X 1/2
28	P0679028	COVER SPINDLE
29	P0679029	TUBE CAP
30	P0679030	KNOB 5/16-18 X 3/4
31	P0679031	LEVER KNOB 1/2-12
32	P0679032	LEVER

REF	PART #	DESCRIPTION
34	P0679034	SHOULDER SCREW 1/2-13 X 3
35	P0679035	LOCK NUT 1/2-13
36	P0679036	LOCK KNOB 1/2-12 X 2-3/4
37	P0679037	COMBO WRENCH 12/14MM
37-1	P0679037-1	WRENCH 17 X 19
38	P0679038	HEX WRENCH 4MM
39	P0679039	HEX WRENCH 5MM
40	P0679040	HEX WRENCH 6MM
41	P0679041	HEX WRENCH 8MM
42	P0679042	BALL HANDLE 1/2-12
43	P0679043	ROD
44	P0679044	ANGLE SPINDLE
45	P0679045	COVER FIXING PLATE
46	P0679046	SWITCH SUPPORT
47	P0679047	CAP SCREW 1/4-20 X 1/2
48	P0679048	PHLP HD SCR 10-24 X 3/4
49	P0679049	MAGNETIC SWITCH 3HP 220V 1-PH
49-1	P0679049-1	SWITCH BASE
49-2	P0679049-2	CONTACTOR SDE MA-18
49-3	P0679049-3	OVERLOAD RELAY RA-20
49-4	P0679049-4	SWITCH COVER
49-5	P0679049-5	PLASTIC SCREW
51	P0679051	HEX NUT 10-24
52	P0679052	MOTOR CORD
54	P0679054	POWER CORD
56	P0679056	FLANGE BOLT 1/4-20 X 1/2
57	P0679057	HEX NUT 1/4"-20
59	P0679059	FOAM PAD
60	P0679060	HEX NUT 5/16"-18
61	P0679061	CAP SCREW 5/16-18 X 3/4
62	P0679062	GRAPHITE PAD
226	P0679226	FLAT WASHER 5/16



Belt & Idler Wheel Assembly Breakdown

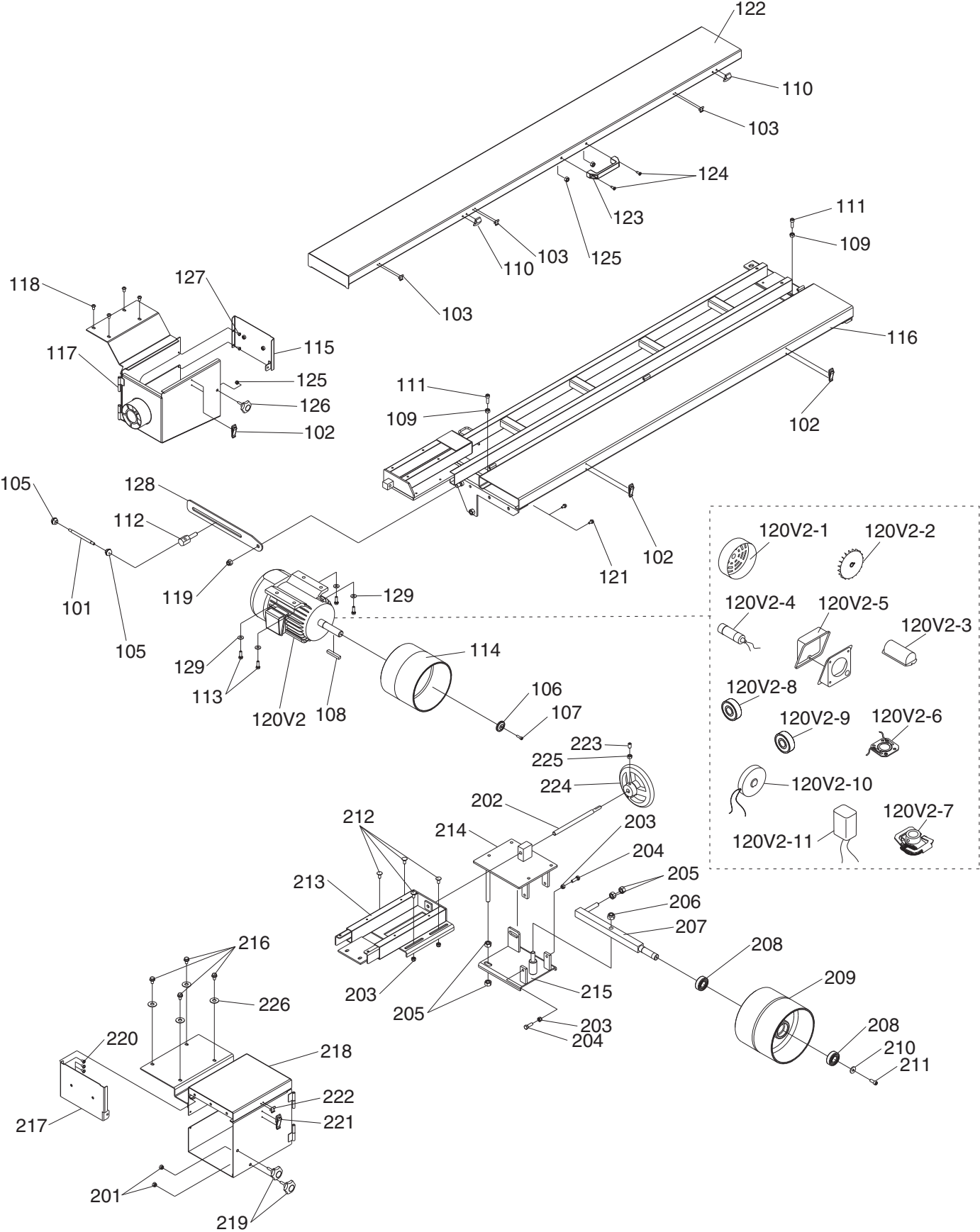

Belt Assembly Parts List

REF	PART #	DESCRIPTION
101	P0679101	BAR
102	P0679102	CLAMP (SMALL)
103	P0679103	HOOK (SMALL)
105	P0679105	BALL HANDLE
106	P0679106	FLANGE WASHER
107	P0679107	CAP SCREW M6-1 X 20
108	P0679108	KEY 7 X 7 X 75
109	P0679109	HEX NUT 3/8-16
110	P0679110	HOOK (BIG)
111	P0679111	CAP SCREW 3/8-16 X 1-1/4
112	P0679112	CONNECTOR 1/2-12 X 1-3/4
113	P0679113	HEX BOLT 5/16-18 X 1
114	P0679114	DRIVING WHEEL
115	P0679115	LEFT COVER BOARD
116	P0679116	BELT PLATE
117	P0679117	DRIVING WHEEL COVER
118	P0679118	PHLP HD SCR 5/16-18 X 1/2
119	P0679119	LOCK NUT 1/2-12
120V2	P0679120V2	MOTOR 3HP 220V 1-PH V2.10.11
120V2-1	P0679120V2-1	MOTOR FAN COVER
120V2-2	P0679120V2-2	MOTOR FAN
120V2-3	P0679120V2-3	CAPACITOR COVER
120V2-4	P0679120V2-4	S CAPACITOR 300M 125V 1-3/4 X 3-3/8
120V2-5	P0679120V2-5	MOTOR JUNCTION BOX
120V2-6	P0679120V2-6	CONTACT PLATE
120V2-7	P0679120V2-7	CENTRIFUGAL SWITCH
120V2-8	P0679120V2-8	BALL BEARING 6205-2RS (FRONT)
120V2-9	P0679120V2-9	BALL BEARING 6203-2RS (REAR)
120V2-10	P0679120V2-10	MOTOR BRAKE MCN CB-04-CS
120V2-11	P0679120V2-11	VOLTAGE REGULATOR AC 220V/DC90V
121	P0679121	FLANGE BOLT 5/16-18 X 1/2
122	P0679122	COVER
123	P0679123	HANDLE (BIG)

REF	PART #	DESCRIPTION
124	P0679124	PHLP HD SCR 1/4-20 X 3/4
125	P0679125	LOCK NUT 1/4-20
126	P0679126	KNOB 1/4-20 X 5/8
127	P0679127	PHLP HD SCR 1/4-20 X 3/8
128	P0679128	TILT LOCK BRACKET
129	P0679129	LOCK WASHER 5/16
201	P0679201	LOCK NUT 1/4-20
202	P0679202	ADJUSTABLE SPINDLE
203	P0679203	LOCK NUT 5/16-18
204	P0679204	HEX BOLT 5/16-18 X 1/2
205	P0679205	HEX NUT 1/2"-12
206	P0679206	SPECIAL NUT 1/2-13
207	P0679207	DRIVING WHEEL SPINDLE
208	P0679208	BALL BEARING 6204ZZ
209	P0679209	IDLER WHEEL
210	P0679210	DRUM WASHER
211	P0679211	CAP SCREW 5/16-18 X 3/4
212	P0679212	CARRIAGE BOLT 5/16-18 X 3/4
213	P0679213	FRONT BELT PLATE
214	P0679214	UPPER ADJUSTABLE SET
215	P0679215	LOWER ADJUSTABLE SET
216	P0679216	FLANGE BOLT 1/4-20 X 1/2
217	P0679217	RIGHT COVER
218	P0679218	DRIVING WHEEL COVER
219	P0679219	LOCK KNOB 1/4-20
220	P0679220	PHLP HD SCR 1/4-20 X 3/8
221	P0679221	CLAMP (SMALL)
222	P0679222	HOOK (SMALL)
223	P0679223	SET SCREW 5/16-18 X 1
224	P0679224	HANDWHEEL
225	P0679225	HEX NUT 5/16"-18
226	P0679226	FLAT WASHER 5/16



Gearbox & Table Breakdown & Parts List

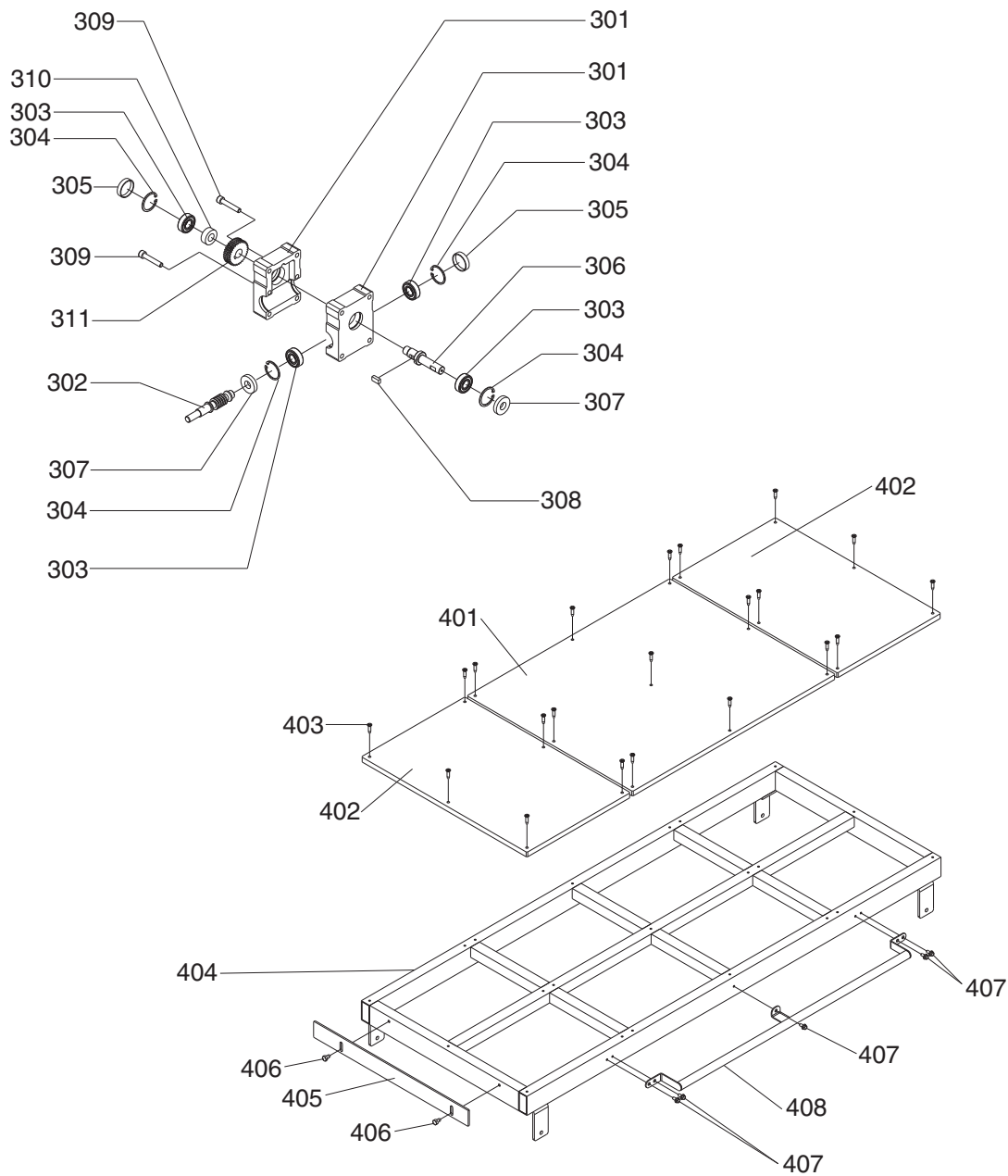

REF	PART #	DESCRIPTION
301	P0679301	GEAR BOX
302	P0679302	WORM SHAFT
303	P0679303	BALL BEARING 6202ZZ
304	P0679304	INT RETAINING RING 35MM
305	P0679305	REAR BUSHING
306	P0679306	GEAR SPINDLE
307	P0679307	FRONT BUSHING
308	P0679308	KEY 7 X 7 X 16
309	P0679309	CAP SCREW 5/16-18 X 1-1/2
310	P0679310	ALUMINUM SPACER

REF	PART #	DESCRIPTION
311	P0679311	WORM GEAR
401	P0679401	WOOD BOARD (LONG)
402	P0679402	WOOD BOARD (SHORT)
403	P0679403	FLAT HD SCR 1/4-20 X 1
404	P0679404	TABLE FRAME
405	P0679405	TABLE WORK STOP
406	P0679406	HEX BOLT 5/16-18 X 1/2
407	P0679407	FLANGE BOLT 1/4-20 X 1/2
408	P0679408	HANDLE (BIG)



Right Upright Assembly Breakdown

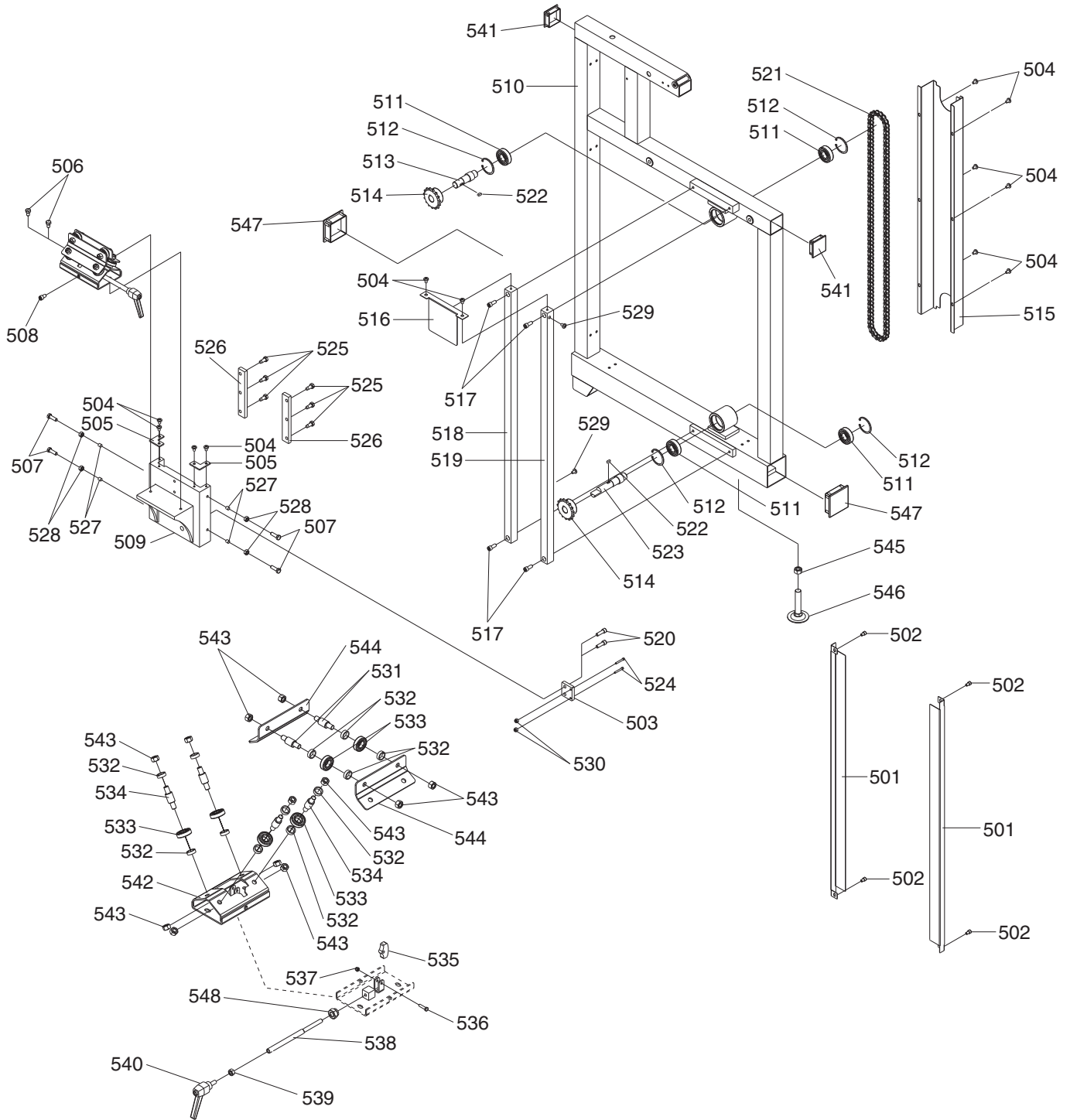

Right Upright Assembly Parts List

REF	PART #	DESCRIPTION
501	P0679501	CHAIN COVER
502	P0679502	CAP SCREW 1/4-20 X 3/8
504	P0679504	PHLP HD SCR 1/4-20 X 3/8
505	P0679505	L-PLATE
506	P0679506	HEX BOLT 5/16-18 X 1/2
507	P0679507	HEX BOLT 5/16-18 X 1
508	P0679508	CAP SCREW 5/16-18 X 1/2
509	P0679509	COVER
510	P0679510	RIGHT SUPPORT FOOT
511	P0679511	BALL BEARING 6240ZZ
512	P0679512	INT RETAINING RING 47MM
513	P0679513	CHAIN WHEEL ADAPTER
514	P0679514	SPROCKET
515	P0679515	CHAIN COVER
516	P0679516	DUST COVER
517	P0679517	CAP SCREW 5/16-18 X 3/4
518	P0679518	GEAR BAR (RIGHT)
519	P0679519	GEAR BAR (LEFT)
520	P0679520	CAP SCREW 5/16-18 X 1
521	P0679521	CHAIN
522	P0679522	KEY 5 X 5 X 10
523	P0679523	CHAIN TRANSMITTING SPINDLE
524	P0679524	CAP SCREW #8-32 X 1
525	P0679525	HEX BOLT 5/16-18 X 3/4

REF	PART #	DESCRIPTION
526	P0679526	TRACKING BOARD
527	P0679527	COPPER WEAR PIN
528	P0679528	HEX NUT 5/16"-18
529	P0679529	PHLP HD SCR 1/4-20 X 1/4
530	P0679530	LOCK NUT #8-32
531	P0679531	ECCENTRIC SPACER
532	P0679532	CAP
533	P0679533	BALL BEARING 6002ZZ
534	P0679534	ADAPTER
535	P0679535	SPINDLE FIXING BOARD
536	P0679536	SPECIAL BOLT M5-.8 X 20
537	P0679537	FLANGE NUT M5-.8
538	P0679538	ADJUSTABLE LOCKING ROD
539	P0679539	HEX NUT M8-1.25
540	P0679540	LOCK HANDLE M4-.7 X 13
541	P0679541	SQUARE CAP
542	P0679542	TRACKING SET (RIGHT)
543	P0679543	HEX NUT 3/8-16
544	P0679544	BRACKET
545	P0679545	HEX NUT 1/2"-12
546	P0679546	FOOT PAD
547	P0679547	CAP
548	P0679548	LOCK NUT 5/16-18



Left Upright Assembly Breakdown

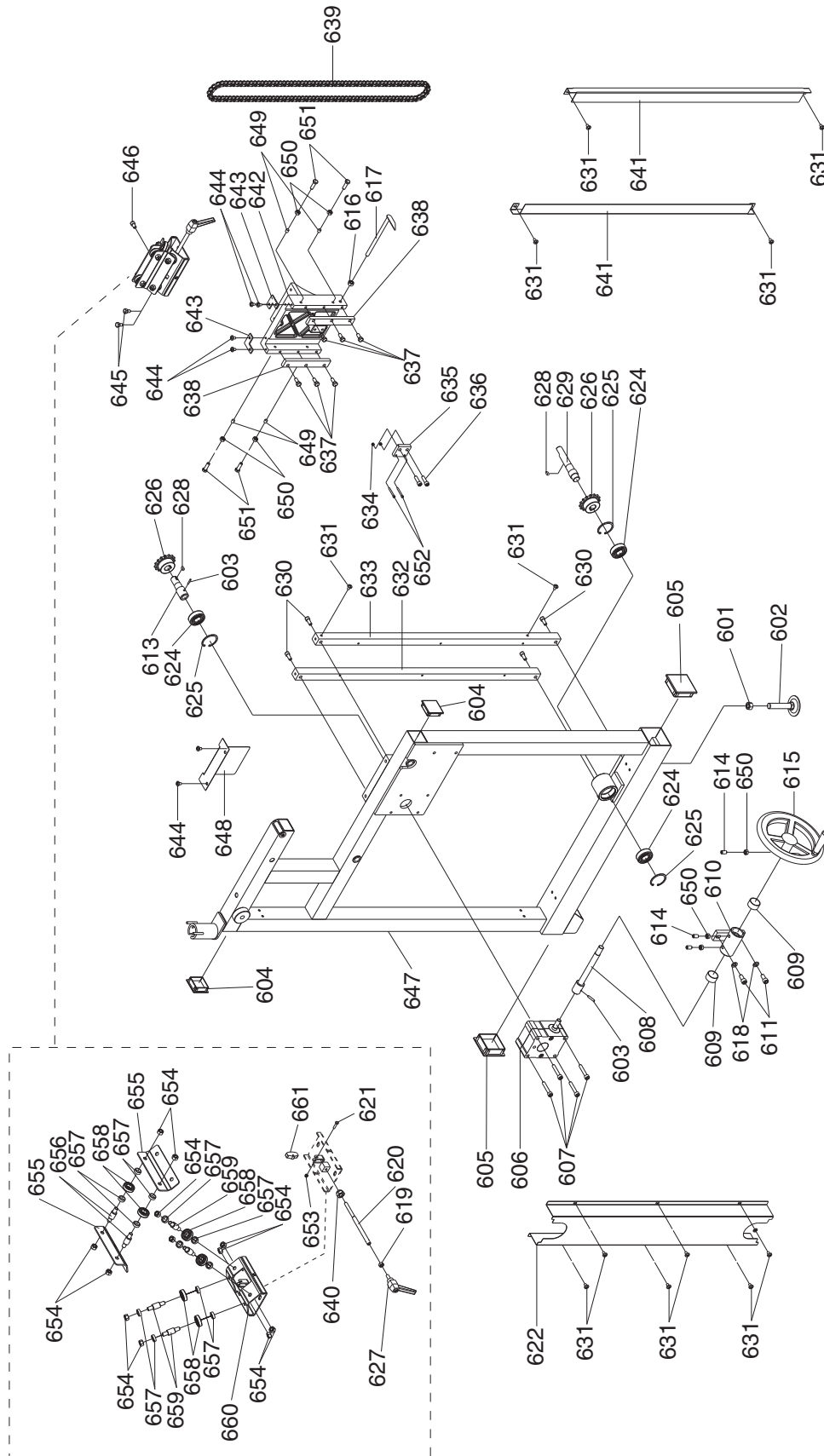

Left Upright Assembly Parts List

REF	PART #	DESCRIPTION
601	P0679601	HEX NUT 1/2"-12
602	P0679602	FOOT PAD
603	P0679603	SPECIAL PIN
604	P0679604	SQUARE CAP
605	P0679605	CAP
606	P0679606	GEAR BOX
607	P0679607	CAP SCREW M8-1.25 X 80
608	P0679608	HANDWHEEL SPINDLE
609	P0679609	COPPER TUBE
610	P0679610	HANDWHEEL ASSEMBLY
611	P0679611	CAP SCREW 3/8-16 X 3/4
613	P0679613	GEAR BOX SPINDLE
614	P0679614	SET SCREW 5/16-18 X 1/2
615	P0679615	HANDWHEEL
616	P0679616	HEX NUT 3/8"-16
617	P0679617	INDICATOR
618	P0679618	LOCK WASHER 3/8
619	P0679619	HEX NUT M8-1.25
620	P0679620	ADJUSTABLE BAR
621	P0679621	HEX BOLT M5-.8 X 20
622	P0679622	COVER
624	P0679624	BALL BEARING 6204ZZ
625	P0679625	INT RETAINING RING 47MM
626	P0679626	SPROCKET
627	P0679627	LOCK HANDLE
628	P0679628	KEY 5 X 5 X 10
629	P0679629	CHAIN SPINDLE ADAPTER
630	P0679630	CAP SCREW 5/16-18 X 3/4
631	P0679631	PHLP HD SCR 1/4-20 X 1/4
632	P0679632	GEAR BAR (LEFT)

REF	PART #	DESCRIPTION
633	P0679633	GEAR BAR (RIGHT)
634	P0679634	HEX NUT #8-32
635	P0679635	CHAIN FIXING BOARD
636	P0679636	CAP SCREW 5/16-18 X 1
637	P0679637	HEX BOLT 5/16-18 X 3/4
638	P0679638	FIXING BOARD
639	P0679639	CHAIN
640	P0679640	LOCK NUT 5/16-18
641	P0679641	CHAIN COVER
642	P0679642	COVER
643	P0679643	L-PLATE
644	P0679644	PHLP HD SCR 1/4-20 X 3/8
645	P0679645	HEX BOLT 5/16-18 X 1/2
646	P0679646	HEX BOLT 5/16-18 X 1/2
647	P0679647	SUPPORT FOOT (LEFT)
648	P0679648	DUST COVER
649	P0679649	COPPER WEAR PIN
650	P0679650	HEX NUT 5/16"-18
651	P0679651	HEX BOLT 5/16-18 X 1
652	P0679652	CAP SCREW #8-32 X 1
653	P0679653	LOCK NUT M5-.8
654	P0679654	HEX NUT 3/8"-16
655	P0679655	TRACKING ADJUSTABLE BOARD
656	P0679656	BEARING SPACER
657	P0679657	CAP
658	P0679658	BALL BEARING 6002ZZ
659	P0679659	TRACKING SPINDLE
660	P0679660	TRACKING SET
661	P0679661	SPINDLE FIXING BOARD



Platen Press Assembly Breakdown & Parts List

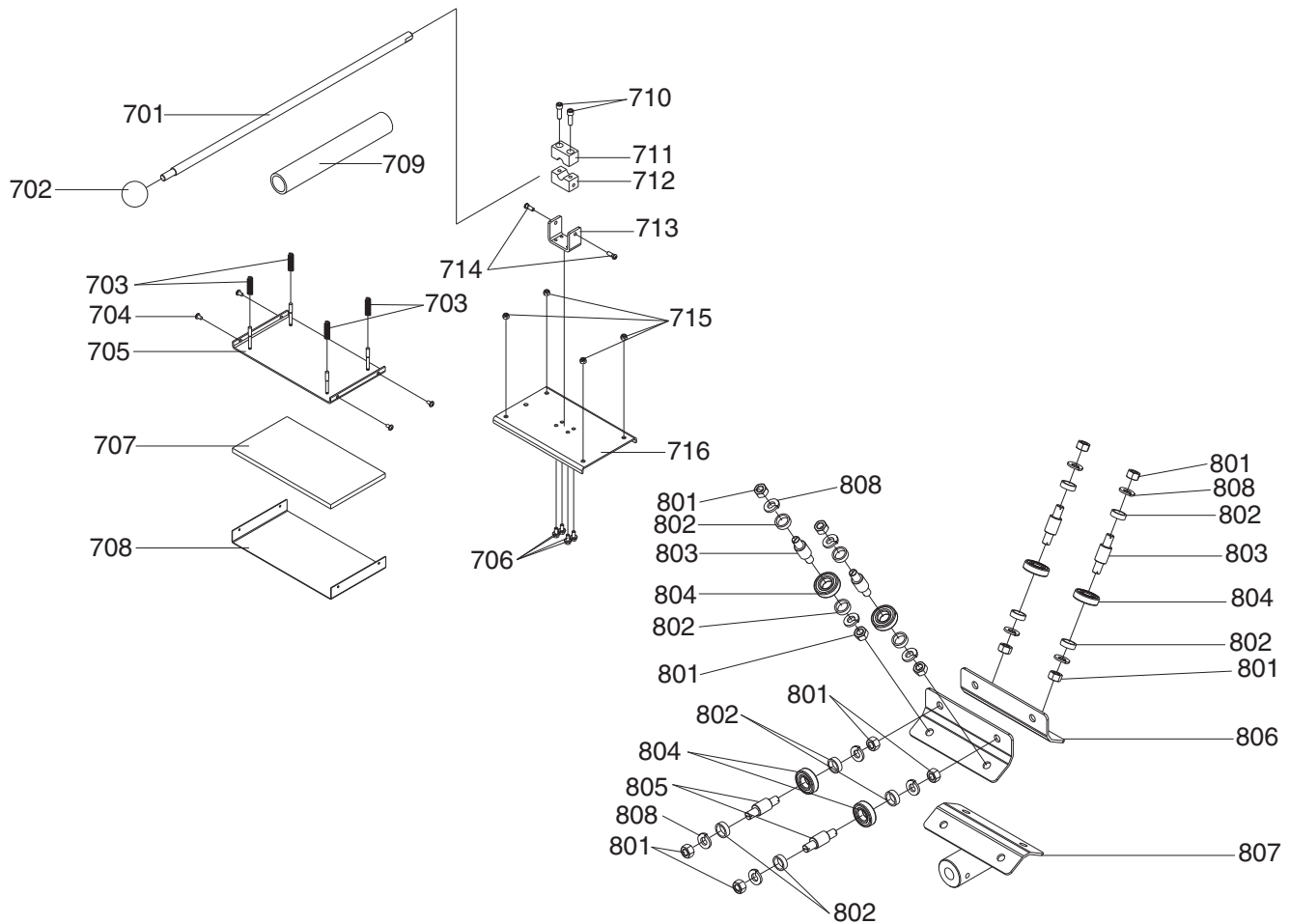

REF	PART #	DESCRIPTION
701	P0679701	PLATEN PRESS HANDLE
702	P0679702	BALL KNOB 1/2-12
703	P0679703	COMPRESSION SPRING
704	P0679704	PHLP HD SCR 3/16-18 X 3/8
705	P0679705	LOWER PRESS BRACKET
706	P0679706	FLANGE BOLT 1/4-20 X 1/2
707	P0679707	PLATEN FOAM PAD
708	P0679708	PLATEN GRAPHITE PAD
709	P0679709	FOAM TUBE
710	P0679710	CAP SCREW 5/16-18 X 1
711	P0679711	UPPER CLAMP PLATE
712	P0679712	LOWER CLAMP PLATE

REF	PART #	DESCRIPTION
713	P0679713	CLAMP BRACKET
714	P0679714	SPECIAL SCREW
715	P0679715	LOCK NUT 1/4-20
716	P0679716	UPPER PRESS BRACKET
801	P0679801	HEX NUT 3/8-16
802	P0679802	SPACER
803	P0679803	BEARING SHAFT
804	P0679804	BALL BEARING 6002ZZ
805	P0679805	ECCENTRIC BEARING SHAFT
806	P0679806	TRACKING PLATE
807	P0679807	PRESS BRACKET
808	P0679808	FLAT WASHER 3/8



Labels Breakdown & Parts List

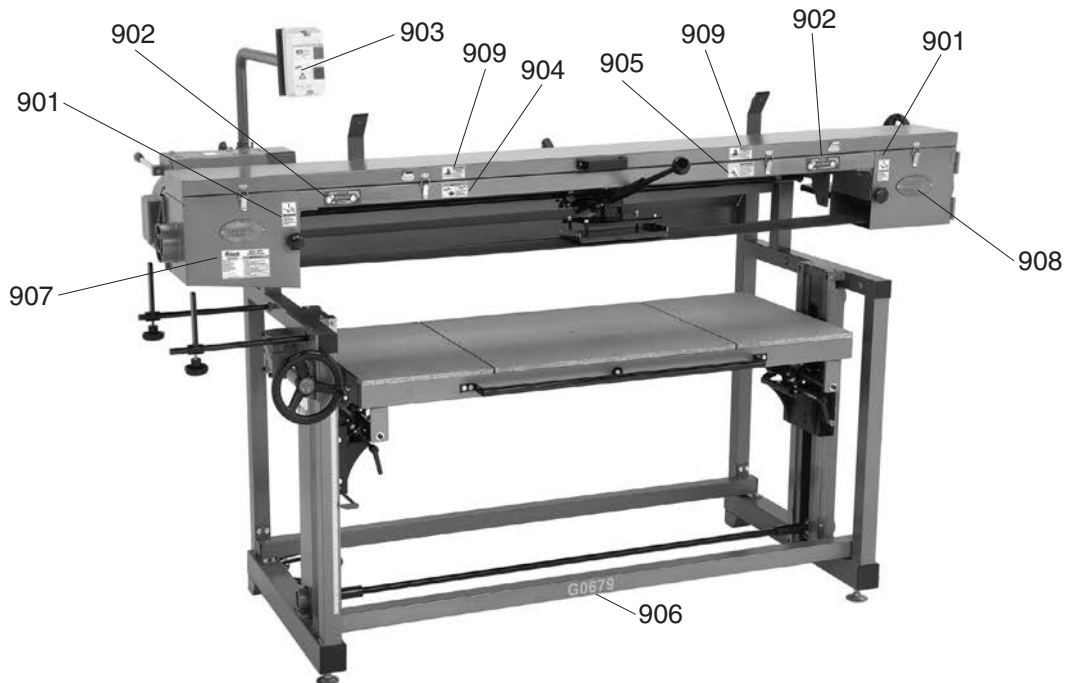

REF	PART #	DESCRIPTION
901	P0679901	DISCONNECT POWER LABEL VS
902	P0679902	BELT DIRECTION LABEL
903	P0679903	ELECTRICITY LABEL 0.7"
904	P0679904	GLASSES RESPIRATOR LABEL HS
905	P0679905	READ MANUAL LABEL HS

REF	PART #	DESCRIPTION
906	P0679906	MODEL NUMBER LABEL
907	P0679907	MACHINE ID LABEL
908	P0679908	GRIZZLY NAMEPLATE
909	P0679909	HAND INJURY WARNING LABEL
910	P0679910	DIRECTION ARROW LABEL

WARNING

Safety labels warn about machine hazards and ways to prevent injury. The owner of this machine **MUST** maintain the original location and readability of the labels on the machine. If any label is removed or becomes unreadable, **REPLACE** that label before using the machine again. Contact Grizzly at (800) 523-4777 or www.grizzly.com to order new labels.





WARRANTY CARD

Name _____
 Street _____
 City _____ State _____ Zip _____
 Phone # _____ Email _____
 Model # _____ Order # _____ Serial # _____

The following information is given on a voluntary basis. It will be used for marketing purposes to help us develop better products and services. **Of course, all information is strictly confidential.**

1. How did you learn about us?

Advertisement Friend Catalog
 Card Deck Website Other:

2. Which of the following magazines do you subscribe to?

<input type="checkbox"/> Cabinetmaker & FDM	<input type="checkbox"/> Popular Science	<input type="checkbox"/> Wooden Boat
<input type="checkbox"/> Family Handyman	<input type="checkbox"/> Popular Woodworking	<input type="checkbox"/> Woodshop News
<input type="checkbox"/> Hand Loader	<input type="checkbox"/> Precision Shooter	<input type="checkbox"/> Woodsmith
<input type="checkbox"/> Handy	<input type="checkbox"/> Projects in Metal	<input type="checkbox"/> Woodwork
<input type="checkbox"/> Home Shop Machinist	<input type="checkbox"/> RC Modeler	<input type="checkbox"/> Woodworker West
<input type="checkbox"/> Journal of Light Cont.	<input type="checkbox"/> Rifle	<input type="checkbox"/> Woodworker's Journal
<input type="checkbox"/> Live Steam	<input type="checkbox"/> Shop Notes	<input type="checkbox"/> Other:
<input type="checkbox"/> Model Airplane News	<input type="checkbox"/> Shotgun News	
<input type="checkbox"/> Old House Journal	<input type="checkbox"/> Today's Homeowner	
<input type="checkbox"/> Popular Mechanics	<input type="checkbox"/> Wood	

3. What is your annual household income?

\$20,000-\$29,000 \$30,000-\$39,000 \$40,000-\$49,000
 \$50,000-\$59,000 \$60,000-\$69,000 \$70,000+

4. What is your age group?

20-29 30-39 40-49
 50-59 60-69 70+

5. How long have you been a woodworker/metalworker?

0-2 Years 2-8 Years 8-20 Years 20+ Years

6. How many of your machines or tools are Grizzly?

0-2 3-5 6-9 10+

7. Do you think your machine represents a good value? Yes No

8. Would you recommend Grizzly Industrial to a friend? Yes No

9. Would you allow us to use your name as a reference for Grizzly customers in your area?

Note: We never use names more than 3 times. Yes No

10. Comments: _____

CUT ALONG DOTTED LINE

FOLD ALONG DOTTED LINE



Place
Stamp
Here



GRIZZLY INDUSTRIAL, INC.
P.O. BOX 2069
BELLINGHAM, WA 98227-2069



FOLD ALONG DOTTED LINE

Send a Grizzly Catalog to a friend:

Name _____

Street _____

City _____ State _____ Zip _____

TAPE ALONG EDGES--PLEASE DO NOT STAPLE

WARRANTY AND RETURNS

Grizzly Industrial, Inc. warrants every product it sells for a period of **1 year** to the original purchaser from the date of purchase. This warranty does not apply to defects due directly or indirectly to misuse, abuse, negligence, accidents, repairs or alterations or lack of maintenance. This is Grizzly's sole written warranty and any and all warranties that may be implied by law, including any merchantability or fitness, for any particular purpose, are hereby limited to the duration of this written warranty. We do not warrant or represent that the merchandise complies with the provisions of any law or acts unless the manufacturer so warrants. In no event shall Grizzly's liability under this warranty exceed the purchase price paid for the product and any legal actions brought against Grizzly shall be tried in the State of Washington, County of Whatcom.

We shall in no event be liable for death, injuries to persons or property or for incidental, contingent, special, or consequential damages arising from the use of our products.

To take advantage of this warranty, contact us by mail or phone and give us all the details. We will then issue you a "Return Number," which must be clearly posted on the outside as well as the inside of the carton. We will not accept any item back without this number. Proof of purchase must accompany the merchandise.

The manufacturers reserve the right to change specifications at any time because they constantly strive to achieve better quality equipment. We make every effort to ensure that our products meet high quality and durability standards and we hope you never need to use this warranty.

Please feel free to write or call us if you have any questions about the machine or the manual.

Thank you again for your business and continued support. We hope to serve you again soon.

grizzly.com[®]
TOOL WEBSITE

Buy Direct and Save with Grizzly[®] – Trusted, Proven and a Great Value!
~Since 1983~

*Visit Our Website Today For
Current Specials!*

**ORDER
24 HOURS A DAY!
1-800-523-4777**

