

# READ THIS FIRST



For questions or help with this product contact Tech Support at (570) 546-9663 or [techsupport@grizzly.com](mailto:techsupport@grizzly.com)

**Model G0605X1/G0606X1/  
G0696X/G0697X**

**\*\*\*IMPORTANT UPDATE\*\*\***

**For Machines Mfd. Since 10/23  
and Owner's Manual Revised 10/14**

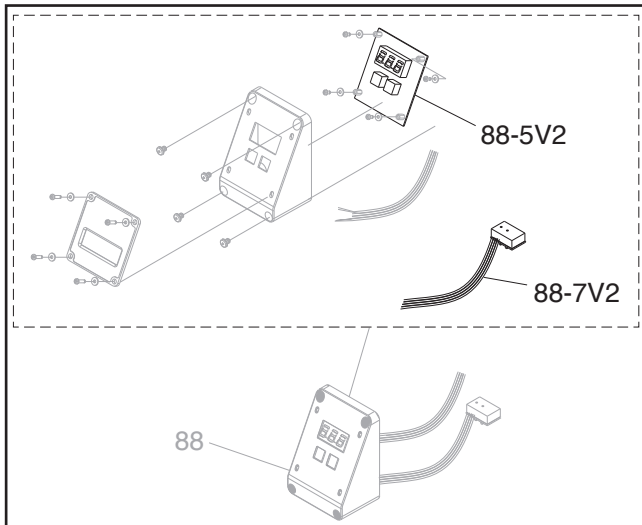
The following changes were recently made since the owner's manual was printed:

- Parts have changed.

Aside from this information, all other content in the owner's manual applies and **MUST** be read and understood for your own safety. **IMPORTANT: Keep this update with the owner's manual for future reference.**

For questions or help, contact our Tech Support at (570) 546-9663 or [techsupport@grizzly.com](mailto:techsupport@grizzly.com).

## Revised Parts



## Revised G0605X1 Parts List

REF	PART #	DESCRIPTION
88-5V2	P0605X1088-5V2	CIRCUIT BOARD CBEC V2.10.23
88-7V2	P0605X1088-7V2	DATA CORD 24G 4W 8" V2.10.23

## Revised G0606X1 Parts List

REF	PART #	DESCRIPTION
88-5V2	P0606X1088-5V2	CIRCUIT BOARD CBEC V2.10.23
88-7V2	P0606X1088-7V2	DATA CORD 24G 4W 8" V2.10.23

## Revised G0696X Parts List

REF	PART #	DESCRIPTION
88-5V2	P0696X088-5V2	CIRCUIT BOARD CBEC V2.10.23
88-7V2	P0696X088-7V2	DATA CORD 24G 4W 8" V2.10.23

## Revised G0697X Parts List

REF	PART #	DESCRIPTION
88-5V2	P0697X088-5V2	CIRCUIT BOARD CBEC V2.10.23
88-7V2	P0697X088-7V2	DATA CORD 24G 4W 8" V2.10.23



COPYRIGHT © OCTOBER, 2023 BY GRIZZLY INDUSTRIAL, INC.  
**WARNING: NO PORTION OF THIS MANUAL MAY BE REPRODUCED IN ANY SHAPE  
OR FORM WITHOUT THE WRITTEN APPROVAL OF GRIZZLY INDUSTRIAL, INC.**  
#JP22929 PRINTED IN TAIWAN

# READ THIS FIRST



Model G0605X1, G0606X1,  
G0696X, G0697X  
**\*\*\*IMPORTANT UPDATE\*\*\***  
For Machines Mfd. Since 07/21  
and Owner's Manual Revised 10/14

For questions or help with this product contact Tech Support at (570) 546-9663 or [techsupport@grizzly.com](mailto:techsupport@grizzly.com)

The following changes were made since the owner's manual was printed:

- Blade guard changed.
- Model G0605X1/G0606X1 extension tables now ship in Carton #1.

Aside from this information, all other content in the owner's manual applies and **MUST** be read and understood for your own safety. **IMPORTANT: Keep this update with the owner's manual for future reference.**

For questions or help, contact our Tech Support at (570) 546-9663 or [techsupport@grizzly.com](mailto:techsupport@grizzly.com).

## Revised G0605X1 Specifications

### Shipping Dimensions:

#### Carton #1

Content..... Machine & Extension Tables  
Weight..... 785 lbs.  
Length x Width x Height..... 46 x 43 x 42 in.

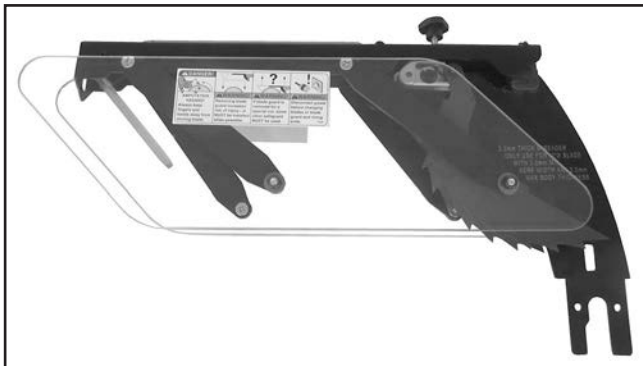
## Revised G0606X1 Specifications

### Shipping Dimensions:

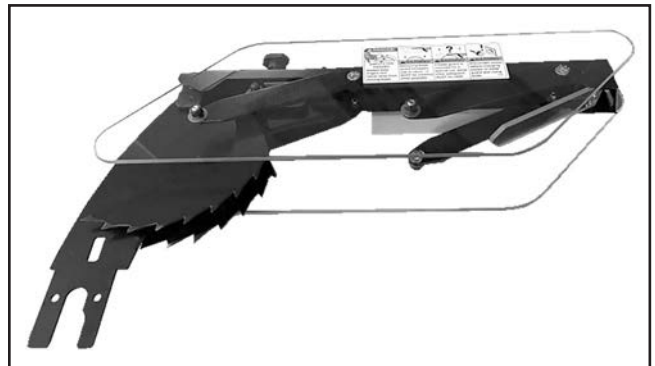
#### Carton #1

Content..... Machine & Extension Tables  
Weight..... 783 lbs.  
Length x Width x Height..... 46 x 43 x 42 in.

## New Blade Guard (V4)

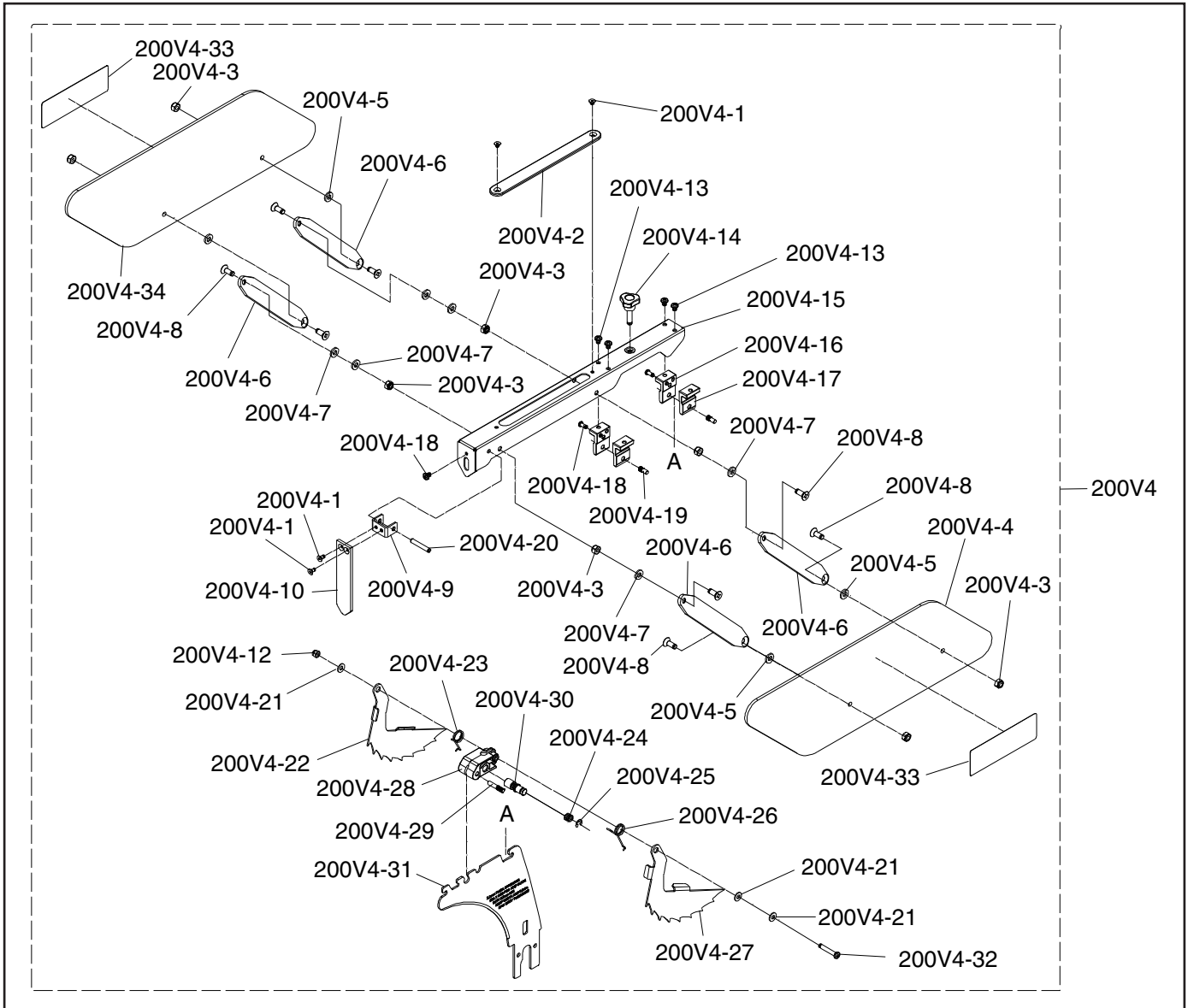


## Old Blade Guard (V3)



COPYRIGHT © MAY, 2021 BY GRIZZLY INDUSTRIAL, INC.  
**WARNING: NO PORTION OF THIS MANUAL MAY BE REPRODUCED IN ANY SHAPE  
OR FORM WITHOUT THE WRITTEN APPROVAL OF GRIZZLY INDUSTRIAL, INC.**  
#CS21910 PRINTED IN TAIWAN

# Revised Blade Guard Parts



REF	PART #	DESCRIPTION
200V4	P0605X1200V4	BLADE GUARD ASSY V4.07.21
200V4-1	P0605X1200V4-1	FLAT HD SCR M4-.7 X 8
200V4-2	P0605X1200V4-2	UPPER COVER
200V4-3	P0605X1200V4-3	HEX NUT M6-1
200V4-4	P0605X1200V4-4	BLADE GUARD COVER (RIGHT)
200V4-5	P0605X1200V4-5	FLAT WASHER 6MM
200V4-6	P0605X1200V4-6	CONNECTING PLATE
200V4-7	P0605X1200V4-7	FLAT WASHER 6MM
200V4-8	P0605X1200V4-8	FLAT HD SCR M6-1 X 16
200V4-9	P0605X1200V4-9	BRACKET
200V4-10	P0605X1200V4-10	REAR COVER
200V4-12	P0605X1200V4-12	HEX NUT M5-.8
200V4-13	P0605X1200V4-13	PHLP HD SCR M5-.8 X 6
200V4-14	P0605X1200V4-14	KNOB BOLT 3-LOBE, M6-1 X 35
200V4-15	P0605X1200V4-15	BLADE GUARD BODY
200V4-16	P0605X1200V4-16	MOUNTING BLOCK (LEFT)
200V4-17	P0605X1200V4-17	MOUNTING BLOCK (RIGHT)

REF	PART #	DESCRIPTION
200V4-18	P0605X1200V4-18	PHLP HD SCR M4-.7 X 10
200V4-19	P0605X1200V4-19	MOUNTING PIN
200V4-20	P0605X1200V4-20	ROLL PIN 5 X 45
200V4-21	P0605X1200V4-21	FLAT WASHER 5MM
200V4-22	P0605X1200V4-22	ANTI-KICKBACK PAWL (LEFT)
200V4-23	P0605X1200V4-23	TORSION SPRING (LEFT)
200V4-24	P0605X1200V4-24	COMPRESSION SPRING
200V4-25	P0605X1200V4-25	E-CLIP 7MM
200V4-26	P0605X1200V4-26	TORSION SPRING (RIGHT)
200V4-27	P0605X1200V4-27	ANTI-KICKBACK PAWL (RIGHT)
200V4-28	P0605X1200V4-28	PAWL MOUNTING BRACKET
200V4-29	P0605X1200V4-29	PIN
200V4-30	P0605X1200V4-30	SHAFT
200V4-31	P0605X1200V4-31	SPREADER
200V4-32	P0605X1200V4-32	PHLP HD SCR M5-.8 X 30
200V4-33	P0605X1200V4-33	BLADE GUARD WARNING LABEL
200V4-34	P0605X1200V4-34	BLADE GUARD COVER (LEFT)



# READ THIS FIRST



Models G0605X1/G0606X1/  
G0696X/G0697X

**\*\*\*IMPORTANT UPDATE\*\*\***

For Machines Mfd. Since 07/16  
and Owner's Manual Revised 10/14

For questions or help with this product contact Tech Support at (570) 546-9663 or [techsupport@grizzly.com](mailto:techsupport@grizzly.com)

The following changes were recently made to this machine since the owner's manual was printed:

- Contactor manufacturer changed appearance/terminal numbers.
- Motor junction box wiring has changed.

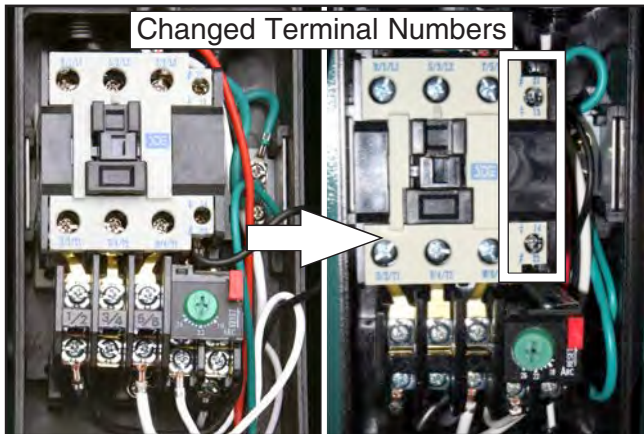
Aside from this information, all other content in the owner's manual applies and **MUST** be read and understood for your own safety. **IMPORTANT: Keep this update with the owner's manual for future reference.**

For questions or help, contact our Tech Support at (570) 546-9663 or [techsupport@grizzly.com](mailto:techsupport@grizzly.com).

## G0605X1/G0696X Magnetic Switch

OLD

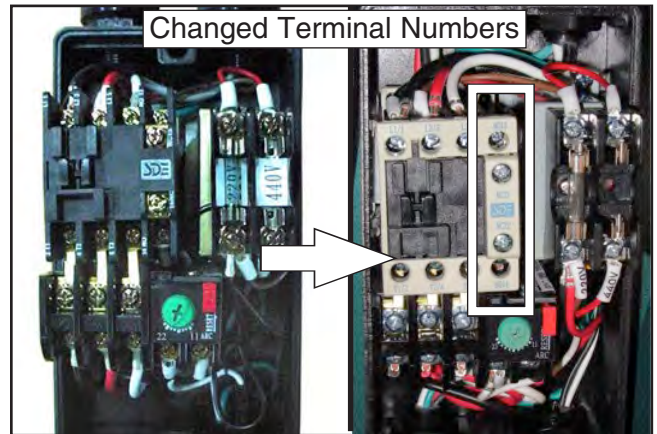
NEW



## G0606X1/G0697X Magnetic Switch

OLD

NEW



## G0606X1/G0697X Magnetic Switch

OLD

NEW

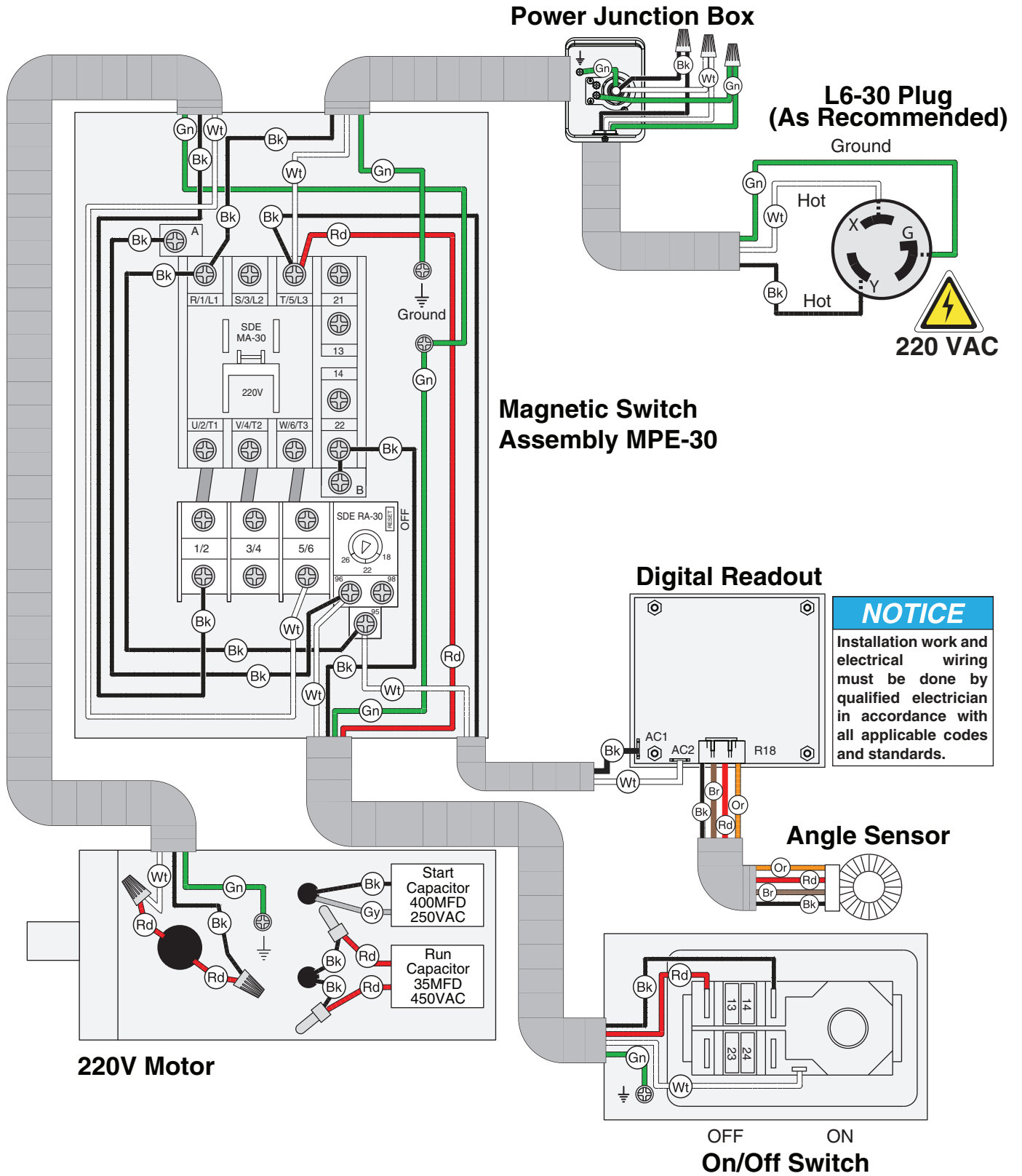


COPYRIGHT © MARCH, 2017 BY GRIZZLY INDUSTRIAL, INC. REVISED, FEBRUARY 2021 (BL)

**WARNING: NO PORTION OF THIS MANUAL MAY BE REPRODUCED IN ANY SHAPE  
OR FORM WITHOUT THE WRITTEN APPROVAL OF GRIZZLY INDUSTRIAL, INC.**

#JH18863 PRINTED IN TAIWAN

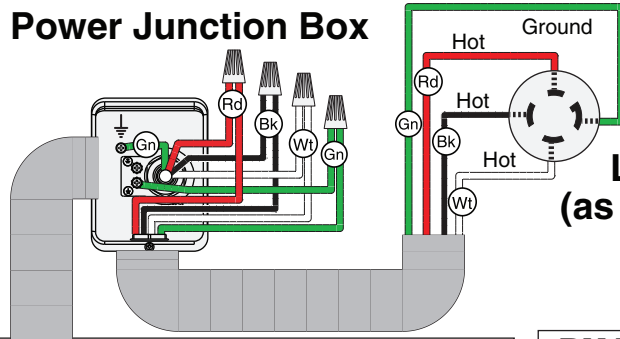
# G0605X1/G0696X Wiring 220V, 1-Ph



# G0606X1/G0697X Wiring 220V, 3-Ph

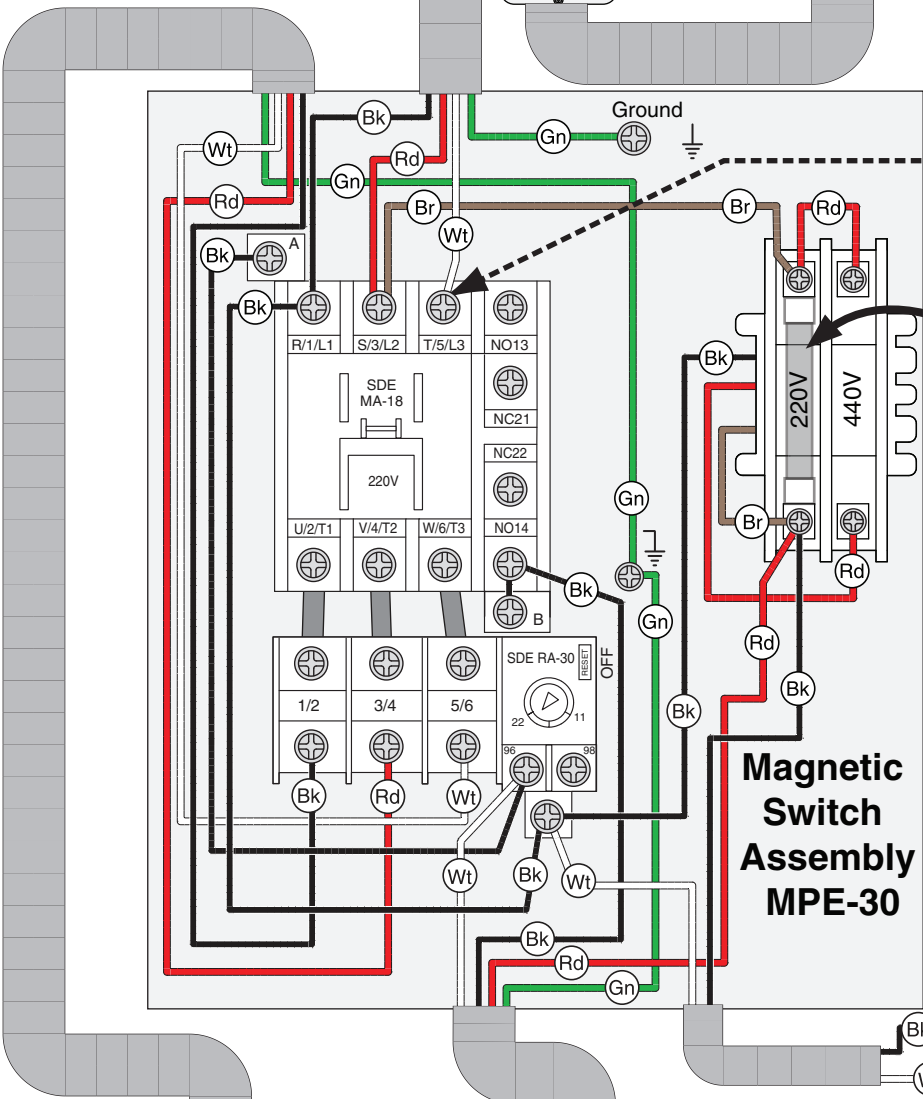
**MOTOR DIRECTION NOTICE**  
 If motor rotates in opposite direction, swap any two power source wires at the incoming terminals.

## Power Junction Box



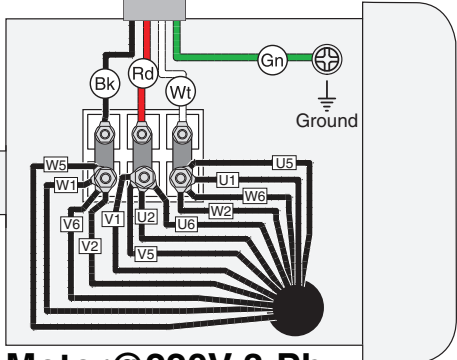
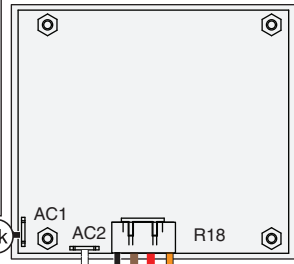
220 VAC  
**L15-30 PLUG**  
 (as recommended)

**PHASE CONVERTER NOTICE**  
 If connecting machine to a phase converter, the manufactured leg must be connected to terminal L3.

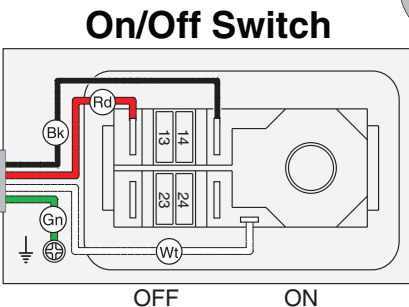


**Magnetic Switch Assembly MPE-30**

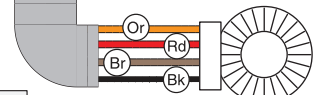
**Digital Readout**



**Motor @ 220V 3-Ph**



**On/Off Switch**



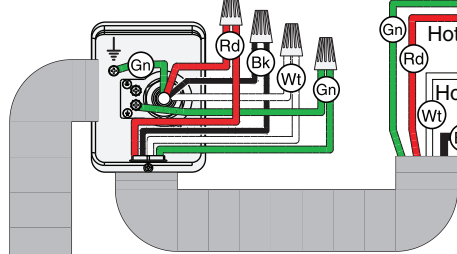
**Angle Sensor**



# G0606X1/G0697X Wiring 440V, 3-Ph

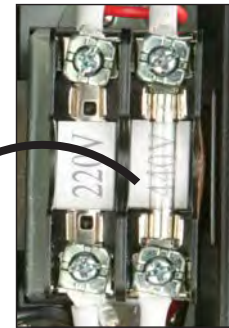
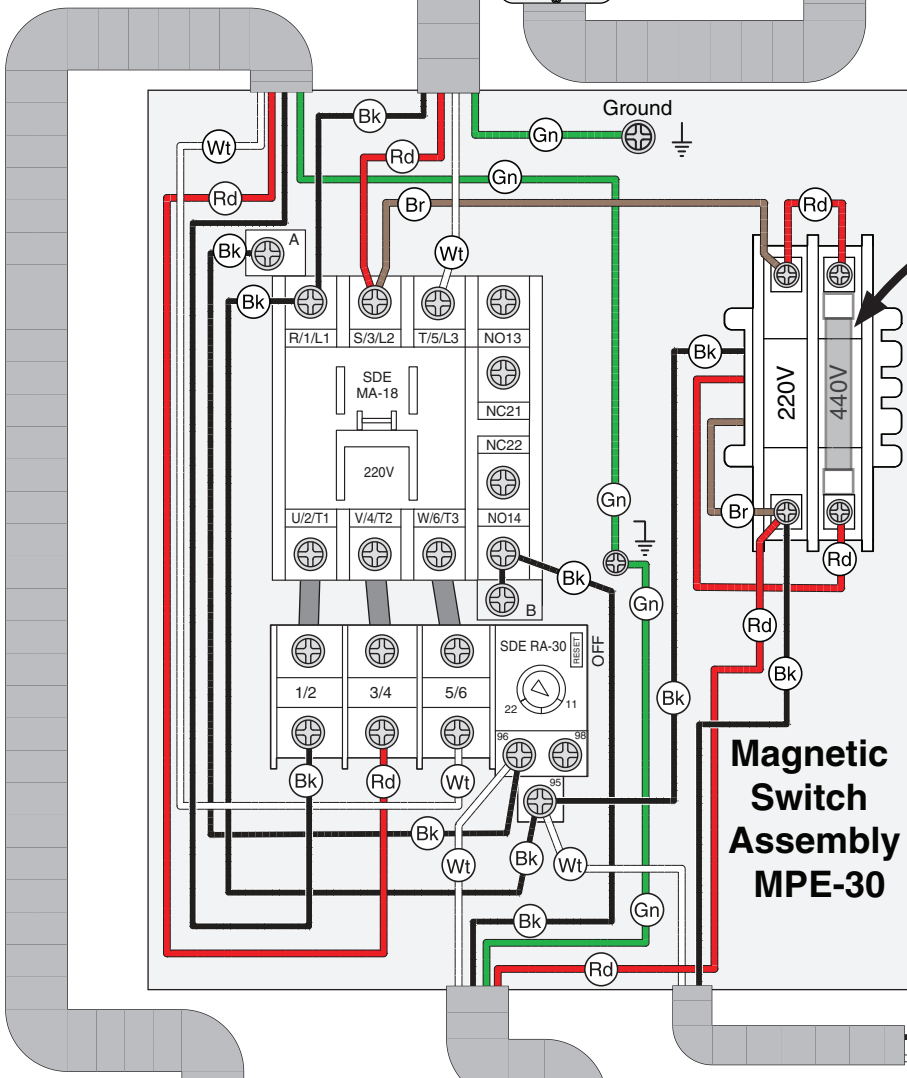
**MOTOR DIRECTION NOTICE**  
 If motor rotates in opposite direction, swap any two power source wires at the incoming terminals.

## Power Junction Box

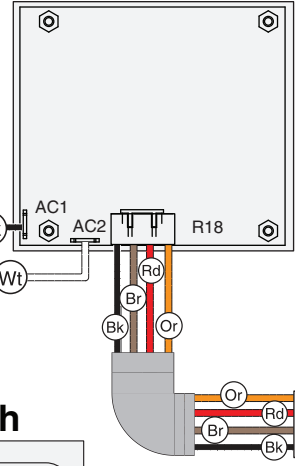


**3-PHASE 440 VAC**

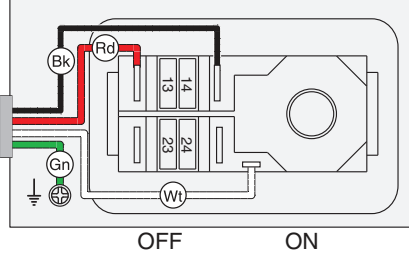
**DISCONNECT SWITCH (as recommended)**



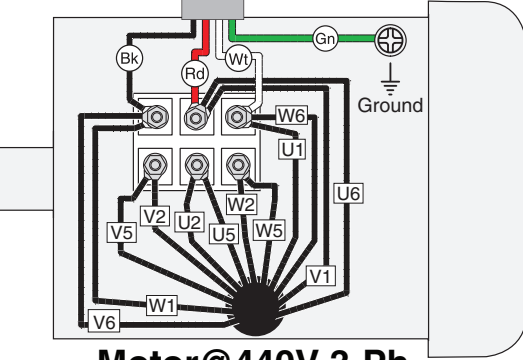
## Digital Readout



## On/Off Switch



## Angle Sensor



**Motor @ 440V 3-Ph**



**READ ELECTRICAL SAFETY ON PAGE 78!**



# READ THIS FIRST



**Model G0605X1/G0606X1**  
**\*\*\*IMPORTANT UPDATE\*\*\***

For Machines Mfd. Since 07/17  
and Owner's Manual Revised 10/14

For questions or help with this product contact Tech Support at (570) 546-9663 or [techsupport@grizzly.com](mailto:techsupport@grizzly.com)

The following changes were recently made since the owner's manual was printed:

- Revised inventory list.
- Revised **Step 2** in G0605X1/G0606X1 Outfeed Table assembly instructions.

Aside from this information, all other content in the owner's manual applies and **MUST** be read and understood for your own safety. **IMPORTANT: Keep this update with the owner's manual for future reference.**

For questions or help, contact our Tech Support at (570) 546-9663 or [techsupport@grizzly.com](mailto:techsupport@grizzly.com).

## Revised Outfeed Table Inventory

**Box Contents: (Figure 15)** Qty  
F. Front Outfeed Table Bracket ..... 1

**Hardware and Tools (Not Shown):** Qty  
• Tap Screws M4 x 16  
(Outfeed Table/Bracket) ..... 8

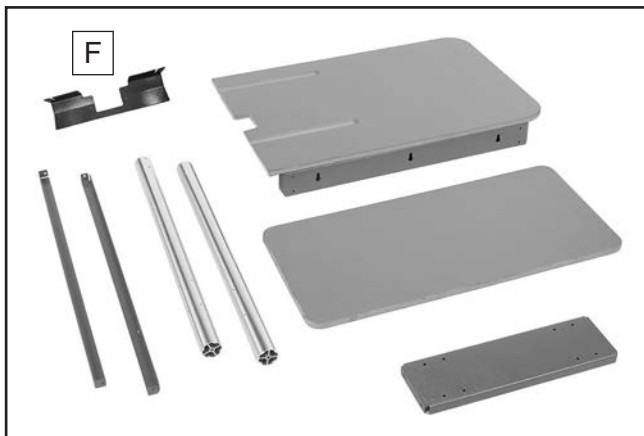


Figure 15. Outfeed table components.

## Revised Assembly Steps G0605X1/G0606X1 Outfeed Table

2. Attach front outfeed table bracket to outfeed table with (8) M4 x 16 tap screws (**see Figure 36**), and then install feet, support legs, and shelf end plate in same manner as described in **Extension Table** instructions on **Page 23**.

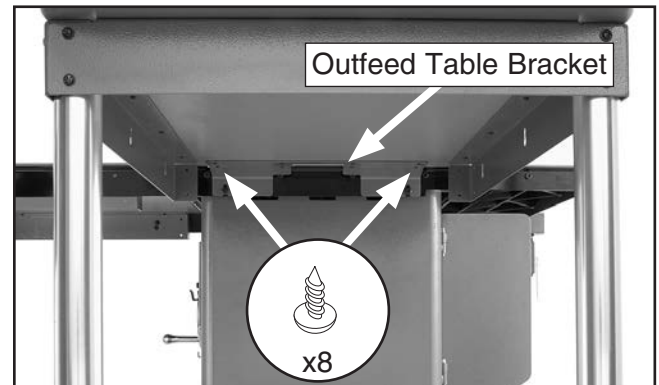


Figure 36. Outfeed table fastened to rear rail.

# *Grizzly* **Industrial, Inc.**®

## **MODEL G0605X1/G0606X1/ G0696X/G0697X 12" LEFT TILTING TABLE SAW OWNER'S MANUAL**



COPYRIGHT © FEBRUARY, 2009 BY GRIZZLY INDUSTRIAL, INC. REVISED OCTOBER, 2014 (WK)  
**WARNING: NO PORTION OF THIS MANUAL MAY BE REPRODUCED IN ANY SHAPE  
OR FORM WITHOUT THE WRITTEN APPROVAL OF GRIZZLY INDUSTRIAL, INC.**  
(FOR MODELS MANUFACTURED SINCE 8/11) #BL11524 PRINTED IN TAIWAN



## **WARNING!**

**This manual provides critical safety instructions on the proper setup, operation, maintenance, and service of this machine/tool. Save this document, refer to it often, and use it to instruct other operators.**

**Failure to read, understand and follow the instructions in this manual may result in fire or serious personal injury—including amputation, electrocution, or death.**

**The owner of this machine/tool is solely responsible for its safe use. This responsibility includes but is not limited to proper installation in a safe environment, personnel training and usage authorization, proper inspection and maintenance, manual availability and comprehension, application of safety devices, cutting/sanding/grinding tool integrity, and the usage of personal protective equipment.**

**The manufacturer will not be held liable for injury or property damage from negligence, improper training, machine modifications or misuse.**



## **WARNING!**

**Some dust created by power sanding, sawing, grinding, drilling, and other construction activities contains chemicals known to the State of California to cause cancer, birth defects or other reproductive harm. Some examples of these chemicals are:**

- **Lead from lead-based paints.**
- **Crystalline silica from bricks, cement and other masonry products.**
- **Arsenic and chromium from chemically-treated lumber.**

**Your risk from these exposures varies, depending on how often you do this type of work. To reduce your exposure to these chemicals: Work in a well ventilated area, and work with approved safety equipment, such as those dust masks that are specially designed to filter out microscopic particles.**

# Table of Contents

<b>INTRODUCTION</b> .....	<b>2</b>	<b>SECTION 5: SHOP MADE SAFETY</b>	
Manual Accuracy .....	2	<b>ACCESSORIES</b> .....	<b>50</b>
Contact Info.....	2	Featherboards.....	50
Machine Description .....	2	Push Sticks .....	53
Identification.....	3	Push Blocks .....	54
Machine Data Sheets .....	4	Narrow-Rip Auxiliary Fence & Push Block ..	55
<b>SECTION 1: SAFETY</b> .....	<b>5</b>	Outfeed & Support Tables .....	57
Safety Instructions for Machinery .....	5	Crosscut Sled.....	57
Additional Safety for Table Saws.....	7	<b>SECTION 6: ACCESSORIES</b> .....	<b>58</b>
Preventing Kickback .....	8	<b>SECTION 7: MAINTENANCE</b> .....	<b>60</b>
Protecting Yourself From Kickback.....	8	Schedule .....	60
Glossary of Terms .....	9	Cleaning.....	60
<b>SECTION 2: POWER SUPPLY</b> .....	<b>10</b>	Unpainted Cast Iron.....	60
Correcting Phase Polarity .....	12	Lubrication .....	61
Voltage Conversion.....	13	<b>SECTION 8: SERVICE</b> .....	<b>62</b>
<b>SECTION 3: SETUP</b> .....	<b>14</b>	Troubleshooting .....	62
Needed for Setup.....	14	Blade Tilt Stops.....	64
Unpacking .....	14	Miter Slot to Blade Parallelism.....	66
Hardware Recognition Chart .....	15	Blade Alignment.....	67
G0605X1/G0606X1 Inventory.....	16	Spreader or Riving Knife Alignment .....	68
G0696X/G0697X Inventory.....	17	Fence Adjustments .....	70
Cleanup.....	19	Fence Scale Calibration.....	72
Site Considerations.....	20	Miter Gauge Adjustments .....	73
Assembly .....	21	Table Tilt Handwheel Backlash .....	74
Dust Collection.....	26	Digital Readout Calibration .....	74
Power Connection.....	27	Belt Tension & Replacement .....	75
Test Run .....	28	<b>SECTION 9: WIRING</b> .....	<b>77</b>
Final Setup.....	29	Wiring Safety Instructions .....	77
Recommended Adjustments.....	29	Common Electrical Components .....	78
<b>SECTION 4: OPERATIONS</b> .....	<b>30</b>	G0605X1/G0696X Wiring 220V, 1-Ph .....	79
Basic Controls.....	30	G0606X1/G0697X Electrical Components ..	80
Operation Overview .....	31	G0606X1/G0697X Wiring 220V, 3-Ph .....	81
Disabling & Locking Switch.....	31	G0606X1/G0697X Wiring 440V, 3-Ph .....	82
Non-Through & Through Cuts .....	32	<b>SECTION 10: PARTS</b> .....	<b>83</b>
Stock Inspection.....	32	Motor and Arbor.....	83
Blade Requirements .....	33	Cabinet.....	86
Blade Selection .....	33	Blade Guard.....	88
Blade Installation.....	34	Fence .....	89
Blade Guard Assembly .....	35	Miter Gauge .....	90
Riving Knife.....	38	Extension Table (G0605X1/G0606X1) .....	91
Cutting a Zero Clearance Insert .....	39	Rails (Model G0696X/G0697X) .....	92
Ripping.....	40	Outfeed Table (G0605X1/G0606X1) .....	93
Crosscutting .....	41	Labels & Cosmetic Parts .....	94
Miter Cuts.....	41	<b>WARRANTY AND RETURNS</b> .....	<b>97</b>
Blade Tilt/Bevel Cuts .....	42		
Dado Cutting.....	42		
Rabbit Cutting.....	45		
Resawing .....	47		

# INTRODUCTION

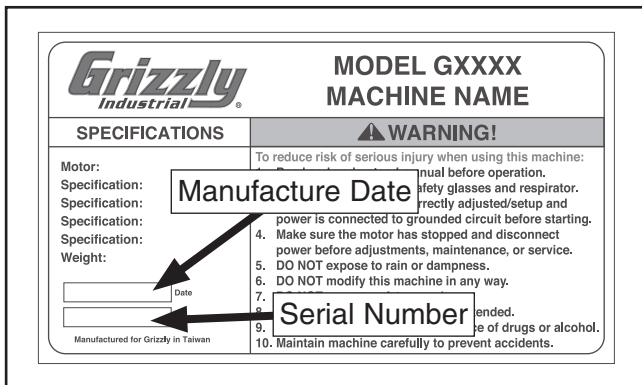
## Manual Accuracy

We are proud to provide a high-quality owner's manual with your new machine!

We made every effort to be exact with the instructions, specifications, drawings, and photographs contained inside. Sometimes we make mistakes, but our policy of continuous improvement also means that **sometimes the machine you receive will be slightly different than what is shown in the manual.**

If you find this to be the case, and the difference between the manual and machine leaves you confused about a procedure, check our website for an updated version. We post current manuals and manual updates for free on our website at **www.grizzly.com.**

Alternatively, you can call our Technical Support for help. Before calling, please write down the **Manufacture Date** and **Serial Number** stamped into the machine ID label (see below). This information helps us determine if updated documentation is available for your machine.



## Contact Info

We stand behind our machines. If you have any questions or need help, use the information below to contact us. Before contacting, please get the serial number and manufacture date of your machine. This will help us help you faster.

Grizzly Technical Support  
1203 Lycoming Mall Circle  
Muncy, PA 17756  
Phone: (570) 546-9663  
Email: techsupport@grizzly.com

We want your feedback on this manual. What did you like about it? Where could it be improved? Please take a few minutes to give us feedback.

Grizzly Documentation Manager  
P.O. Box 2069  
Bellingham, WA 98227-2069  
Email: manuals@grizzly.com

## Machine Description

This table saw features a steel cabinet-type stand with a precision-ground cast iron table, plus outfeed and extension tables for supporting wide panels before, during and after a cut. Depending upon the model, the motor is 5 or 7½ HP.

An internal dust port and sloped cabinet floor directs saw dust into the 4" dust port, providing highly effective dust removal. A poly-V serpentine belt system efficiently transfers power.

Includes a digital blade-angle readout, T-style fence, miter gauge, quick-release spreader/blade guard, riving knife, and a zero-clearance table insert.



# Identification

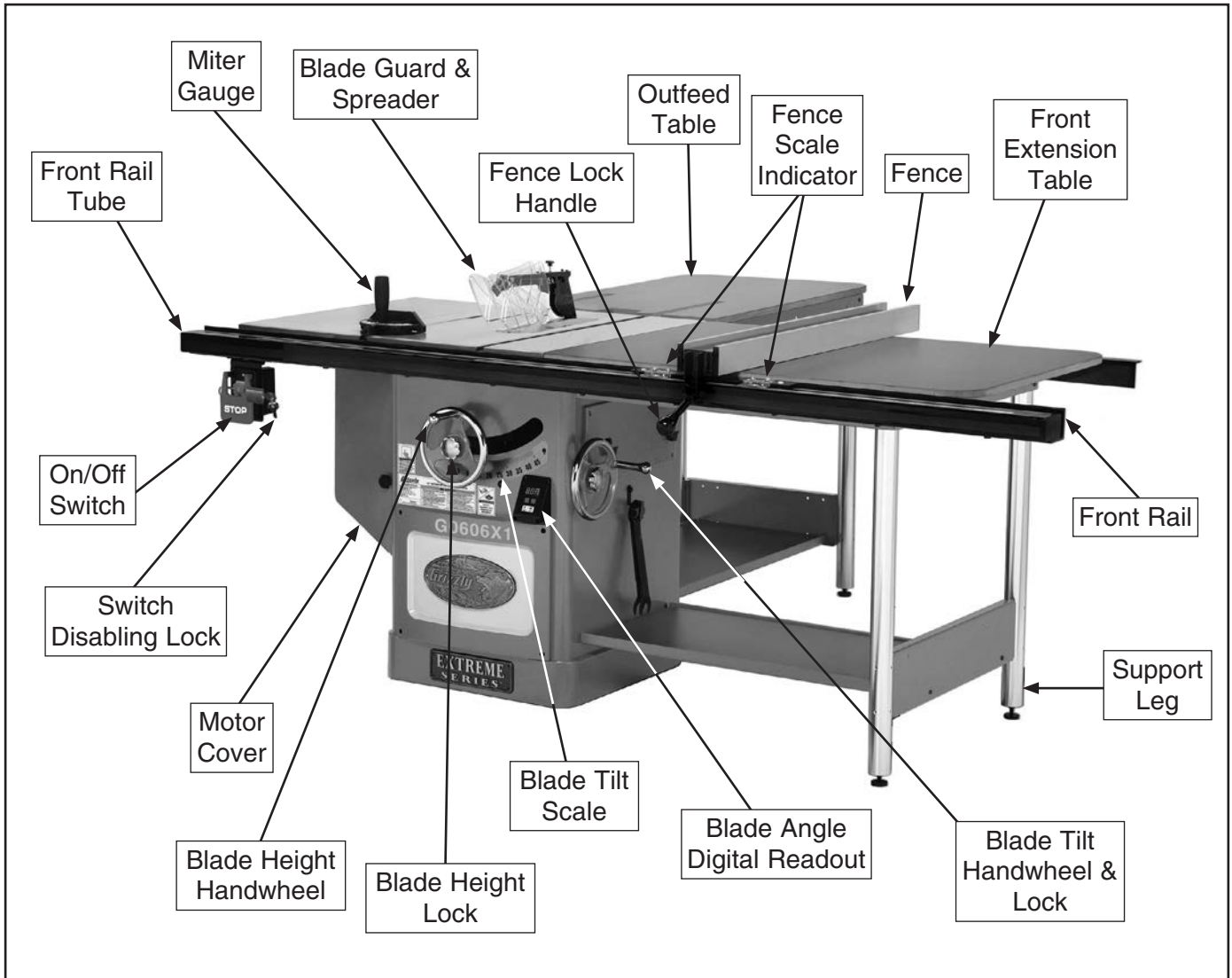
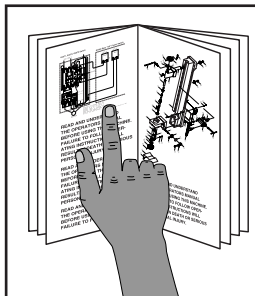


Figure 1. G0606X1 identification.



**⚠️ WARNING**  
To reduce the risk of serious injury when using this machine, read and understand this entire manual before beginning any operations.

**⚠️ WARNING**  
For Your Own Safety Read Instruction Manual Before Operating Saw

- Wear eye protection.
- Use saw-blade guard and spreader for every operation for which it can be used, including all through sawing.
- Keep hands out of the line of saw blade.
- Use a push-stick when required.
- Pay particular attention to instructions on reducing risk of kickback.
- Do not perform any operation freehand.
- Never reach around or over saw blade.





# MACHINE DATA SHEET

© Grizzly Industrial, Inc. • Customer Service: (800) 523-4777 • Tech Support: (570) 546-9663

## MODEL G0605X1/G0606X1/G0696X/G0697X 12" LEFT-TILTING TABLE SAWS

Model Number	G0605X1	G0606X1	G0696X	G0697X
Motor	5 HP, 220V, 1-Ph	7½ HP, 220V/440V, 3-Ph	5 HP, 220V, 1-Ph	7½ HP, 220V/440V, 3-Ph
Required Power Supply Circuit	30 Amps	30 Amps @220V 15 Amps @440V	30 Amps	30 Amps @220V 15 Amps @440V
Speed	3450 RPM	3450 RPM	3450 RPM	3450 RPM
Power Requirement	220V, 1-Ph, 60 Hz	220V/440V, 3-Ph, 60 Hz	220V, 1-Ph, 60 Hz	220V/440V, 3-Ph, 60 Hz
Full Load Current Rating	18	19.5/10	18	19.5/10
Plug/Outlet Type (Recommended)	NEMA L6-30	L15-30/Hardwire	NEMA L6-30	L15-30/Hardwire

Table Size (full assembly)	78¾" x 30¾"	78¾" x 30¾"	30¾" x 48¾"	30¾" x 48¾"
Table Height Above Floor	35¾"	35¾"	35¾"	35¾"
Overall Machine Size	91"L x 79¼"W	91"L x 79¼"W	75"L x 47"W	75"L x 47"W
Footprint Size	22½"L x 24"W	22½"L x 24"W	22½"L x 24"W	22½"L x 24"W
Weight	715 lbs.	715 lbs.	640 lbs.	640 lbs.
Fence Type	T-Shape	T-Shape	T-Shape	T-Shape
Extension & Outfeed Tables	Yes	Yes	No	No

Maximum Rip Right of Blade	52"	52"	36"	36"
Maximum Rip Left of Blade	18"	18"	18"	18"
Maximum Depth of Cut at 90°	4"	4"	4"	4"
Maximum Depth of Cut at 45°	2¾"	2¾"	2¾"	2¾"

Maximum Blade Diameter	12"	12"	12"	12"
Arbor Size	1"	1"	1"	1"
Arbor Speed	3600 RPM	3600 RPM	3600 RPM	3600 RPM
Rim Speed	11,310 FPM	11,310 FPM	11,310 FPM	11,310 FPM
Blade Tilt (Left)	0° – 45°	0° – 45°	0° – 45°	0° – 45°
Maximum Dado Width	¾"	¾"	¾"	¾"
Spreader/Riving Knife Thickness	0.09" (2.3mm)	0.09" (2.3mm)	0.09" (2.3mm)	0.09" (2.3mm)
Required Blade Body Thickness	0.074"–0.082" (1.9–2.1mm)	0.074"–0.082" (1.9–2.1mm)	0.074"–0.082" (1.9–2.1mm)	0.074"–0.082" (1.9–2.1mm)
Required Blade Kerf Thickness	0.114"– 0.122" (2.9mm–3.1mm)	0.114"– 0.122" (2.9mm–3.1mm)	0.114"– 0.122" (2.9mm–3.1mm)	0.114"– 0.122" (2.9mm–3.1mm)

Warranty	1 Year	1 Year	1 Year	1 Year
----------	--------	--------	--------	--------




# SECTION 1: SAFETY

## For Your Own Safety, Read Instruction Manual Before Operating This Machine

The purpose of safety symbols is to attract your attention to possible hazardous conditions. This manual uses a series of symbols and signal words intended to convey the level of importance of the safety messages. The progression of symbols is described below. Remember that safety messages by themselves do not eliminate danger and are not a substitute for proper accident prevention measures. Always use common sense and good judgment.

 **DANGER** Indicates an imminently hazardous situation which, if not avoided, **WILL** result in death or serious injury.

 **WARNING** Indicates a potentially hazardous situation which, if not avoided, **COULD** result in death or serious injury.

 **CAUTION** Indicates a potentially hazardous situation which, if not avoided, **MAY** result in minor or moderate injury. It may also be used to alert against unsafe practices.

**NOTICE** This symbol is used to alert the user to useful information about proper operation of the machine.

## Safety Instructions for Machinery

### **WARNING**

**OWNER'S MANUAL.** Read and understand this owner's manual **BEFORE** using machine.

**TRAINED OPERATORS ONLY.** Untrained operators have a higher risk of being hurt or killed. Only allow trained/supervised people to use this machine. When machine is not being used, disconnect power, remove switch keys, or lock-out machine to prevent unauthorized use—especially around children. Make workshop kid proof!

**DANGEROUS ENVIRONMENTS.** Do not use machinery in areas that are wet, cluttered, or have poor lighting. Operating machinery in these areas greatly increases the risk of accidents and injury.

**MENTAL ALERTNESS REQUIRED.** Full mental alertness is required for safe operation of machinery. Never operate under the influence of drugs or alcohol, when tired, or when distracted.

**ELECTRICAL EQUIPMENT INJURY RISKS.** You can be shocked, burned, or killed by touching live electrical components or improperly grounded machinery. To reduce this risk, only allow qualified service personnel to do electrical installation or repair work, and always disconnect power before accessing or exposing electrical equipment.

**DISCONNECT POWER FIRST.** Always disconnect machine from power supply **BEFORE** making adjustments, changing tooling, or servicing machine. This prevents an injury risk from unintended startup or contact with live electrical components.

**EYE PROTECTION.** Always wear ANSI-approved safety glasses or a face shield when operating or observing machinery to reduce the risk of eye injury or blindness from flying particles. Everyday eyeglasses are **NOT** approved safety glasses.



# WARNING

**WEARING PROPER APPAREL.** Do not wear clothing, apparel or jewelry that can become entangled in moving parts. Always tie back or cover long hair. Wear non-slip footwear to avoid accidental slips, which could cause loss of workpiece control.

**HAZARDOUS DUST.** Dust created while using machinery may cause cancer, birth defects, or long-term respiratory damage. Be aware of dust hazards associated with each workpiece material, and always wear a NIOSH-approved respirator to reduce your risk.

**HEARING PROTECTION.** Always wear hearing protection when operating or observing loud machinery. Extended exposure to this noise without hearing protection can cause permanent hearing loss.

**REMOVE ADJUSTING TOOLS.** Tools left on machinery can become dangerous projectiles upon startup. Never leave chuck keys, wrenches, or any other tools on machine. Always verify removal before starting!

**USE CORRECT TOOL FOR THE JOB.** Only use this tool for its intended purpose—do not force it or an attachment to do a job for which it was not designed. Never make unapproved modifications—modifying tool or using it differently than intended may result in malfunction or mechanical failure that can lead to personal injury or death!

**AWKWARD POSITIONS.** Keep proper footing and balance at all times when operating machine. Do not overreach! Avoid awkward hand positions that make workpiece control difficult or increase the risk of accidental injury.

**CHILDREN & BYSTANDERS.** Keep children and bystanders at a safe distance from the work area. Stop using machine if they become a distraction.

**GUARDS & COVERS.** Guards and covers reduce accidental contact with moving parts or flying debris. Make sure they are properly installed, undamaged, and working correctly.

**FORCING MACHINERY.** Do not force machine. It will do the job safer and better at the rate for which it was designed.

**NEVER STAND ON MACHINE.** Serious injury may occur if machine is tipped or if the cutting tool is unintentionally contacted.

**STABLE MACHINE.** Unexpected movement during operation greatly increases risk of injury or loss of control. Before starting, verify machine is stable and mobile base (if used) is locked.

**USE RECOMMENDED ACCESSORIES.** Consult this owner's manual or the manufacturer for recommended accessories. Using improper accessories will increase the risk of serious injury.

**UNATTENDED OPERATION.** To reduce the risk of accidental injury, turn machine **OFF** and ensure all moving parts completely stop before walking away. Never leave machine running while unattended.

**MAINTAIN WITH CARE.** Follow all maintenance instructions and lubrication schedules to keep machine in good working condition. A machine that is improperly maintained could malfunction, leading to serious personal injury or death.

**CHECK DAMAGED PARTS.** Regularly inspect machine for any condition that may affect safe operation. Immediately repair or replace damaged or mis-adjusted parts before operating machine.

**MAINTAIN POWER CORDS.** When disconnecting cord-connected machines from power, grab and pull the plug—NOT the cord. Pulling the cord may damage the wires inside. Do not handle cord/plug with wet hands. Avoid cord damage by keeping it away from heated surfaces, high traffic areas, harsh chemicals, and wet/damp locations.

**EXPERIENCING DIFFICULTIES.** If at any time you experience difficulties performing the intended operation, stop using the machine! Contact our Technical Support at (570) 546-9663.



# Additional Safety for Table Saws

## **WARNING**

**HAND & BODY POSITIONING.** Touching a spinning saw blade will cause serious laceration or amputation injuries. Keep hands away from saw blade and out of blade path during operation, so they cannot slip accidentally into blade. Stand to side of blade path. Never reach around, behind, or over blade. Only operate at front of machine; never operate from rear or sides of saw.

**BLADE GUARD.** Use blade guard for all “through cuts” for which it can be used. (A through cut is an operation where blade cuts completely through the top of the workpiece.) Make sure the blade guard is installed and adjusted correctly; promptly repair or replace it if damaged. Always re-install blade guard immediately after operations that require its removal. Operating saw with blade guard removed greatly increases risk of severe laceration or amputation injuries from accidental blade contact.

**RIVING KNIFE.** Use the riving knife for all “non-through cuts” for which it can be used. (A non-through cut is an operation where the blade does not cut through the top of the workpiece.) Make sure the riving knife is aligned and positioned correctly; and promptly repair or replace it if damaged. Using the riving knife incorrectly will increase the risk of kickback or accidental blade contact.

**KICKBACK.** Kickback occurs when the saw blade ejects the workpiece back toward the operator. Know how to reduce the risk of kickback, and learn how to protect yourself if it does occur.

**FEEDING WORKPIECE.** Feeding workpiece incorrectly will increase risk of kickback. Never start saw with a workpiece touching blade; allow blade to reach full speed before cutting. Only feed workpiece against direction of blade rotation, from front of saw. Never pull workpiece from behind blade. Always use some type of guide (fence, miter gauge, sliding table or sled, etc.) to feed workpiece in a straight line. Never back a workpiece out of a cut or move it backwards or sideways after starting a cut. Feed cuts all the way through to completion. Never perform any operation “freehand” (making a cut without using a fence, miter gauge, or other guide). Never plunge cut.

**FENCE.** Make sure the fence remains properly adjusted and parallel with the blade. Always lock the fence in place before using. Using or adjusting the fence incorrectly will increase risk of kickback.

**PUSH STICKS/BLOCKS.** Use push sticks or push blocks whenever possible to keep your hands farther away from the blade while cutting; in the event of an accident these devices will often take damage that would have happened to hands/fingers.

**CUT-OFF PIECES.** Never use your hands to move cut-offs away from the blade while the saw is running. If a cut-off becomes trapped between the blade and table insert, turn the saw **OFF** and allow the blade to completely stop before removing it.

**BLADE ADJUSTMENTS.** Adjusting the blade height or tilt during operation increases the risk of crashing the blade and sending metal fragments flying with deadly force at the operator or bystanders. Only adjust the blade height and tilt when the blade is completely stopped and the saw is **OFF**.

**CHANGING BLADES.** Always disconnect power before changing blades. Changing blades while the saw is connected to power greatly increases the injury risk if saw is accidentally powered up.

**DAMAGED SAW BLADES.** Never use blades that have been dropped or otherwise damaged. Damaged blades can fly apart and strike the operator with shards of metal.

**DADO AND RABBET OPERATIONS.** DO NOT attempt dado or rabbeting operations without first reading those sections in this manual. Dado and rabbeting operations require special attention because they must be performed with the blade guard removed.

**CUTTING CORRECT MATERIAL.** Never cut materials not intended for this saw; only cut natural and man-made wood products, laminate covered wood products, and some plastics. Cutting metal, glass, stone, tile, etc. increases the risk of operator injury due to kickback or flying particles.



# Preventing Kickback

---

**Take the precautions below to avoid the most common causes of kickback:**

- Only cut workpieces with at least one smooth and straight edge. DO NOT cut warped, cupped or twisted wood.
- Never attempt freehand cuts. If the workpiece is not fed parallel with the blade, kickback will likely occur. Always use the rip fence or miter gauge to support the workpiece.
- Make sure the spreader or riving knife is aligned with the blade. A misaligned spreader or riving knife can cause the workpiece to catch or bind, increasing the chance of kickback. If you think that your spreader or riving knife is not aligned with the blade, check it immediately!
- Take the time to check and adjust the rip fence parallel with the blade; otherwise, the chances of kickback are extreme.
- The spreader or riving knife maintains the kerf in the workpiece, reducing the chance of kickback. Always use the riving knife for all non-through operations, unless a dado blade is installed. Always use the spreader with the blade guard for all through cuts.
- Feed cuts through to completion. Anytime you stop feeding a workpiece in the middle of a cut, the chance of kickback is greatly increased.
- Keep the blade guard installed and in good working order. Only remove it when performing non-through cuts and immediately re-install the blade guard when finished. Remember, always use the riving knife for all non-through operations, unless a dado blade is installed.
- Make multiple, shallow passes when performing a non-through cut. Making a deep non-through cut will greatly increase the chance of kickback.

- Never move the workpiece backwards or try to back it out of a cut while the blade is moving. If you cannot complete a cut for some reason, stop the saw motor and allow the blade to completely stop before backing the workpiece out. Promptly fix the condition that prevented you from completing the cut before starting the saw again.

## **WARNING**

**Statistics show that most common accidents among table saw users can be linked to kickback. Kickback is typically defined as the high-speed expulsion of stock from the table saw toward its operator. In addition to the danger of the operator or others in the area being struck by the flying stock, it is often the case that the operator's hands are pulled into the blade during the kickback.**

## Protecting Yourself From Kickback

---

**Even if you know how to prevent kickback, it may still happen. Take these precautions to protect yourself if kickback DOES occur:**

- Stand to the side of the blade during every cut. If kickback does occur, the thrown workpiece usually travels directly in front of the blade.
- Wear safety glasses or a face shield. In the event of kickback, your eyes and face are the most vulnerable part of your body.
- Never, for any reason, place your hand behind the blade. Should kickback occur, your hand will be pulled into the blade.
- Use a push stick to keep your hands farther away from the moving blade. If kickback occurs, the push stick will most likely take the damage that your hand would have received.
- Use featherboards or anti-kickback devices to prevent or slow down kickback.



# Glossary of Terms

---

---

The following is a list of common definitions, terms and phrases used throughout this manual as they relate to this table saw and woodworking in general. Become familiar with these terms for assembling, adjusting or operating this machine. Your safety is **VERY** important to us at Grizzly!

**ARBOR:** A metal shaft extending from the drive mechanism that is the mounting location for the saw blade.

**BEVEL EDGE CUT:** A cut made with the blade tilted to an angle between 0° and 45° to cut a beveled edge onto a workpiece. Refer to **Page 42** for more details.

**BLADE GUARD ASSEMBLY:** Metal or plastic safety device that mounts over the saw blade. Its function is to prevent the operator from coming into contact with the saw blade. Refer to **Page 35** for more details.

**CROSSCUT:** Cutting operation in which the crosscut fence is used to cut across the shortest width of the workpiece. Refer to **Page 41** for more details.

**DADO BLADE:** Blade or set of blades that are used to cut grooves and rabbets. The saw and arbor are not intended to safely use a larger dado blade.

**DADO CUT:** Cutting operation that uses a dado blade to cut a flat bottomed groove into the face of the workpiece. Refer to **Page 42** for more details.

**FEATHERBOARD:** Safety device used to keep the workpiece against the rip fence and against the table surface. Refer to **Page 50** for more details.

**KERF:** The resulting cut or gap in the workpiece after the saw blade passes through during a cutting operation.

**KICKBACK:** An event in which the workpiece is propelled back towards the operator at a high rate of speed.

**NON-THROUGH CUT:** A cut in which the blade does not cut through the top of the workpiece. Refer to **Page 32** for more details.

**PARALLEL:** Being an equal distance apart at every point along two given lines or planes (i.e. the rip fence face is parallel to the face of the saw blade).

**PERPENDICULAR:** Lines or planes that intersect and form right angles (i.e. the blade is perpendicular to the table surface).

**PUSH STICK:** Safety device used to push the workpiece through a cutting operation. Used most often when rip cutting thin workpieces. Refer to **Page 53** for more details.

**RABBET:** Cutting operation that creates an L-shaped channel along the edge of the workpiece. Refer to **Page 45** for more details.

**RIP CUT:** Cutting operation in which the rip fence is used to cut across the widest width of the workpiece. Refer to **Page 40** for more details.

**RIVING KNIFE:** Metal plate located behind the blade. It maintains the kerf opening in the wood when performing a cutting operation. Refer to **Page 38** for more details.

**SPREADER:** Metal plate located behind the blade. Maintains kerf opening in wood when performing a cutting operation. Acts as a barrier behind blade to shield hands from being pulled into the blade if kickback occurs.

**STRAIGHTEDGE:** A tool used to check the flatness, parallelism, or consistency of a surface(s).

**THIN KERF BLADE:** A blade with a kerf or thickness that is thinner than a standard blade cannot be used on this saw.

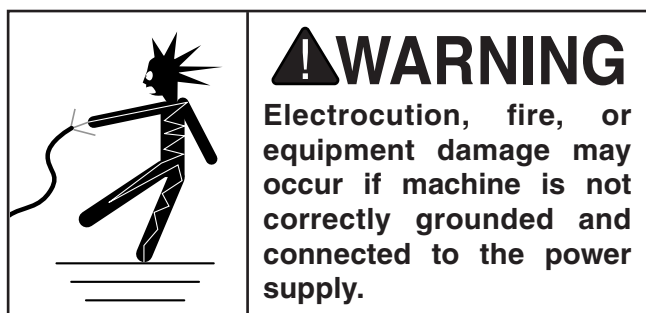
**THROUGH CUT:** A cut in which the blade cuts completely through the workpiece. Refer to **Page 32** for more details.



# SECTION 2: POWER SUPPLY

## Availability

Before installing the machine, consider the availability and proximity of the required power supply circuit. If an existing circuit does not meet the requirements for this machine, a new circuit must be installed. To minimize the risk of electrocution, fire, or equipment damage, installation work and electrical wiring must be done by an electrician or qualified service personnel in accordance with all applicable codes and standards.



## Full-Load Current Rating

The full-load current rating is the amperage a machine draws at 100% of the rated output power. On machines with multiple motors, this is the amperage drawn by the largest motor or sum of all motors and electrical devices that might operate at one time during normal operations.

### G0605X1/G0696X

**Full-Load Current at 220V ..... 18 Amps**

### G0606X1/G0697X

**Full-Load Current at 220V ..... 19.5 Amps**

**Full-Load Current at 440V ..... 10 Amps**

The full-load current is not the maximum amount of amps that the machine will draw. If the machine is overloaded, it will draw additional amps beyond the full-load rating.

If the machine is overloaded for a sufficient length of time, damage, overheating, or fire may result—especially if connected to an undersized circuit. To reduce the risk of these hazards, avoid overloading the machine during operation and make sure it is connected to a power supply circuit that meets the specified circuit requirements.

## Circuit Information

A power supply circuit includes all electrical equipment between the breaker box or fuse panel in the building and the machine. The power supply circuit used for this machine must be sized to safely handle the full-load current drawn from the machine for an extended period of time. (If this machine is connected to a circuit protected by fuses, use a time delay fuse marked D.)

**! CAUTION**  
For your own safety and protection of property, consult an electrician if you are unsure about wiring practices or electrical codes in your area.

**Note:** *Circuit requirements in this manual apply to a dedicated circuit—where only one machine will be running on the circuit at a time. If machine will be connected to a shared circuit where multiple machines may be running at the same time, consult an electrician or qualified service personnel to ensure circuit is properly sized for safe operation.*

## Model G0605X1/G0696X Circuit Requirements for 220V

This machine is prewired to operate on a power supply circuit that has a verified ground and meets the following requirements:

**Nominal Voltage ..... 220V/240V**  
**Phase ..... 1-Phase**  
**Circuit Rating ..... 30 Amps**  
**Plug/Receptacle ..... NEMA L6-30**  
**Cord ..... 3-Wire, 12 AWG, 300VAC, “S”-Type**

## Model G0606X1/G0697X Circuit Requirements for 220V

This machine is prewired to operate on a power supply circuit that has a verified ground and meets the following requirements:

**Nominal Voltage ..... 220V/240V**  
**Phase ..... 3-Phase**  
**Circuit Rating ..... 30 Amps**  
**Plug/Receptacle ..... NEMA L15-30**  
**Cord ..... 4-Wire, 10 AWG, 300VAC, “S”-Type**



## Model G0606X1/G0697X Circuit Requirements for 440V

This machine can be converted to operate on a power supply circuit that has a verified ground and meets the requirements listed below. (Refer to **Voltage Conversion** instructions for details.)

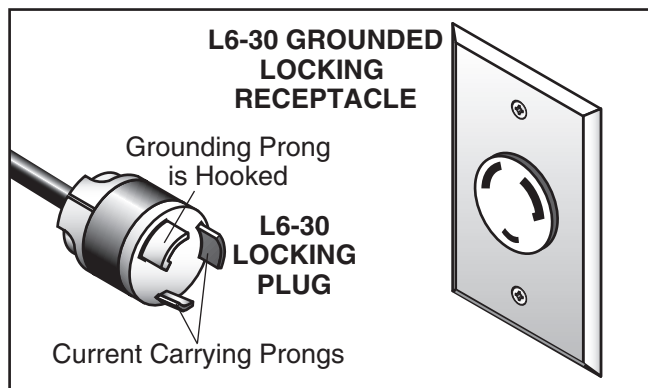
**Nominal Voltage** ..... 440V/480V  
**Cycle**.....60 Hz  
**Phase**..... 3-Phase  
**Circuit Rating**..... 15 Amps  
**Connection**.....Hardwire with Locking Switch

**⚠ WARNING**

Serious injury could occur if you connect the machine to power before completing the setup process. **DO NOT** connect to power until instructed later in this manual.

## Model G0605X1/G0696X Connection Device

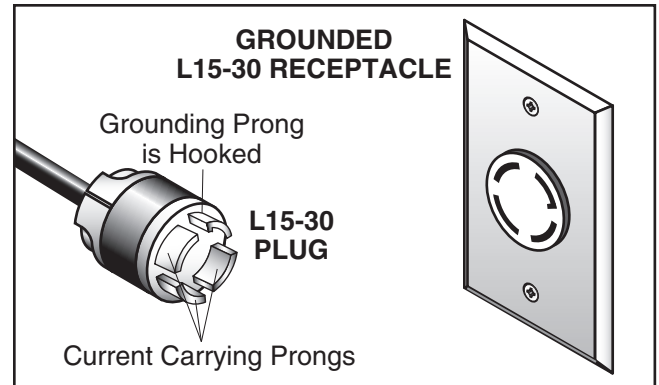
The power cord and plug specified under “Circuit Requirements for 220V” on the previous page has an equipment-grounding wire and a grounding prong. The plug must only be inserted into a matching receptacle (outlet) that is properly installed and grounded in accordance with all local codes and ordinances (see figure below).



**Figure 2.** Typical L6-30 plug and receptacle.

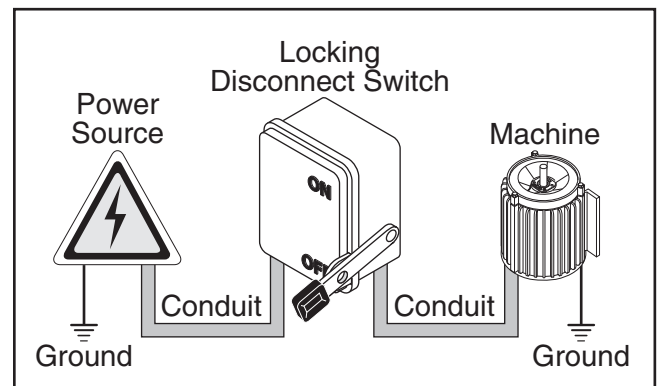
## Model G0606X1/G0697X Connection Device

**For 220V operation:** The power cord and plug specified under “Circuit Requirements for 220V” on the previous page have an equipment-grounding wire and a grounding prong. The plug must only be inserted into a matching receptacle (outlet) that is properly installed and grounded in accordance with all local codes and ordinances (see figure below).



**Figure 3.** Typical L15-30 plug and receptacle.

**For 440V operation:** As specified in “Circuit Requirements for 440V” on the previous page, the machine must be hardwired to the power source, using a locking switch as a disconnecting means (see below). The machine must also be connected to a grounded metal permanent wiring system; or to a system having an equipment-grounding conductor. Due to the complexity and high voltage involved, this type of installation **MUST** be done by a qualified electrician.



**Figure 4.** Typical hardwire setup with a locking disconnect switch.



## Grounding Instructions

This machine **MUST** be grounded. In the event of certain malfunctions or breakdowns, grounding reduces the risk of electric shock by providing a path of least resistance for electric current.

Improper connection of the equipment-grounding wire can result in a risk of electric shock. The wire with green insulation (with or without yellow stripes) is the equipment-grounding wire. If repair or replacement of the power cord or plug is necessary, do not connect the equipment-grounding wire to a live (current carrying) terminal.

Check with a qualified electrician or service personnel if you do not understand these grounding requirements, or if you are in doubt about whether the tool is properly grounded. If you ever notice that a cord or plug is damaged or worn, disconnect it from power, and immediately replace it with a new one.

## Extension Cords (220V Only)

We do not recommend using an extension cord with this machine. If you must use an extension cord, only use it if absolutely necessary and only on a temporary basis.

Extension cords cause voltage drop, which can damage electrical components and shorten motor life. Voltage drop increases as the extension cord size gets longer and the gauge size gets smaller (higher gauge numbers indicate smaller sizes).

Any extension cord used with this machine must be in good condition and contain a ground wire and matching plug/receptacle. Additionally, it must meet the following size requirements:

**Minimum Gauge Size** .....12 AWG  
**Maximum Length (Shorter is Better)**.....50 ft.

## Phase Converter Precaution

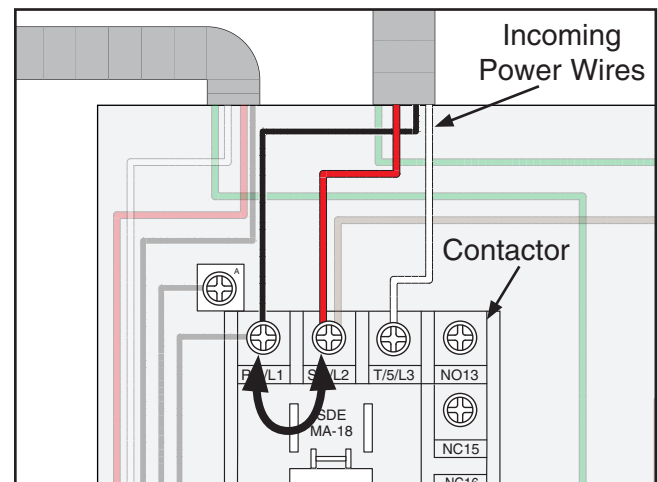
The power from the manufactured leg may damage electrical components if connected to the wrong incoming power terminal on your machine. Only connect the manufactured leg to the **T/5/L3** terminal (see **Page 81** for identification).

# Correcting Phase Polarity

This sub-section is only provided for troubleshooting the Model G0606X1/G0697X. If you discover during the test run that the table saw will not operate, or that the blade runs backwards, the table saw may be wired out of phase. Without the proper test equipment to determine the phase polarity of power source legs, wiring machinery to 3-phase power may require trial-and-error. Correcting this is simply a matter of reversing the positions where two of the incoming power source wires are connected.

### To correct wiring that is out of phase:

1. Push the stop button and disconnect the machine, or shut OFF and lock out the power source if hardwired.
2. Remove the magnetic switch cover and disconnect the L1 and L2 wires, shown in **Figure 5**.



**Figure 5.** Example of switching incoming power wires L1 and L2.

3. Connect the L1 wire to the terminal where the L2 wire was connected originally.
4. Connect the L2 wire to the terminal where the L1 wire was connected originally.
5. Re-install the magnetic switch cover, then reconnect the machine to the power source.



# Voltage Conversion

The Model G0606X1/G0697X can be converted for 440V operation.

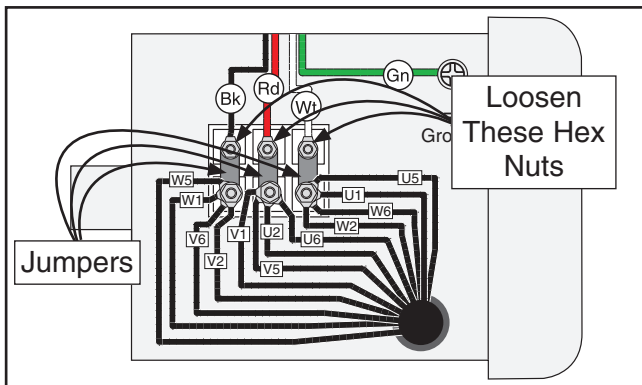
This conversion job consists of disconnecting the saw from the power source, rewiring the motor, switching the transformer fuse from 220V to 440V, and changing the thermal overload relay from 22 to 11 Amps.

## NOTICE

Refer to the motor junction box cover diagram for motor connection locations and voltage conversion. If not present, use the instructions below, or call our Tech Support Department at (570) 546-9663.

## Converting Model G0606X1/G0697X to 440V

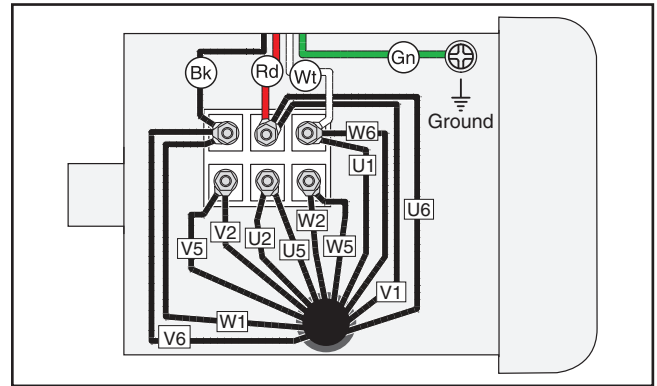
1. DISCONNECT SAW FROM POWER!
2. Open motor cover, remove motor junction box cover, then loosen hex nuts shown in **Figure 6**.



**Figure 6.** Motor prewired to 220V.

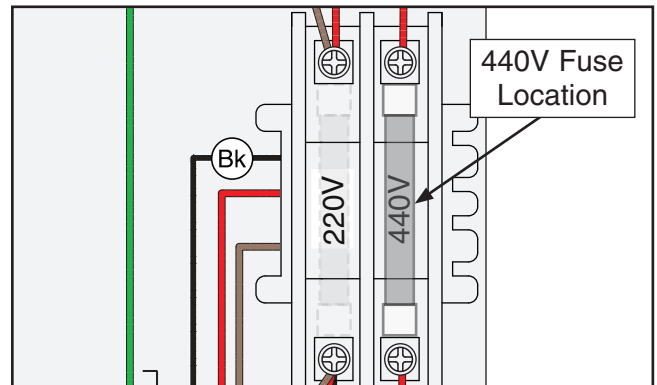
3. Remove three jumpers (they are stacked together), as indicated in **Figure 6**.

4. Rewire motor, as shown in **Figure 7**, tighten hex nuts, then re-install junction box cover.



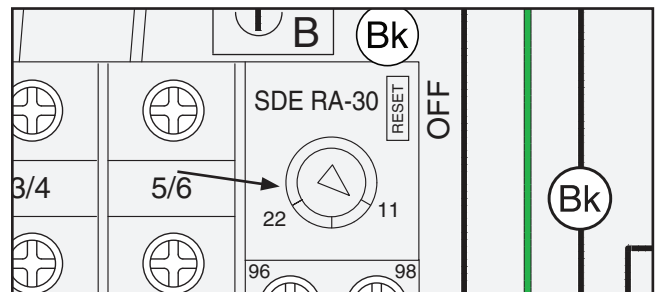
**Figure 7.** Motor rewired to 440V.

5. Remove magnetic switch cover and move fuse on fuse block from 220V slot to 440V slot, as shown in **Figure 8**. (Additionally, refer to photos on **Page 80** and wiring diagram on **Page 82** for further details).



**Figure 8.** Fuse moved from 220V to 440V slot.

6. Turn thermal overload relay dial from 22 amps to 11 amps, as shown in **Figure 9**.

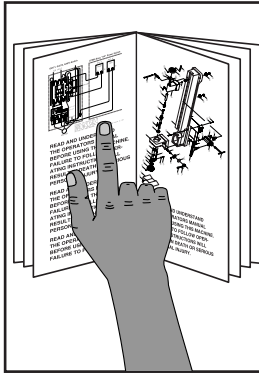


**Figure 9.** Overload relay dial turned to 11 amp setting.

7. Re-install magnetic switch cover and close and secure motor cover.

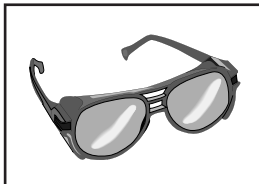


# SECTION 3: SETUP



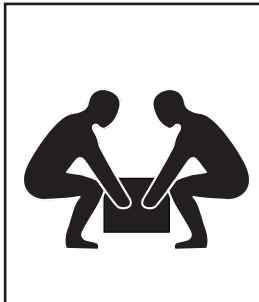
## **!WARNING**

This machine presents serious injury hazards to untrained users. Read through this entire manual to become familiar with the controls and operations before starting the machine!



## **!WARNING**

Wear safety glasses during the entire setup process!



## **!WARNING**

This machine and its components are very heavy. Get lifting help or use power lifting equipment such as a forklift to move heavy items.

## Needed for Setup

The following are needed to complete the setup process, but are not included with your machine:

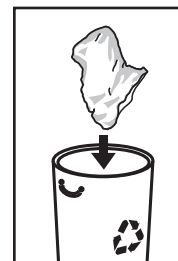
Description	Qty
• Safety Glasses for Each Person .....	1
• Degreaser or Solvent for Cleaning .....	Varies
• Shop Rags for Cleaning .....	Varies
• Forklift.....	1
• Additional People .....	1
• Straightedge 12" (or longer) .....	1
• Straightedge 36" (or longer) .....	1
• Level.....	1
• Open-End Wrench 12mm.....	1
• Dust Collection System .....	1
• Dust Hose 4" .....	1
• Hose Clamp 4" .....	1
• Piece of Scrap Wood (2" Minimum Thickness, Equal to Table Length).....	1
• C-Clamps .....	2

## Unpacking

Your machine was carefully packaged for safe transportation. Remove the packaging materials from around your machine and inspect it. If you discover any damage, *please call us immediately at (570) 546-9663 for advice.*

Save the containers and all packing materials for possible inspection by the carrier or its agent. *Otherwise, filing a freight claim can be difficult.*

When you are completely satisfied with the condition of your shipment, inventory the contents.



## **!WARNING**

### **SUFFOCATION HAZARD!**

Keep children and pets away from plastic bags or packing materials shipped with this machine. Discard immediately.



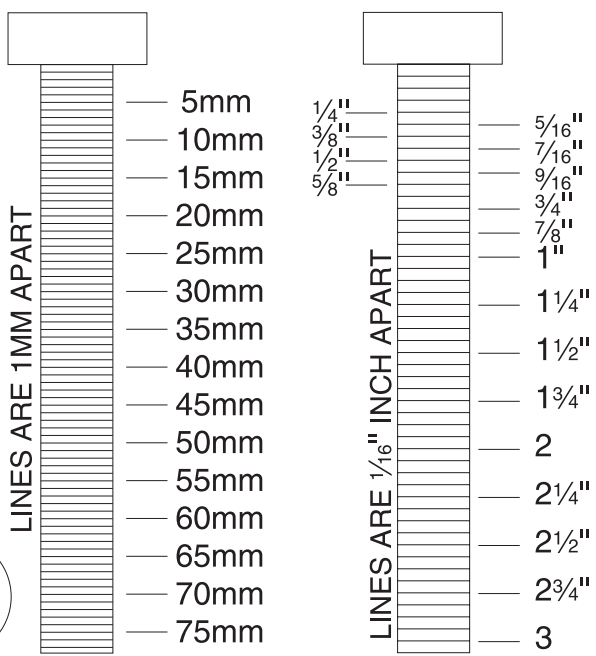
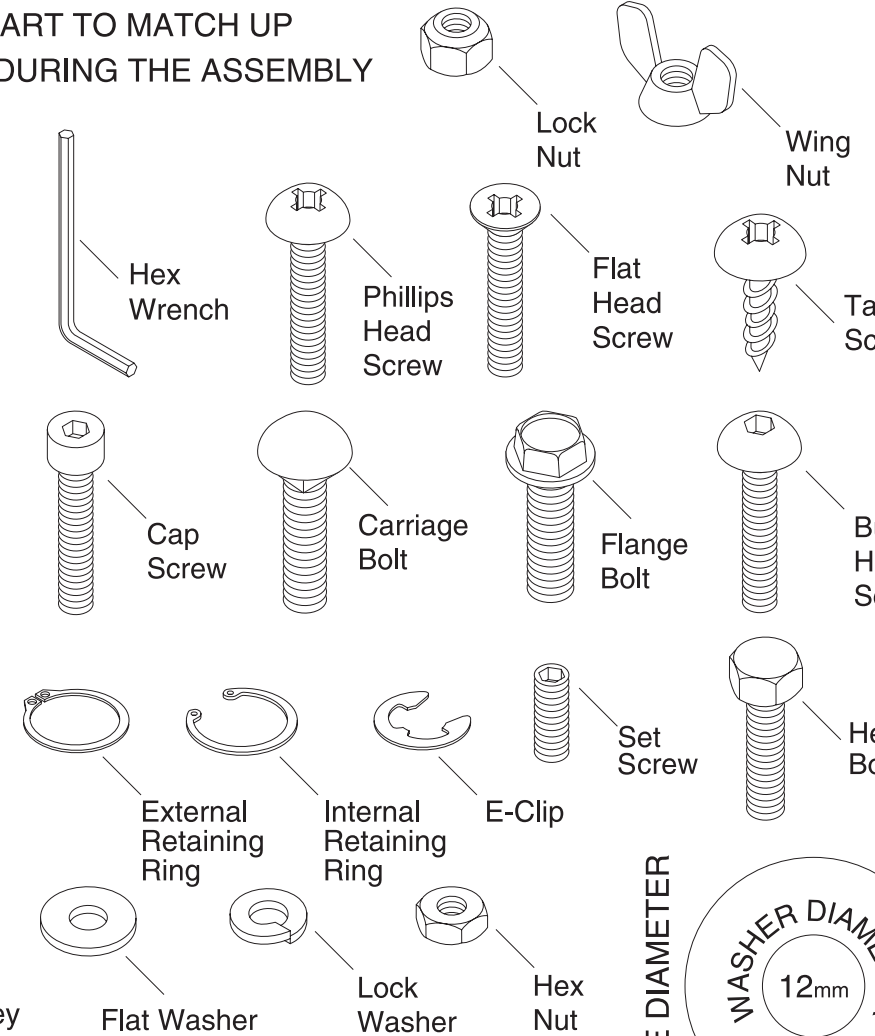
# Hardware Recognition Chart

USE THIS CHART TO MATCH UP HARDWARE DURING THE ASSEMBLY PROCESS.

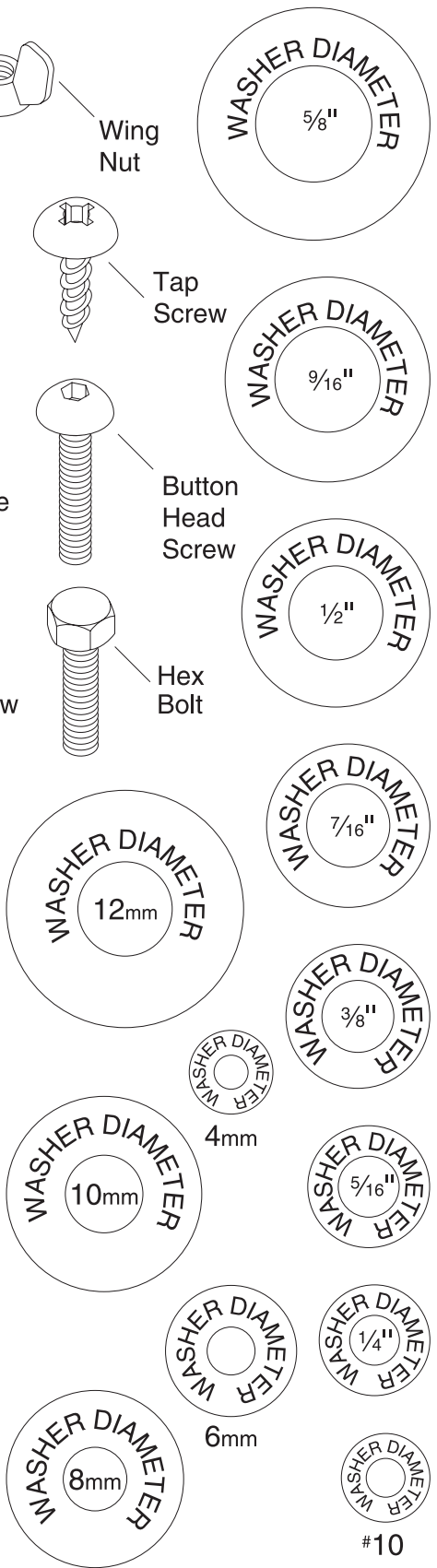
MEASURE BOLT DIAMETER BY PLACING INSIDE CIRCLE

- #10
- 1/4"
- 5/16"
- 3/8"
- 7/16"
- 1/2"

- 4mm
- 6mm
- 8mm
- 10mm
- 12mm
- 16mm



WASHERS ARE MEASURED BY THE INSIDE DIAMETER



# G0605X1/G0606X1 Inventory

The following is a list of items shipped with your machine. Before beginning setup, lay these items out and inventory them.

If any non-proprietary parts are missing (e.g. a nut or a washer), we will gladly replace them; or for the sake of expediency, replacements can be obtained at your local hardware store.

## Table Saw Unit

Box Contents (Figure 10 & 11):	Qty
A. Table Saw Unit (Not Shown) .....	1
B. Spreader/Guard.....	1
C. Push Stick .....	1
D. Miter Gauge.....	1
E. Miter Gauge Handle .....	1
F. Fence Resting Brackets .....	2
G. Handwheel Handles .....	2
H. Arbor Wrenches .....	2
I. Switch Disabling Lock .....	1

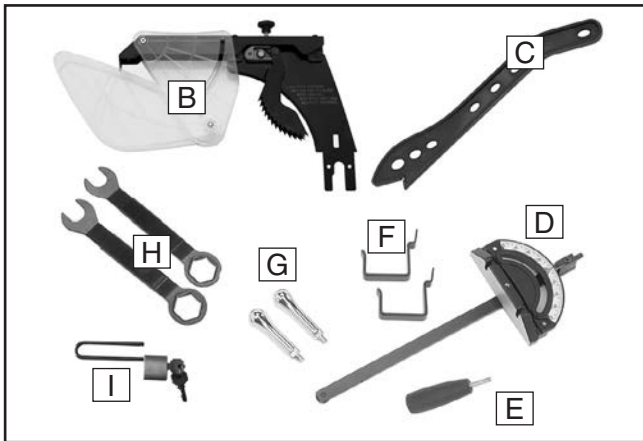


Figure 10. G0605X1 component inventory.

J. Blade 12" .....	1
--------------------	---



Figure 11. Saw blade.

## NOTICE

If you cannot find an item on this list, carefully check around/inside the machine and packaging materials. Often, these items get lost in packaging materials while unpacking or they are pre-installed at the factory.

## Fence Inventory

Box Contents: (Figure 12)	Qty
A. Fence .....	1
B. Fence Handle .....	1

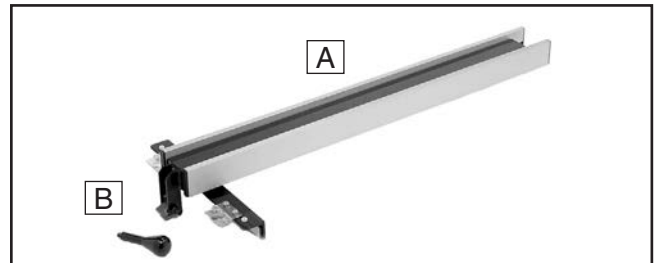


Figure 12. Fence components.

## Fence Rail Inventory

Box Contents: (Figure 13)	Qty
A. Fence Tube (91 <sup>3</sup> / <sub>8</sub> " Long).....	1
B. Front Rail (91 <sup>1</sup> / <sub>8</sub> " Long).....	1
C. Rear Rail (79" Long).....	1



Figure 13. Fence rail components.

Hardware and Tools (Not Shown):	Qty
• Flat Washer 8mm (Miter Gauge).....	1
• Flange Bolts M8-1.25 x 12 (Fence Resting Bracket).....	2
• Flange Bolts M8-1.25 x 12 (Switch).....	2
• Open-End Combo Wrenches 8 x 10, 11 x 13, 14 x 17.....	1 Each
• Hex Wrenches 3, 4, 5, 6mm.....	1 Each
• Combo Screwdriver .....	1
• Lock Knob M5-.8 (Insert).....	1
• Wire Nuts .....	3



## Extension Table Inventory

Box Contents: (Figure 14)	Qty
A. Extension Table.....	1
B. Lower Shelf .....	1
C. Shelf End Plate.....	1
D. Support Legs.....	2
E. Lower Shelf Brackets .....	2

### Hardware and Tools (Not Shown): Qty

- Cap Screws M8-1.25 x 25  
(Rear Rail/Cabinet) ..... 8
- Lock Washers 8mm  
(Rear Rail/Ext. Table) ..... 10
- Flat Head Screws M8-1.25 x 25  
(Front Rail/Cabinet) ..... 8
- Flat Washers 8mm  
(Front Rail/Ext. Table/Rear Rail) ..... 14
- Hex Nuts M8-1.25  
(Front Rail/Ext. Table/Rear Rail) ..... 8
- Flange Bolts M8-1.25 x 12  
(Tube/ Front Rail)..... 9
- Hex Bolts M6-1 x 12  
(Brackets/Cabinet/Legs) ..... 4
- Hex Nuts M6-1  
(Brackets/Cabinet) ..... 2
- Feet  $\frac{3}{8}$ "-16 x 2 (Legs)..... 2
- Phillip Head Screws M6-1 x 12  
(Ext. Table/Legs/End Plate)..... 12
- Flat Washers 6mm  
(Ext Table/Legs/End Plate)..... 16
- Hex Nuts  $\frac{3}{8}$ "-16 (Feet)..... 2
- Flat Washers 10mm (Cabinet)..... 2
- Hex Bolts M10-1.5 x 25 (Cabinet)..... 2
- Flange Bolts M8-1.25 x 12  
(Fence Resting Brackets) ..... 2

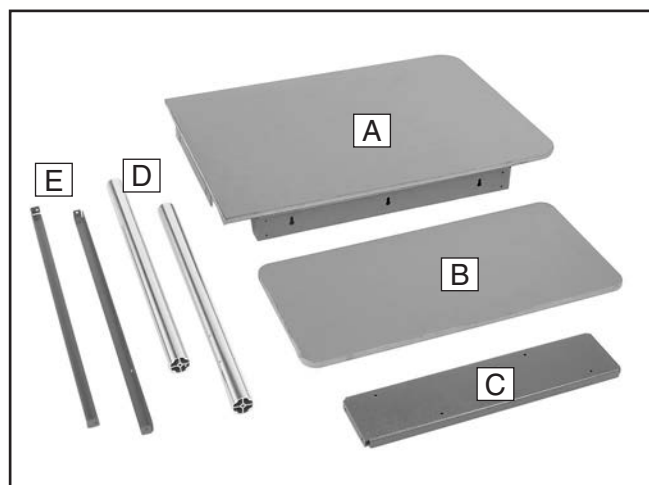


Figure 14. Extension table components.

## Outfeed Table Inventory

Box Contents: (Figure 15)	Qty
A. Outfeed Table.....	1
B. Lower Shelf .....	1
C. Shelf End Plate.....	1
D. Support Legs.....	2
E. Lower Shelf Brackets .....	2

### Hardware and Tools (Not Shown): Qty

- Flange Bolts M8-1.25 x 16  
(Rear Rail/Ext. Table) ..... 2
- Hex Nuts M8-1.25 (Rear Rail/Ext. Table) ... 2
- Hex Bolts M6-1 x 12  
(Brackets/Legs/Cabinet) ..... 4
- Hex Nuts M6-1 (Bracket/Legs/Cabinet)..... 2
- Hex Nuts  $\frac{3}{8}$ "-16 (Brackets/Legs/Cabinet)... 2
- Flat Washers 6mm  
(Brackets/Legs/Cabinet) ..... 16
- Phillips Head Screws M6-1 x 12  
(Legs/Ext. Table/End Plate)..... 12
- Feet  $\frac{3}{8}$ "-16 x 2 (Legs)..... 2

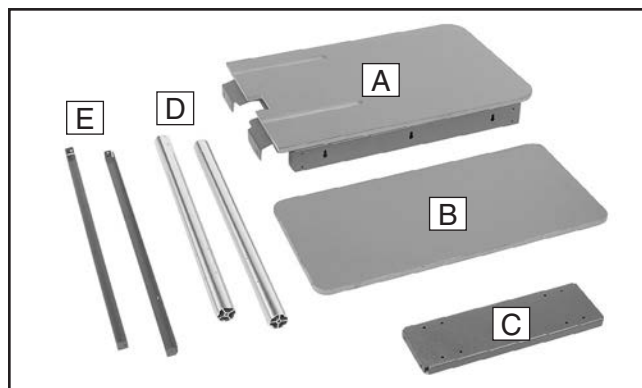


Figure 15. Outfeed table components.



# G0696X/G0697X Inventory

## Table Saw Unit

Box Contents (Figures 16, 17, 18):	Qty
A. Table Saw Unit .....	1
B. Cast Iron Extension Wing.....	1
C. Spreader/Guard For 12" Blade .....	1
D. Push Stick .....	1
E. Miter Gauge.....	1
F. Miter Gauge Handle .....	1
G. Fence Resting Brackets .....	2
H. Handwheel Handles .....	2
I. Switch Disabling Lock .....	1
J. Arbor Wrenches .....	2
K. Blade 12" .....	1

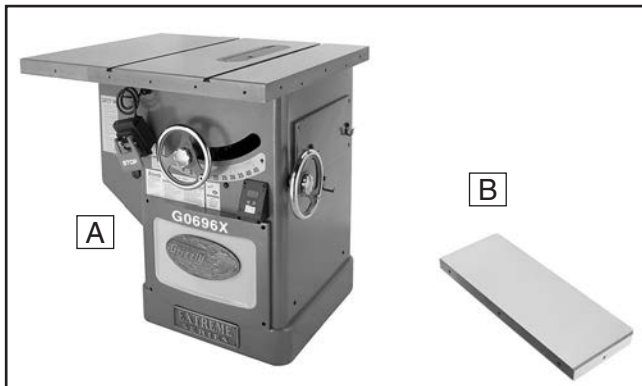


Figure 16. G0696X table saw unit.

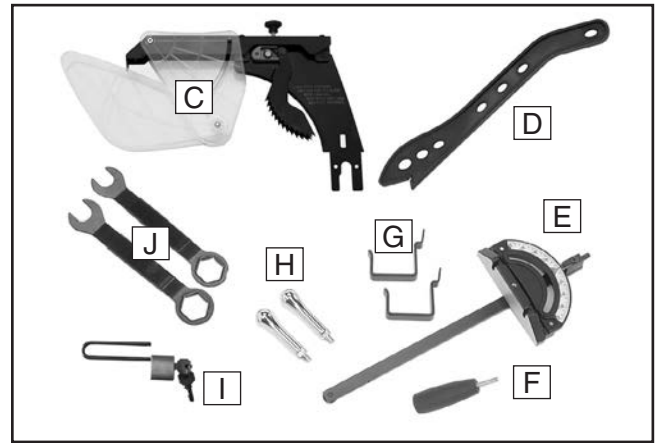


Figure 17. Main components.



Figure 18. Saw blade.

Hardware and Tools (Not Shown):	Qty
• Flat Washer 8mm (Miter Gauge).....	1
• Flange Bolts M8-1.25 x 12 (Fence Resting Bracket).....	2
• Flange Bolts M8-1.25 x 12 (Switch).....	2
• Open-End Combo Wrenches 8 x 10, 11 x 13, 14 x 17.....	1 Each
• Hex Wrenches 3, 4, 5, 6mm.....	1 Each
• Combo Screwdriver .....	1
• Lock Knob M5-.8 (Insert).....	1
• Wire Nuts .....	4



## Fence

Box Contents: (Figure 19)	Qty
A. Fence .....	1
B. Fence Handle .....	1

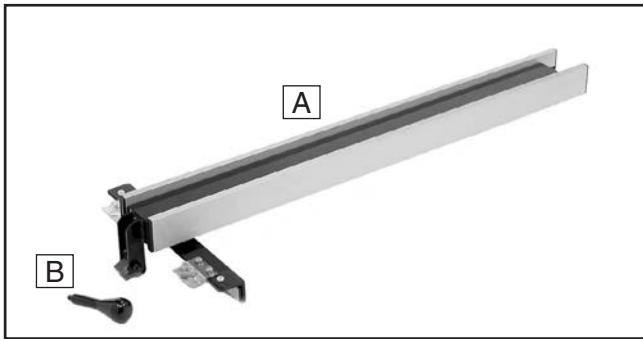


Figure 19. Fence components.

## Hardware and Tools (Not Shown): Qty

- Cap Screws M8-1.25 x 25  
(Rear Rail/Cabinet/Ext. Table)..... 6
- Flat Washers 8mm (Rear Rail/Ext. Table).. 6
- Flat Head Screws M8-1.25 x 25  
(Front Rail/Cabinet/Ext. Table) ..... 6
- Hex Nuts M8-1.25  
(Front Rail & Rear Rails/Ext. Table) ..... 4
- Lock Washers 8mm  
(Front & Rear Rails/Ext. Table) ..... 10
- Flange Bolts M8-1.25 x 12  
(Fence Tube/Front Rail)..... 4
- Hex Bolts M10-1.5 x 35 (Ext. Table)..... 3
- Lock Washers 10mm (Ext. Table) ..... 3
- Flange Bolts M8-1.25 x 12  
(Fence Resting Brackets) ..... 2

## Fence Rail Inventory

Box Contents: (Figure 20)	Qty
A. Fence Tube (75" Long).....	1
B. Front Rail (75" Long) .....	1
C. Rear Rail (62½" Long).....	1



Figure 20. Fence rail components.



# Cleanup

The unpainted surfaces of your machine are coated with a heavy-duty rust preventative that prevents corrosion during shipment and storage. This rust preventative works extremely well, but it will take a little time to clean.

Be patient and do a thorough job cleaning your machine. The time you spend doing this now will give you a better appreciation for the proper care of your machine's unpainted surfaces.

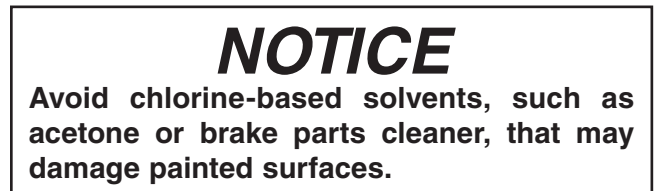
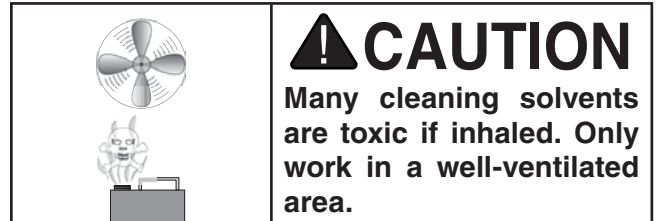
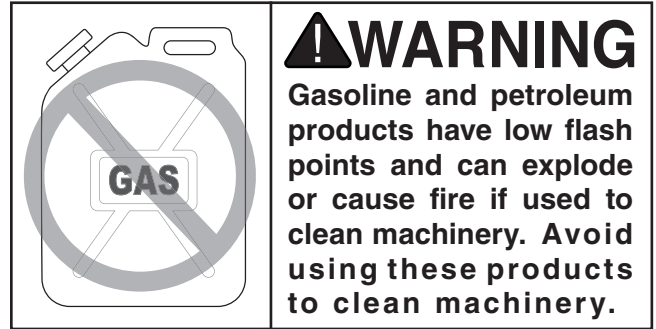
There are many ways to remove this rust preventative, but the following steps work well in a wide variety of situations. Always follow the manufacturer's instructions with any cleaning product you use and make sure you work in a well-ventilated area to minimize exposure to toxic fumes.

## Before cleaning, gather the following:

- Disposable rags
- Cleaner/degreaser (WD•40 works well)
- Safety glasses & disposable gloves
- Plastic paint scraper (optional)

## Basic steps for removing rust preventative:

1. Put on safety glasses.
2. Coat the rust preventative with a liberal amount of cleaner/degreaser, then let it soak for 5–10 minutes.
3. Wipe off the surfaces. If your cleaner/degreaser is effective, the rust preventative will wipe off easily. If you have a plastic paint scraper, scrape off as much as you can first, then wipe off the rest with the rag.
4. Repeat **Steps 2–3** as necessary until clean, then coat all unpainted surfaces with a quality metal protectant to prevent rust.



# Site Considerations

## Weight Load

Refer to the **Machine Data Sheet** for the weight of your machine. Make sure that the surface upon which the machine is placed will bear the weight of the machine, additional equipment that may be installed on the machine, and the heaviest workpiece that will be used. Additionally, consider the weight of the operator and any dynamic loading that may occur when operating the machine.

## Space Allocation

Consider the largest size of workpiece that will be processed through this machine and provide enough space around the machine for adequate operator material handling or the installation of auxiliary equipment. With permanent installations, leave enough space around the machine to open or remove doors/covers as required by the maintenance and service described in this manual. **See below for required space allocation.**

	<p><b>CAUTION</b></p> <p>Children or untrained people may be seriously injured by this machine. Only install in an access restricted location.</p>
---	--

## Physical Environment

The physical environment where the machine is operated is important for safe operation and longevity of machine components. For best results, operate this machine in a dry environment that is free from excessive moisture, hazardous chemicals, airborne abrasives, or extreme conditions. Extreme conditions for this type of machinery are generally those where the ambient temperature range exceeds 41°–104°F; the relative humidity range exceeds 20%–95% (non-condensing); or the environment is subject to vibration, shocks, or bumps.

## Electrical Installation

Place this machine near an existing power source. Make sure all power cords are protected from traffic, material handling, moisture, chemicals, or other hazards. Make sure to leave enough space around machine to disconnect power supply or apply a lockout/tagout device, if required.

## Lighting

Lighting around the machine must be adequate enough that operations can be performed safely. Shadows, glare, or strobe effects that may distract or impede the operator must be eliminated.

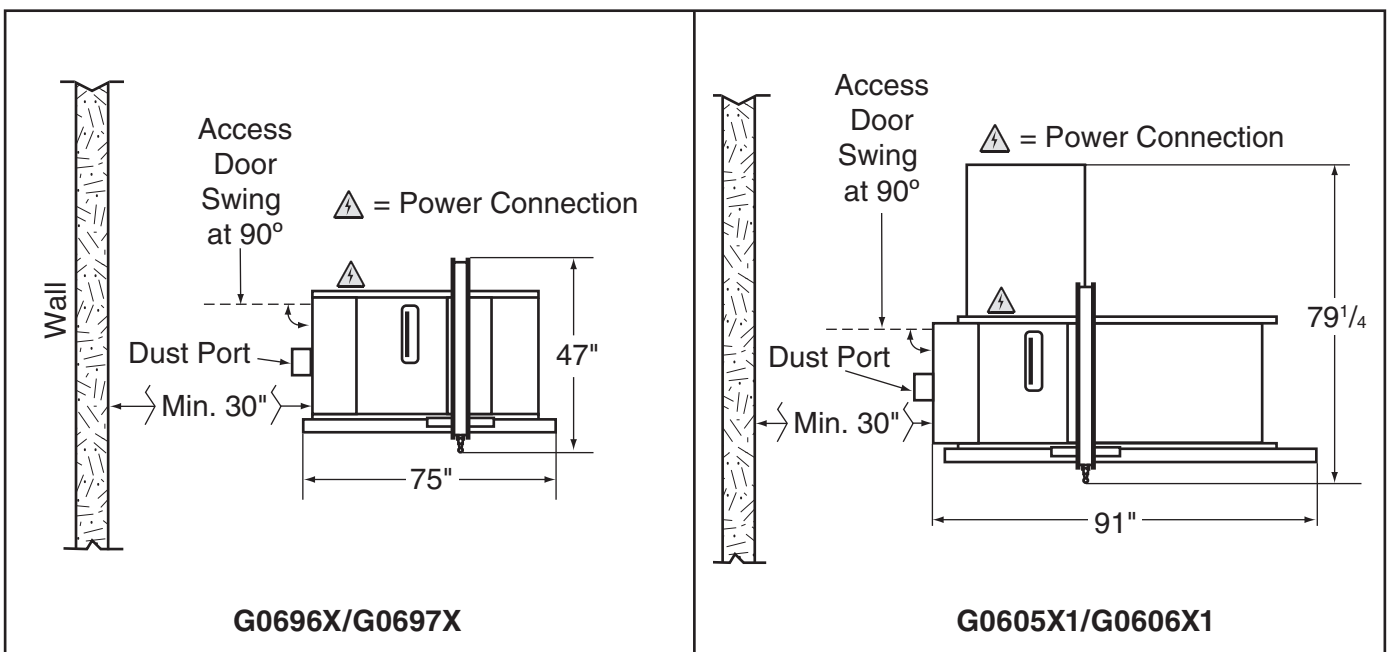


Figure 21. Minimum working clearances.

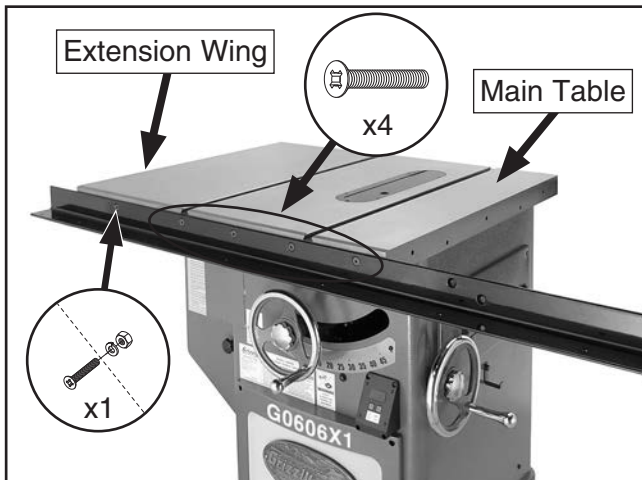


# Assembly

Assembly steps are the same for all models except where noted. Assembly consists of installing the front and rear rails, attaching the extension wing (Model G0696X/G0697X) or extension table and outfeed table (Model G0605X1/G0606X1), then installing minor components.

## To assemble the table saw:

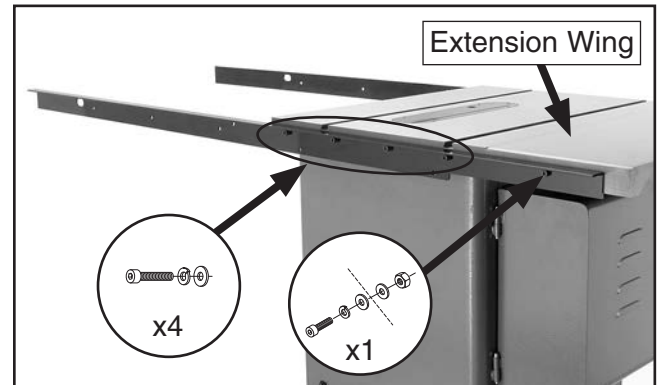
1. Fasten the front rail onto the main table with (4) M8-1.25 x 25 flat head screws, as shown in **Figure 22**.



**Figure 22.** Front rail installed (Model G0605X1 shown).

2. Secure the left side of the front rail to the pre-installed extension wing with (1) M8-1.25 x 25 flat head screw, 8mm lock washer, and M8-1.25 hex nut (see **Figure 22**).

3. Fasten the rear rail to the table with (4) M8-1.25 x 25 cap screws, 8mm lock washers, and 8mm flat washers, as shown in **Figure 23**.



**Figure 23.** Rear rail installed (Model G0605X1 shown).

4. Fasten the right end of the rail to the pre-installed extension wing shown in **Figure 23** with (1) M8-1.25 x 25 cap screw, (2) 8mm lock washers, (1) 8mm flat washer, and (1) M8-1.25 hex nut.

—If you are assembling the G0696X or G0697X, continue to the **G0696X/G0697X Extension Wing** instructions below.

—If you are assembling the G0605X1 or G0606X1, follow the instructions for installing the extension table (**Page 23**) and outfeed table (**Page 24**).

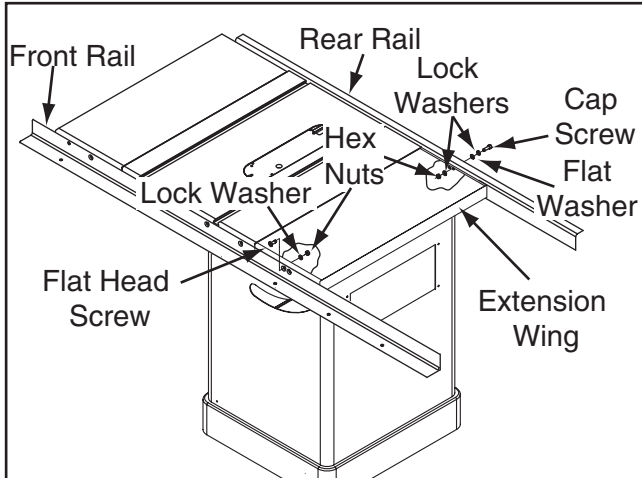
## G0696X/G0697X Extension Wing

1. Inspect the extension wing and main table mating surfaces for burrs or foreign materials that may inhibit assembly.

The mating edges of the wing and the table must be clean, smooth, and flat. Use a wire brush or file if necessary to clean up the edges. This step will ensure that the wing mounts properly to the main table.

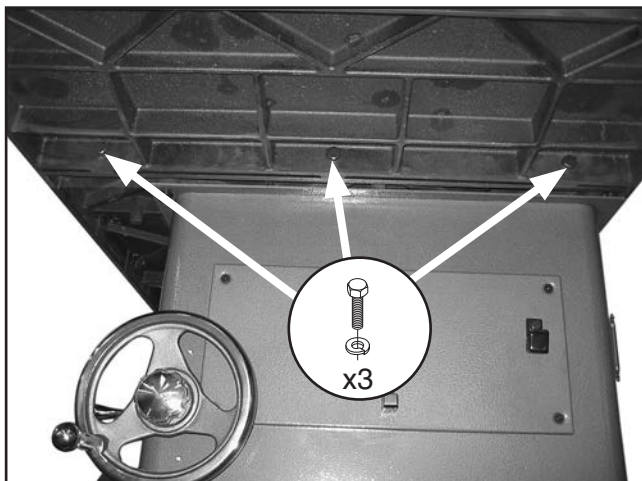


2. With the assistance of a helper, place the extension wing between the rails, and fasten the wing to the front rail with (1) M8-1.25 x 25 flat head screw, 8mm lock washer, and M8-1.25 hex nut (see **Figure 24**). Finger tighten for now.



**Figure 24.** Extension wing attached to Model G0696X/G0697X.

3. Attach the extension wing to the rear rail with (1) M8-1.25 x 25 cap screw, (2) 8mm lock washers, (1) 8mm flat washer and (1) M8-1.25 hex nut, as shown in **Figure 24**. Finger tighten for now.
4. Attach the cast iron wing to the main table with (3) M10-1.5 x 35 hex bolts and 10mm lock washers, as shown in **Figure 25**. Finger tighten for now.

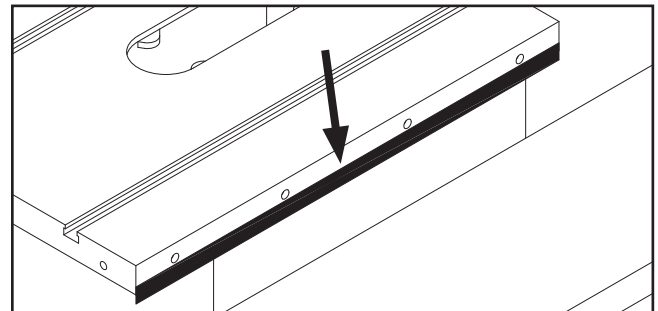


**Figure 25.** Extension wing installed.

5. Use a straightedge as a gauge and adjust the extension wing up/down until it is flush with the main table above each bolt, then completely tighten all the bolts.
6. Place the long straightedge across the extension wings and main table to make sure that the combined table surface is flat.

—If the combined table surface is flat, skip to the next step.

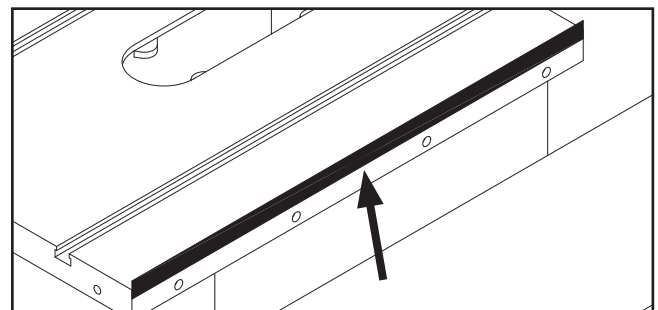
—If the outside end of the extension wing tilts down, use a strip of masking tape along the bottom edge of the main table to shim the extension wing up (see **Figure 26**).



**Figure 26.** Masking tape location for tilting the extension wing up.

—If the outside end of the extension wing tilts up, use a strip of masking tape along the top edge of the main table to shim the extension wing down (see **Figure 27**).

**Note:** After re-installing wings, remove all excess masking tape with a razor blade.



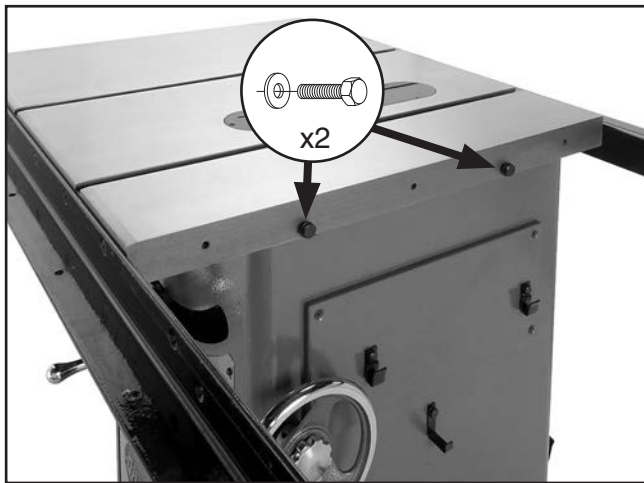
**Figure 27.** Masking tape location for adjusting the extension wing down.

7. Follow the ON/OFF Switch instructions on **Page 25**.



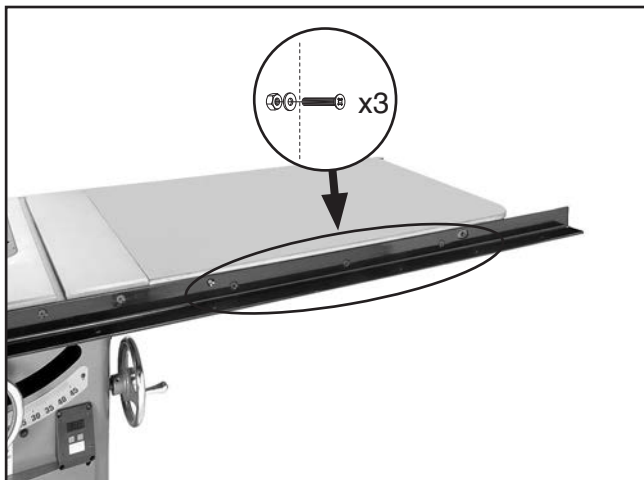
## G0605X1/G0606X1 Extension Table

1. Thread (2) M10-1.5 x 25 hex bolts with 10mm flat washers onto the right side of the main table, as shown in **Figure 28**. Do not fully tighten the bolts.



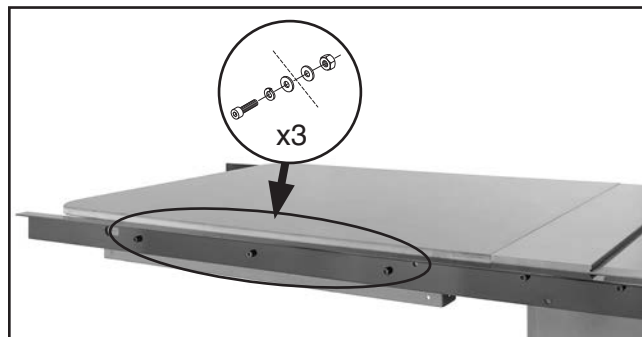
**Figure 28.** Hex bolts installed.

2. With the help of an assistant, place the extension table between the rails and slide the table slots over the bolts installed in **Step 1**.
3. While an assistant holds the extension table, fasten the front rail to the extension table with (3) M8-1.25 x 25 flat head screws, 8mm flat washers and M8-1.25 hex nuts (see **Figure 29**). Finger tighten the hex nuts for now.



**Figure 29.** Front rail/table fastener locations.

4. Fasten the rear rail to the extension table with (3) M8-1.25 x 25 cap screws, (3) 8mm lock washers, (6) 8mm flat washers, and (3) M8-1.25 hex nuts, as shown in **Figure 30**. Finger tighten the hex nuts for now.



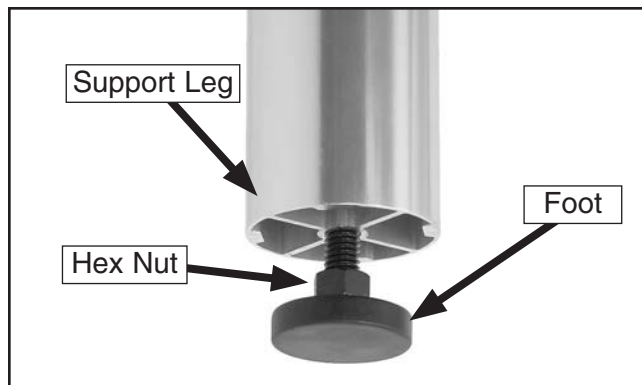
**Figure 30.** Rear rail/table fastener locations.

5. Align the main table and extension table with a straightedge, as shown in **Figure 31**, then tighten all of the mounting fasteners.



**Figure 31.** Aligning main extension table.

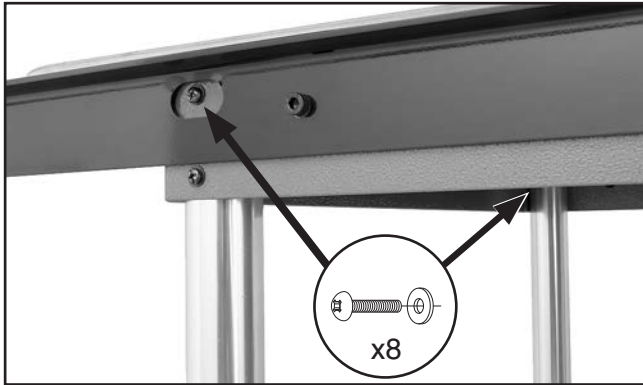
6. Thread a  $\frac{3}{8}$ "-16 hex nut onto each foot, then thread the feet into the bottom of the support legs, as shown in **Figure 32**.



**Figure 32.** Foot installed on support leg.

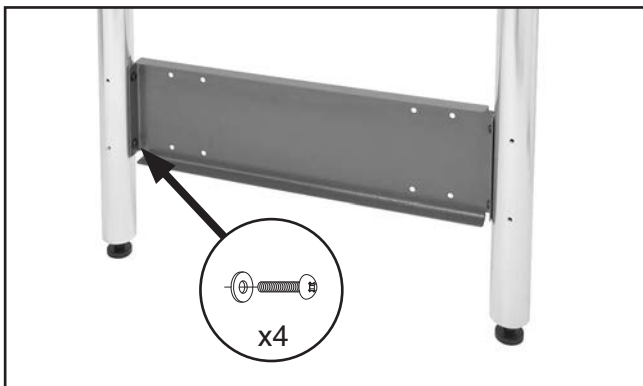


- Fasten the support legs to the main extension table with (8) M6-1 x 12 Phillips head screws and 6mm flat washers (see **Figure 33**).



**Figure 33.** Support leg fastened to main extension table.

- Rotate both feet until they touch the ground, and tighten the hex nuts against the legs to secure the feet.
- Fasten the shelf end plate to the legs with (4) M6-1 x 12 Phillips head screws and 6mm flat washers, as shown in **Figure 34**.

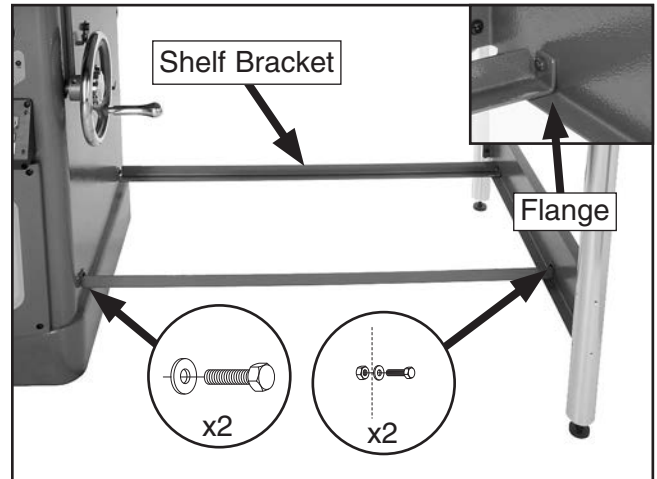


**Figure 34.** Installing shelf end plate on extension table legs.

- Place the shelf brackets between the cabinet and support legs, and fasten with (4) M6-1 x 12 hex bolts, (4) 6mm flat washers and (2) M6-1 hex nuts, as shown in **Figure 35**.

**Note:** The flange on the shelf bracket must point up to ensure proper installation.

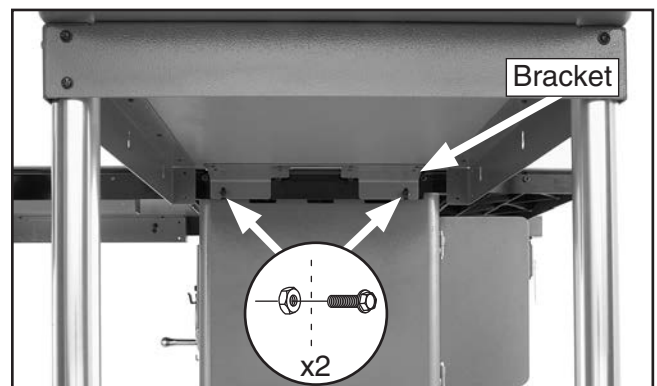
- Place the lower shelf on the brackets.



**Figure 35.** Shelf brackets installed.

### G0605X1/G0606X1 Outfeed Table

- Turn the outfeed table upside down and place it on a level surface.
- Install the feet, support legs, and shelf end plate in the same manner as described in **Extension Table** instructions on **Page 23**.
- Place the extension table assembly upright with the feet on the ground, align the slots in the extension table bracket with the rear rail mounting holes, then fasten the table to the rail with (2) M8-1.25 x 16 flange bolts and M8-1.25 hex nuts, as shown in **Figure 36**.

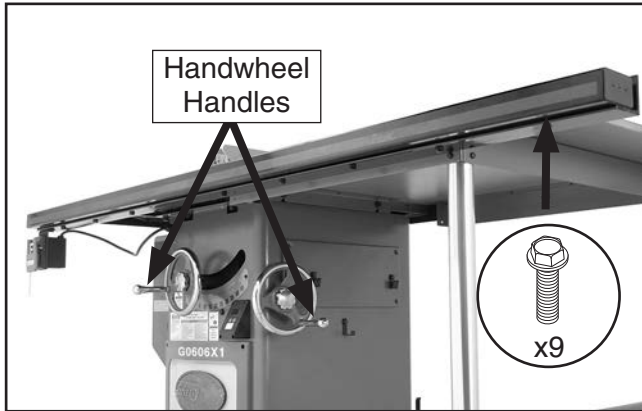


**Figure 36.** Outfeed table fastened to rear rail.

- Secure the lower shelf brackets to the support legs and cabinet with (4) M6-1 x 12 hex bolts, (4) 6mm flat washers, and (2) M6-1 hex nuts.
- Install the lower shelf on the brackets.



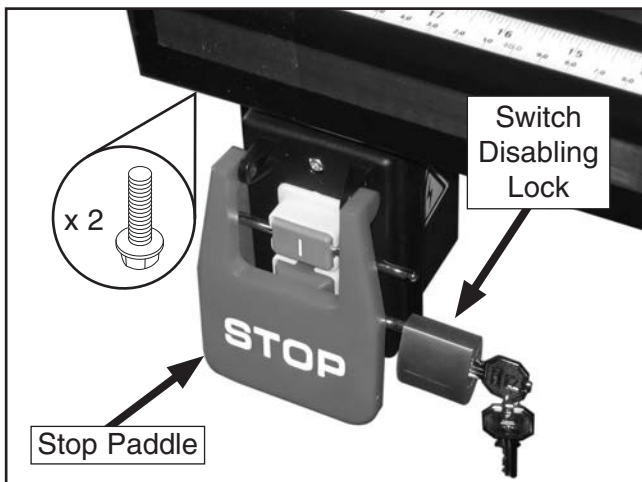
- Place the 91<sup>3</sup>/<sub>8</sub>" fence tube over the 91<sup>1</sup>/<sub>4</sub>" front rail, secure with (9) M8-1.25 x 12 flange bolts, as shown in **Figure 37**, then install the handwheel handles.



**Figure 37.** Fence tube mounted to front fence rail.

### On/Off Switch and Blade

- Fasten the switch to the left end of the front rail with (2) M8-1.25 x 12 flange bolts, then insert the switch disabling lock, as shown in **Figure 38**.



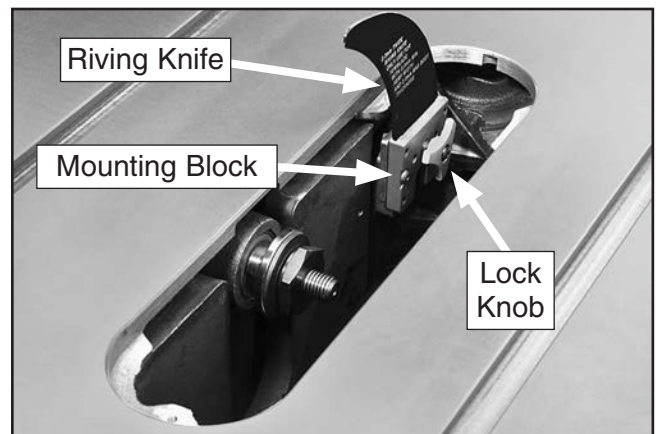
**Figure 38.** Switch installed.

- Turn the lock knob that secures the table insert so it is parallel to the inner slot, as shown in **Figure 39**, then remove the insert and set it aside.



**Figure 39.** Insert lock knob unlocked.

- Raise the arbor all the way up and set the arbor angle to 0°.
- Unthread the lock knob on the riving knife/blade guard mounting block (**Figure 40**) several turns. Push the riving knife away from the knob, then lift the riving knife up to remove it.



**Figure 40.** Riving knife installed.

**Note:** The riving knife is installed for shipping purposes. Two pins in the mounting block insert into matching slots on the riving knife, keeping it secured.

- Install the saw blade as outlined in **Blade Installation** on **Page 34**.

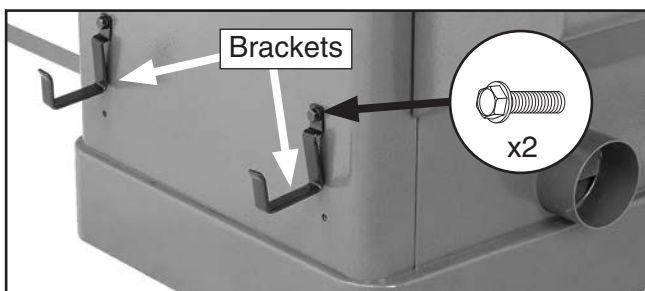


- Install the fence knob as shown in **Figure 41**, and mount the fence on the front rail, to the right of the blade.



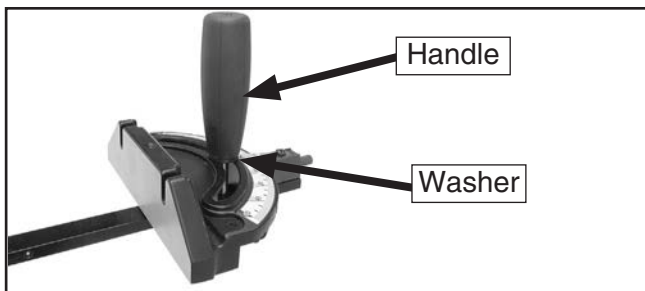
**Figure 41.** Fence knob installed.

- Install the fence resting brackets (**Figure 42**) onto the back of the cabinet with the two M8-1.25 x 12 flange bolts.



**Figure 42.** Fence resting brackets installed.

- Install the handle with 8mm flat washer onto the miter gauge, as shown in **Figure 43**.



**Figure 43.** Miter gauge installed.

- Slide the miter gauge into the T-slot on the left side of the blade; or store it on the brackets near the blade angle handwheel.
- Follow the instructions in **Dust Collection, Power Connection** and **Test Run**, then proceed to **Final Setup** to complete the remaining assembly steps.

## Dust Collection

### ⚠ CAUTION

**DO NOT** operate the Model G0605X1/G0606X1/G0696X/G0697X without an adequate dust collection system. This saw creates substantial amounts of wood dust while operating. Failure to use a dust collection system can result in short and long-term respiratory injury.

**Components and Hardware Needed:**

	<b>Qty</b>
Dust Hose 4" (not included) .....	1
Hose Clamps 4" (not included) .....	2
Dust Collection System (not included) .....	1

### **Recommended CFM at Dust Port: 400 CFM**

*Do not confuse this CFM recommendation with the rating of the dust collector. To determine the CFM at the dust port, you must consider these variables: (1) CFM rating of the dust collector, (2) hose type and length between the dust collector and the machine, (3) number of branches or wyes, and (4) amount of other open lines throughout the system. Explaining how to calculate these variables is beyond the scope of this manual. Consult an expert or purchase a good dust collection "how-to" book.*

### To connect a dust collection hose:

- Fit a 4" dust hose over the dust port, as shown in **Figure 44**, and tightly secure it in place with a hose clamp.



**Figure 44.** Dust hose attached to dust port.

- Tug the hose to make sure it does not come off. **Note:** A tight fit is necessary for proper performance.

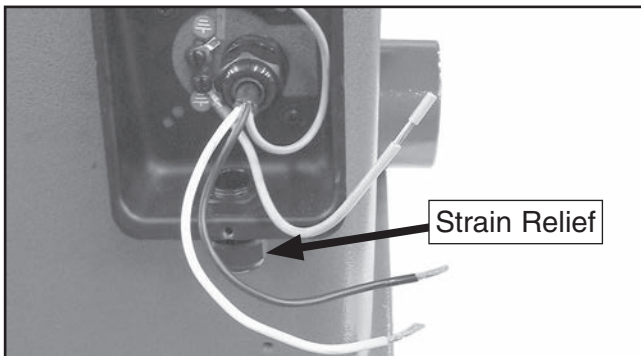


# Power Connection

Before the machine can be connected to the power source, an electrical circuit must be made available that meets the minimum specifications given in "Circuit Requirements for 220V" on **Page 10**. If a power circuit has not been prepared for the machine, do that now. To ensure a safe and code-compliant setup, we strongly recommend that all electrical work be done by a qualified electrician.

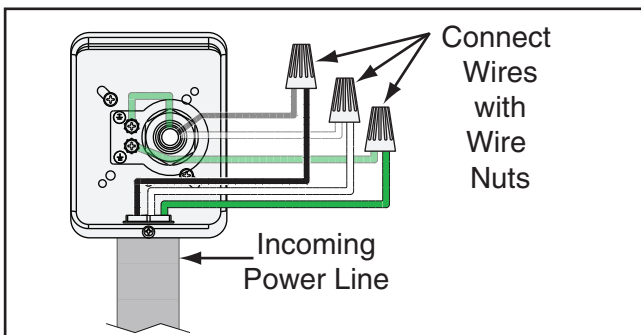
## G0605X1/G0606X1/G0696X/G0697X 220V Power Connection

1. Remove the junction box cover on the rear of the cabinet.
2. Loosen the strain relief on the bottom of the junction box shown in **Figure 45**, then insert the incoming power wires into the junction box.

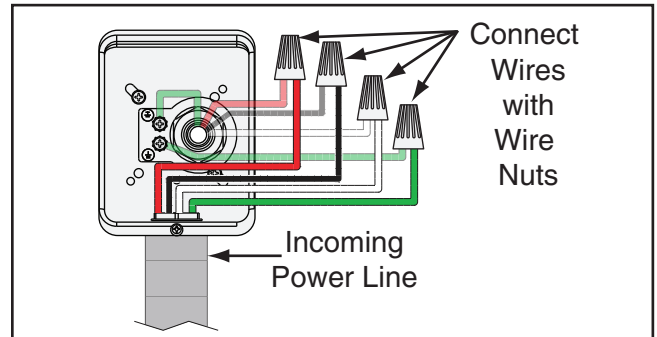


**Figure 45.** Power connection junction box.

3. Connect the incoming power wires and ground wire to the wires in the junction box using wire nuts, (see **Figures 46–47**), then wrap each of the wire nuts and their respective wires with electrical tape to secure them.



**Figure 46.** G0605X1/G0696X incoming power wires connected at junction box.



**Figure 47.** G0606X1/G0697X incoming power wires connected at junction box.

4. Tighten the strain relief on the bottom of the junction box against the conduit—not directly against the wires—then re-install the cover. Leave a little slack in the wires inside the junction box.

## G0606X1/G0697X 440 Power Connection

Hardwire setups require power supply lines to be enclosed inside conduit, which is securely mounted and constructed in adherence to applicable electrical codes.

A hardwire setup for this machine must be equipped with a locking disconnect switch as a means to disconnect the power during adjustments or maintenance, which is a typical requirement for lock-out/tag-out safety programs (commonly required by OSHA).

**Figure 4** on **Page 11** shows a simple diagram of a hardwire setup with a locking disconnect switch between the power source and the machine.

Due to the complexity required for planning, bending, and installing the conduit necessary for a hardwire setup, this type of setup can only be performed by an experienced electrician.

## Phase Converter Precaution

The power from the manufactured leg may damage electrical components if connected to the wrong incoming power terminal on your machine. Refer to the phase converter notice on the wiring diagram on **Page 81** for more detail.



# Test Run

Test run your machine to make sure it runs properly and is ready for regular operation.

The test run consists of verifying the following: 1) The motor powers up and runs correctly, 2) the safety disabling mechanism on the switch works correctly, and 3) the blade turns the correct direction (the machine is not wired out of phase—G0606X/G0697X only).

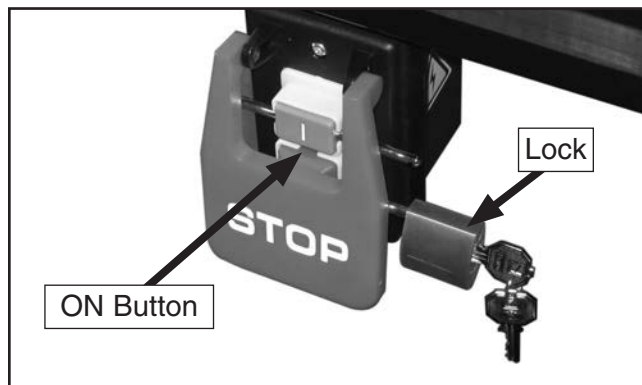
If, during the test run, you cannot easily locate the source of an unusual noise or vibration, stop using the machine immediately, then review **Troubleshooting** on **Page 62**.

If you still cannot remedy a problem, contact our Tech Support at (570) 546-9663 for assistance.

## To test run the machine:

1. Make sure you have read the safety instructions at the beginning of the manual and that the machine is set up properly.
2. Make sure all tools and objects used during setup are cleared away from the machine.
3. Lower the blade all the way down.
4. Check to make sure the machine is connected to the power source. If it is not connected, do so now. Refer to **Power Connection** on **Page 27** for instructions.
5. Remove the switch disabling lock.
6. Verify that the machine is operating correctly by pressing the ON button.
  - When operating correctly, the machine runs smoothly with little or no vibration or rubbing noises.
  - Investigate and correct strange or unusual noises or vibrations before operating the machine further. Always disconnect the machine from power when investigating or correcting potential problems.
7. Turn the machine **OFF**.

8. Insert the switch disabling lock through the green ON button, as shown in **Figure 48**.



**Figure 48.** Switch disabling lock inserted into ON button.

9. Press the green ON button to test the disabling feature on the switch.
  - If the machine does not start, the switch disabling feature is working as designed. Continue to the next step.
  - If the machine starts, immediately stop it. The switch disabling feature is not working correctly. This safety feature must work properly before proceeding with regular operations. Call Tech Support for help.
10. **Model G0606X1/G0697X Only:** Verify that the power is not connected out of phase by starting/stopping the table saw and determining if the motor turns in the correct direction, using the criteria below:
  - If the blade turns clockwise (standing at the left front side of the table saw), it is turning in the correct direction. Go to **Step 11**.
  - If the blade turns counterclockwise and toward the back of the saw (standing at the left front side of the table saw), it is turning in the wrong direction.

Stop the table saw, disconnect the power source, and refer to **Correcting Phase Polarity** on **Page 12** for detailed instructions on reversing the phase polarity.
11. The saw is now ready to operate.



# Final Setup

---

The remaining tasks required for assembling the saw include the following steps: installing the table insert and cutting a slot for the blade, checking fence parallelism, installing the blade guard, and calibrating the blade angle digital readout.

## To complete the remaining assembly steps:

1. DISCONNECT SAW FROM POWER!
2. Install and cut the table insert, as instructed in **Cutting a Zero Clearance Insert** on **Page 39**, then proceed to the next step.
3. Verify that the fence is parallel to the blade/ miter slot and that this setting did not change during shipping (refer to "Clamping Pressure and Parallelism" on **Page 71**). The blade was set parallel with the miter slot at the factory—this affects whether the fence is parallel when mounted to the table.
4. Install the blade guard as instructed in "Installing Blade Guard & Spreader" on **Page 35**.
5. Calibrate the digital readout before operating the saw (refer to **Page 74** for instructions.) Each time power is disconnected the digital readout will also need to be recalibrated.

# Recommended Adjustments

---

For your convenience, the adjustments listed below have been performed at the factory and no further setup is required to operate this machine. However, because of the many variables involved with shipping, we recommend that you verify the following adjustments to ensure that your new saw cuts safely and accurately.

Step-by-step instructions for these adjustments can be found in **SECTION 8: SERVICE**.

## Adjustments that should be verified:

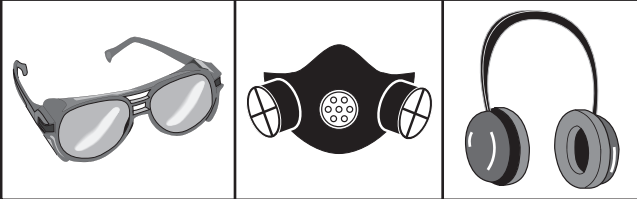
1. Blade Tilt Stop Accuracy (**Page 64**).
2. Miter Slot Parallel to Blade (**Page 66**).



# SECTION 4: OPERATIONS

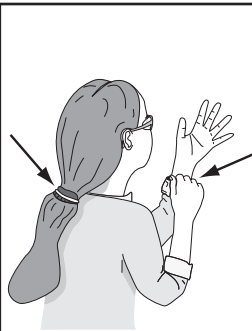
## ! WARNING

Damage to your eyes, lungs, and ears could result from using this machine without proper protective gear. Always wear safety glasses, a respirator, and hearing protection when operating this machine.



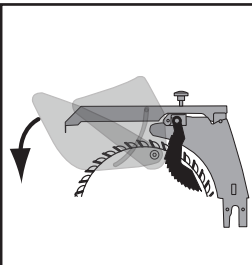
## ! WARNING

Loose hair, clothing, or jewelry could get caught in machinery and cause serious personal injury. Keep these items away from moving parts at all times to reduce this risk.



## ! WARNING

Keep the blade guard in the down position at all times. Failure to do this could result in serious personal injury or death.



## NOTICE

If you have never used this type of machine or equipment before, WE STRONGLY RECOMMEND that you read books, review industry trade magazines, or get formal training before beginning any projects. Regardless of the content in this section, Grizzly Industrial will not be held liable for accidents caused by lack of training.

## Basic Controls

**ON/OFF Switch:** Starts and stops motor.

**Switch Disabling Lock:** This disables the switch to prevent accidental startup and restrict usage.

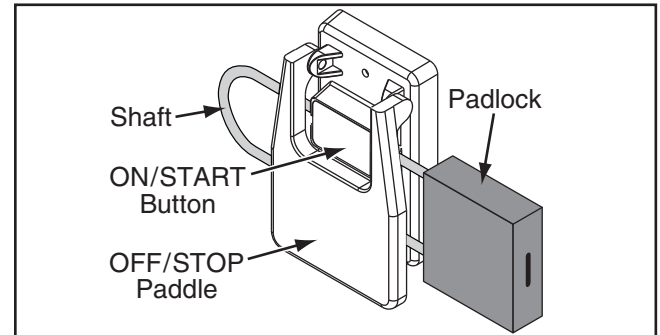


Figure 49. Switch disabled by padlock.

**Blade Height Lock:** Locks the blade height.

**Blade Height Handwheel:** Adjusts blade height.

**Digital Readout:** Displays blade tilt. **Note:** The readout must be recalibrated (see **Page 74**) if the power is disconnected.

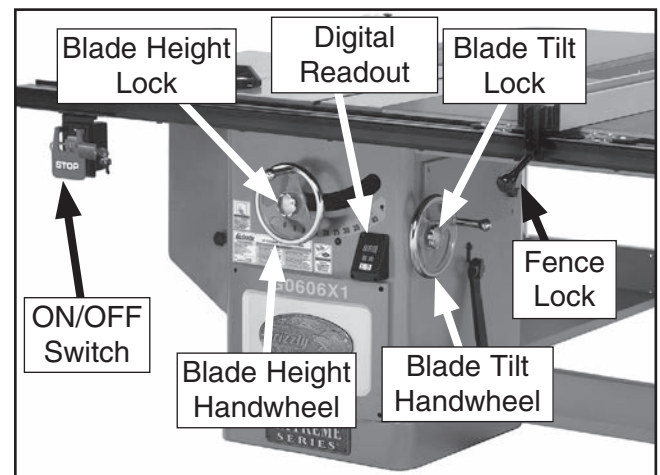


Figure 50. Basic table saw controls.

**Blade Tilt Lock:** Locks blade tilt angle.

**Blade Tilt Handwheel:** Adjusts the blade angle.

**Fence Lock:** Locks and unlocks fence position.



# Operation Overview

The purpose of this overview is to provide the novice machine operator with a basic understanding of how the machine is used during a typical operation, so the controls/components discussed later in this manual are easier to understand.

Due to the generic nature of this overview, it is not intended to be an instructional guide. To learn more about specific operations, read this entire manual, read "how to" books, and seek additional training from experienced machine operators.

**To complete a typical operation, the operator does the following:**

1. Examines the workpiece to make sure it is suitable for cutting.
2. Adjusts the blade tilt, if necessary, to the correct angle of the desired cut.
3. Adjusts the blade height no more than 1/4" higher than the thickness of the workpiece.
4. Adjusts the fence to the desired width of cut then locks it in place.
5. Checks the outfeed side of the machine for proper support and to make sure the workpiece can safely pass all the way through the blade without interference.
6. Puts on safety glasses and a respirator. Locates push sticks/blocks if needed.
7. Starts the saw.
8. Feeds the workpiece all the way through the blade while maintaining firm pressure on the workpiece against the table and fence, and keeping hands and fingers out of the blade path and away from the blade.
9. Stops the machine immediately after the cut is complete.

# Disabling & Locking Switch

The switch can be disabled and locked by inserting a padlock through the ON/START button, as shown. Locking the switch in this manner can prevent unauthorized operation of the machine, which is especially important if the machine is not stored inside an access-restricted building.

**IMPORTANT:** Locking the switch with a padlock only restricts its function. It is not a substitute for disconnecting power from the machine when adjusting or servicing.

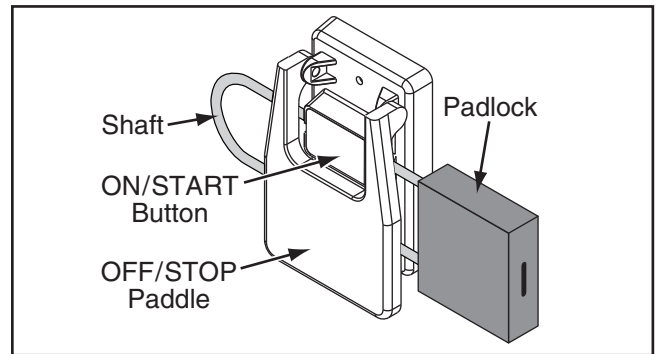


Figure 51. Switch disabled by a padlock.

## WARNING

Children or untrained people can be seriously injured by this machine. This risk increases with unsupervised operation. To help prevent unsupervised operation, disable and lock the switch before leaving machine unattended! Place key in a well-hidden or secure location.

## NOTICE

The padlock shaft diameter is important to the disabling function of the switch. With any padlock used to lock the switch, test the switch after installation to ensure that it is properly disabled.

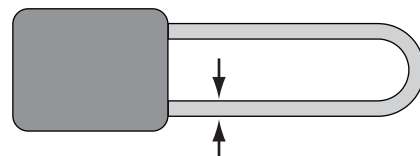


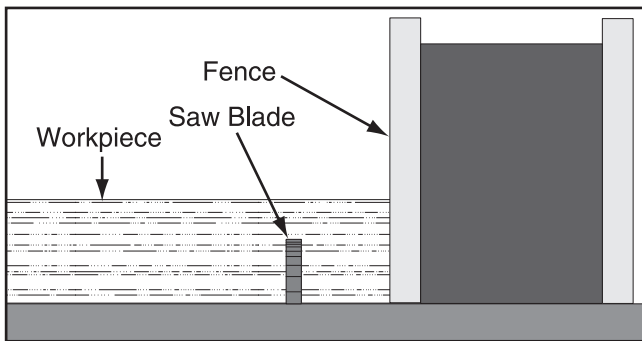
Figure 52. Minimum lock shaft requirements.



# Non-Through & Through Cuts

## Non-Through Cuts

A non-through cut is a sawing operation where the blade does not protrude above the top face of the wood stock, as shown in the **Figure** below.

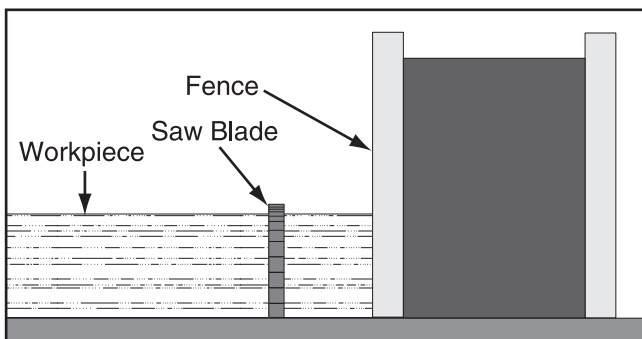


**Figure 53.** Example of a non-through cut.

Examples of non-through cuts include dados and rabbets. Non-through cuts have a higher risk of injury from kickback because the blade guard must be removed. However, the riving knife **MUST** be installed because it still provides some protection. When making non-through cuts with a dado blade, do not attempt to cut the full depth in one pass. Instead, take multiple light passes to reduce the load on the blade. A dado blade smaller than 10" will require removal of the riving knife, because

## Through Cuts

A through cut is a sawing operation in which the workpiece is completely sawn through, as shown in the **Figure** below. Examples of through cuts are rip cuts, cross cuts, miter cuts, and beveled cuts. The blade guard assembly **MUST** be used when performing through cuts.



**Figure 54.** Example of a through cut (blade guard not shown for illustrative clarity).

# Stock Inspection

Some workpieces are not safe to cut or may require modification before they are safe to cut. **Before cutting, inspect all workpieces for the following:**

- **Material Type:** This machine is intended for cutting natural and man-made wood products, laminate covered wood products, and some plastics. Cutting drywall or cementitious backer board creates extremely fine dust and may reduce the life of the motor bearings. This machine is **NOT** designed to cut metal, glass, stone, tile, etc.; cutting these materials with a table saw greatly increases the risk of injury and damage to the saw or blade.
- **Foreign Objects:** Nails, staples, dirt, rocks and other foreign objects are often embedded in wood. While cutting, these objects can become dislodged and hit the operator, cause kickback, or break the blade, which might then fly apart. Always visually inspect your workpiece for these items. If they can't be removed, **DO NOT** cut the workpiece.
- **Large/Loose Knots:** Loose knots can become dislodged during the cutting operation. Large knots can cause kickback and machine damage. Choose workpieces that do not have large/loose knots or plan ahead to avoid cutting through them.
- **Wet or "Green" Stock:** Cutting wood with a moisture content over 20% causes unnecessary wear on the blades, increases the risk of kickback, and yields poor results.
- **Excessive Warping:** Workpieces with excessive cupping, bowing, or twisting are dangerous to cut because they are unstable and may move unpredictably when being cut.
- **Minor Warping:** Slightly cupped workpieces can be safely supported with cupped side facing the table or fence; however, workpieces supported on the bowed side will rock during the cut, which could cause kickback.



# Blade Requirements

The spreader/riving knife included with this machine is 0.09" (2.3mm) thick and is only designed for 12" diameter blades.

When choosing a main blade, make sure the blade size meets the requirements listed below. The thickness of the blade body and teeth can be measured with calipers or any precision measuring device.

## Blade Size Requirements:

- Body Thickness: 0.074"–0.082" (1.9mm–2.1mm)
- Kerf (Tooth) Thickness: 0.114"–0.122" (2.9mm–3.1mm)

# Blade Selection

This section on blade selection is by no means comprehensive. Always follow the saw blade manufacturer's recommendations to ensure safe and efficient operation of your table saw.

## Ripping Blade Features:

- Best for cutting with the grain
- 20-40 teeth
- Flat-top ground tooth profile
- Large gullets for large chip removal

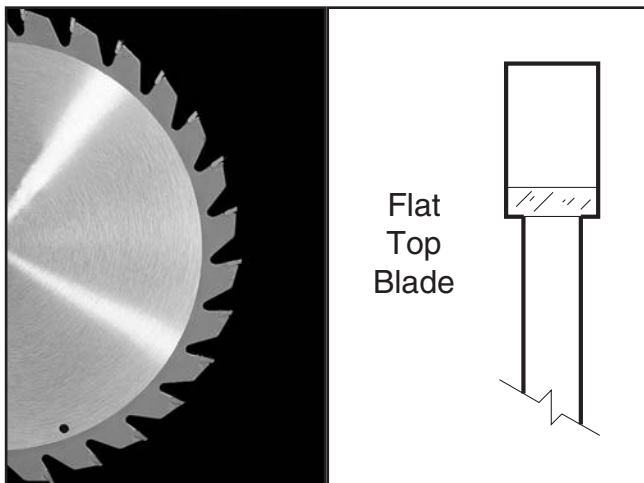


Figure 55. Ripping blade.

## Crosscut Blade Features:

- Best for cutting across the grain
- 60-80 teeth
- Alternate top bevel tooth profile
- Small hook angle and a shallow gullet

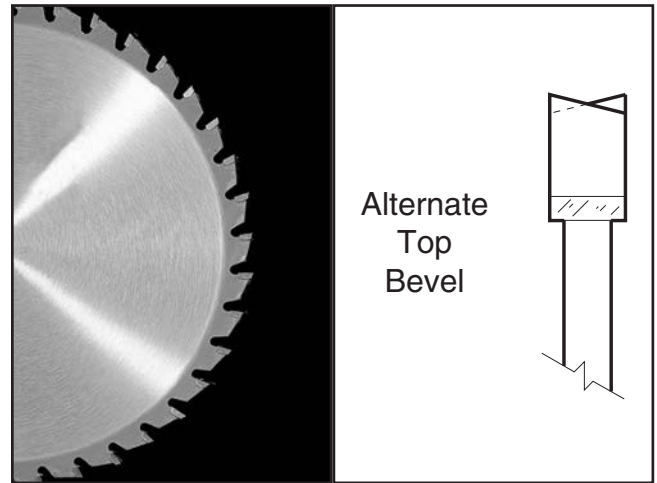


Figure 56. Crosscutting blade.

## Combination Blade Features:

- Designed to cut both with and across grain
- 40-50 teeth
- Alternate top bevel and flat, or alternate top bevel and raker tooth profile
- Teeth are arranged in groups
- Gullets are small and shallow (similar to a cross-cut blade), then large and deep (similar to a ripping blade)

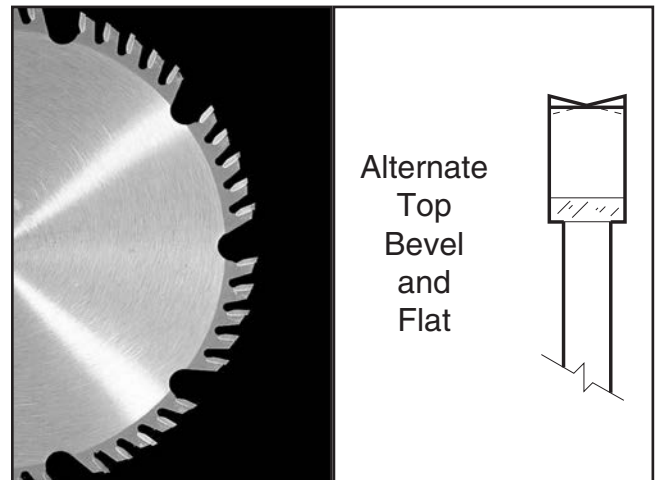


Figure 57. Combination blade.



# Blade Installation

## Laminate Blade Features:

- Best for cutting plywood or veneer
- 40-80 teeth
- Triple chip tooth profile
- Very shallow gullet

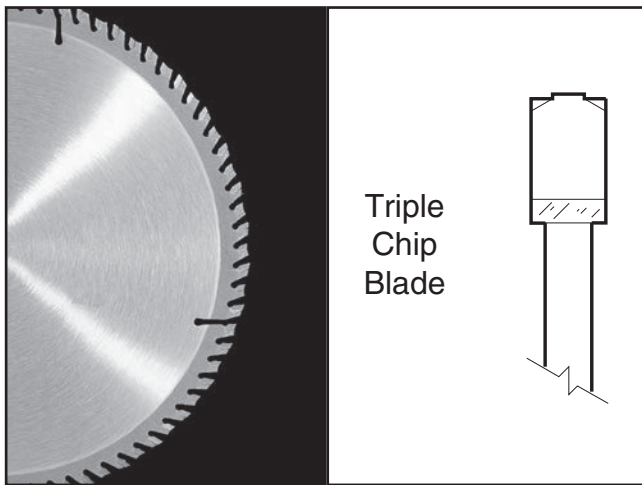


Figure 58. Laminated blade.

**Thin Kerf Blade:** A blade with thinner kerf than a standard blade. Since the spreader/riving knife included with this table saw is sized for standard blades, thin kerf blades cannot be used on this saw unless they meet the **Blade Requirements** specified in this manual; otherwise, they will increase the risk of kickback.

## Dado Blades

**Stacked Dado Blade (see below):** Multiple blades are stacked together to control the cutting width. Stacked dado blades are more expensive than wobble blades, but typically produce higher quality results.

**Wobble Dado Blade:** A single blade mounted at a slight angle on an arbor hub. The blade angle is adjustable on the hub, and the width of the dado cut is controlled by the angle setting of the blade.

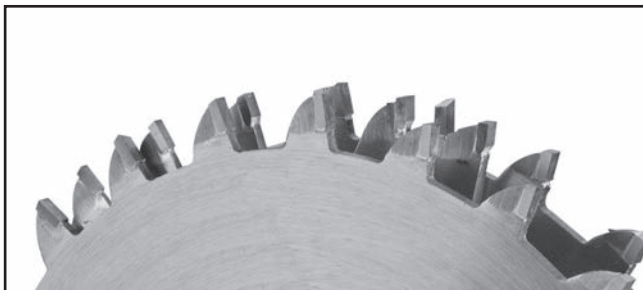


Figure 59. Stacked dado blade.

## To install a new blade:

1. DISCONNECT SAW FROM POWER!
2. Remove the table insert and blade guard/riving knife, depending on what is installed.
3. Use the arbor wrenches to loosen and remove the arbor nut (see **Figure 60**), flange, and blade. **Note:** *The arbor nut has right hand threads; turn it counterclockwise to loosen.*

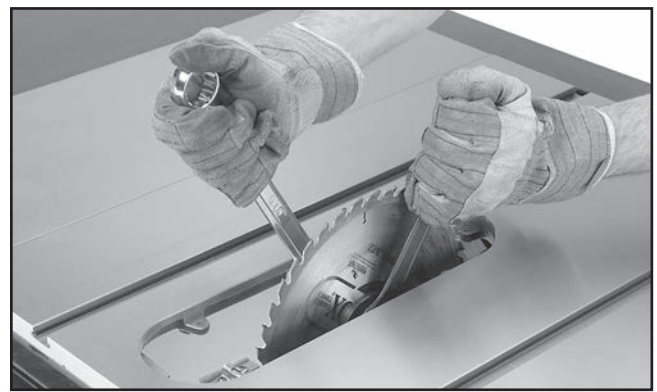


Figure 60. Loosening arbor nut.

4. Slide the blade over the arbor with the teeth facing the front of the saw, as shown in **Figure 61**.

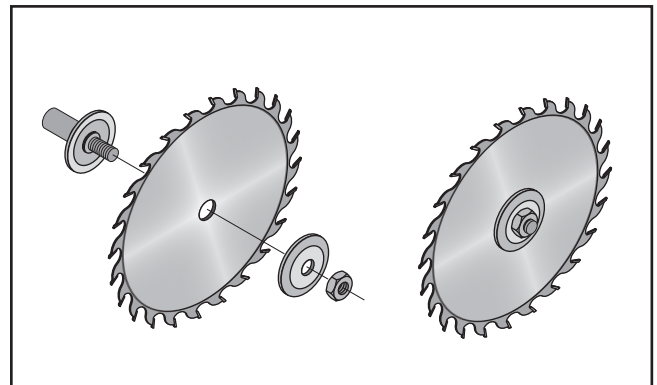


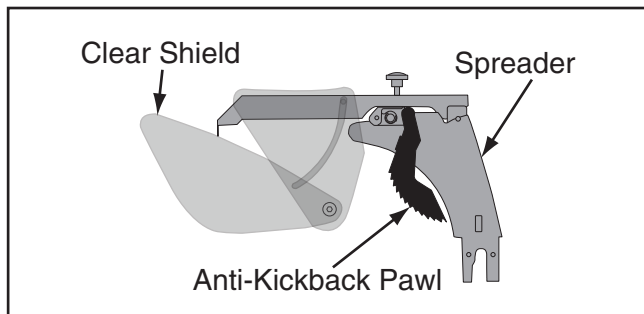
Figure 61. Example of correct blade direction and blade components installation order.

5. Re-install the arbor flange and the arbor nut, then tighten them against the blade with the wrenches included with the saw, as shown in **Figure 60**. DO NOT overtighten.
6. Re-install the blade guard/riving knife and the table insert.



# Blade Guard Assembly

The term "blade guard" refers to the assembly that consists of the clear polycarbonate shield, the spreader, and the anti-kickback pawls on each side of the spreader (**Figure 62**). Each of these components has important safety functions.



**Figure 62.** Blade guard assembly components.

## Guard

The clear polycarbonate guard allows the operator to see the blade cut the workpiece during operation. This guard is designed to lift as the workpiece is pushed into the blade and remain in contact with the workpiece throughout the entire cut.

The guard reduces injury risk by providing a barrier around the blade that prevents accidental contact and contains flying wood chips.

To ensure that the guard does its job effectively, it must always be in the downward position against the table during idle operation, and the hinge mechanism must be maintained in good working condition so the guard can freely pivot up and down to accommodate the height of the workpiece and return to the table surface.

## Spreader

The spreader is a metal plate that prevents the newly cut kerf of the workpiece from pinching the backside of the blade, causing kickback.

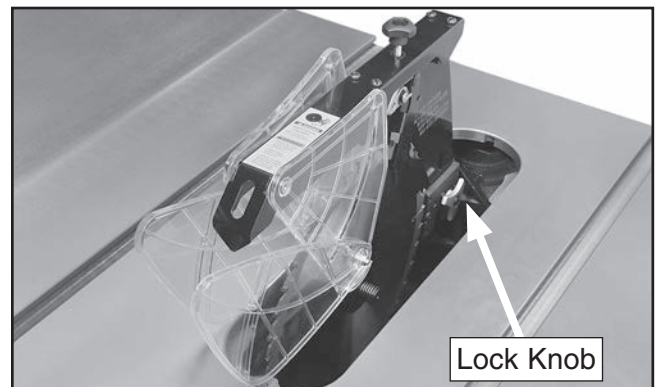
The spreader also acts as a barrier behind the blade to shield hands from being pulled into the blade if kickback occurs.

## **!WARNING**

In order to work properly, the spreader cannot be bent or misaligned with the blade. If the spreader gets accidentally bent, take the time to straighten it or just replace it. Using a bent or misaligned spreader will increase the risk of kickback! Refer to Page 68 to check or adjust alignment if necessary.

## Installing Blade Guard & Spreader

1. DISCONNECT SAW FROM POWER!
2. Remove the table insert.
3. Insert the spreader into the bracket slot and tighten the lock knob shown in **Figure 63** to secure the spreader.



**Figure 63.** Location to secure blade guard.

4. Tug the spreader up to verify it is locked.
5. Lift the blade guard cover just enough to slide the table insert into the table slot over the blade, then secure the insert with the knob on the front of the insert.



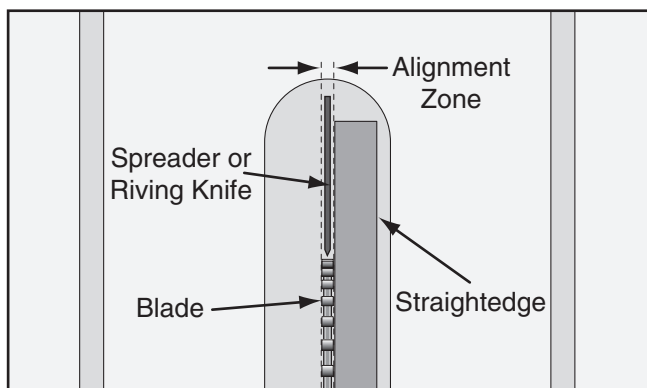
The blade guard, when properly installed, should look like **Figure 64** and should pivot freely so it touches the table surface in the down position. It should also swing up high enough to accommodate the workpiece.



**Figure 64.** Blade guard and insert installed.

6. Check to make sure the blade is 90° to the table. Follow "Setting 90° Stop Bolt" instructions on **Page 64**.
7. Swing one side of the blade guard up and out of the way.
8. While lifting up on the right spreader pawl, place a straightedge against the blade and the spreader.

When properly aligned, the spreader/riving knife will be in the "Alignment Zone," shown in **Figure 65**, and will be parallel with the blade.



**Figure 65.** Spreader/riving knife alignment zone.

—If the spreader/riving knife is not inside the alignment zone and not parallel with the blade, then it needs to be adjusted. Proceed to "Adjusting Alignment" on **Page 68**.

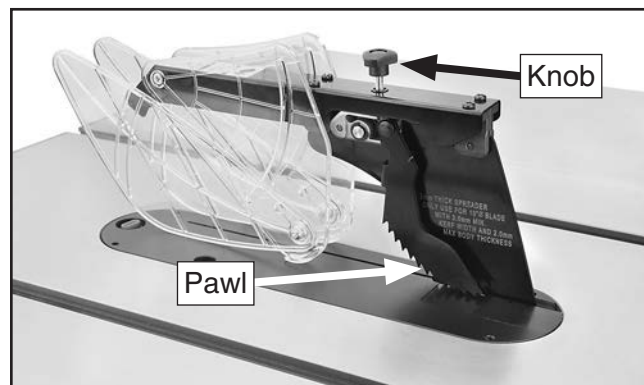
—If the spreader/riving knife is not parallel with the blade, it may be bent. Proceed to "Checking Alignment" on **Page 68** to determine if the spreader/riving knife is bent.

## Anti-Kickback Pawls

Anti-kickback pawls allow the workpiece to travel in only one direction. If the workpiece moves backwards, such as from kickback, the pawls will dig into the workpiece to slow or stop it.

To work properly, the pawls must return to their bottom-most position after pivoting, as shown in **Figure 66**.

**Note:** *The right pawl is designed to tilt slightly away from the blade guard assembly to prevent the pawl from catching in the table insert.*



**Figure 66.** Pawls in return position.

If the pawls fail to return to the bottom position, the pivot spring may have been dislodged or broken and will need to be fixed/replaced.

## Removing Pawls

You might remove the pawls if you are concerned about them scratching a delicate workpiece, or if you believe that they will obstruct a narrow workpiece and cause feeding difficulty or loss of control. Use your best judgment before removing the pawls, as they are provided for your safety.

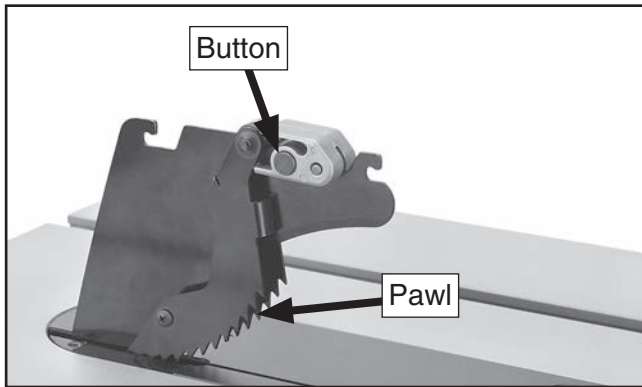


## **!WARNING**

**We do not recommend removing the pawls during normal operations unless absolutely necessary. In most situations, removing the pawls will increase your risk of serious personal injury in the event of kickback.**

### **To remove the pawls:**

1. Loosen the knob on top of the spreader several turns, then remove the blade guard assembly.
2. Press the button (Figure 67) on the block that holds the pawls, then remove the pawls from the spreader.

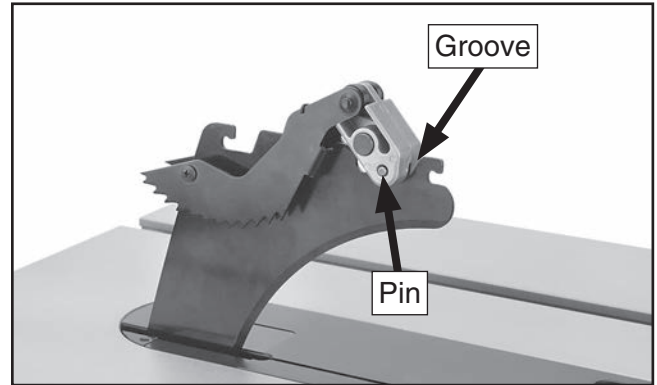


**Figure 67.** Button for removing pawls.

3. Re-install the blade guard onto the spreader, making sure the front and back pins on the blade guard slide all the way into the spreader slots, then tighten the top knob to secure the guard.

### **Re-installing Pawls**

1. Loosen the knob on top of the spreader, then remove the blade guard.
2. Slide the pin in the pawl block into the second groove from the front of the spreader, as shown in Figure 68.



**Figure 68.** Re-installing pawls.

3. Press the button on the pawl block shown in Figure 67, then pivot the pawls down until they lock into place.
4. Re-install the blade guard onto the spreader and secure with the top knob.

### **When to Use the Blade Guard**

The blade guard assembly **MUST** always be installed on the saw for all normal through cuts (those where the blade cuts all the way through the thickness of the workpiece).

### **When Not to Use the Blade Guard**

The blade guard cannot be used for any non-through cuts (those in which the blade does not cut all the way through the thickness of the workpiece).

Sometimes the blade guard or its components can get in the way when cutting very narrow workpieces or other specialized cuts. Because the blade guard is provided to decrease your risk of injury, it should not be used if it gets in the way of making a safe cut. Use good judgment!

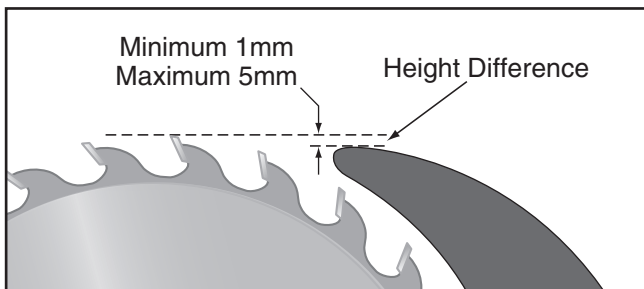
**IMPORTANT:** Whenever the blade guard cannot be used, the riving knife must be installed.



# Riving Knife

The riving knife works in the same manner as the spreader on the blade guard assembly. It is a metal plate that prevents the newly cut workpiece from pinching the backside of the blade and causing kickback.

The key difference between the spreader and the riving knife is that the riving knife mounts below the blade's highest point of rotation, as shown in **Figure 69**.

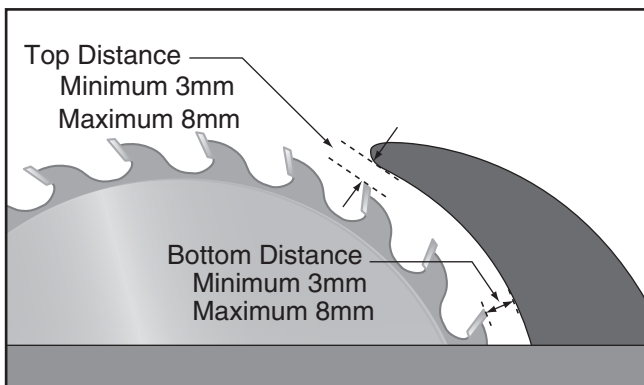


**Figure 69.** Height difference between riving knife and blade.

The height difference between the riving knife and the blade allows the workpiece to pass over the blade during non-through cuts (those in which the blade does not cut all the way through the thickness of the workpiece).

The riving knife acts as a barrier behind the blade to reduce the risk of hands being pulled into the blade if kickback occurs.

The riving knife must be kept within the range shown in **Figure 70**. For that reason, a 12" blade is required for operations that use a riving knife.



**Figure 70.** Allowable top and bottom distances between riving knife and blade.

## !WARNING

To ensure that the riving knife works safely, it **MUST** be aligned with and correctly adjusted to the blade. Refer to **Page 68** to check or adjust the riving knife alignment.

### How to Install the Riving Knife

The riving knife is installed in a similar manner to the blade guard and spreader. Refer to **Blade Guard** on **Page 35** for installation instructions.

### When to Use the Riving Knife

Use the riving knife for all non-through cuts made with a standard table saw blade (i.e., dados or rabbet cuts, and when using a tenoning jig), or when using a 12" diameter dado blade.

Also, use the riving knife for those special operations where the blade guard or its components get in the way of safe operation, such as with very narrow cuts.

### When Not to Use the Riving Knife

Do not use the riving knife with a dado blade that has a diameter smaller than 12" in diameter. Otherwise, the riving knife height will exceed the blade height and the workpiece will hit the riving knife during the cut, forcing the operator into a dangerous situation of trying to turn the saw off with the workpiece stuck halfway through the cut.

In addition, although it is possible to use the riving knife for through cutting operations, the blade guard assembly offers far more injury protection and risk reduction than the riving knife. Therefore, **we strongly recommend** that you use the blade guard assembly instead of the riving knife for through cuts.

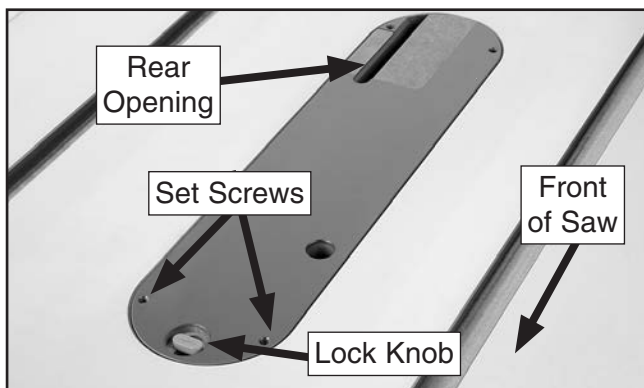


# Cutting a Zero Clearance Insert

A zero clearance insert is provided with the table saw to reduce workpiece tear out and increase user safety. The insert can be customized to fit a specific blade height or blade angle for the applicable cutting operation.

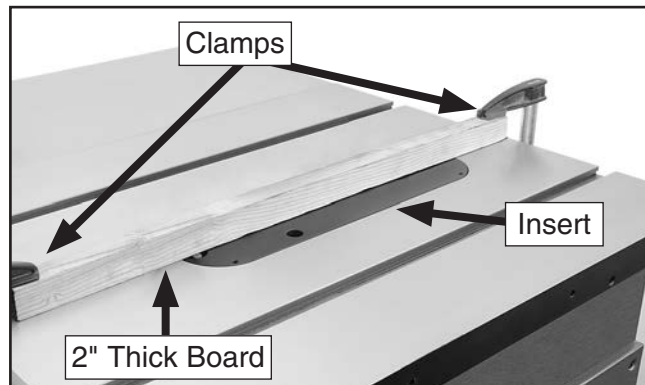
## To install the zero clearance insert:

1. DISCONNECT SAW FROM POWER!
2. Check to make sure the blade is properly installed (refer to the instructions in **Blade Installation** on **Page 34**).
3. Install the table insert, as shown in **Figure 71**.



**Figure 71.** Insert knob in lock position.

4. Adjust the table insert set screws with a 2.5mm hex wrench to make sure the insert is flush with the table (use a straightedge as a guide), then turn the lock knob to secure the insert.
5. Center a board at least 2" thick and equal to the length of the table over the rear opening of the insert, then secure it with clamps at both ends, as shown in **Figure 72**. This will provide extra support for the insert and reduce tear out when cutting.



**Figure 72.** Securing insert with board and clamps.

6. Set the blade angle at 0°.

**Suggestion:** To retain the zero clearance ability of the insert included with this saw, we recommend only raising the blade into the insert at 90° during the following step.

—If you need a zero clearance insert for compound cuts, install an optional phenolic zero clearance table insert, Model T21879 (refer to **Page 58**) for each angled cut, then proceed to **Step 7**.

—If you plan to use a dado blade to cut rabbets or dados, install the optional dado table insert, Model T21878 (see **Page 58**).

—If you do not require your insert to have a zero clearance fit, especially if you need to make a range of compound cuts, you can modify the insert included with this saw. Continue with **Step 7**, then route the underside of the blade-cut slot to the same width as the rear opening (see **Figure 71**).

7. Connect the saw to power. Keep hands off of table top, do not stand directly behind the blade path, and wear eye protection.
8. Turn the saw **ON**, then slowly raise the blade to the maximum height that will be used during normal operations.
9. Turn the saw **OFF**, lower the blade completely, then remove the board and clamps.
10. Install the blade guard (refer to "Installing Blade Guard & Spreader" on **Page 35**).



# Ripping

"Ripping" means cutting with the grain of a natural wood workpiece. In man-made materials such as MDF or plywood, ripping simply means cutting lengthwise.

## **!WARNING**

**Serious injury can be caused by kickback. Kickback is a high-speed expulsion of stock from the table saw toward an operator. The operator or bystanders may be struck by flying stock, or the operator's hands can be pulled into the blade during kickback.**

### To make a rip cut:

1. Review **Preventing Kickback** on **Page 8** and take the necessary precautions to prevent kickback.
2. If using natural wood, joint one long edge of the workpiece on a jointer.
3. **DISCONNECT SAW FROM POWER!**
4. Ensure that the blade guard and spreader is installed.
5. Set the fence to the desired width of cut on the scale.
6. Adjust the blade height so the highest saw tooth protrudes no more than  $\frac{1}{4}$ " above the workpiece.
7. Set up safety devices such as featherboards or other anti-kickback devices.
8. Rotate the blade by hand to make sure it does not come into contact with any of the safety devices.
9. Connect the saw to the power source, turn it **ON**, and allow it to reach full speed.

**Note:** *The jointed edge of the workpiece must slide against the fence during the cutting operation.*

10. Use a push stick to feed the workpiece through the saw blade, as shown in **Figure 73**, until the workpiece is completely beyond the saw blade.

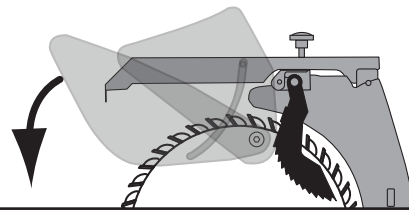


**Figure 73.** Typical ripping operation.

## **!WARNING**

**Turn OFF the saw and allow the blade to come to a complete stop before removing the cut-off piece. Failure to follow this warning could result in serious personal injury.**

## **!WARNING**



**Keep the blade guard installed and in the down position. Failure to do this could result in serious personal injury or death.**

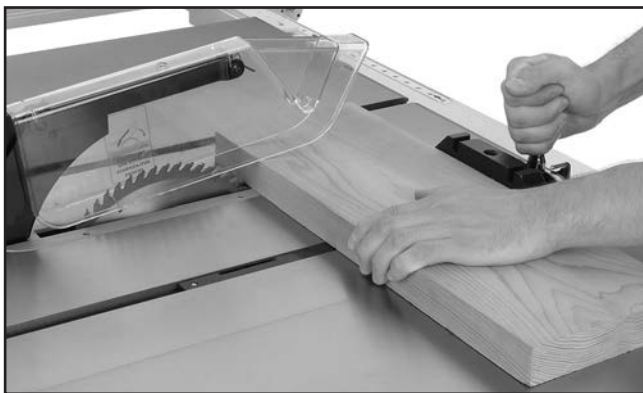


# Crosscutting

"Crosscutting" means cutting across the grain of a natural wood workpiece. In man-made materials, such as MDF or plywood, crosscutting means cutting across the width of the workpiece.

**To make a crosscut using the miter gauge:**

1. DISCONNECT SAW FROM POWER!
2. Ensure that the blade guard/spreader is installed.
3. Move the rip fence aside and position the miter gauge, adjusted to 90°, in a miter slot.
4. Adjust the blade height so the teeth protrude no more than ¼" above the workpiece.
5. Slide the miter gauge near the blade and adjust the workpiece so the blade will cut on the waste side of the line.
6. Plug in the table saw, turn it **ON**, and allow it to reach full speed.
7. Hold the workpiece firmly against the face of the miter gauge (**Figure 74**), and ease it through the blade until the workpiece is completely past the saw blade.



**Figure 74.** Typical crosscutting operation.

## **!WARNING**

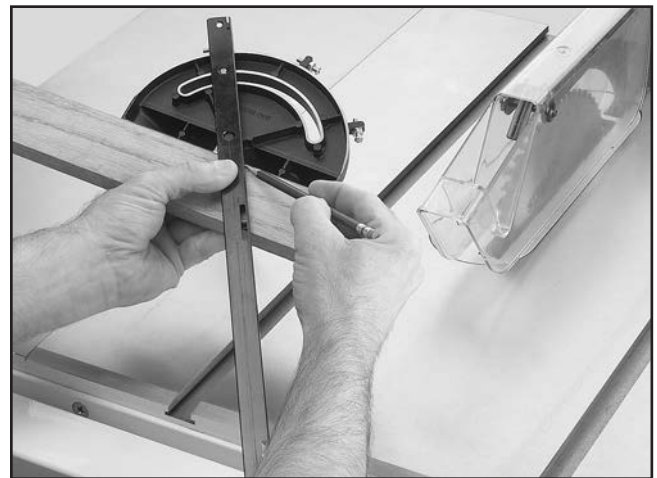
Turn **OFF** the saw and allow the blade to come to a complete stop before removing the cut-off piece. Failure to follow this warning could result in serious personal injury

# Miter Cuts

A miter is an angled crosscut. Miters are usually cut in the same manner as crosscuts, using the miter gauge and a predetermined mark on the workpiece.

**To perform a miter cut:**

1. DISCONNECT SAW FROM POWER!
2. Ensure that the blade guard/spreader is installed.
3. Determine the angle of your cut. If the angle needs to be very precise, use a protractor to set the miter gauge to the blade.
4. Place the face of the miter gauge against the edge of the workpiece and place the bar across the face of the workpiece. Use the bar as a guide to mark your cut, as shown in **Figure 75**.



**Figure 75.** Example of marking miter line.

5. Place the miter gauge back into the slot and hold the workpiece firmly against the miter gauge body. Slide the miter gauge near the blade and adjust the workpiece so the blade will cut on the waste side of the line.
6. Proceed to make the cut in the same manner as described in the **Crosscutting** instructions.



# Blade Tilt/Bevel Cuts

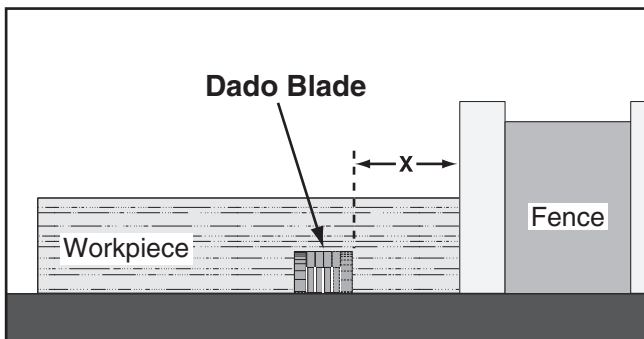
When the blade tilt stop bolts are properly adjusted (as described on **Page 64**), the blade tilt handwheel allows the operator to tilt the blade to the left, between 0° and 45°. This is used most often when cutting bevels, compound miters or chamfers. **Figure 76** shows an example of the blade when tilted to 45°.



**Figure 76.** Blade tilted to 45° for bevel cutting on a typical table saw.

# Dado Cutting

Commonly used in furniture joinery, a dado is a straight channel cut in the face of the workpiece. Dadoes can be cut using either a dedicated dado blade or a standard saw blade. **Figure 77** shows a cutaway view of a dado cut being made with a dado blade.



**Figure 77.** Example of a dado cut with a dado blade.

The included dado table insert or optional zero clearance table insert, Model T21878, must be installed when using a dado blade. The standard insert included with the saw or the Model T21879 must be installed when using a standard saw blade.

# Installing a Dado Blade

1. DISCONNECT SAW FROM POWER!
2. Remove the table insert, the blade guard assembly or riving knife, and the saw blade.
3. Adjust the width of the dado blade system according to the dado blade manufacturer's instructions, then install it on the arbor.
4. Install the dado table insert.

## ⚠ WARNING

Dado blades have a higher risk of kickback than normal blades because their larger size applies stronger forces to the workpiece. This risk increases relative to the depth and width of the cut. To minimize your risk of serious personal injury, ensure that stock is flat and straight, and make multiple light cuts (rather than one deep cut) to achieve the desired cutting depth.

## ⚠ WARNING

DO NOT make through cuts with a dado blade. Dado blades are only intended for non-through cuts. Failure to heed this warning could result in serious injury.

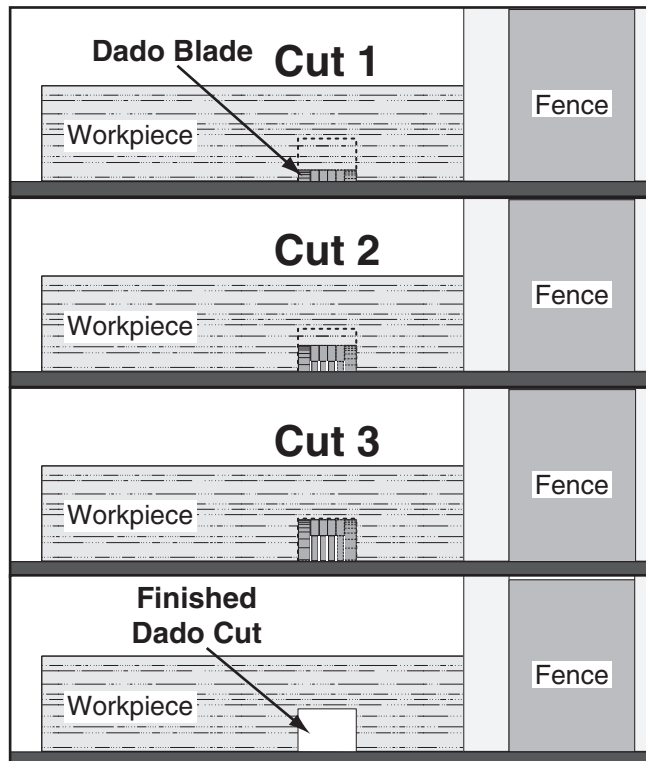
## ⚠ WARNING

Never try to dado a warped board by holding it down against the table. If kickback occurs, your hand will likely be pulled into the blade, resulting in serious personal injury.



## Cutting Dados with a Dado Blade

The **Figure** below demonstrates the sequential process of making multiple, light cuts that get progressively deeper. The actual number of cuts used should be determined by workpiece hardness, total dado depth, and feed rate. In general, if you hear the motor slow down during the cut, you are cutting too deep or feeding too fast.



**Figure 78.** Example of dado being cut with multiple light cuts, instead of one deep cut.

### To cut a dado with a dado blade:

1. Adjust the dado blade to the desired depth of cut.
2. Adjust the distance between the fence and the inside edge of the blade, as shown in **Figure 77**, to dado the length of a workpiece.
  - If dadoing across the workpiece, use the miter gauge and carefully line up the desired cut with the dado blade. **DO NOT** use the fence in combination with the miter gauge.
3. Reconnect the saw to the power source.
4. Turn the saw **ON**. The blade should run smooth, with no vibrations.
5. When the blade has reached full speed, perform a test cut with a scrap piece of wood.
6. If the cut is satisfactory, repeat the cut with the actual workpiece.

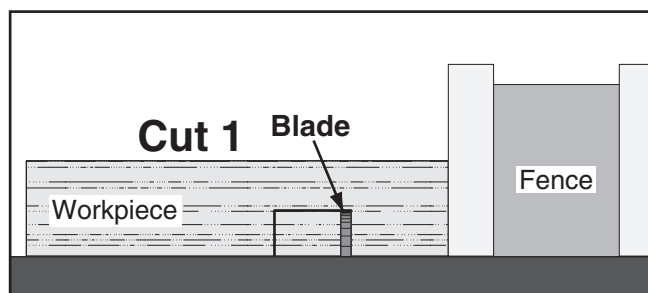


## Cutting Dados with Standard Blade

A ripping blade (described on **Page 33**) is typically the best blade to use for cutting dados when using a standard blade, because it removes sawdust very efficiently.

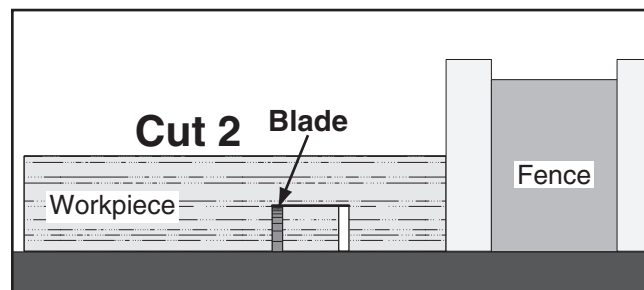
### To use a standard saw blade to cut dados:

1. DISCONNECT SAW FROM POWER!
2. Ensure that the riving knife and standard table insert are installed and properly adjusted. Do not use the standard insert if it has lost the zero clearance feature by modification; if so, you must install the optional Model T21879.
3. Mark the width of the dado cut on the workpiece. Include marks on the edge of the workpiece so the cut path can be aligned when the workpiece is lying on the table.
4. Raise the blade up to the desired depth of cut (depth of dado channel desired).
5. Set up the saw for the type of cut you need to make, depending on if it is a rip cut (**Page 40**) or crosscut (**Page 41**).
6. Align the blade to cut one of the dado sides, as shown in **Figure 79**.



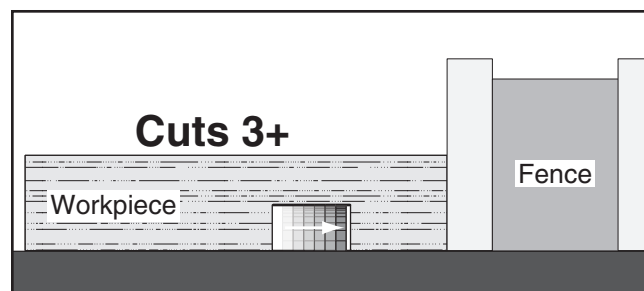
**Figure 79.** First cut for a single-blade dado.

7. Reconnect the saw to the power source and turn the saw **ON**. Allow the blade to reach full speed, then perform the cutting operation.
8. Repeat the cutting operation on the other side of the dado channel, as shown in **Figure 80**.



**Figure 80.** Second cut for a single-blade dado.

9. Make additional cuts (see **Figure 81**) in the center of the dado to clear out the necessary material. The dado is complete when the channel is completely cleared out.



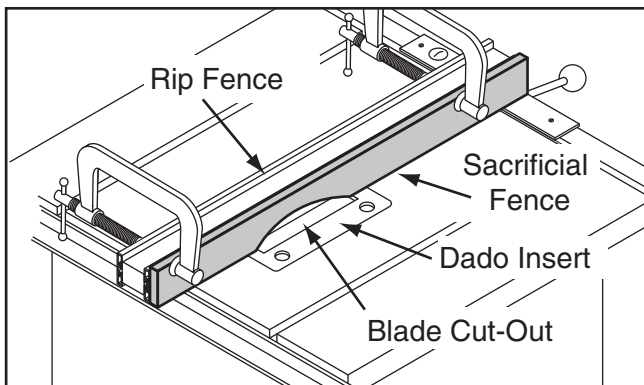
**Figure 81.** Additional single-blade dado cuts.



# Rabbet Cutting

Commonly used in furniture joinery, a rabbet is an L-shaped groove cut in the edge of the workpiece. Rabbets can be cut with either a dado blade or a standard saw blade.

Rabbet cutting on the edge of the workpiece with a dado blade requires a sacrificial fence (**Figure 82**). Make the sacrificial fence the same length as the fence and  $\frac{3}{4}$ " thick. Attach it to the fence with screws or clamps, making sure they are all secure and tight. Raise the blade into the sacrificial fence to the height needed.



**Figure 82.** Sacrificial fence.

When using a dado blade, either the optional dado insert, Model T21878 or the optional zero clearance table insert, Model T21879 (see **Page 58**), must be installed and used during rabbeting operations.

## **!WARNING**

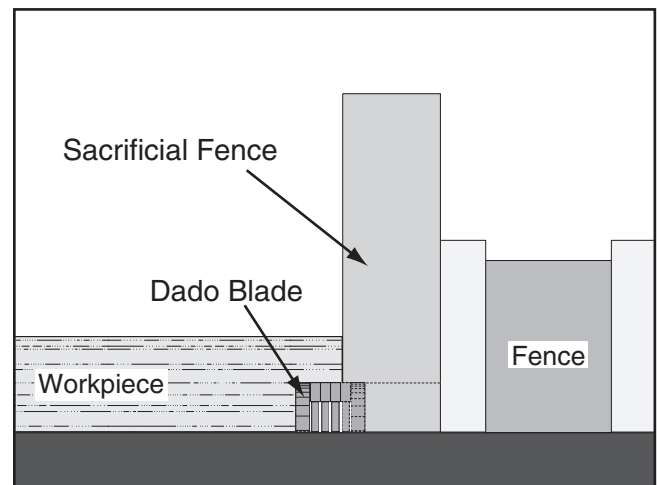
**Dado blades have a higher risk of kickback than normal blades because their larger size applies stronger forces to the workpiece. This risk increases relative to the depth and width of the cut. To minimize your risk of serious personal injury, ensure that stock is flat and straight, and make multiple light cuts (rather than one deep cut) to achieve the desired cutting depth.**

## **!CAUTION**

**Always use push sticks, featherboards, push paddles and other safety accessories whenever possible to increase safety and control during operations which require that the blade guard be removed from the saw. ALWAYS replace the blade guard after dadoing is complete.**

## Cutting Rabbets with a Dado Blade

1. DISCONNECT SAW FROM POWER!
2. Adjust the dado blade to the height needed for the rabbeting operation. When cutting deep rabbets, take more than one pass to reduce the risk of kickback.
3. Adjust the fence and align the workpiece to perform the cutting operation, as shown in **Figure 83**.



**Figure 83.** Rabbet cutting.

4. Reconnect the saw to the power source and turn the saw **ON**. When the blade has reached full speed, perform a test cut with a scrap piece of wood.  
—If the cut is satisfactory, repeat the cut with the final workpiece.

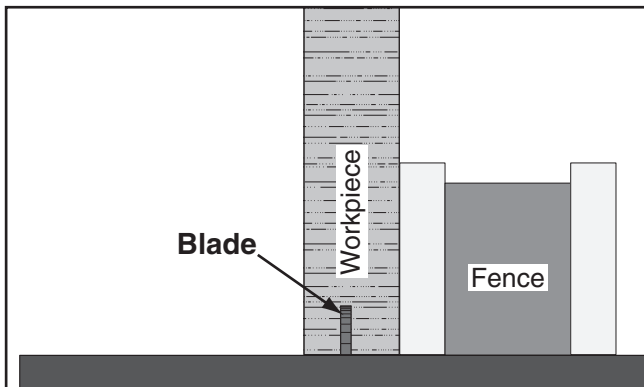


## Cutting Rabbets with a Standard Blade

A ripping blade is typically the best blade to use for cutting rabbets when using a standard blade because it removes sawdust very efficiently. (See **Page 33** for blade details.) Also, a sacrificial fence is not required when cutting rabbets with a standard blade.

### To cut rabbets with the standard blade:

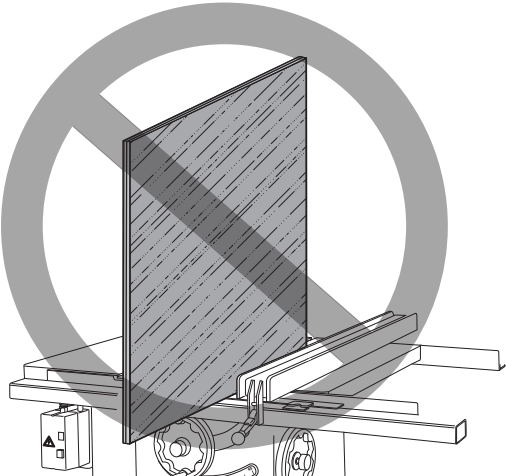
1. DISCONNECT SAW FROM POWER!
2. Ensure that the riving knife and standard table insert are installed.
3. Mark the width of the rabbet cut on the edge of the workpiece, so you can clearly identify the intended cut while it is laying flat on the saw table.
4. Raise the blade up to the desired depth of cut (depth of rabbet channel desired).
5. Stand the workpiece on edge, as shown in **Figure 84**, then adjust the fence so the blade is aligned with the inside of your rabbet channel.



**Figure 84.** Rabbet cutting with a standard blade.

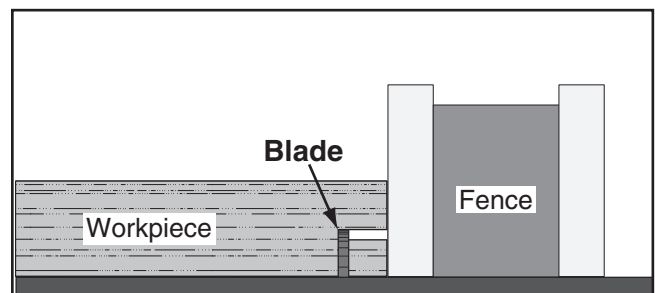
—If the workpiece is very tall, or is unstable when placed against the fence, lay it flat on the table and use a dado blade to perform the rabbet cut.

**! WARNING**



**DO NOT** place a tall board on edge to perform a rabbet cut with a standard blade. Workpieces that are too tall to properly support with the fence can easily shift during operation and cause kickback. Instead, place the stock flat on the saw and perform the rabbet cut with a dado blade, as instructed on **Page 45**.

6. Reconnect the saw to the power source, then perform the cut.
7. Lay the workpiece flat on the table, as shown in **Figure 85**, adjust the saw blade height to intersect with the first cut, then perform the second cut to complete the rabbet.



**Figure 85.** Second cut to create a rabbet.



# Resawing

## **!WARNING**

Resawing operations require proper procedures to avoid serious injury. Extra care must be taken to prevent kickback when resawing. Any tilting or movement of the workpiece away from the fence will cause kickback. Be certain that stock is flat and straight. Failure to follow these warnings could result in serious personal injury.

Resawing is the process of cutting a thick piece of stock into one or more thinner pieces. Although resawing can be done with a table saw, we strongly recommend that you use a bandsaw instead.

A bandsaw is the ideal machine for resawing, and resawing with one is fairly easy and safe. A table saw is not intended for resawing, and resawing with one is difficult and dangerous due to the increased risk of kickback from binding and deep cuts, and the increased risk of injury from having to remove the guard.

If you insist on resawing with a table saw, DO NOT do so without using a resaw barrier and wearing a full face shield. The following instructions describe how to build a resaw barrier and add an auxiliary fence to your standard fence, to reduce the risk injury from resawing on a table saw.

**Note:** This table saw can only resaw wood that is less than 8" tall.

## Making Resaw Barrier

The resaw barrier acts in tandem with the rip fence when resawing to provide tall support for the workpiece to minimize the probability of it binding against the blade and causing kickback.

Tools Needed:	Qty
Table Saw .....	1
Jointer and Planer .....	Recommended
Clamps .....	2 Minimum
Drill and Drill Bits .....	1

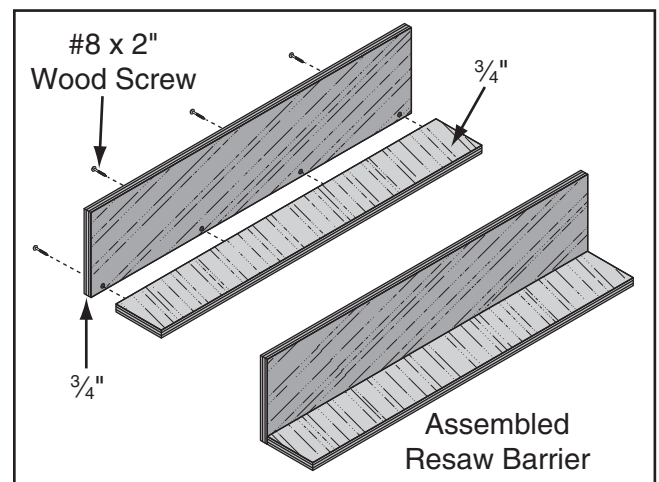
### Components Needed for Resaw Barrier:

Wood* $\frac{3}{4}$ " x $7\frac{1}{2}$ " x Length of Fence .....	1
Wood* $\frac{3}{4}$ " x 3" x Length of Fence .....	1
Wood Screws #10 x 2" .....	4
Wood Glue .....	As Needed

\* Only use furniture grade plywood, kiln dried hardwood, or HDPE plastic to prevent warping.

### To build the resaw barrier:

1. Cut your wood pieces to the size specified above. If you are using hardwood, cut the pieces oversize, then joint and plane them to the correct size to make sure they are square and flat.
2. Pre-drill and countersink four holes approximately  $\frac{3}{8}$ " from the bottom of the  $7\frac{1}{2}$ " tall wood piece.
3. Glue the end of the 3" board, then clamp the boards at a 90° angle with the larger board in the vertical position, as shown in **Figure 86**, then fasten together with the wood screws.



**Figure 86.** Resaw barrier.



## Auxiliary Fence

The auxiliary fence is necessary if you are resawing a workpiece that is taller than it is wide. It should be no less than 1/2" shorter than the board to be resawn.

### Components Needed for the Auxiliary Fence:

Wood* 3/4" x (Height) x Length of Fence .....	1
Flat Head Screws M8-1.25 x 25 (Not included) .	4
Hex Nuts M8-1.25 (Included) .....	4
Flat Washers 8mm (Included) .....	4

\* Only use furniture-grade plywood, kiln dried hardwood, or HDPE plastic to prevent warping.

### Tools Needed for the Auxiliary Fence:

Table Saw .....	1
Jointer and Planer .....	Recommended
Clamps .....	2 Minimum
Drill and Drill Bits .....	1

### To build the auxiliary fence:

1. Cut the auxiliary fence board to size. If you are using hardwood, cut the board oversize, then joint and plane the board to the correct size to make sure the board is square and flat.
2. Pull an end cap off of the standard fence, then remove four hex nuts, flat washers, hex bolts and one side of the fence facing from the fence body.
3. Mark the location of the four fence holes on the top of the fence body.
4. Place the auxiliary fence next to the open side of the fence and transfer the marks from the fence body to the auxiliary fence.
5. Pre-drill and countersink four holes 1 1/4" from the bottom of the board.
6. Thread the flat head screws through the auxiliary fence and into the hex nuts and flat washers inside the standard fence body, and tighten securely, as shown in **Figure 87**.

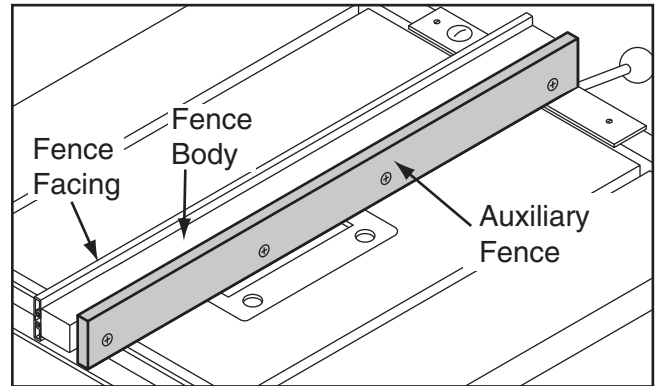


Figure 87. Auxiliary fence.

## Resawing Operations

The table saw motor is pushed to its limits when resawing. If the motor starts to bog down, slow your feed rate. Motor overloading and blade wear can be reduced by using a ripping blade, which are designed to clear the sawdust quickly.

### Components Needed for Resawing:

Zero Clearance Insert.....	1
Ripping Blade 12".....	1
Clamps .....	2
Shop Made Auxiliary Fence .....	1
Shop Made Resaw Barrier .....	1

## ⚠️ WARNING

You may experience kickback during this procedure. Stand to the side of the blade and wear a full face shield to prevent injury when resawing.

### To perform resawing operations:

1. DISCONNECT SAW FROM POWER!
2. Remove the standard table insert and the blade guard assembly.
3. Install a ripping blade, install the riving knife, lower the blade below the table, then re-install the standard insert.

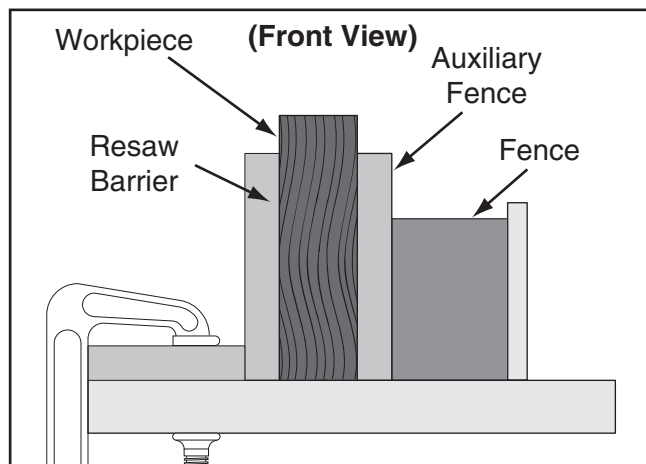
Do not use the standard insert if it has lost the zero clearance feature by modification; if so you must install the optional Model T21879.



- Attach the auxiliary fence to the standard fence and set it to the desired width.

**Note:** When figuring out the correct width, don't forget to account for blade kerf and the inaccuracy of the fence scale while the auxiliary fence is installed.

- Place the workpiece against the auxiliary fence and slide the resaw barrier against the workpiece, as shown in **Figure 88**. Now clamp the resaw barrier to the table at both ends.



**Figure 88.** Ideal resaw workpiece setup.

- Lower the blade completely below the table and slide the workpiece over the blade to make sure it moves smoothly and fits between the resaw barrier and fence.
- Raise the blade approximately an inch, or close to half the height of the workpiece (**Figure 89**), whichever is less.

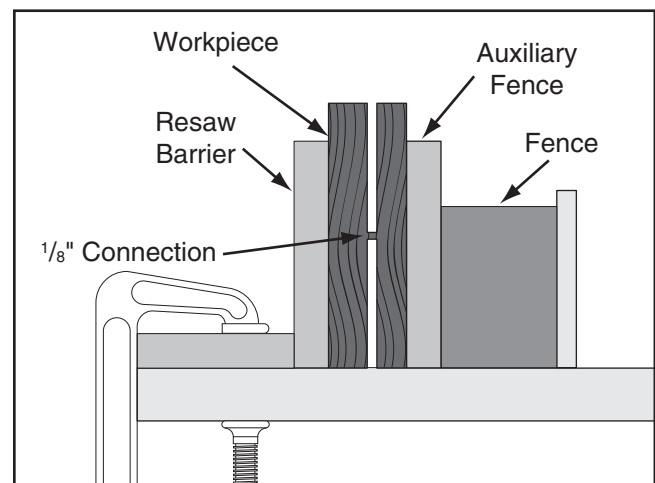
## **! WARNING**

The danger of kickback increases relative to the depth of a cut. Reduce the risk of kickback by making multiple passes to achieve the desired depth of cut. Failure to follow these warnings could result in serious personal injury.

## **! CAUTION**

Always use push sticks or push paddles to increase safety and control during operations which require that the blade guard and spreader must be removed from the saw. **ALWAYS** replace the blade guard after resawing is complete.

- Plug in the table saw, turn it **ON**, and use a push stick or push block to feed the workpiece through the blade, using a slow and steady feed rate.
- Flip the workpiece end for end, keeping the same side against the fence, and run the workpiece through the blade.
- Repeat **Steps 7–9** until the blade is close to half of the height of the board to be resawn. The ideal completed resaw cut will leave an  $\frac{1}{8}$ " connection when the resawing is complete as shown in **Figure 89**. Leaving an  $\frac{1}{8}$ " connection will reduce the risk of kickback.



**Figure 89.** Ideal completed resaw cut.

- Turn **OFF** the table saw, then separate the parts of the workpiece and hand plane the remaining ridge to remove it.
- When finished resawing, remove the resaw barrier and auxiliary fence, re-install the standard fence face, blade guard/spreader or riving knife, and standard table insert.



# SECTION 5: SHOP MADE SAFETY ACCESSORIES

## Featherboards

Easily made from scrap stock, featherboards provide an added degree of protection against kickback, especially when used together with push sticks. They also maintain pressure on the workpiece to keep it against the fence or table while cutting, which makes the operation easier and safer because the cut can be completed without the operator's hands getting near the blade. The angled ends and flexibility of the fingers allow the workpiece to move in only one direction.

### Making a Featherboard

This sub-section covers the two basic types of featherboards: 1) Those secured by clamps to the table or fence, or 2) those secured by a wood runner that mounts in the table saw miter slot.

#### Material Needed for Featherboard Mounted with Clamps

Hardwood  $\frac{3}{4}$ " x 3"-6" x 10" x 28" ..... 1

#### Material Needed for Featherboard Mounted in Miter Slot

Hardwood  $\frac{3}{4}$ " x 3"-6" x 10"-28" ..... 1

Hardwood  $\frac{3}{8}$ " x (Miter Slot Width) x 5"L ..... 1

Wing Nut  $\frac{1}{4}$ "-20 ..... 1

Flat Head Screw  $\frac{1}{4}$ "-20 x 2" ..... 1

Flat Washer  $\frac{1}{4}$ "-20 ..... 1

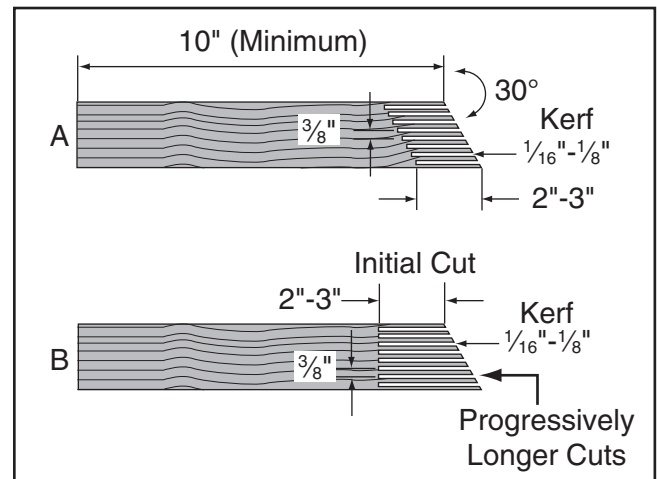
#### To make a featherboard:

1. Cut a hardwood board approximately  $\frac{3}{4}$ " thick to size. The length and width of the board can vary according to your design. Most featherboards are 10"-28" long and 3"-6" wide. Make sure the wood grain runs parallel with the length of the featherboard, so the fingers you will create in **Step 3** will bend without breaking.
2. Cut a 30° angle at one end of the board.

### CAUTION

We recommend using a bandsaw for making fingers in the next step because it tends to be safer. A table saw can be used, but it will over-cut the underside of the ends, produce a thicker kerf, and require you to stop the blade half-way through the cut, which can be dangerous.

3. Make a series of end cuts with the grain  $\frac{3}{8}$ "- $\frac{1}{4}$ " apart and 2"-3" long, as shown in **Figure 90 (A)**. Alternatively, start cuts at 2"-3" deep, then make them progressively deeper, as shown in **Figure 90 (B)**.



**Figure 90.** Patterns for featherboards (top view shown).

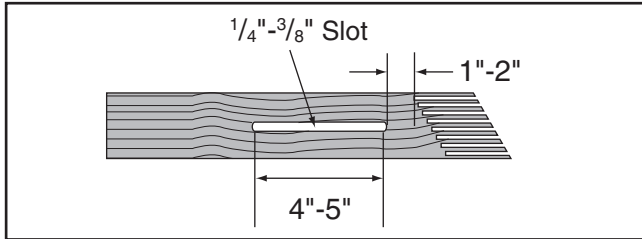
**IMPORTANT:** Cuts made across the grain will result in weak fingers that easily break when flexed. When made correctly, the fingers should withstand flexing from moderate pressure. To test the finger flexibility, push firmly on the ends with your thumb. If the fingers do not flex, they are likely too thick (the cuts are too far apart).

### NOTICE

Only Steps 1-3 are required to make a clamp-mounted featherboard. Refer to Page 52 for instructions on clamping.



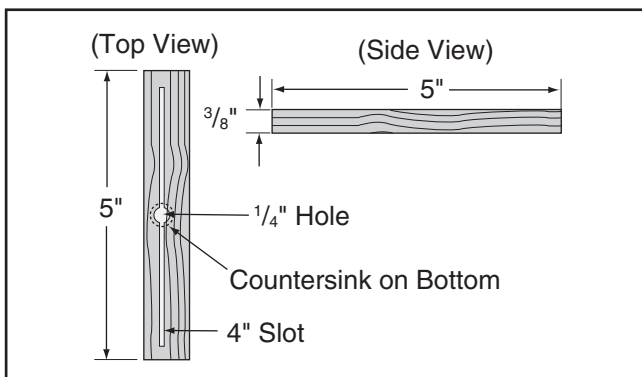
4. Rout a  $\frac{1}{4}$ "- $\frac{3}{8}$ " wide slot 4"-5" long in the workpiece and 1"-2" from the short end of the featherboard (see **Figure 91**).



**Figure 91.** Slot routed in featherboard.

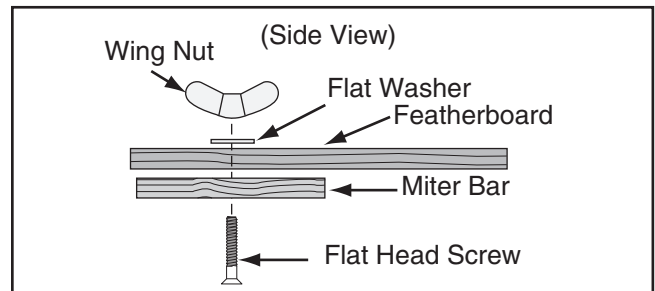
5. Cut a miter bar that will fit in the table miter slot approximately 5" long, as shown in **Figure 92**.

**Tip:** Consider making the miter bar longer for larger featherboards—approximately half the length of the total featherboard—to support the force applied to the featherboard during use.



**Figure 92.** Miter bar pattern.

6. Drill a  $\frac{1}{4}$ " hole in the center of the bar, then countersink the bottom to fit a  $\frac{1}{4}$ "-20 flat head screw.
7. Mark a 4" line through the center of the countersunk hole, then use a jig saw with a narrow blade to cut it out.
8. Assemble the miter bar and featherboard with a  $\frac{1}{4}$ "-20 x flat head screw, flat washer, and a wing nut or a star knob (see **Figure 93**). Congratulations! Your featherboard is complete.



**Figure 93.** Assembling miter slot featherboard components.

**Note:** The routed slot, countersink hole, and the flat head screw are essential for the miter bar to clamp into the miter slot. When the wing nut is tightened, it will draw the flat head screw upward into the countersunk hole. This will spread the sides of the miter bar and force them into the walls of the miter slot, locking the featherboard in place.

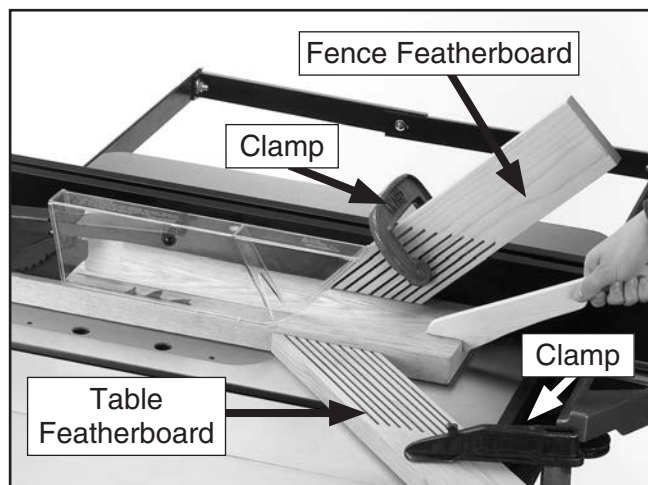
**Tip:** The length of the flat head screw depends on the thickness of the featherboard—though  $1\frac{1}{2}$ " to 2" lengths usually work.

Now, proceed to **Mounting Featherboard in Miter Slot** on **Page 52**.



## Mounting Featherboards w/Clamps

1. Lower the saw blade, then adjust the fence to the desired width and secure it.
2. Place the workpiece against the fence, making sure it is 1" in front of the blade.
3. Place a featherboard on the table away from the blade so all fingers point forward and contact the workpiece (see **Figure 94**).

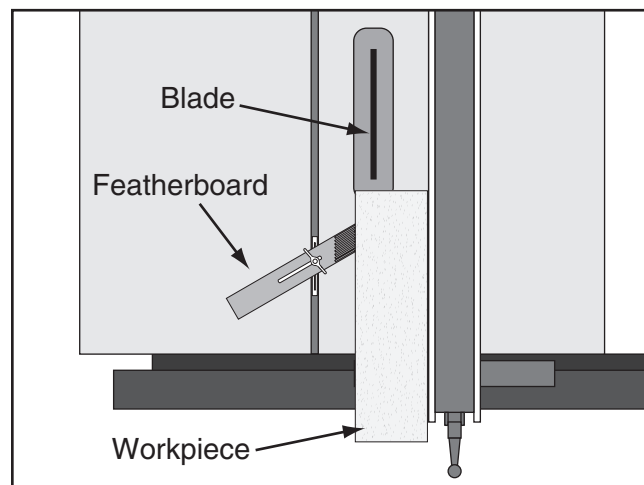


**Figure 94.** Example of featherboards secured with clamps.

4. Secure the featherboard to the table with a clamp.
5. Check the featherboard by pushing it with your thumb to ensure it is secure.  
—If the featherboard moves, tighten the clamp more.
6. Mount a second featherboard to the fence with another clamp (see **Figure 94**), then repeat **Step 5** to ensure it is secure.

## Mounting Featherboard in Miter Slot

1. Lower the saw blade, then adjust the fence to the desired width and secure it.
2. Place the workpiece evenly against the fence, making sure it is 1" in front of the blade.
3. Slide the featherboard miter bar into the miter slot, making sure the fingers point toward the blade, as shown in **Figure 95**.



**Figure 95.** Featherboard installed in miter slot and supporting workpiece for ripping cut.

4. Position the fingered edge of the featherboard against the edge of the workpiece, so that all of the fingers contact the workpiece. Slide the featherboard toward the blade until the first finger is nearly even with the end of the workpiece, which should be 1" away from the blade.
5. Double check the workpiece and the featherboard to ensure they are properly positioned as described in **Step 4**. Then secure the featherboard to the table. Check the featherboard by hand to make sure it is tight.

**Note:** *The featherboard should be placed firmly enough against the workpiece to keep it against the fence but not so tight that it is difficult to feed the workpiece.*



# Push Sticks

When used correctly, push sticks reduce the risk of injury by keeping hands away from the blade while cutting. In the event of an accident, a push stick can also absorb damage that would have otherwise happened to hands or fingers.

## Using a Push Stick

Use push sticks whenever your hands will get within 12" of the blade. To maintain control when cutting large workpieces, start the cut by feeding with your hands then use push sticks to finish the cut, so your hands are not on the end of the workpiece as it passes through the blade.

**Feeding:** Place the notched end of the push stick against the end of the workpiece (see inset **Figure** below), and move the workpiece into the blade with steady downward and forward pressure.

**Supporting:** A second push stick can be used to keep the workpiece firmly against the fence while cutting. When using a push stick in this manner, only apply pressure before the blade; otherwise, pushing the workpiece against or behind the blade will increase the risk of kickback (see "Push Stick Prohibition Zone" in the **Figure** below).

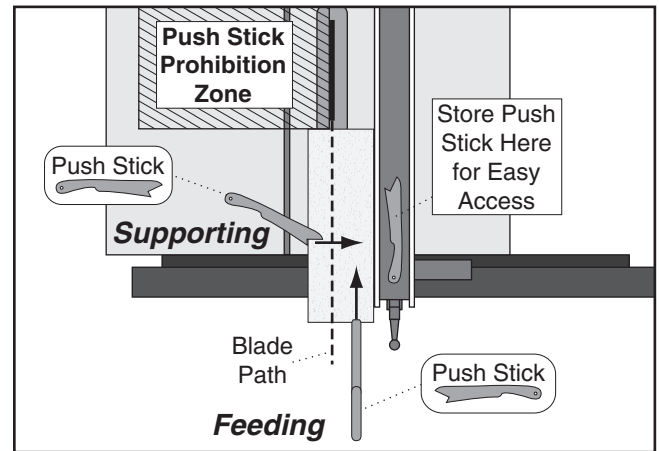


Figure 96. Using push sticks to rip narrow stock.

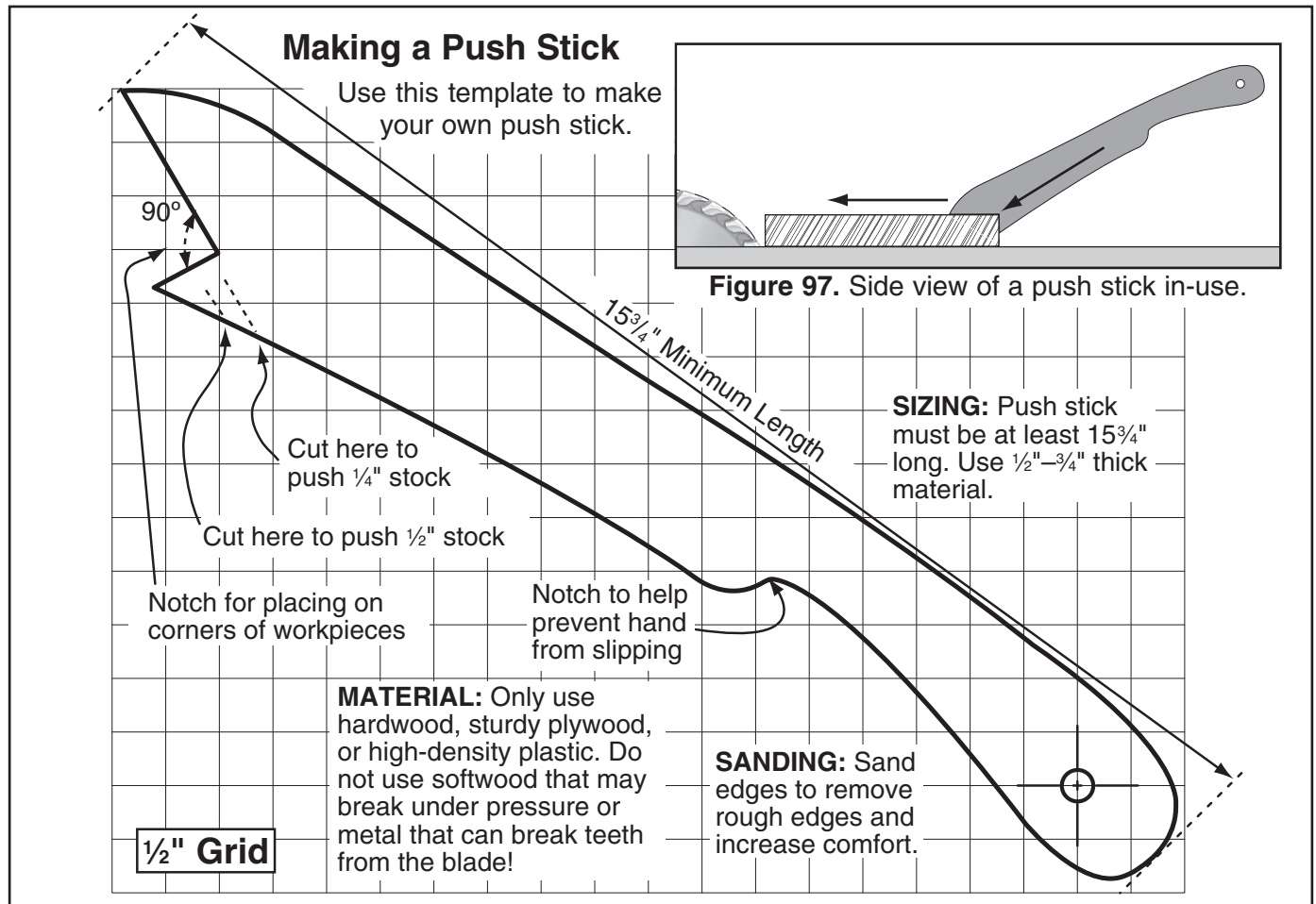


Figure 98. Template for a basic shop-made push stick (not shown at actual size).



# Push Blocks

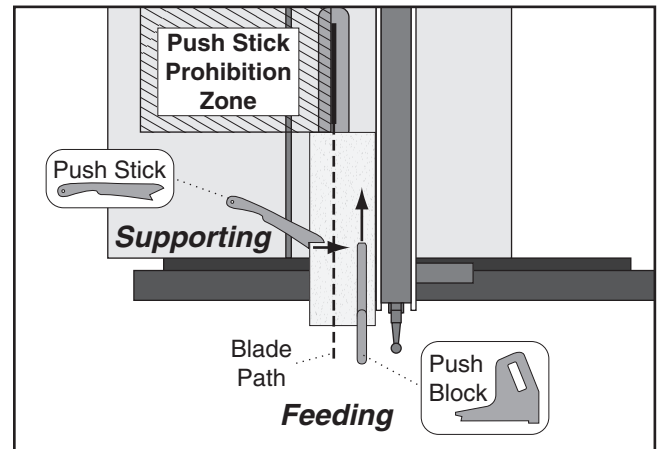
When used correctly, a push block reduces the risk of injury by keeping hands away from the blade while cutting. In the event of an accident, a push block often takes the damage that would have otherwise happened to hands or fingers.

## Using a Push Block

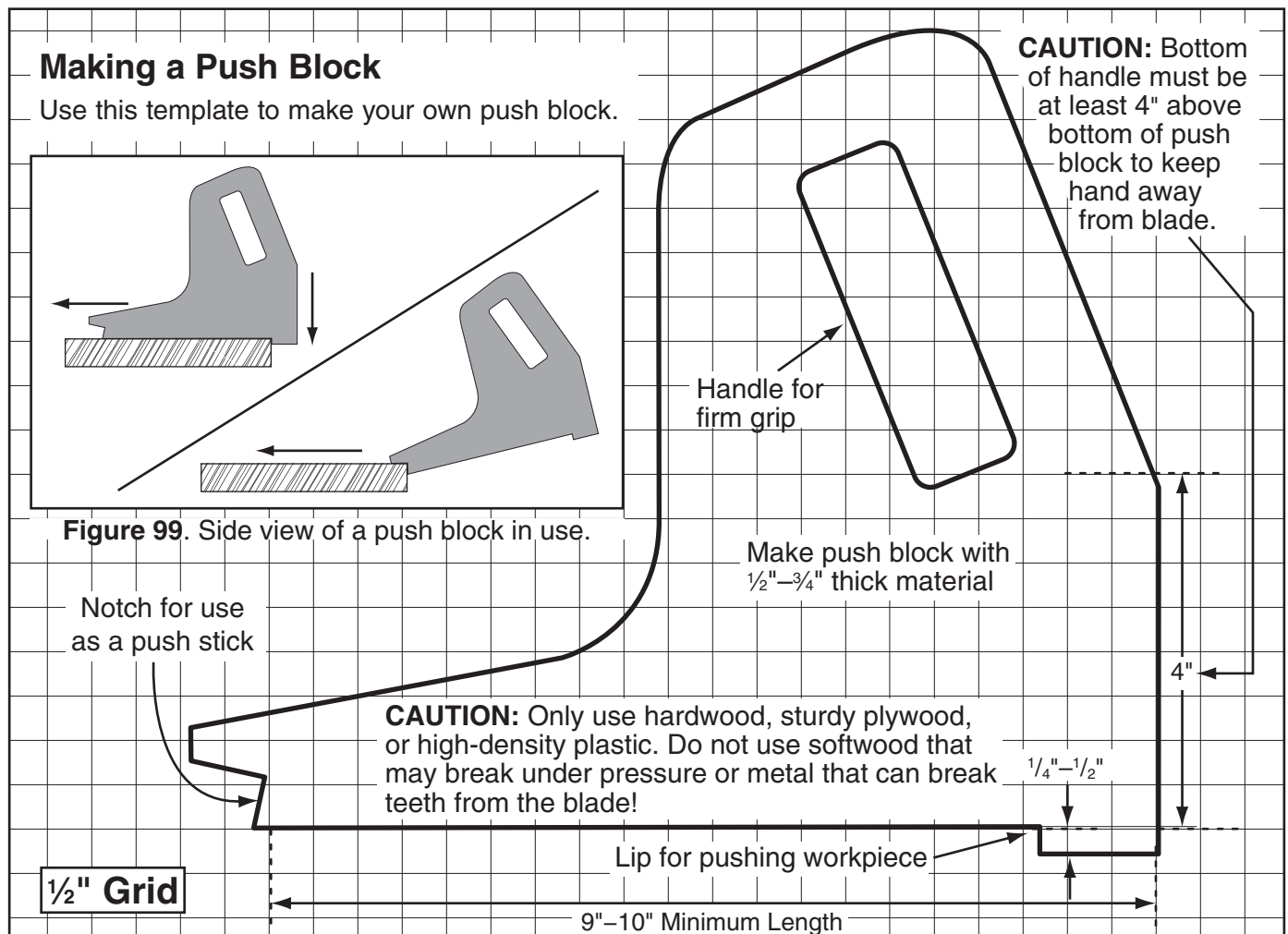
A push block can be used in place of or in addition to a push stick for feeding workpieces into the blade. Due to their design, push blocks allow the operator to apply firm downward pressure on the workpiece that could not otherwise be achieved with a push stick.

The push block design on this page can be used in two different ways (see inset **Figure** below). Typically, the bottom of the push block is used until the end of the workpiece reaches the blade.

The notched end of the push block is then used to push the workpiece the rest of the way through the cut, keeping the operator's hands at a safe distance from the blade. A push stick is often used at the same time in the other hand to support the workpiece during the cut (see "Using a Push Stick" on previous page).



**Figure 100.** Using a push block and push stick to make a rip cut.



**Figure 101.** Template for a shop-made push block (shown at 50% of full size).



# Narrow-Rip Auxiliary Fence & Push Block

There are designs for hundreds of specialty jigs that can be found in books, trade magazines, and on the internet. These types of jigs can greatly improve the safety and consistency of cuts. They are particularly useful during production runs when dozens or hundreds of the same type of cut need to be made.

The narrow-rip auxiliary fence and push block system shown in this section is an example of a specialty jig that can be made to increase the safety of very narrow rip cuts.

## Material Needed for Narrow Rip Auxiliary Fence & Push Block

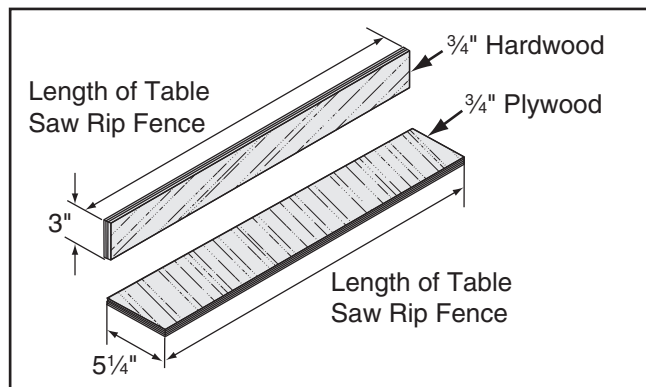
Hardwood  $\frac{3}{4}$ " x 3" x Length of Fence ..... 1  
 Plywood  $\frac{3}{4}$ " x  $5\frac{1}{4}$ " x Length of Fence ..... 1  
 Wood Screws #8 x  $1\frac{1}{2}$ " ..... 8

## Material Needed for Push Block

Hardwood or Plywood  $\frac{3}{4}$ " x 15" x  $5\frac{5}{8}$ " ..... 1  
 Hardwood or Plywood  $\frac{3}{4}$ " x 10" x 5"–9" ..... 1  
 Cyanoacrylate Wood Glue .....Varies  
 Wood Screws #8 x  $1\frac{1}{2}$ " ..... As Needed

## Making a Narrow-Rip Push Block for an Auxiliary Fence

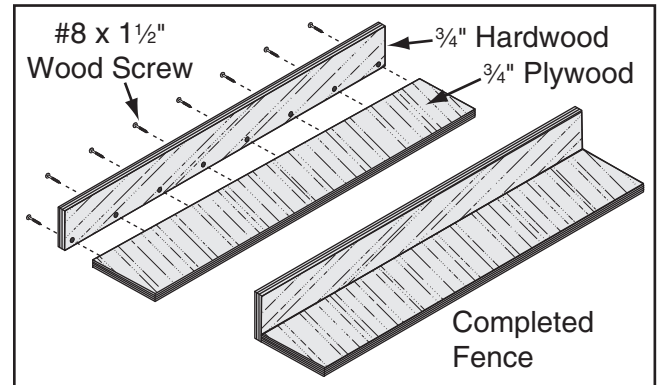
1. Cut a piece of  $\frac{3}{4}$ " thick plywood  $5\frac{1}{4}$ " wide and as long as your table saw fence; cut a piece of  $\frac{3}{4}$ " thick hardwood 3" wide and as long as your table saw fence, as shown in **Figure 102**.



**Figure 102.** Auxiliary fence dimensions.

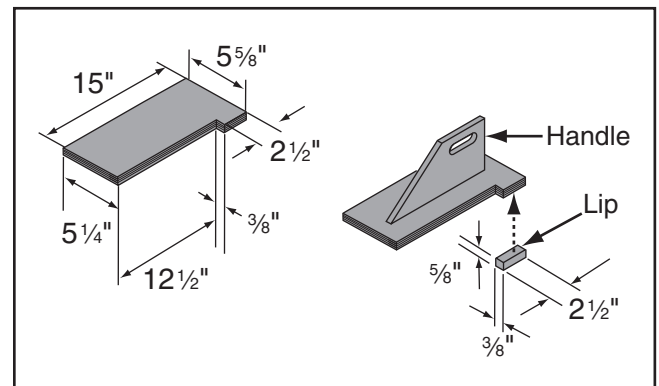
**Note:** We recommend cutting the hardwood board oversize, then jointing and planing it to the correct size to make sure the board is square and flat. Only use furniture grade plywood or kiln dried hardwood to prevent warping.

2. Pre-drill and countersink eight pilot holes  $\frac{3}{8}$ " from the bottom of the 3" wide board, then secure the boards together with eight #8 x  $1\frac{1}{4}$ " wood screws, as shown in **Figure 103**.



**Figure 103.** Location of pilot holes.

3. Using the  $\frac{3}{4}$ " material you used in the previous steps, cut out pieces for the push block per the dimensions shown in **Figure 104**; for the handle, cut a piece 10" long by 5"–9" high and shape it as desired to fit your hand.



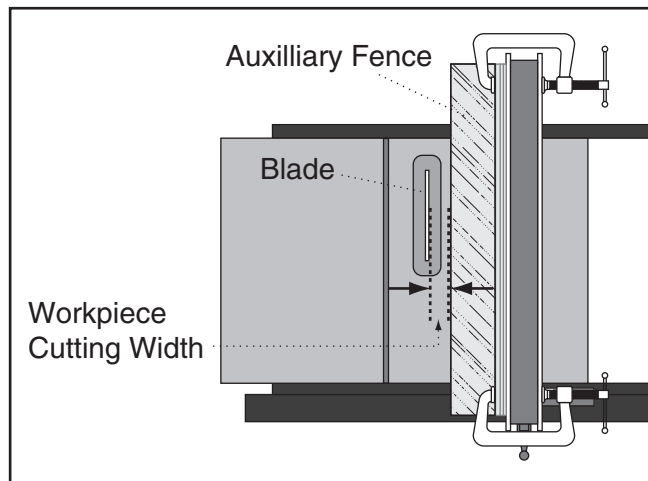
**Figure 104.** Push block dimensions and construction.

4. Attach the handle to the base with #8 x  $1\frac{1}{4}$ " wood screws, and attach the lip to the base with cyanoacrylate type wood glue.



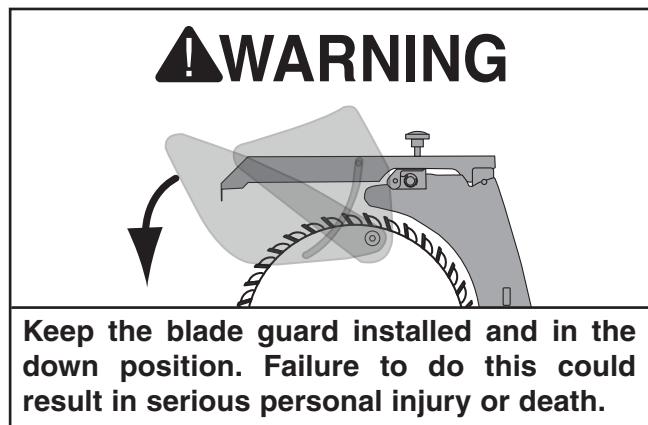
## Using the Auxiliary Fence and Push Block

1. Place the auxiliary fence on the table and clamp it to the fence at both ends, then adjust the distance between the auxiliary fence and the blade—this determines how wide the workpiece will be ripped (see **Figure 105**).

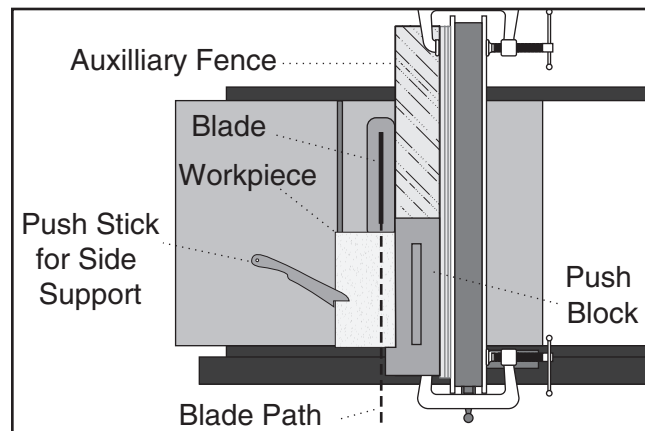


**Figure 105.** Adjusting ripping distance between blade and auxiliary fence.

2. Install the blade guard, then remove the spreader pawls, as explained on **Page 36**, so they do not interfere with the push block lip.



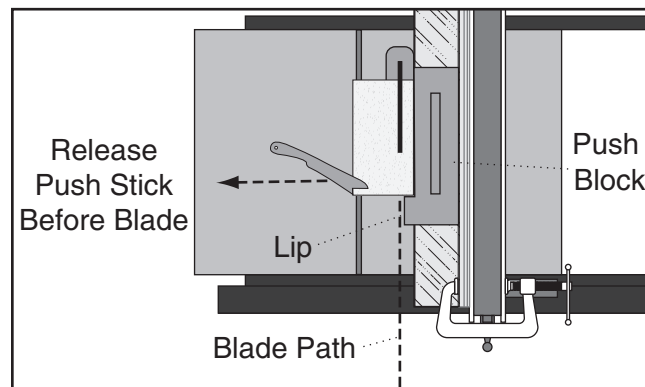
3. Place the workpiece 1" behind the blade and evenly against the table and the auxiliary fence, (see **Figure 106**).



**Figure 106.** Push block in position to push workpiece through blade.

4. Turn the saw **ON**, then begin ripping the workpiece using a push stick for side support.

As the workpiece nears the end of the cut, place the push block on the auxiliary fence with the lip directly behind the workpiece, then release the push stick just before it is even with the blade (see **Figure 107**).



**Figure 107.** Ripping with push block.

Guide the workpiece the rest of the way through the cut with the push block, then re-install the pawls on the spreader when cutting operations are finished.

## ! WARNING

Turn the saw **OFF** and allow the blade to come to a complete stop before removing the cut-off piece. Failure to follow this warning could result in serious personal injury.



# Outfeed & Support Tables

One of the best accessories for improving the safety and ease of using a table saw is simply placing a large table (outfeed table) behind the saw to catch the workpiece (see **Figure 108**). Additionally, another table to the left of the saw (support table) can also help support large workpieces so they can be cut safely and accurately.



**Figure 108.** Example of outfeed & support tables.

# Crosscut Sled

A crosscut sled (see **Figure 109**) is a fantastic way to improve the safety and accuracy of crosscutting on the table saw. Most expert table saw operators use a crosscut sled when they have to crosscut a large volume of work, because the sled offers substantial protection against kickback when crosscutting.



**Figure 109.** Example of crosscut sled.



# SECTION 6: ACCESSORIES

## **!WARNING**

Some aftermarket accessories can be installed on this machine that could cause it to function improperly, increasing the risk of serious personal injury. To minimize this risk, only install accessories recommended for this machine by Grizzly.

## **NOTICE**

Refer to the newest copy of the Grizzly Catalog for other accessories available for this machine.

**Call 1-800-523-4777 To Order**

**H8084—Rear Tool Box for G0605X1/G0606X1**  
**H8085—Front Tool Box for G0605X1/G0606X1**  
Made specially to fit the G0605X1/G0606X1 saws. These heavy-duty tool boxes feature powder coated paint and ball bearing slides. Model H8084, 32"L x 22½"H x 15"D; Model H8085, 25"L x 22½"H x 15"D.



**Figure 110.** Model H8084, H8085 Tool Boxes.

**T21878—Phenolic Dado Insert for G0605X1/G0606X1/G0696X/G0697X**

**T21879—Zero Clearance Insert for G0605X1/G0606X1/G0696X/G0697X**

Made especially for the G0605X1/G0606X1/G0696X/G0697X table saw. Height is easily adjustable. Special phenolic material.

**G4173—Baby Power Feeder 110V**  
**G4176—¼ HP Power Feeder 110V**  
**G4179—½ HP Power Feeder 220V**  
**G4181—1 HP Power Feeder 220V**

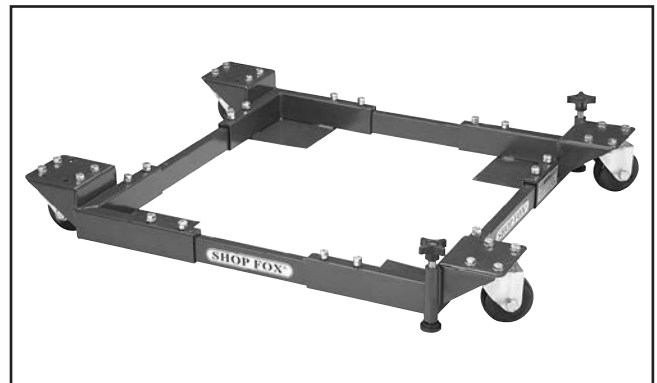
Installing a power feeder on your table saw will make repetitive cuts much easier and safer. Can be installed on nearly any table saw. Easy to adjust wherever needed, including out of the way when not needed! A must for any production shop.



**Figure 111.** G4179 Power Feeder.

**G7314Z—Heavy-Duty SHOP FOX® Mobile Base**

This patented base is the most stable on the market with outrigger type supports. Adjusts from 19" x 20½" to 29½" x 29½". 700 lb. capacity. Weighs 47 lbs.



**Figure 112.** G7314Z SHOP FOX® Mobile Base.



### H8875—26" Wide Outfeed Roller System

### G1317—37" Wide Outfeed Roller System

These unique roller systems fold down easily without tools and snap up in place quickly when needed. Both units have a double level system which lets you set the rollers either in line with the table or slightly below it.



Figure 113. Outfeed roller system.

### G5562—SLIPIT® 1 Qt. Gel

### G5563—SLIPIT® 12 oz Spray

### G2871—Boeshield® T-9 12 oz Spray

### G2870—Boeshield® T-9 4 oz Spray

### H3788—G96® Gun Treatment 12 oz Spray

### H3789—G96® Gun Treatment 4.5 oz Spray



Figure 114. Recommended products for protecting unpainted cast iron/steel part on machinery.

**Call 1-800-523-4777 To Order**

### H7583—Grizzly Tenoning Jig

Our fully adjustable tenoning jig handles stock up to 3¼" thick and features an adjustable bevel angle with a 90° to 75° range. The two large grip handles, adjustable guide bar, multi-position control levers, and extra large clamping handwheel will ensure accurate and repeatable results. A top seller!

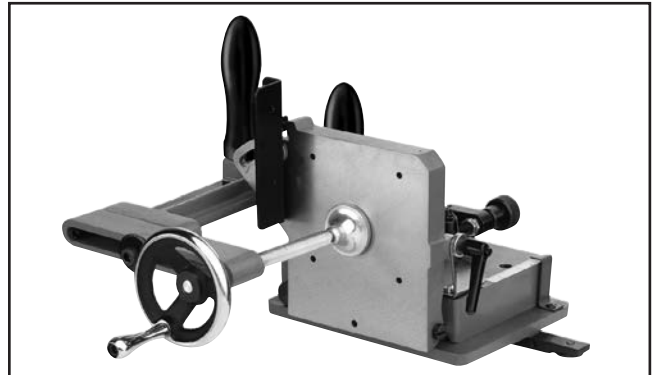


Figure 115. Model H7583 Tenoning Jig.

### T10113—Universal Overarm Blade Guard

Capture the dust that's thrown above the saw by the higher escape velocity of the spinning blade. This Universal Overarm Blade Guard is totally self supporting, so there's no complicated installation process. Just bolt it to your saw base for total stability. It also extends for saws with wide rip capacities and pivots out of the way for complete versatility. Approximate shipping weight: 75 lbs.



Figure 116. T10113 universal overarm blade guard.



# SECTION 7: MAINTENANCE

---



## Schedule

---

For optimum performance from your machine, follow this maintenance schedule and refer to any specific instructions given in this section.

### Daily Check:

- Inspect blades for damage or wear.
- Check for loose mounting bolts/arbor nut.
- Check cords, plugs, and switch for damage.
- Any other condition that could hamper the safe operation of this machine.
- Wipe the table clean after every use—this ensures moisture from wood dust does not remain on bare metal surfaces.
- Verify that the anti-kickback pawls return to their bottom-most position after pivoting.
- Verify that the spreader/riving knife are aligned with the blade (refer to **Page 68** to perform a quick check.)

### Weekly Maintenance:

- Wipe down the table surface and grooves with a lubricant and rust preventive such as SLIPIT®.
- Vacuum dust buildup from the motor housing and trunnions.
- Clean the pitch and resin from the saw blade with a cleaner like OxiSolv® Blade & Bit Cleaner.

### Monthly Maintenance:

- Check/tighten the belt tension (**Page 75**).
- Check lubrication of trunnion slides, worm gear, bevel gears, and mounting plate teeth, elevation leadscrew and rails (**Page 61**).

## Cleaning

---

Cleaning the Model G0605X1/G0606X1G0696X/G0697X is relatively easy. Vacuum excess wood chips and sawdust, and wipe off the remaining dust with a dry cloth. If any resin has built up, use a resin dissolving cleaner to remove it.

After cleaning, treat all unpainted cast iron and steel with a non-staining lubricant.

Occasionally it will become necessary to clean the internal parts with more than a vacuum. To do this, remove the table top and clean the internal parts with resin/pitch dissolver or mineral spirits and a stiff wire brush or steel wool. **DO NOT USE WATER—WATER WILL CAUSE CAST IRON TO RUST.**

Make sure the internal workings are dry before using the saw again, so that wood dust will not accumulate. If any essential lubrication is removed during cleaning, re-lubricate those areas.

## Unpainted Cast Iron

---

Protect the unpainted cast iron surfaces on the table by wiping the table clean after every use—this ensures moisture from wood dust does not remain on bare metal surfaces.

Keep tables rust-free with regular applications of products like G96® Gun Treatment, SLIPIT®, or Boeshield® T-9 (see **Section 5: Accessories** on **Page 58** for more details).



# Lubrication

It is essential to clean components before lubricating them because dust and chips build up on lubricated components and make them hard to move. Simply adding more grease to them will not yield smooth moving components.

Clean the components in this section with an oil/grease solvent cleaner, such as shown on **Page 19** of this manual, and shop rags.

If you thoroughly clean the components in this section before lubricating them, the result will be silky smooth movement when turning the handwheels, which will result in much higher enjoyment on your part!

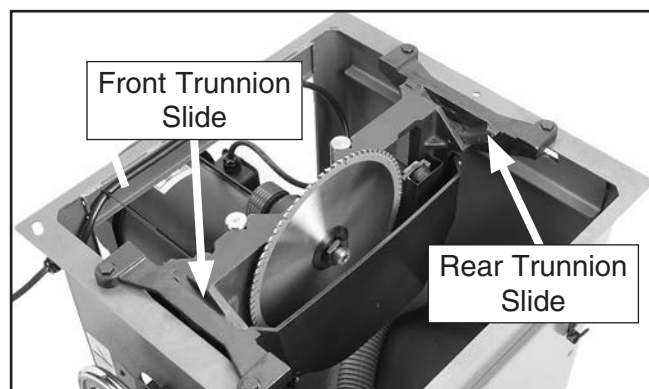
**The following are the main components that need to be lubricated:**

- Trunnion Slides
- Worm Gear, Bevel Gears, and Mounting Plate Teeth
- Elevation Leadscrew and Rails

**DISCONNECT THE POWER BEFORE PERFORMING LUBRICATION!** After lubrication is complete, recalibrate the digital readout (refer to procedure on **Page 74**) before operating the table saw.

## Trunnion Slides

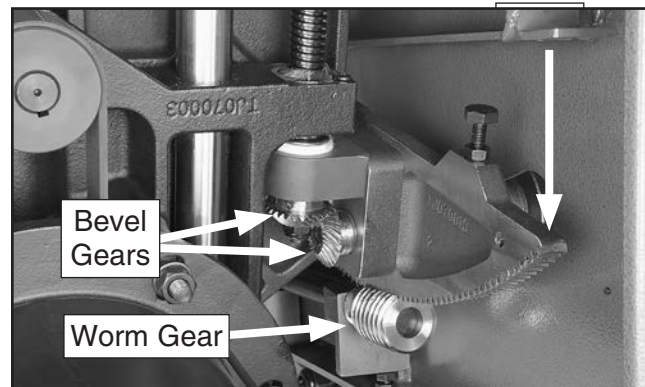
Check every month. Clean out the front and rear trunnion slides with mineral spirits and a rag, then apply lithium grease into each groove. Move the blade tilt back-and-forth to spread the grease (see **Figure 117**).



**Figure 117.** Trunnion slides and tilt leadscrew.

## Worm Gear, Bevel Gears, and Mounting Plate Teeth

Check every month. Use a wire brush and mineral spirits to clean away any built up grime and debris from the worm gear, bevel gear, and mounting plate teeth (see **Figure 118**).

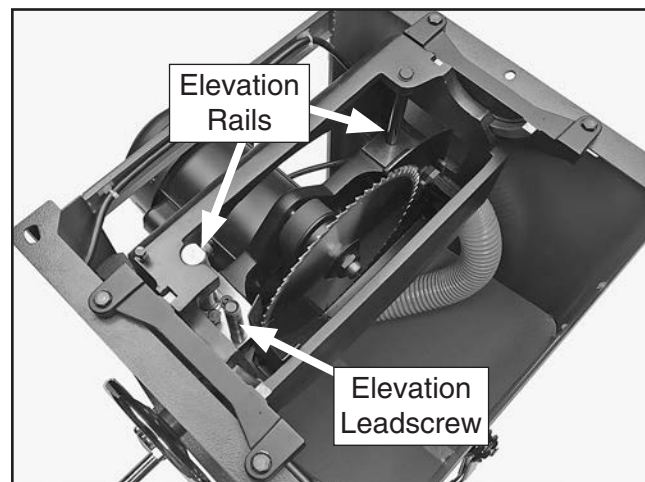


**Figure 118.** Worm gear, bevel gears, and mounting plate teeth.

Use a brush to apply a thin coat of white lithium grease to the worm gear, bevel gears, and mounting plate teeth.

## Elevation Leadscrew and Rails

Check every month. Clean away any built up grime and debris with a wire brush and mineral spirits from the elevation rails and elevation leadscrew (see **Figure 119**).



**Figure 119.** Bevel gears, elevation leadscrew and rails

Use a brush to apply lithium grease to the elevation leadscrew. Brush a small amount of grease (or oil) onto the elevation rails and wipe them down with a rag. The goal is to spread a thin film over the rails to help protect them from rust.




# SECTION 8: SERVICE

Review the troubleshooting and procedures in this section if a problem develops with your machine. If you need replacement parts or additional help with a procedure, call our Technical Support at (570) 546-9663.

**Note:** Please gather the serial number and manufacture date of your machine before calling.

## Troubleshooting

Symptom	Possible Cause	Possible Solution
Motor does not start. 	<ol style="list-style-type: none"> <li>1. Switch disabling lock installed.</li> <li>2. Motor connection wired incorrectly.</li> <li>3. Contactor not energized/has poor contacts.</li> <li>4. Break or short in wiring; or loose connections.</li> <li>5. Power supply switched off/has incorrect voltage.</li> <li>6. Thermal overload relay in mag switch tripped.</li> <li>7. Start capacitor has blown (G0605X1/G0696X only).</li> <li>8. Centrifugal switch at fault (G0605X1/G0696X only).</li> <li>9. Machine wired out of phase (G0606X1/G0697X only).</li> <li>10. Phase converter (if used) wild wire connected wrong (G0606X1/G0697X only).</li> </ol>	<ol style="list-style-type: none"> <li>1. Remove switch disabling lock.</li> <li>2. Wire motor correctly (refer to inside junction box cover or manual).</li> <li>3. Test all legs for power, test field coil and replace if at fault.</li> <li>4. Trace/replace broken or corroded wires; fix loose connections.</li> <li>5. Switch power supply on/verify voltage.</li> <li>6. Allow relay/motor to cool. If necessary, press reset button inside switch.</li> <li>7. Test/replace if at fault.</li> <li>8. Adjust/replace centrifugal switch.</li> <li>9. Swap two power incoming power leads (see <b>Page 12</b>).</li> <li>10. Connect wild wire to line without transformer or sensitive electronics.</li> </ol>
Machine operates in reverse.	<ol style="list-style-type: none"> <li>1. Power connections wired out of phase (G0606X1/G0697X only).</li> </ol>	<ol style="list-style-type: none"> <li>1. Swap two incoming power leads (see <b>Page 12</b>).</li> </ol>
Machine has excessive vibration or noise.	<ol style="list-style-type: none"> <li>1. Slight blade wobble.</li> <li>2. Arbor nut is loose/obstructed by debris.</li> <li>3. Arbor pulley loose.</li> <li>4. Loose tilt handwheel.</li> <li>5. Casting at fault.</li> <li>6. Motor fan rubbing on fan cover.</li> <li>7. Motor mounting loose.</li> <li>8. Belt worn or damaged.</li> <li>9. Belt(s) slapping cover.</li> <li>10. Pulley loose or not in alignment; shaft bent.</li> <li>11. Machine incorrectly mounted on floor.</li> <li>12. Arbor bearings at fault.</li> <li>13. Motor bearings worn or damaged.</li> </ol>	<ol style="list-style-type: none"> <li>1. Use a blade stabilizer.</li> <li>2. Remove and clean, then tighten arbor nut.</li> <li>3. Retighten/replace arbor pulley with shaft and thread locking liquid.</li> <li>4. Tighten the tilt handwheel lock knob.</li> <li>5. Trunnion/geared bearing housing is loose or cracked; tighten or replace.</li> <li>6. Fix/replace fan cover; replace loose or damaged fan.</li> <li>7. Tighten mounting bolts/nuts; use thread locking fluid.</li> <li>8. Replace belt (see <b>Page 76</b>).</li> <li>9. Tighten belt(s).</li> <li>10. Replace worn pulley, key, and shaft, and realign.</li> <li>11. Level/shim base; tighten/adjust mounting hardware or feet.</li> <li>12. Replace arbor housing bearings; replace arbor.</li> <li>13. Replace motor bearings or replace motor.</li> </ol>



Symptom	Possible Cause	Possible Solution
Handwheel binds or is difficult to move.	<ol style="list-style-type: none"> <li>1. Lock knob is engaged.</li> <li>2. Handwheel shaft pins are wedged.</li> <li>3. Handwheel is inserted too far.</li> <li>4. Too much engagement between the worm gear &amp; trunnion</li> </ol>	<ol style="list-style-type: none"> <li>1. Loosen lock knob.</li> <li>2. Remove handwheel and adjust shaft pins.</li> <li>3. Remove handwheel and adjust key.</li> <li>4. Adjust worm gear engagement.</li> </ol>
Blade does not reach 90 degrees.	<ol style="list-style-type: none"> <li>1. Pointer or scale calibrated incorrectly.</li> <li>2. 90 Degree stop bolt is out of adjustment.</li> </ol>	<ol style="list-style-type: none"> <li>1. Calibrate pointer/scale at true 90 degrees (see <b>Page 64</b>).</li> <li>2. Adjust 90 degree stop bolt (see <b>Page 64</b>).</li> </ol>
Blade does not reach 45 degrees.	<ol style="list-style-type: none"> <li>1. Pointer or scale calibrated incorrectly.</li> <li>2. 45 Degree stop bolt is out of adjustment.</li> <li>3. Sawdust is built up in front trunnion.</li> </ol>	<ol style="list-style-type: none"> <li>1. Calibrate pointer/scale at true 45 degrees (<b>Page 64</b>).</li> <li>2. Adjust 45 degree stop bolt (see <b>Page 65</b>).</li> <li>3. Check for sawdust in trunnions, clean and re-lubricate as necessary.</li> </ol>
Blade too close to insert.	<ol style="list-style-type: none"> <li>1. Blade position on arbor is incorrect.</li> <li>2. Table mounting position is not centered.</li> </ol>	<ol style="list-style-type: none"> <li>1. Verify that blade arbor washers are correct and in the required position.</li> <li>2. Loosen table mounting bolts, adjust table position, then realign the blade.</li> </ol>
Blade will not go beneath table surface.	<ol style="list-style-type: none"> <li>1. Handwheel shaft pins are wedged.</li> <li>2. Roll pin/setscrew in worm gear contacting geared trunnion.</li> <li>3. Handwheel key is inserted too far.</li> </ol>	<ol style="list-style-type: none"> <li>1. Remove handwheel and adjust shaft pins.</li> <li>2. Tighten roll pins and setscrews in the worm gear.</li> <li>3. Remove handwheel and adjust key.</li> </ol>
Blade will not move up or down.	<ol style="list-style-type: none"> <li>1. Set screw on worm gear is loose/missing.</li> <li>2. Handwheel shaft key is missing.</li> </ol>	<ol style="list-style-type: none"> <li>1. Tighten or replace set screw.</li> <li>2. Replace key.</li> </ol>
Workpiece burns or binds when feeding.	<ol style="list-style-type: none"> <li>1. Riving knife not correctly aligned with blade.</li> <li>2. Spreader not correctly aligned with blade.</li> <li>3. Fence not parallel with blade (pressure at blade backside).</li> <li>4. Blade is warped or damaged.</li> <li>5. Too many teeth on blade for cutting type.</li> </ol>	<ol style="list-style-type: none"> <li>1. Adjust riving knife into alignment with blade (see <b>Page 69</b>).</li> <li>2. Adjust spreader into alignment with blade (see <b>Page 69</b>).</li> <li>3. Adjust fence parallel with blade (see <b>Page 71</b>).</li> <li>4. Replace blade (<b>Page 34</b>).</li> <li>5. Change blade to one with fewer teeth.</li> </ol>
Too much sawdust blown back toward operator.	<ol style="list-style-type: none"> <li>1. Blade guard has been removed.</li> <li>2. Too many air leaks in cabinet for proper dust collection.</li> <li>3. Dust collection system clogged; too weak.</li> <li>4. Fence not parallel with blade (pressure at blade backside).</li> <li>5. Miter slot/fence not parallel with blade at 90° and 45°.</li> </ol>	<ol style="list-style-type: none"> <li>1. Re-install blade guard for maximum safety and dust control.</li> <li>2. Seal leaks in cabinet or around dust chute.</li> <li>3. Remove clog; revise ducting layout for improved suction.</li> <li>4. Adjust fence parallel with blade (see <b>Page 71</b>).</li> <li>5. Adjust table/trunnions so miter slot is parallel with blade at 90° and 45° (see <b>Page 66</b>).</li> </ol>



# Blade Tilt Stops

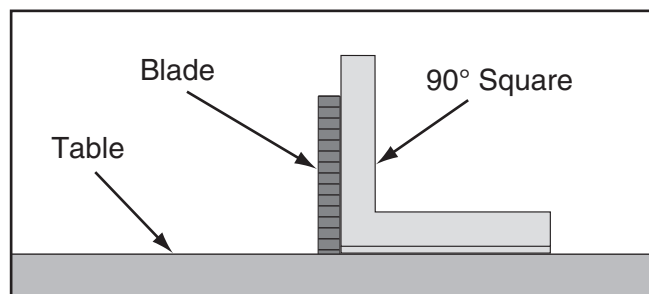
The table saw features bolts that stop the blade tilt exactly at 45° and 90° when using the handwheel. These stops have been set at the factory and should require no adjustments, unless you notice that your cuts are not accurate.

**Note:** The tilt scale reads "0" when the blade is 90° to the table.

Tools Needed	Qty
90° Square .....	1
45° Square .....	1
Hex Wrench 4mm.....	1
Wrench 13mm .....	1

## Setting 90° Stop Bolt

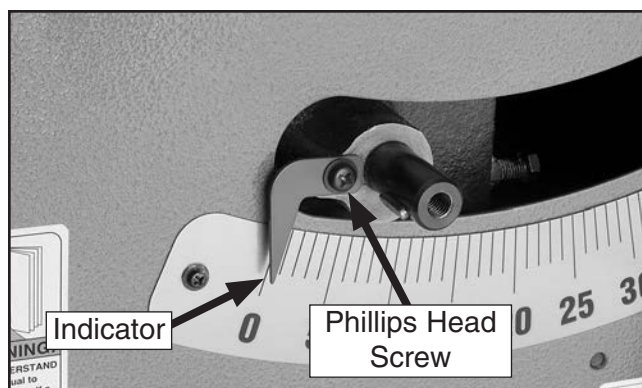
1. DISCONNECT SAW FROM POWER!
2. Raise the blade as high as it will go, then tilt it toward 0° until it stops and cannot be tilted any more.
3. Place a 90° square against the table and blade so it contacts the blade evenly from bottom to top, as shown in **Figure 120**. Make sure a blade tooth does not obstruct the placement of the square.



**Figure 120.** Checking blade at 90°.

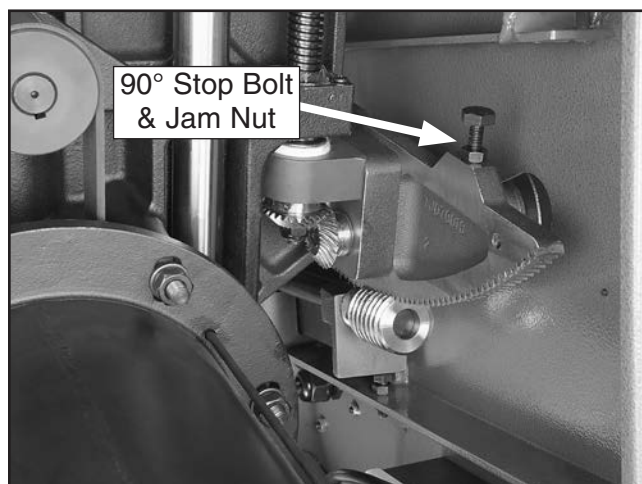
—If the blade is 90° to the table, then adjustments do not need to be made. Make sure the tilt indicator arrow shown in **Figure 121** points to the 0° mark on the scale. If it does not, remove the blade height lock knob, loosen the blade height handwheel set screw and remove the handwheel.

Adjust the indicator position by loosening the Phillips head screw, moving the indicator, then tightening the screw and re-installing the handwheel. Proceed to **Setting 45° Stop Bolt** on **Page 65**.



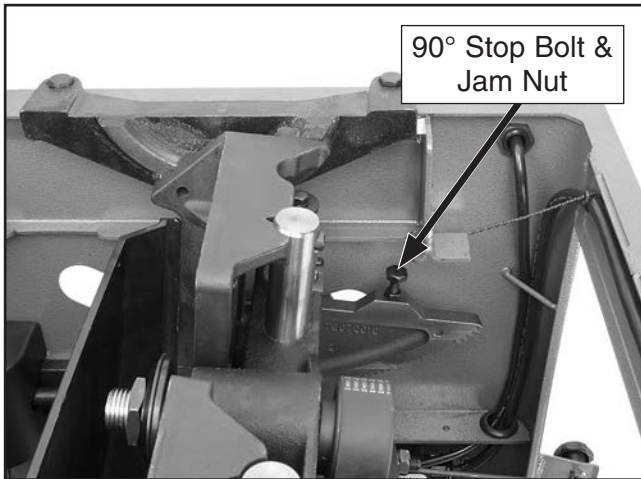
**Figure 121.** Tilt indicator arrow.

- If the blade is not 90° to the table, you will need to adjust the 90° stop screw. Proceed to the next step.
4. Tilt the blade to about 5°, so there is room for the stop bolt to move.
  5. Open the motor access cover, loosen the jam nut shown in **Figures 122–123**, adjust the stop bolt up or down according to how far off the blade was from 90°, then repeat **Step 3** until the blade stops at 90°.



**Figure 122.** 90° stop bolt and jam nut.



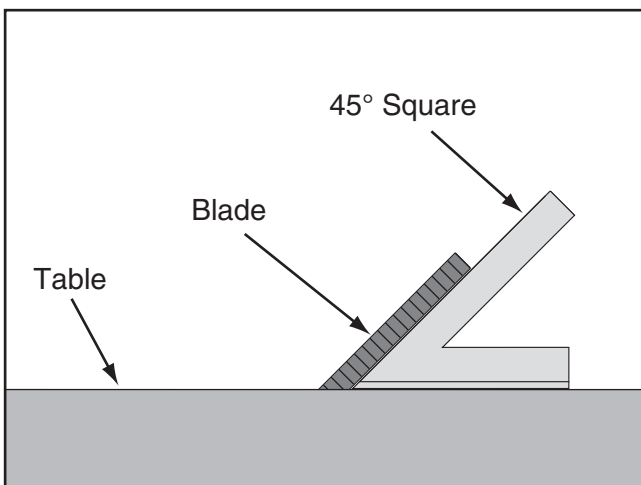


**Figure 123.** 90° stop bolt and jam nut (table removed for clarity).

6. Tighten the jam nut, then close the motor cover.

### Setting 45° Stop Bolt

1. DISCONNECT SAW FROM POWER!
2. Raise the blade as high as it will go, then tilt it towards 45° until it stops and cannot be tilted any more.
3. Place a 45° square against the table and blade so it contacts the blade evenly from bottom to top, as shown in **Figure 124**. Make sure a blade tooth does not obstruct the placement of the square.

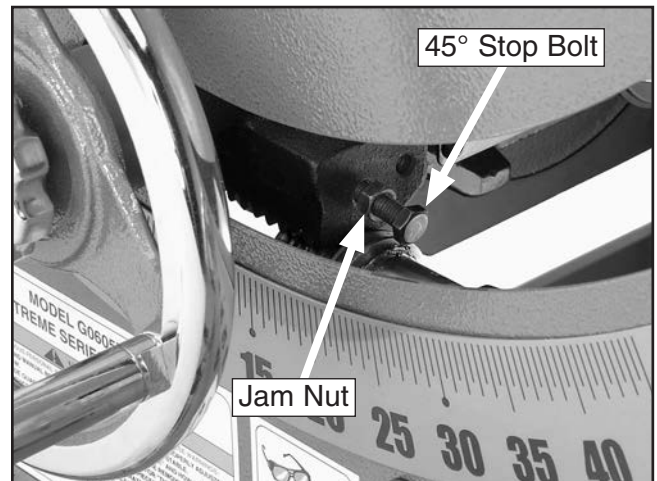


**Figure 124.** Checking blade at 45°.

—If the blade is 45° to the table, then adjustments do not need to be made.

—If the blade is not 45° to the table, you will need to adjust the 45° stop screw. Proceed to the next step.

4. Tilt the blade to 20°, so there is room for the stop bolt to move.
5. Loosen the jam nut on the 45° stop bolt (see **Figure 125**) with a 13mm wrench, then adjust the stop bolt up or down according to how far off the blade was from 45°.



**Figure 125.** 45° stop bolt and jam nut.

6. Continue adjusting the stop bolt until it contacts the cabinet when the blade is at 45°, then tighten the jam nut.
7. Reconnect the power, then recalibrate the digital readout (refer to procedure on **Page 74**) before operating the table saw.



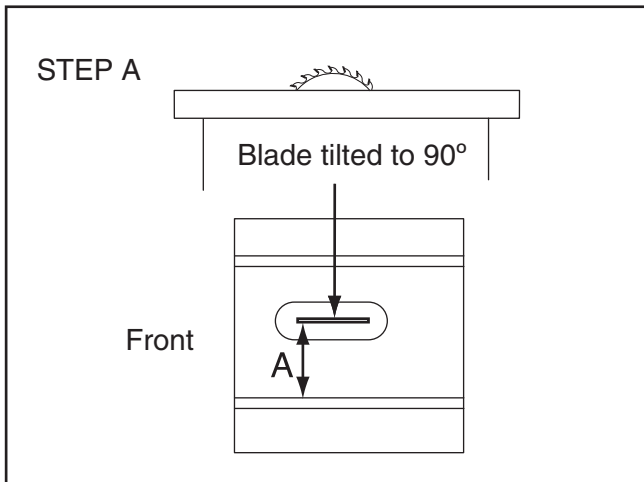
# Miter Slot to Blade Parallelism

Your table saw will give the best results if the miter slot is parallel with the blade. If these components are not exactly parallel with each other, your cuts and your finished work will be lower in quality, but more importantly, the risk of kickback will be increased.

Tools Needed	Qty
Adjustable Square .....	1
Metal Shim Stock .....	As Needed
Marker .....	1
Wrench 17mm.....	1

## To adjust the blade parallel with the miter slot:

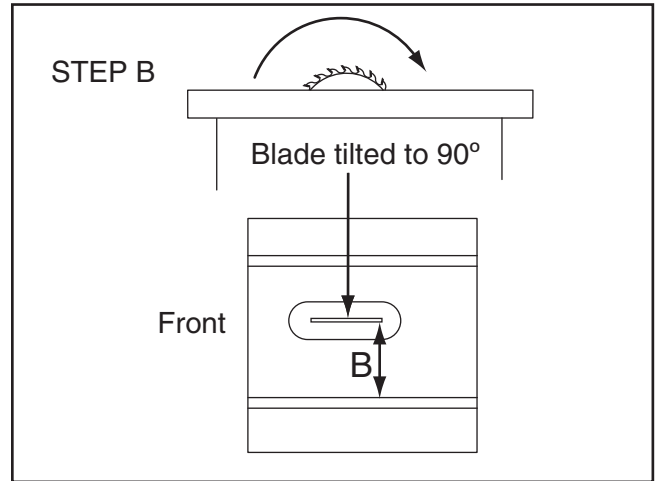
1. DISCONNECT SAW FROM POWER!
2. Tilt the blade to 90°.
3. Measure from the miter slot to a carbide tip on the blade, as shown in **Figure 126**.



**Figure 126.** Measuring distance from miter slot to carbide tip of blade.

4. Mark the carbide tip with a marker where you made this measurement.
5. Rotate the marked blade tip to the other end of the table insert.

6. Compare the distance from the marked blade tip to the miter slot, as shown in **Figure 127**.

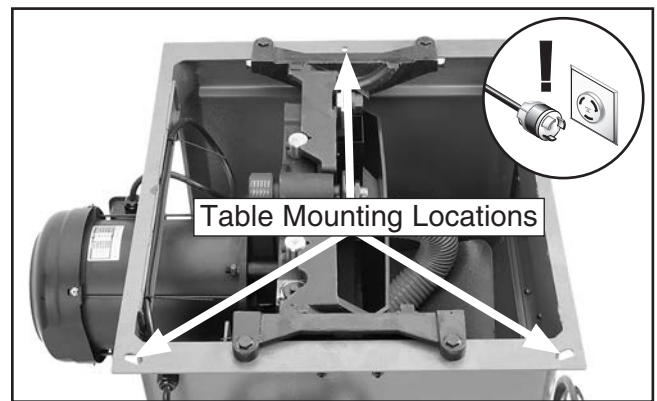


**Figure 127.** Measuring distance from miter slot to carbide tip on opposite side of table insert.

—If the distance between the blade tip and the miter slot is not the same on both sides of the table insert, the table will need to be adjusted. Proceed to **Step 7**.

—If the blade tip measurement is the same on both sides, go to **Step 8**.

7. To adjust the table, loosen the three bolts in the table mounting locations (see **Figure 128**) and lightly tap the table in the direction needed to square the table to the blade. Repeat **Steps 2–6** until the blade and miter slot are parallel. Do not forget to tighten the table mounting bolts when finished.

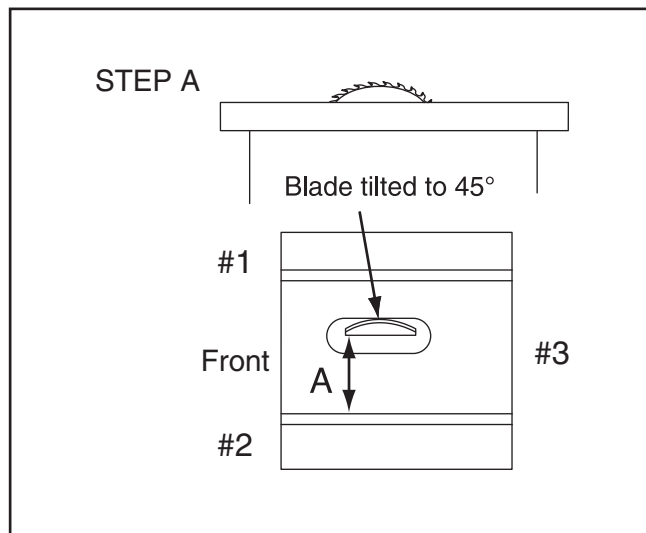


**Figure 128.** Table mounting bolt holes (table top removed for clarity).

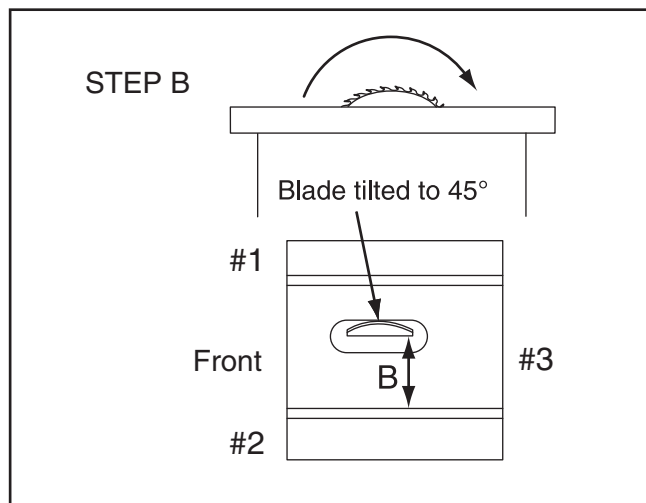


8. Tilt the blade to 45° and repeat **Steps 3–6**.
- If the blade is still parallel with the miter slot, continue onto the **Blade Alignment** procedure.
  - If the blade was parallel with the miter slot at 90° but not at 45°, one end of the table will need to be shimmed higher with metal shim stock.

9. Loosen the three table mounting bolts.
10. Refer to **Figures 129–130** for shim placement. If the distance of A is shorter than B, shim(s) will need to be placed under corners #1 and #2. If the distance of B is shorter than A, shim(s) will need to be placed under corner #3. Very thin shim stock works well.



**Figure 129.** Shim procedure diagram A.



**Figure 130.** Shim procedure diagram B.

11. Tighten one bolt a small amount and then repeat with the others, tightening each down the same amount. Continue this process with all the bolts, tightening them a little each time until they are all secure.
12. Now recheck the blade to the miter slot at 90° and 45° by repeating **Steps 3-6**.
- If the distance of A and B are equal, continue to **Step 13**, then go to **Blade Alignment**.
  - If the distances are still off, repeat **Steps 9–11**.
13. Once the miter slot is adjusted to the blade, recheck all measurements and be sure the table mounting bolts are secure. Also, if you remove the table in the future, note the shim placements and reassemble them exactly how they came apart.
14. Reconnect the power, then recalibrate the digital readout (refer to procedure on **Page 74**) before operating the saw.

## Blade Alignment

If the blade contacts the standard table insert when raised or tilted, the blade must be aligned.

Tools Needed	Qty
Wrench 14mm .....	1

### To adjust the blade alignment by moving the table:

1. DISCONNECT SAW FROM POWER!
2. Loosen the three table mounting bolts (**Page 66, Figure 128**) and adjust the table until the blade does not contact the insert. Tighten all the mounting bolts.
3. Make sure the blade does not contact the table insert when raised or tilted. Recheck parallelism of the blade to the miter slot (see **Page 66**). Adjust as necessary until the blade does not touch the insert.



# Spreader or Riving Knife Alignment

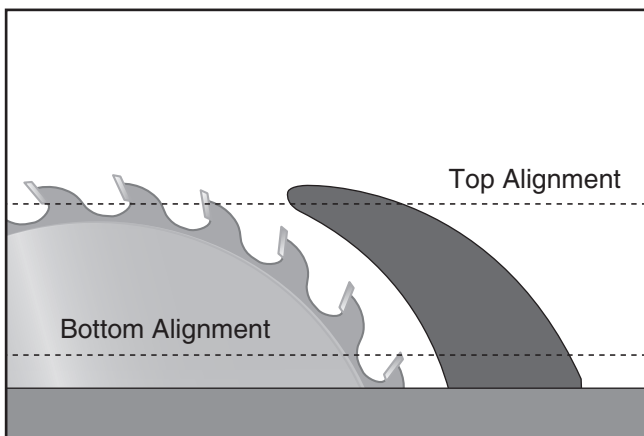
## Checking Alignment

The blade guard spreader and riving knife must be aligned with the blade when installed. If the spreader/riving knife is not aligned with the blade, then the workpiece will be forced sideways during the cut, which will increase the risk of kick-back.

Tools Needed	Qty
Straightedge .....	1

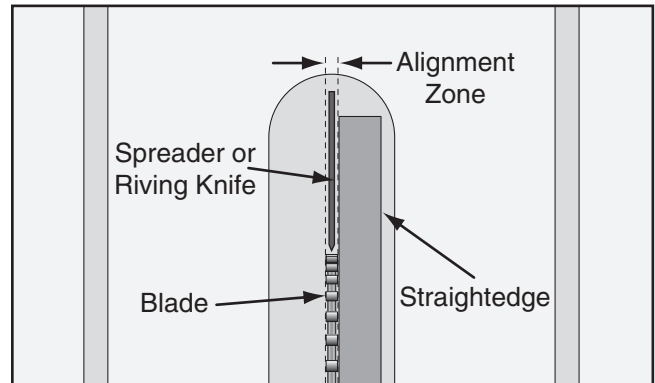
### To check the spreader/riving knife alignment:

1. DISCONNECT SAW FROM POWER!
2. Raise the saw blade to the maximum height so you have easy working access.
3. Check to make sure the blade is 90° to the table. Follow "Setting 90° Stop Bolt" instructions on **Page 64**.
4. Place the straightedge against the top and bottom of blade and spreader/riving knife, as shown in **Figure 131**.



**Figure 131.** Checking top and bottom riving knife parallelism with blade.

The spreader/riving knife should be parallel with the blade along its length at both positions and should be in the "Alignment Zone," as shown in **Figure 132**.



**Figure 132.** Spreader/riving knife alignment zone.

—If the spreader/riving knife is not parallel with the blade and inside the alignment zone, then it needs to be adjusted. Proceed to **Adjusting Alignment** instructions.

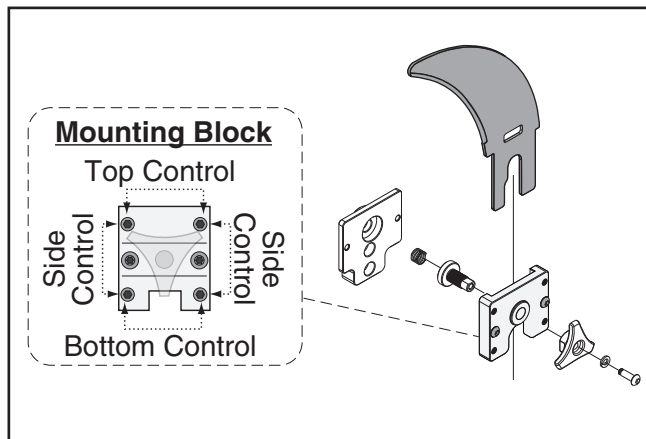
—If the spreader/riving knife is not parallel with the blade at either the top or bottom, it may be bent. Remove the spreader/riving knife and place it on a flat surface and check to see if the spreader/riving knife lays evenly along its length. If the spreader/riving knife does not lay evenly, proceed to **Adjusting Bent Spreader/Riving Knife** on **Page 69**.



## Adjusting Alignment

The spreader/riving knife mounts to a block that can be repositioned to correctly align the spreader/riving knife to the blade. The mounting block adjusts by turning the set screws in each corner of the block.

**Figure 133** shows the set screws associated with controlling the mounting block position.



**Figure 133.** Set screws for adjusting spreader/riving knife position.

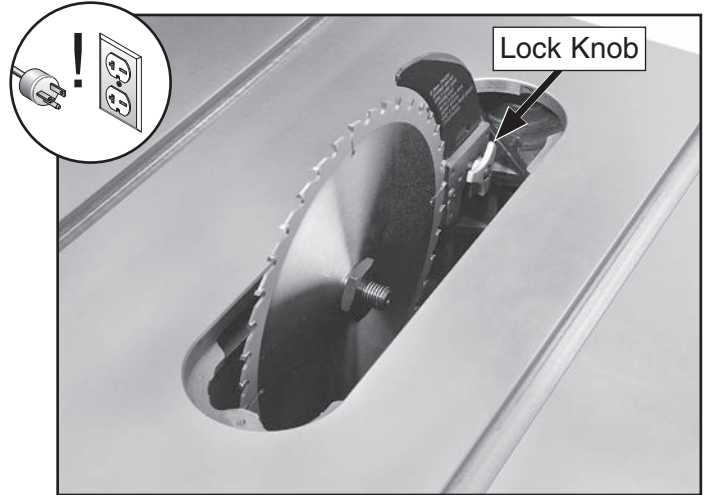
### Possible Tools Needed

	<b>Qty</b>
Hex Wrench 2.5mm.....	1
Hex Wrench 3mm.....	1

### To adjust the spreader/riving knife position:

1. DISCONNECT SAW FROM POWER!
2. Remove the table insert.
3. Loosen the two button head cap screws on the mounting block, then adjust the set screws on the block to move it in the necessary direction (see "Mounting Block" inset in **Figure 133**).

4. Tighten the lock knob (see **Figure 134**), then re-install the table insert.



**Figure 134.** Lock knob location.

5. Follow **Checking Alignment, Steps 1–4**, on **Page 68**.

—If the spreader/riving knife is in the alignment zone, no additional steps are necessary.

—If the spreader/riving knife is still not in the alignment zone, continue adjusting the set screws on the mounting block as necessary to correctly position the spreader/riving knife.

6. Tighten the two cap button head cap screws on the mounting block to secure the spreader/riving knife adjustment.

## Adjusting Bent Spreader/Riving Knife

1. DISCONNECT SAW FROM POWER!
2. Bend the spreader or riving knife by hand while installed, then follow **Steps 1–4** in **Checking Alignment** on **Page 68** to determine if it is parallel with the blade and inside the "Alignment Zone."

—If this does not work, remove it to straighten.

—If you cannot straighten it properly, replace it.



# Fence Adjustments

There are four main adjustments for the fence: 1) square, (2) height, (3) parallelism, and (4) clamping pressure.. Keep in mind that these adjustments are interconnected and some trial-and-error may be needed to achieve satisfactory results.

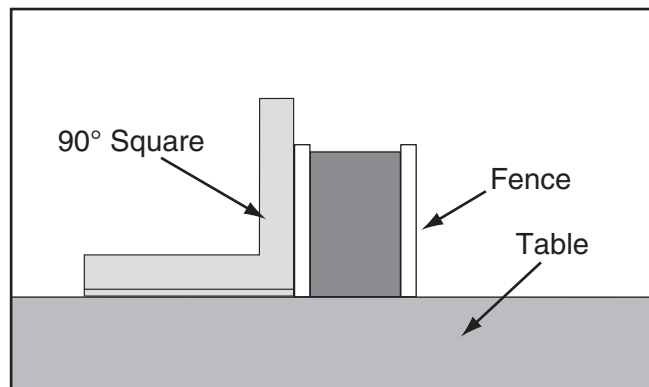
Tools Needed	Qty
Hex Wrench 4mm.....	1
Hex Wrench 6mm.....	1
Machinist's Square .....	1
Felt-Tipped Marker .....	1

## Square and Height

The fence face must be square to the table in order to produce square cuts. Also, the fence should be adjusted high enough off the table that it does not drag across the surface.

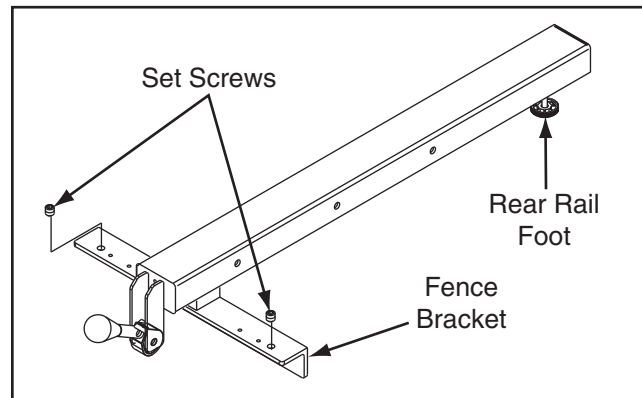
### To check/adjust the fence height and square-ness to the table:

1. DISCONNECT SAW FROM POWER!
2. Place a square on the table against the face of the fence (**Figure 135**) to check if the fence is square to the table.
  - If the fence is not square to the table, proceed to **Step 3**.
  - If the fence is square to the table, skip ahead to **Step 4**.



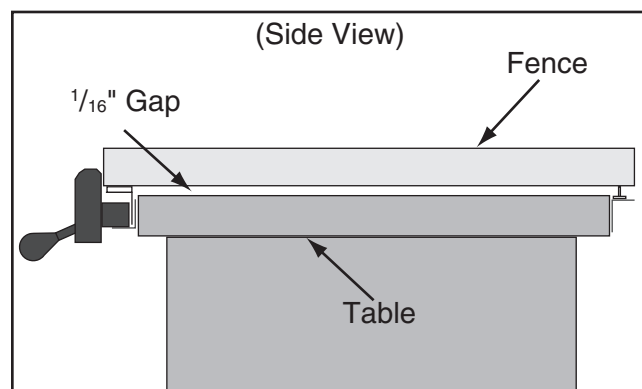
**Figure 135.** Checking if fence is square to table.

3. Adjust the set screws (**Figure 136**) on top of the fence bracket to ensure the fence face is 90° to the table.



**Figure 136.** Fence components used to adjust fence height and squareness to table.

4. Look at the gap between the fence and the table top.
  - If the gap is approximately 1/16" and even from the front of the table to the back (see **Figure 137**), then no additional adjustments are necessary. Proceed to **Clamping Pressure and Parallelism**.
  - If the gap is uneven, if the fence height is more than 1/8", or if the fence touches the table, then continue with **Step 5**.



**Figure 137.** Gap between fence and table approximately 1/16" from to back.

5. Adjust the fence height with the rear rail foot until the gap between the table and the fence is approximately 1/16" and even from the front of the table to the back.



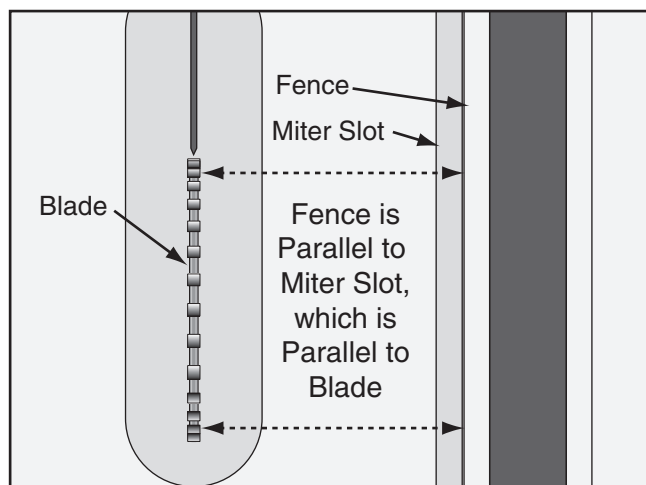
**Note:** If the front end of the fence needs to be adjusted up or down, use the set screws from **Figure 136**; however, turn them in even increments and recheck the squareness afterwards.

## Clamping Pressure and Parallelism

The fence clamping mechanism adjusts the clamping pressure to hold your fence securely and to position the fence parallel with the blade.

### To verify fence parallelism:

- Slide the fence along the rail.
  - If the fence drags across the table, loosen the hex nut on the foot at the rear of the fence and adjust the foot to raise the fence off of the table so the gap is approximately  $\frac{1}{16}$ " and even from the front of the table to the back (see **Figure 137** on **Page 70**). Tighten the hex nut on the foot to secure the foot in position.
- Slide the fence up against the right hand edge of the miter slot, lock it in place, then raise the blade above the insert. Using a fine ruler, examine how the fence lines up with the miter slot and the blade, as shown in **Figure 138**.

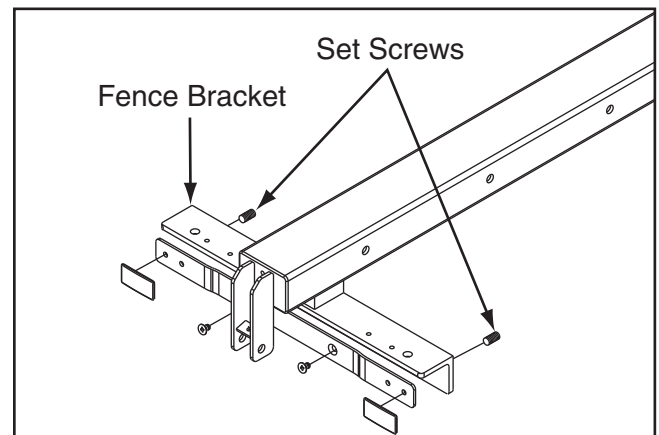


**Figure 138.** Checking fence parallelism with blade.

- If the fence and miter slot are parallel with the blade, as shown in **Figure 138**, no further adjustments need to be made.
- If the fence is not parallel with the blade/ miter slot, then you must adjust the fence parallel with the blade.
- If the miter slot is not parallel with the blade, you must follow the procedures described in **Miter Slot to Blade Parallelism** on **Page 66**.

### To adjust the fence clamping pressure and parallelism to the blade:

- DISCONNECT SAW FROM POWER!
- Remove the fence, equally adjust the set screws shown in **Figure 139**, then re-install the fence and check the clamping pressure. Re-adjust as needed until the fence will not move as pressure is applied against it.



**Figure 139.** Location of set screws used to adjust fence parallelism and clamping pressure.

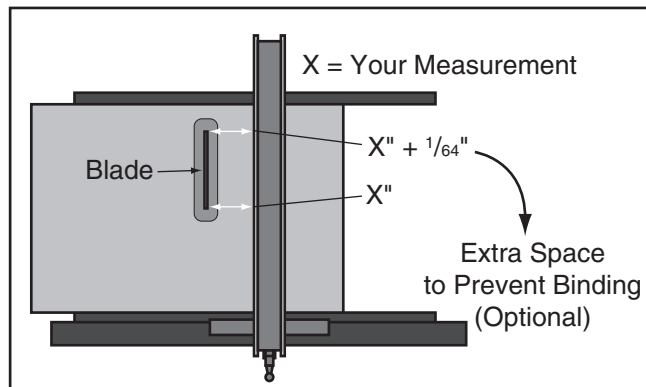
- Mount the fence on the rail again, move it approximately 4" away from the blade, and lock it in place.
- Measure the distance between the fence and the front of the blade, then mark the tooth that you measured from with a felt-tipped marker.



5. Rotate the blade 180° and recheck the distance between the fence and the blade tooth you marked in **Step 4** to ensure they are parallel (see **Figure 138** on **Page 71**).
6. Use trial-and-error to adjust the set screws so the fence is parallel to the blade and the clamping pressure is sufficient.

## Offsetting Fence

Some woodworkers prefer to offset the rear of the fence  $\frac{1}{64}$ " from the blade, as shown in **Figure 140**.

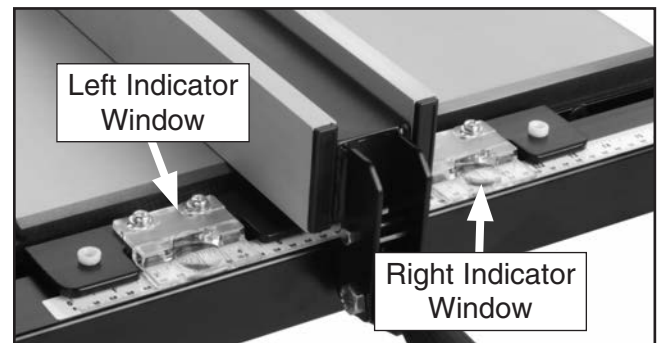


**Figure 140.** Adjusting fence with a  $\frac{1}{64}$ " offset.

The reason for this wider gap at the back side of the blade is to help prevent the chance of kickback and the blade burning the workpiece because a workpiece may be inconsistent. However, the trade-off is less accurate cuts, and if the fence is placed on the other side of blade for other table saw operations, the potential of workpiece burning and kickback can be increased. Whenever using a fence, make sure that if an offset has been adjusted in the fence alignment, you use the fence on the side of the blade where the offset creates the wide gap.

# Fence Scale Calibration

The fence scale indicator windows, shown in **Figure 141**, can be calibrated with the fence scale by loosening the two mounting screws and sliding it in the desired direction. The indicator window on the right side is used when the fence is positioned on the right side of the blade. The indicator window on the left side is used when the fence is positioned on the left side of the blade. **IMPORTANT:** Do not use the fence on the left side of the blade if it has been purposely offset, as described in **Offsetting Fence on this page**.



**Figure 141.** Example of fence indicator windows.

Tools Needed	Qty
Phillips Screwdriver .....	1
Scrap Piece of Wood.....	1

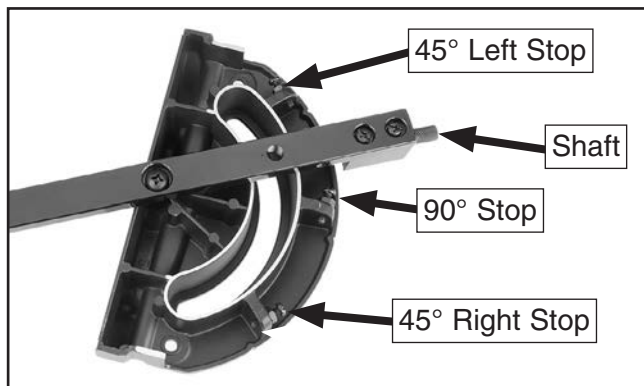
### To calibrate the fence scale indicator windows:

1. Position and lock the fence at 13", as indicated by the scale, then cut your scrap piece of wood.
2. Reposition and lock the fence at 12", as indicated by the scale.
3. Flip your scrap piece of wood over, placing the side that was cut in **Step 2** against the fence, then make your cut.
4. Measure the width of the freshly cut workpiece with a tape measure. The workpiece width should be exactly 12". If it is not, then adjust the indicator window to match the width of the workpiece.



# Miter Gauge Adjustments

The miter gauge is equipped with stop screws that allow you to easily adjust the miter gauge from 45° to the left, 90°, and 45° to the right (see **Figure 142**). The stop screws contact the shaft, which moves in or out of the way for adjustments.

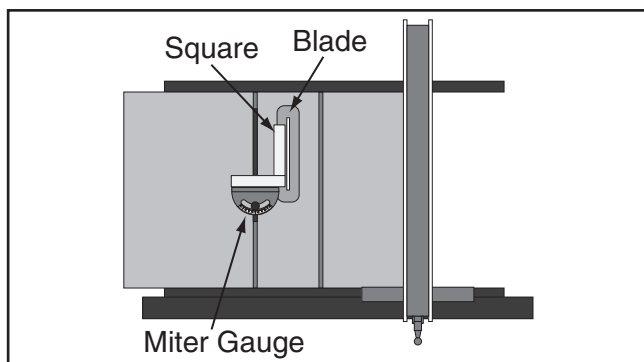


**Figure 142.** Miter gauge stops.

Tools Needed	Qty
Hex Wrench 2.5mm.....	1
Phillips Screwdriver .....	1
Square 90° and 45° .....	1 Each
Wrench 8mm .....	1

## Checking/Setting 90° Stops

1. DISCONNECT SAW FROM POWER!
2. Slide the miter gauge into the T-slot on the table, then push the sliding shaft all the way into the miter gauge.
3. Adjust the miter gauge so the 90° stop screw rests against the sliding shaft.



**Figure 143.** Checking 90° stop on miter gauge.

4. Place the 90° square evenly against the face of the miter gauge and the blade, as shown in **Figure 143**.

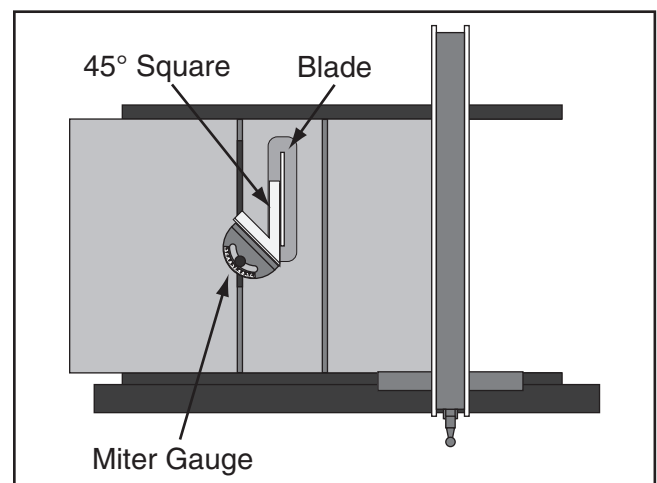
—If the square touches the miter body and the body of the blade (not the teeth) evenly at the same time, then it is square to the blade and the 90° stop is set correctly. No further adjustments are necessary.

—If the square does not touch the miter body and blade body evenly at the same time, then proceed to **Step 5**.

5. Loosen the hex nut (jam nut) that secures the 90° stop screw and adjust the stop screw until it is seated against the shaft while the square is evenly touching the miter body and the blade body, then tighten the hex nut.
6. Loosen the screw on the front of the miter bar, adjust the pointer to 0°, then tighten the screw.

## Checking/Setting 45° Stops

Follow the same process with the 45° stops that you followed with the 90°, except using a 45° square or adjustable square to verify that the miter body is 45° to the blade, as shown in **Figure 144**.



**Figure 144.** Checking 45° stop on miter gauge.



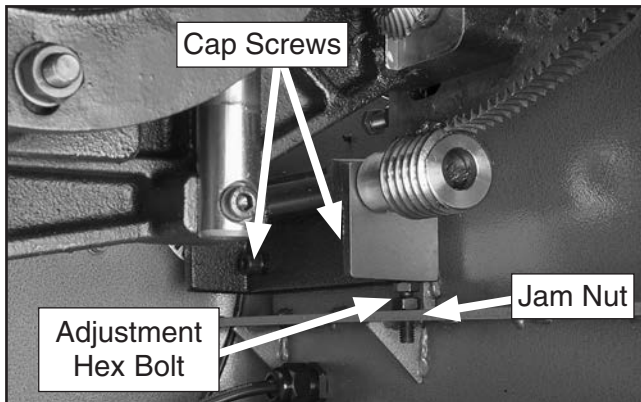
# Table Tilt Handwheel Backlash

The table tilt handwheel should move with very little backlash or slop when the saw is new. Over time the tilt gears may wear, increasing backlash. You can eliminate backlash by adjusting the tilt handwheel gears.

Tools Needed	Qty
Hex Wrench 6mm.....	1
Wrench 12mm .....	1
Wrench 13mm .....	1

## To adjust the table tilt gear backlash:

1. DISCONNECT SAW FROM POWER!
2. Turn the table tilt handwheel one way a couple turns, then turn it the other way to feel the backlash.
3. Unscrew the tap screws securing the angle sensor cover, then remove it, and loosen the two cap screws and the jam nut shown in **Figure 145**.



**Figure 145.** Table tilt handwheel adjustment.

4. While a helper tightens the adjustment hex bolt, turn the tilt handwheel back and forth. Tighten the hex bolt until you no longer feel any wobble or looseness when the handwheel is initially turned. Do not overtighten the gears or they will bind.
5. Tighten the jam nut and cap screws, re-install the angle sensor cover, then close the motor access cover.

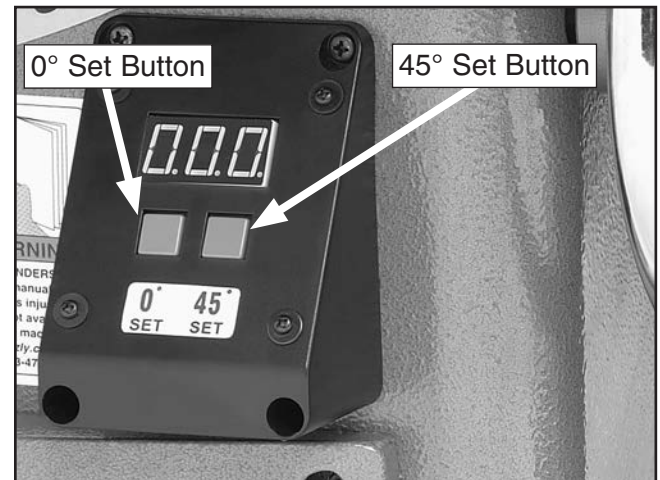
# Digital Readout Calibration

The digital readout displays the current blade angle. Only set the readout after verifying that the 90° and 45° blade tilt stops are correctly positioned.

## To calibrate the digital readout:

1. Ensure the power is connected and the 45° and 90° stop bolts are set (see **Blade Tilt Stops** starting on **Page 64**).
2. Move the blade angle to 90° and press the 0° SET button (**Figure 146**) for several seconds until the readout displays 0.00, or move the blade angle to 45° and press the 45° SET button until the readout displays 45.0.

**Note:** If the power is disconnected, the digital display will automatically reset to 0.00. Therefore, when you reconnect power, follow **Steps 1–2** above.



**Figure 146.** Digital readout.



# Belt Tension & Replacement

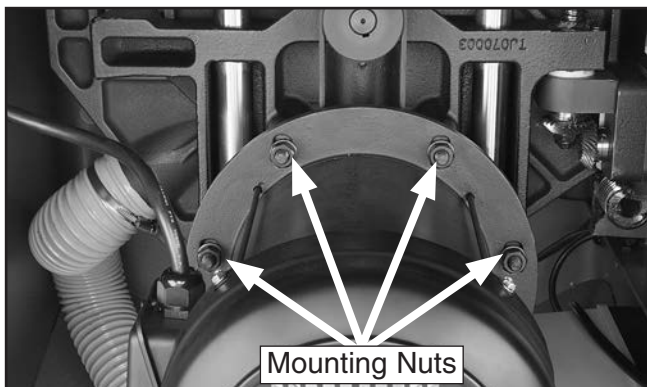
The belt stretches slightly as the saw is used. Most of the belt stretching will happen during the first 16 hours of use, but it may continue to gradually stretch with continued use.

To ensure optimum power transmission from the motor to the blade, the belt must be in good condition. Replace the belt if it becomes cracked, frayed, or glazed.

Tools Needed	Qty
Arbor Wrenches .....	2
Wood Block 10" Long 4x4 .....	1
Wrench or Socket 17mm .....	1
Wood Block 8" 2x6.....	1

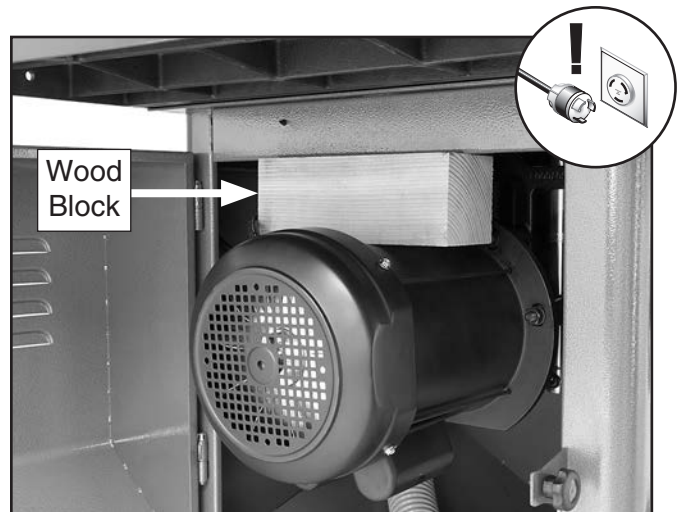
## Tensioning Belt

1. DISCONNECT SAW FROM POWER!
2. Use the blade height handwheel to lower the motor all the way down.
3. Loosen the four motor mounting hex nuts shown in **Figure 147** two turns, then place the 4x4 wood block on top of the motor, as shown in **Figure 148**.



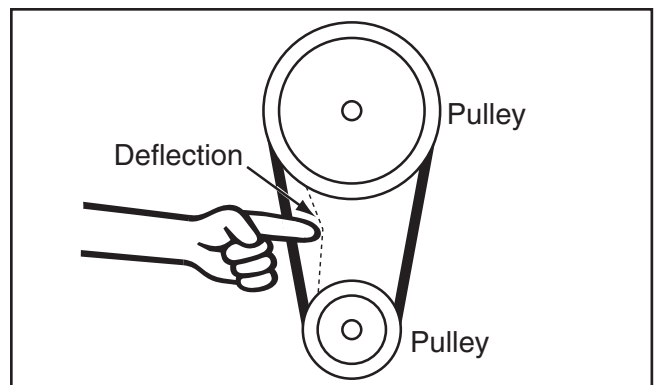
**Figure 147.** Motor mounting nuts.

4. Use the blade height handwheel to carefully tension the belt by moving the blade up. Do this slowly and take care not to apply too much pressure to the belt. **Note:** *Be careful not to damage the motor, and do not force it up farther when it becomes difficult to move the handwheel.*



**Figure 148.** Example of using wood block to tension belt.

5. Press the belt in the center to check belt tension. The belt is correctly tensioned when there is approximately  $\frac{1}{8}$ " deflection when it is pushed with moderate pressure, as shown in **Figure 149**.



**Figure 149.** Checking belt deflection.

—If there is more than  $\frac{1}{8}$ " deflection when the belt is pushed with moderate pressure, raise the motor upward.

## **NOTICE**

**Do not overtighten the belt. If you do, it could decrease the lifespan of the motor and arbor bearings.**

6. Tighten the motor mounting hex nuts, lower the motor, and remove the wood block.
7. Close the motor cover.



## Replacing Belt

1. DISCONNECT SAW FROM POWER!
2. Raise the motor all the way up, tilt it to 0°, and open the motor cover.
3. Loosen the four motor mounting hex nuts (**Figure 147**) two turns, and place the 2x6 block between the cabinet and bottom of the motor, as shown in **Figure 150**.



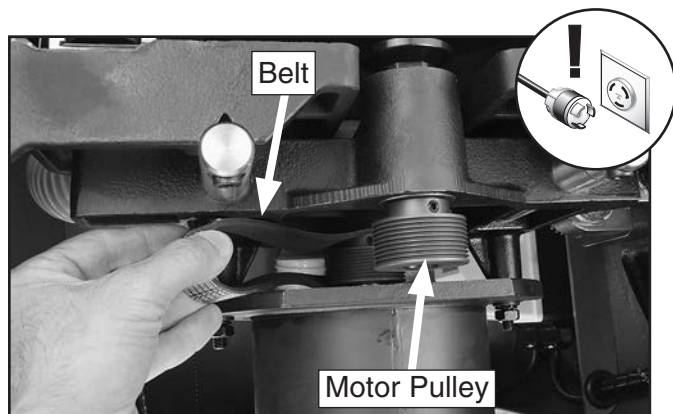
**Figure 150.** Motor resting on wood block.

4. Lower the arbor assembly until the motor rests on the wood block, as shown in **Figure 150**, then turn the handwheel an additional turn in the same direction to reduce tension on the belt.

**Note:** *Be careful not to lower the motor too far or the board may damage the capacitor covers. Also, do not force the arbor down farther when it becomes difficult to move the handwheel.*

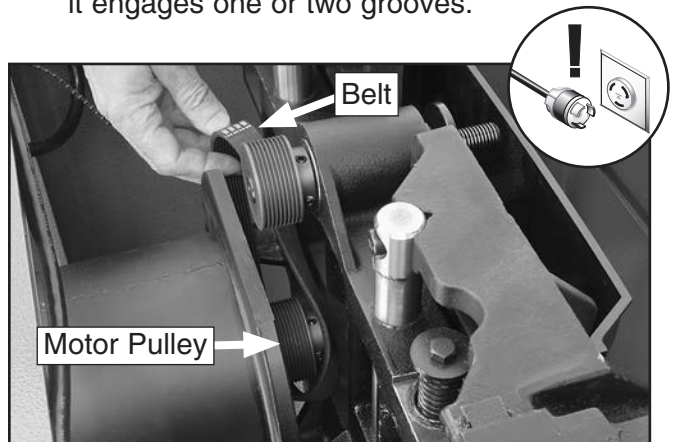
5. Tighten the motor mounting nuts to hold the motor in place.
6. Raise the motor all the way up and remove the wood block.
7. Roll the belt off of the upper and lower pulleys, as shown in **Figure 151**. Be careful not to pinch your fingers.

**Note:** *To make belt removal easier, turn the belt sideways and slide it down and past the back of the motor pulley.*



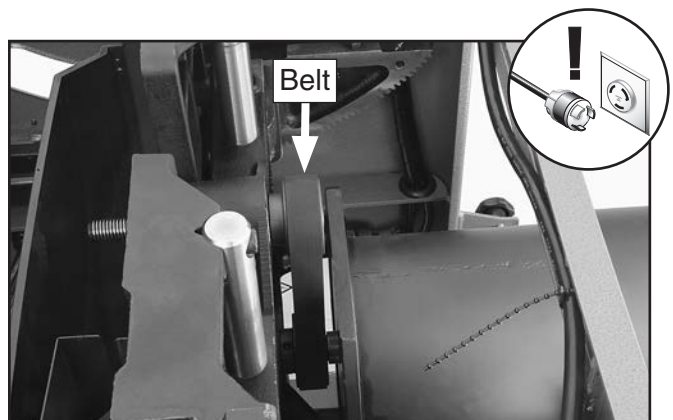
**Figure 151.** Removing belt (table removed for clarity).

8. Turn the new belt sideways and slip it over the motor pulley, as shown in **Figure 152**, so it engages one or two grooves.



**Figure 152.** Installing belt.

9. Push the belt inward and roll it onto the top pulley. Continue pushing the belt and rotating it up and down until it is centered on both pulleys, as shown in **Figure 153**.



**Figure 153.** Belt installed.

10. Follow **Steps 2-7** in "Tensioning Belt" to tension the belt.



# SECTION 9: WIRING

These pages are current at the time of printing. However, in the spirit of improvement, we may make changes to the electrical systems of future machines. Compare the manufacture date of your machine to the one stated in this manual, and study this section carefully.

If there are differences between your machine and what is shown in this section, call Technical Support at (570) 546-9663 for assistance BEFORE making any changes to the wiring on your machine. An updated wiring diagram may be available. **Note:** *Please gather the serial number and manufacture date of your machine before calling. This information can be found on the main machine label.*

## WARNING

### Wiring Safety Instructions

**SHOCK HAZARD.** Working on wiring that is connected to a power source is extremely dangerous. Touching electrified parts will result in personal injury including but not limited to severe burns, electrocution, or death. Disconnect the power from the machine before servicing electrical components!

**MODIFICATIONS.** Modifying the wiring beyond what is shown in the diagram may lead to unpredictable results, including serious injury or fire. This includes the installation of unapproved after-market parts.

**WIRE CONNECTIONS.** All connections must be tight to prevent wires from loosening during machine operation. Double-check all wires disconnected or connected during any wiring task to ensure tight connections.

**CIRCUIT REQUIREMENTS.** You MUST follow the requirements at the beginning of this manual when connecting your machine to a power source.

**WIRE/COMPONENT DAMAGE.** Damaged wires or components increase the risk of serious personal injury, fire, or machine damage. If you notice that any wires or components are damaged while performing a wiring task, replace those wires or components.

**MOTOR WIRING.** The motor wiring shown in these diagrams is current at the time of printing but may not match your machine. If you find this to be the case, use the wiring diagram inside the motor junction box.
















**CAPACITORS/INVERTERS.** Some capacitors and power inverters store an electrical charge for up to 10 minutes after being disconnected from the power source. To reduce the risk of being shocked, wait at least this long before working on capacitors.

**EXPERIENCING DIFFICULTIES.** If you are experiencing difficulties understanding the information included in this section, contact our Technical Support at (570) 546-9663.

#### NOTICE

The photos and diagrams included in this section are best viewed in color. You can view these pages in color at [www.grizzly.com](http://www.grizzly.com).

#### COLOR KEY

BLACK 	BLUE 	YELLOW 	LIGHT BLUE 
WHITE 	BROWN 	YELLOW GREEN 	BLUE WHITE 
GREEN 	GRAY 	PURPLE 	TURQUOISE 
RED 	ORANGE 	PINK 	



# Common Electrical Components



Figure 154. G0605X1/G0696X motor junction box.

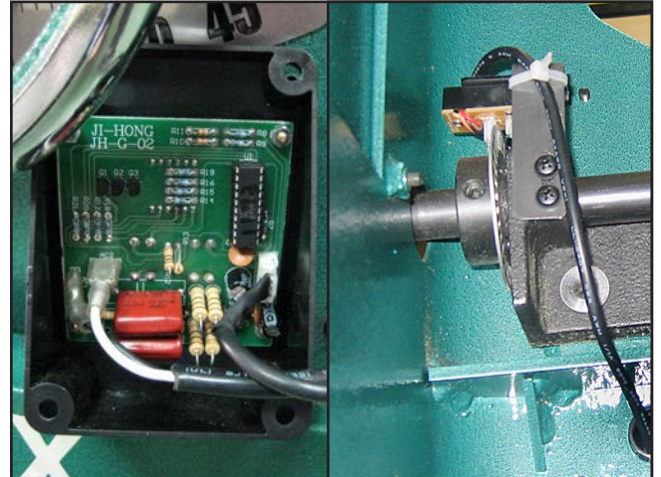


Figure 157. Digital readout and angle sensor.



Figure 155. On/Off switch.



Figure 156. G0606X1/G0697X motor junction box.

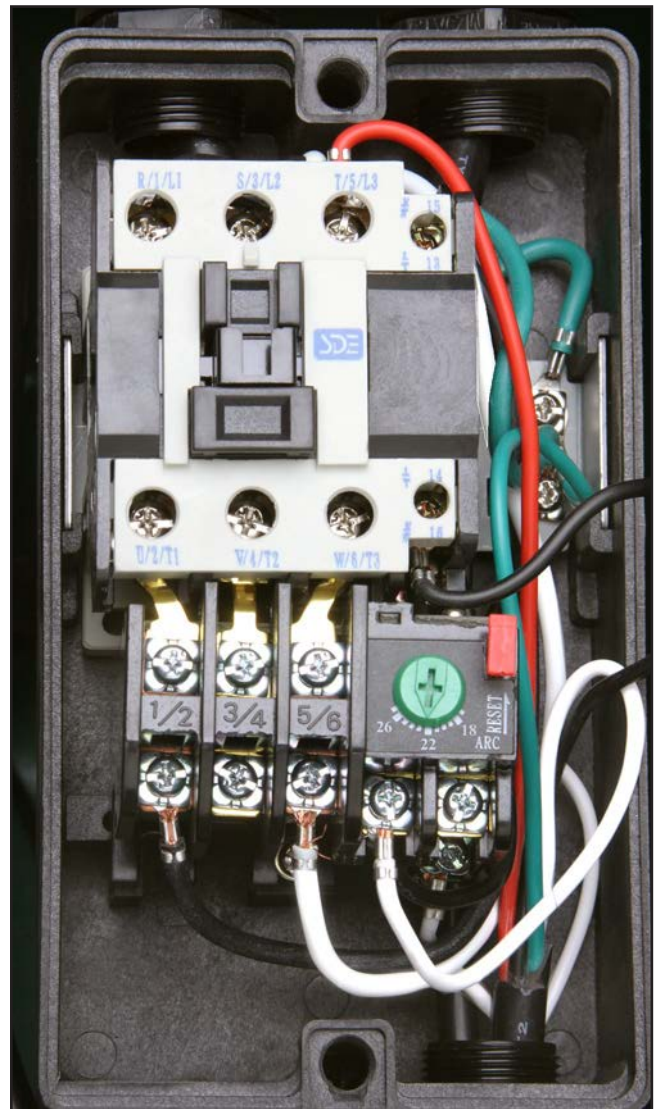
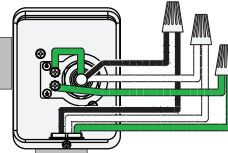


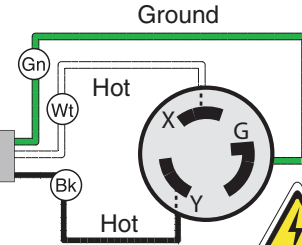
Figure 158. G0605X1/G0696X magnetic switch.

# G0605X1/G0696X Wiring 220V, 1-Ph

## Power Junction Box



## L6-30 Plug (As Recommended)



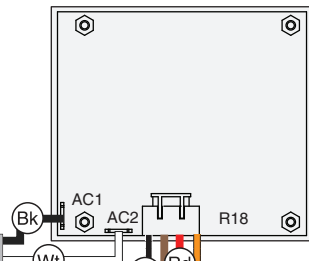
220 VAC

## Magnetic Switch Assembly MPE-30

See Figure 158, Page 78

## Digital Readout

See Figure 157, Page 78

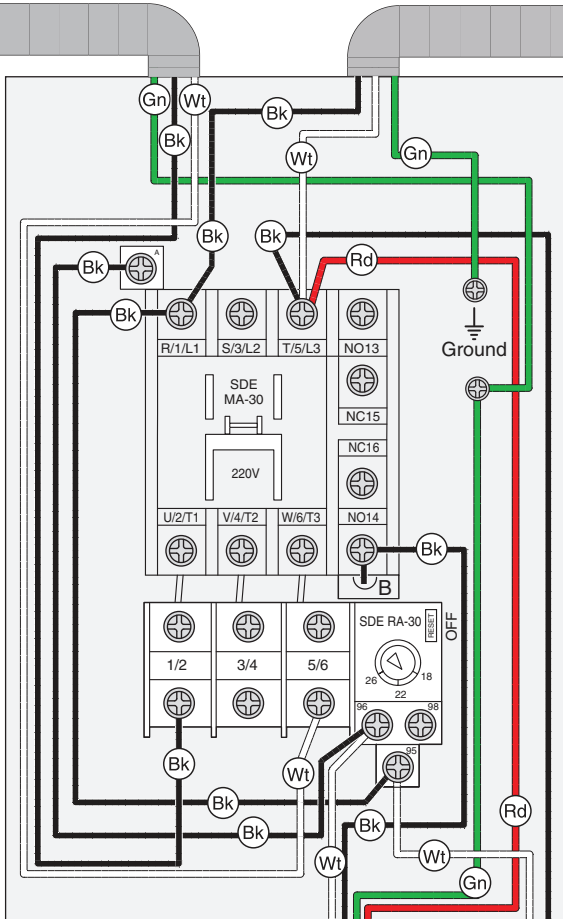
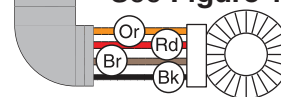


### NOTICE

Installation work and electrical wiring must be done by qualified electrician in accordance with all applicable codes and standards.

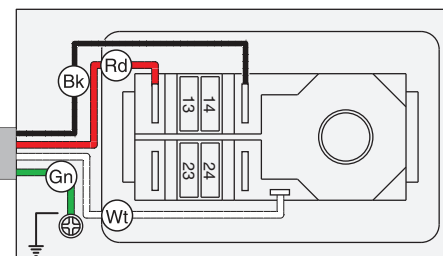
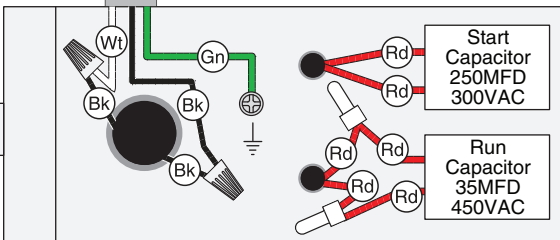
## Angle Sensor

See Figure 157, Page 78



## 220V Motor

See Figure 154, Page 78



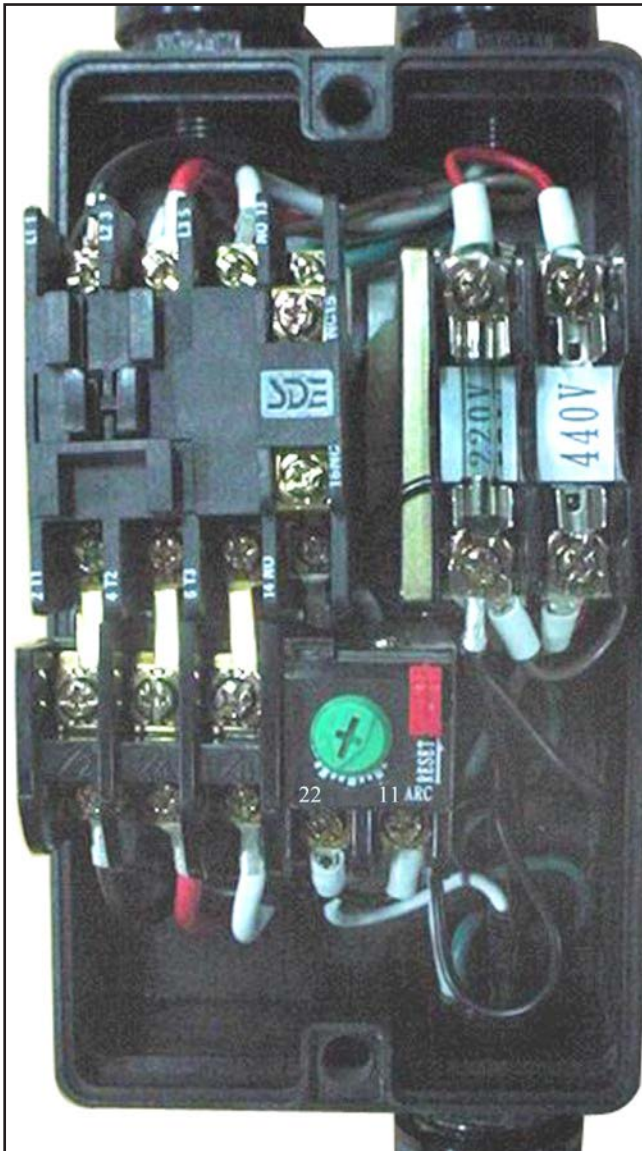
OFF ON

## On/Off Switch

See Figure 155, Page 78

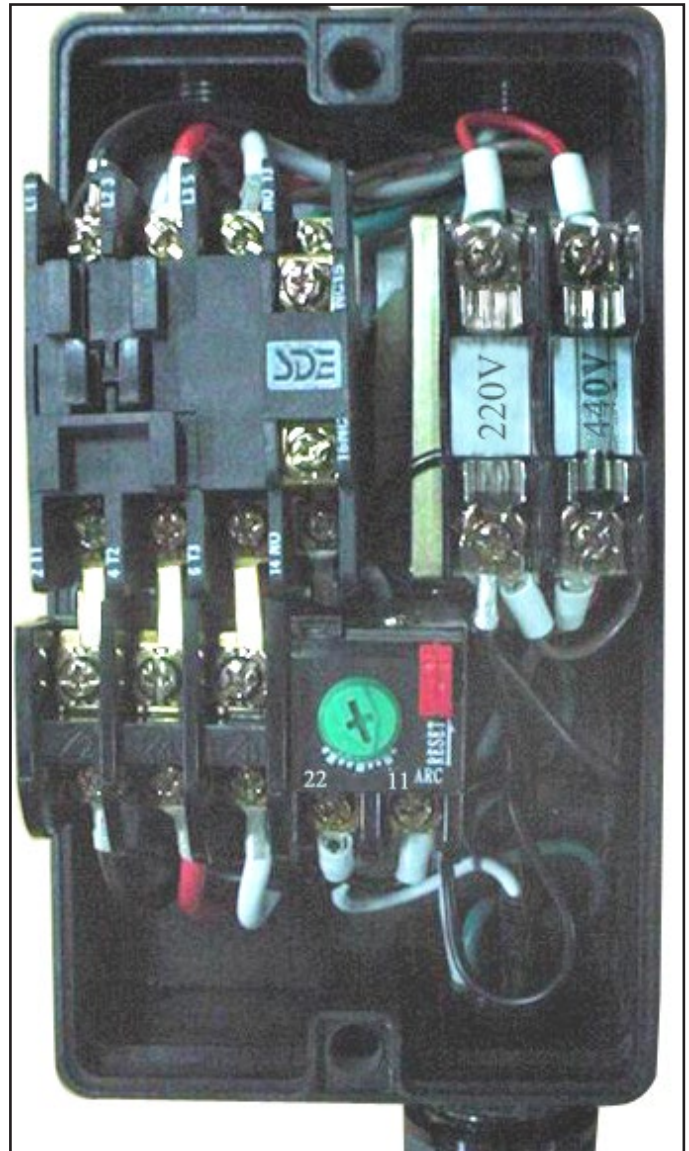


# G0606X1/G0697X Electrical Components



**Figure 159.** G0606X1/G0697X magnetic switch prewired to 220V, 3-phase.

**Note:** The thermal relay in **Figure 159** is set for 20 amp, 220V, 3-phase operation.



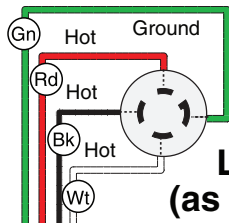
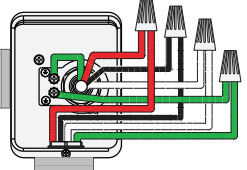
**Figure 160.** G0606X1/G0697X magnetic switch converted to 440V, 3-phase.

**Note:** The thermal relay in **Figure 160** is adjusted for 10 amp, 440V, 3-phase operation.

# G0606X1/G0697X Wiring 220V, 3-Ph

**MOTOR DIRECTION NOTICE**  
 If motor rotates in opposite direction, swap any two power source wires at the incoming terminals.

## Power Junction Box

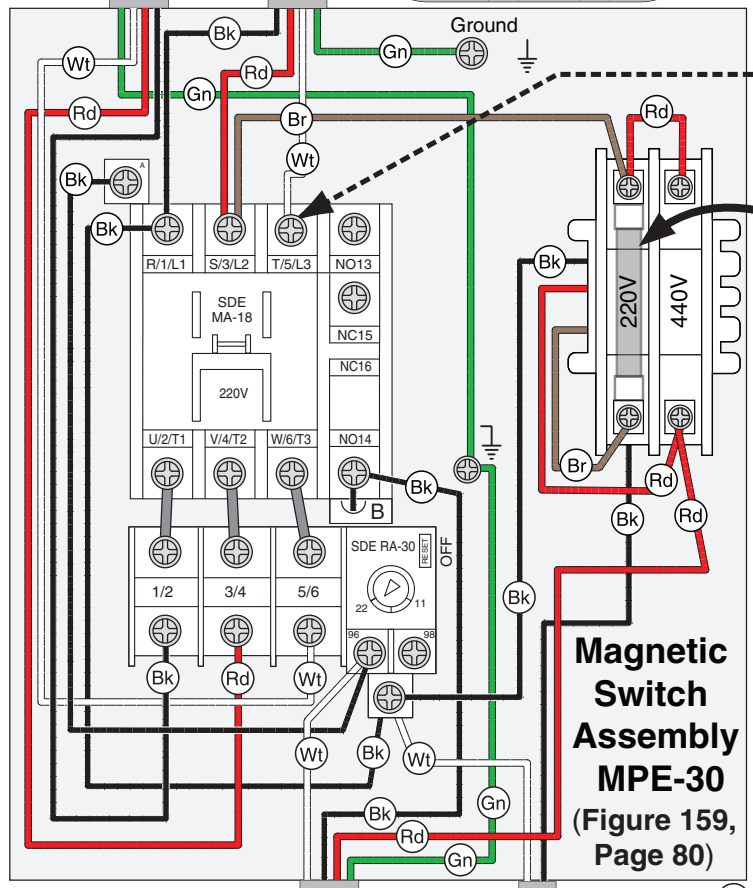


**220 VAC L15-30 PLUG**  
 (as recommended)

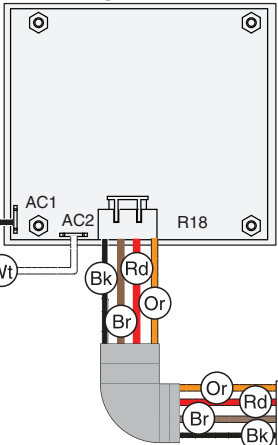
**PHASE CONVERTER NOTICE**  
 If connecting machine to a phase converter, the manufactured leg must be connected to terminal L3.



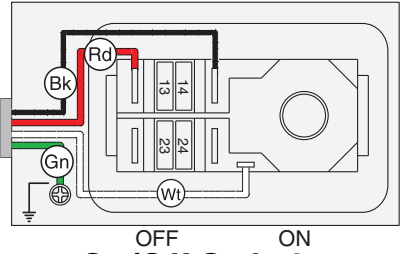
**NOTICE**  
 Installation work and electrical wiring must be done by qualified electrician in accordance with all applicable codes and standards.



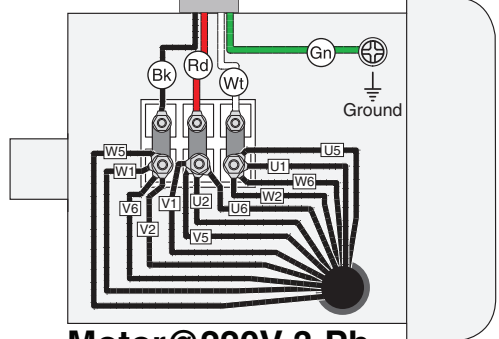
**Digital Readout**  
 See Figure 157, Page 78



**Angle Sensor**  
 See Figure 157, Page 78



**On/Off Switch**  
 See Figure 155, Page 78



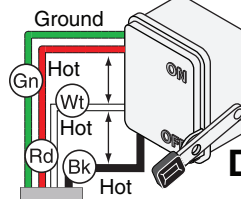
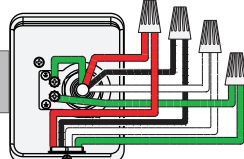
**Motor @ 220V 3-Ph**  
 See Figure 156, Page 78



# G0606X1/G0697X Wiring 440V, 3-Ph

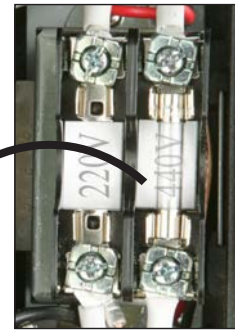
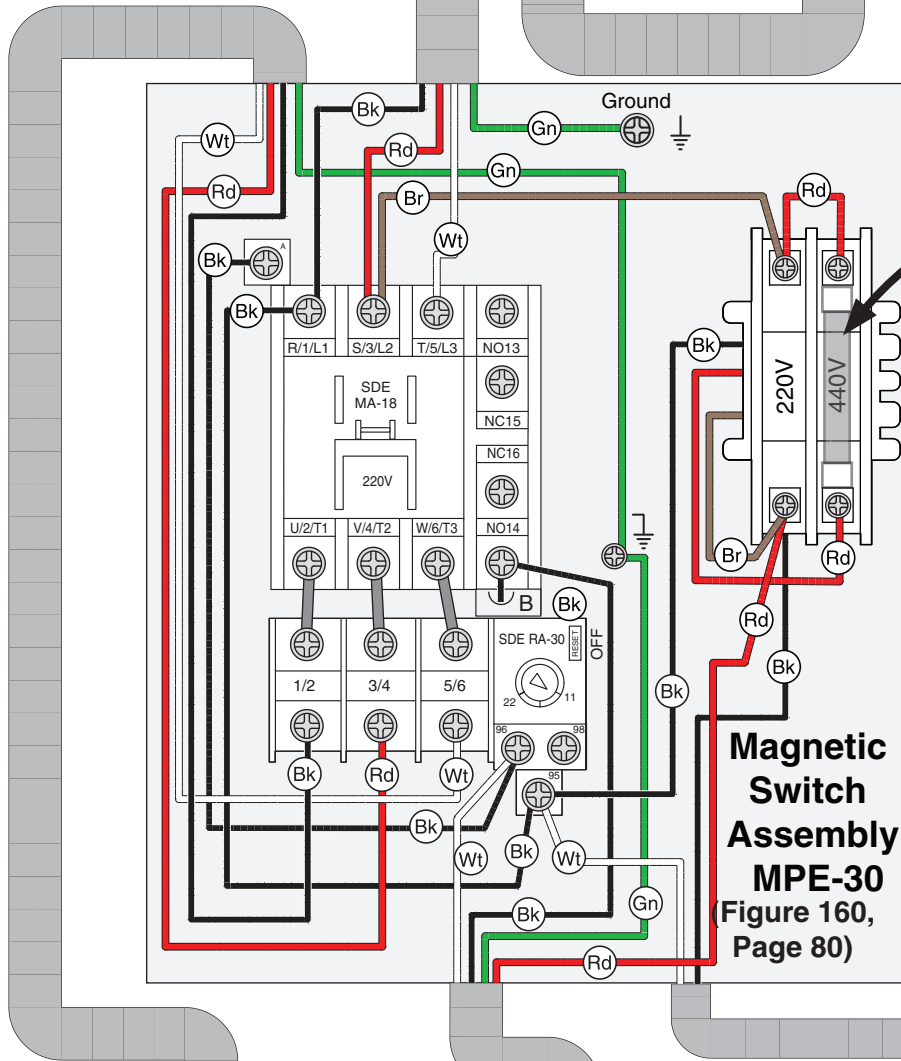
**MOTOR DIRECTION NOTICE**  
If motor rotates in opposite direction, swap any two power source wires at the incoming terminals.

## Power Junction Box



**3-PHASE  
440 VAC**

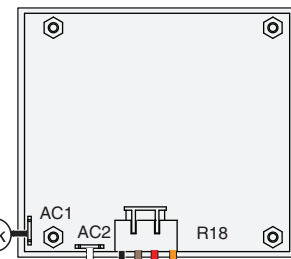
**DISCONNECT SWITCH  
(as recommended)**



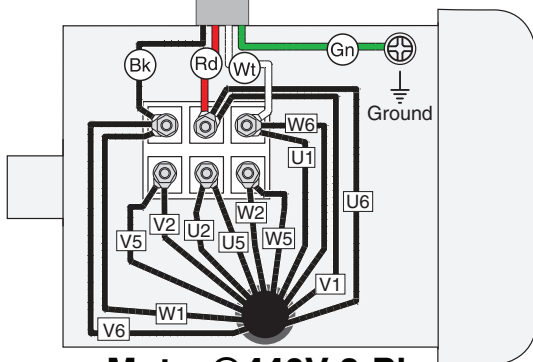
**NOTICE**  
Installation work and electrical wiring must be done by qualified electrician in accordance with all applicable codes and standards.

## Digital Readout

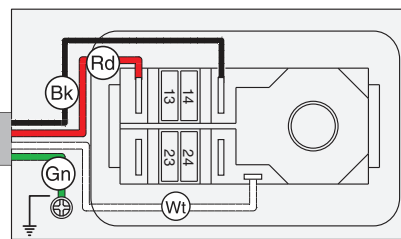
See Figure 157,  
Page 78



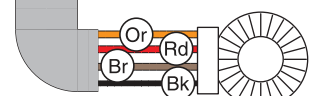
**Magnetic Switch Assembly MPE-30**  
(Figure 160, Page 80)



**Motor@440V 3-Ph**  
See Figure 156, Page 78



**On/Off Switch**  
See Figure 155, Page 78

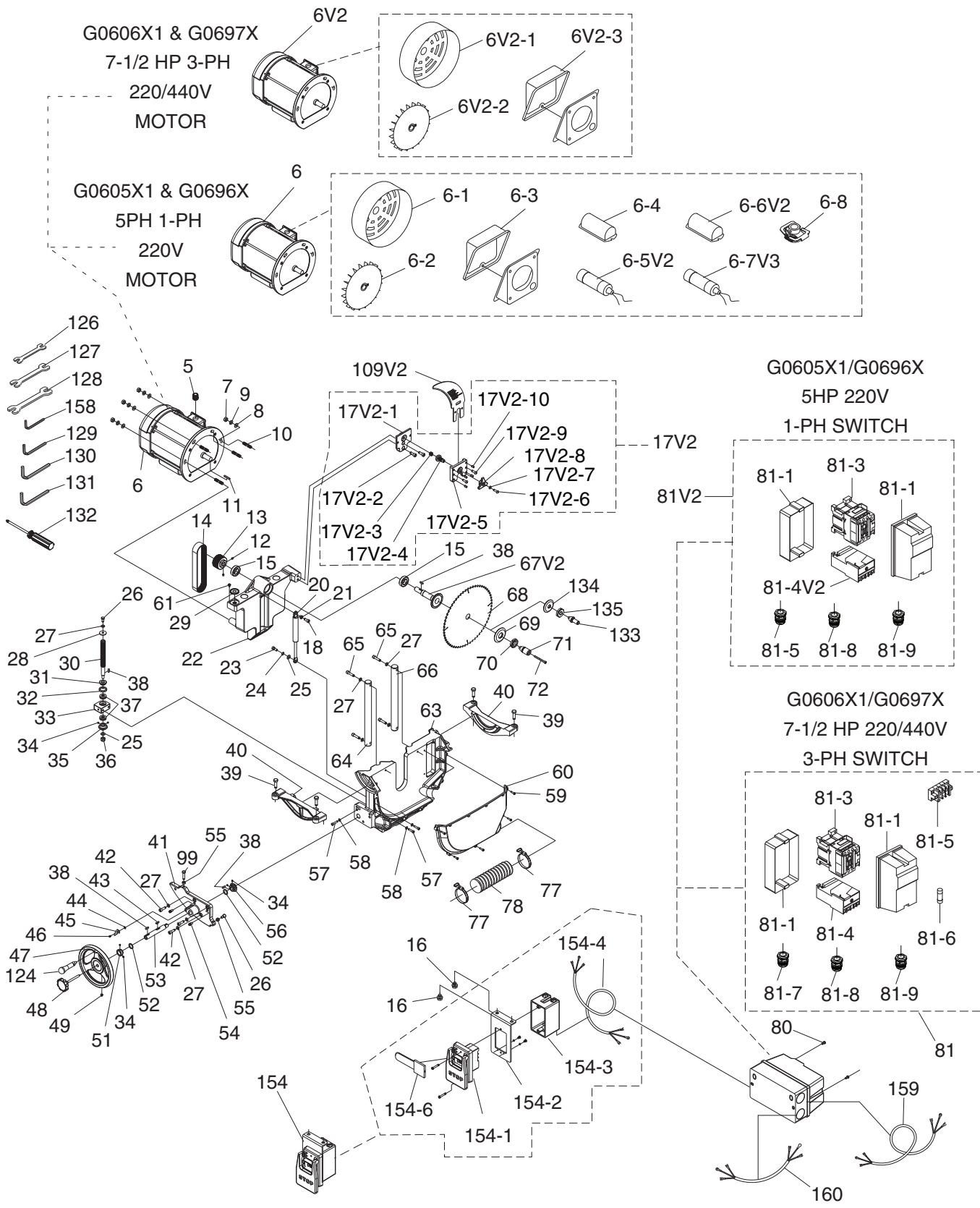


**Angle Sensor**  
See Figure 157,  
Page 78



# SECTION 10: PARTS

## Motor and Arbor



# Motor and Arbor Parts List

REF	PART #	DESCRIPTION
5	P0605X1005	STRAIN RELIEF
7	PN02M	HEX NUT M10-1.5
8	PW04M	FLAT WASHER 10MM
9	PLW06M	LOCK WASHER 10MM
10	P0605X1010	MOTOR BOLT
11	PK02M	KEY 5 X 5 X 40
12	PSS03M	SET SCREW M6-1 X 8
13	P0605X1013	MOTOR PULLEY
14	P0605X1014	FLAT BELT 220-J12
15	P6005-2RS	BALL BEARING 6005 2RS
16	PFB15M	FLANGE BOLT M8-1.25 X 12
17V2	P0605X1017V2	MOUNTING BRACKET V2.01.10
17V2-1	P0605X1017V2-1	MOUNTING BRACKET BASE V2.01.10
17V2-2	PCAP14M	CAP SCREW M8-1.25 X 20
17V2-3	P0661044V2-3	COMPRESSION SPRING V2.01.10
17V2-4	P0661044V2-4	LOCKING BOLT V2.01.10
17V2-5	P0605X1017V2-5	MOUNTING BRACKET PLATE V2.01.10
17V2-6	PBHS06M	BUTTON HD CAP SCR M5-.8 X 12
17V2-7	PLW01M	LOCK WASHER 5MM
17V2-8	P0661044V2-8	HANDLE V2.01.10
17V2-9	PBHS16M	BUTTON HD CAP SCR M5-.8 X 16
17V2-10	PSS47M	SET SCREW M3-.5 X 10
18	PCAP14M	CAP SCREW M8-1.25 X 20
20	P0605X1020	STRUT
21	P0605X1021	BUSHING
22	P0605X1022	BRACKET
23	P0605X1023	STRUT SCREW
24	P0605X1024	WAVE WASHER 10MM
25	PW04M	FLAT WASHER 10MM
26	PB09M	HEX BOLT M8-1.25 X 20
27	PLW04M	LOCK WASHER 8MM
28	PW01M	FLAT WASHER 8MM
29	P0605X1029	BRUSH
30	P0605X1030	LEADSCREW
31	P0605X1031	BUSHING
32	P0605X1032	GASKET
33	P0605X1033	LEADSCREW BRACKET
34	PSS07M	SET SCREW M5-.8 X 5
35	P0605X1035	LEFT BEVEL GEAR
36	PLN10M	LOCK NUT M10-1.25
37	P51102	THRUST BEARING 51102
38	PK14M	KEY 5 X 5 X 18
39	PB14M	HEX BOLT M10-1.5 X 35
40	P0605X1040	TRUNNION SLIDE
41	P0605X1041	PLATE
42	PCAP31M	CAP SCREW M8-1.25 X 25
43	P0605X1043	WOODRUFF KEY 22 X 5
44	PTLW05M	EXT TOOTH WASHER 6MM
45	P0605X021	TILT ARROW POINTER
46	PS14M	PHLP HD SCR M6-1 X 12
47	P0605X1047	HANDWHEEL

REF	PART #	DESCRIPTION
48	P0605X1048	HANDWHEEL LOCK KNOB
49	PSS17	SET SCREW 5/16-18 X 5/16
51	P0605X1051	LOCK COLLAR
52	PW18M	FLAT WASHER 18MM
53	P0605X1053	BLADE HEIGHT HANDWHEEL SHAFT
54	P0605X1054	ALIGNMENT PIN
55	PN03M	HEX NUT M8-1.25
56	P0605X1056	RIGHT BEVEL GEAR
57	PCAP06M	CAP SCREW M6-1 X 25
58	PLW03M	LOCK WASHER 6MM
59	PS06M	PHLP HD SCR M5-.8 X 20
60	P0605X1060	BLADE COVER
61	PS09M	PHLP HD SCR M5-.8 X 10
63	P0605X1063	TRUNNION
64	P0605X1064	FRONT COLUMN
65	PCAP12M	CAP SCREW M8-1.25 X 40
66	P0605X1066	REAR COLUMN
67V2	P0605X1067V2	ARBOR SHAFT 1" V2.01.10
68	P0605X1068	BLADE
69	P0605X1069	ARBOR FLANGE
70	P0605X1070	ARBOR NUT 1"-10
71	P0605X1071	ARBOR EXTENSION 1"-10
72	PCAP189M	CAP SCREW M6-1 X 60 BLK C12.9 USA
77	P0605X1077	HOSE CLAMP 60-80MM
78	P0605X1078	DUST CHUTE HOSE 63 X 1000MM
80	PS01	PHLP HD SCR 10-24 X 1/2
99	PB20M	HEX BOLT M8-1.25 X 35
109V2	P0605X1109V2	RIVING KNIFE V2.01.10
124	P0605X1124	HANDWHEEL HANDLE
126	PWR810	WRENCH 8 X 10MM OPEN-END
127	PWR1113	WRENCH 11 X 13MM OPEN-END
128	PWR1417	WRENCH 14 X 17MM OPEN-END
129	PAW04M	HEX WRENCH 4MM
130	PAW05M	HEX WRENCH 5MM
131	PAW06M	HEX WRENCH 6MM
132	P0605X1132	PHILLIPS/STANDARD SCREWDRIVER
133	P0605X1133	ARBOR EXTENSION 5/8"-12 x 1-1/4"
134	P0605X1134	ARBOR FLANGE 5/8"
135	P0605X1135	ARBOR NUT 5/8"-12
154	P0605X1154	ON/OFF SWITCH ASSY 5HP-1HP
154-1	P0605X1154-1	ON/OFF PUSH BUTTON SWITCH
154-2	P0605X1154-2	ON/OFF SWITCH BRACKET
154-3	P0605X1154-3	ON/OFF SWITCH BOX
154-4	P0605X154-4	ON/OFF SWITCH CORD 16AWG X 4C
154-6	T23243	SWITCH PADLOCK W/KEY
158	PAW03M	HEX WRENCH 3MM
159	P0605X1159	MOTOR CORD 12G 3C (G0605X1/96X)
159	P0606X1159	MOTOR CORD 12G 4C ST 600V (G0606X1/97X)
160	P0605X1160	POWER CORD 12G 3C 600V (G0605X1/96X)
160	P0606X1160	POWER CORD 12G 4C ST 600V (G0606X1/97X)
161	P0605X1161	GROUND WIRE 12G 1C 150MM



## G0605X1/G0696X 5HP, 1-PH MOTOR

REF	PART #	DESCRIPTION
6	P0605X1006	MOTOR 5HP 220V 1-PH
6-1	P0605X1006-1	MOTOR FAN COVER
6-2	P0605X1006-2	MOTOR FAN
6-3	P0605X1006-3	WIRING JUNCTION BOX
6-4V2	P0605X1006-4V2	R CAPACITOR COVER V2.08.11
6-5V2	P0605X1006-5V2	R CAPACITOR 35M 450V V2.08.11
6-6V2	P0605X1006-6V2	S CAPACITOR COVER V2.05.12
6-7V3	P0605X1006-7V3	S CAPACITOR 250M 300V 1-3/4 X 3-1/2 V3.05.12
6-8	P0605X1006-8	CENTRIFUGAL SWITCH

## G0605X1/G0696X 5HP, 1-PH MAG SWITCH

REF	PART #	DESCRIPTION
81V2	P0605X1081V2	MAG SWITCH SDE MP-30 V2.08.11
81-1	P0605X1081-1	MAG SWITCH FRONT/BACK COVER
81-3	P0605X1081-3	CONTACTOR SDE MA-30 220V
81-4V2	P0605X1081-4V2	OL RELAY SDE RA-30 18-26A V2.08.11
81-5	P0605X1081-5	STRAIN RELIEF MG20A-10-STB-XA
81-8	P0605X1081-8	STRAIN RELIEF MG20AS-10B-XA
81-9	P0605X1081-9	STRAIN RELIEF MG20AS-06B-XA

## G0606X1/G0697X 7½HP, 3-PH MOTOR

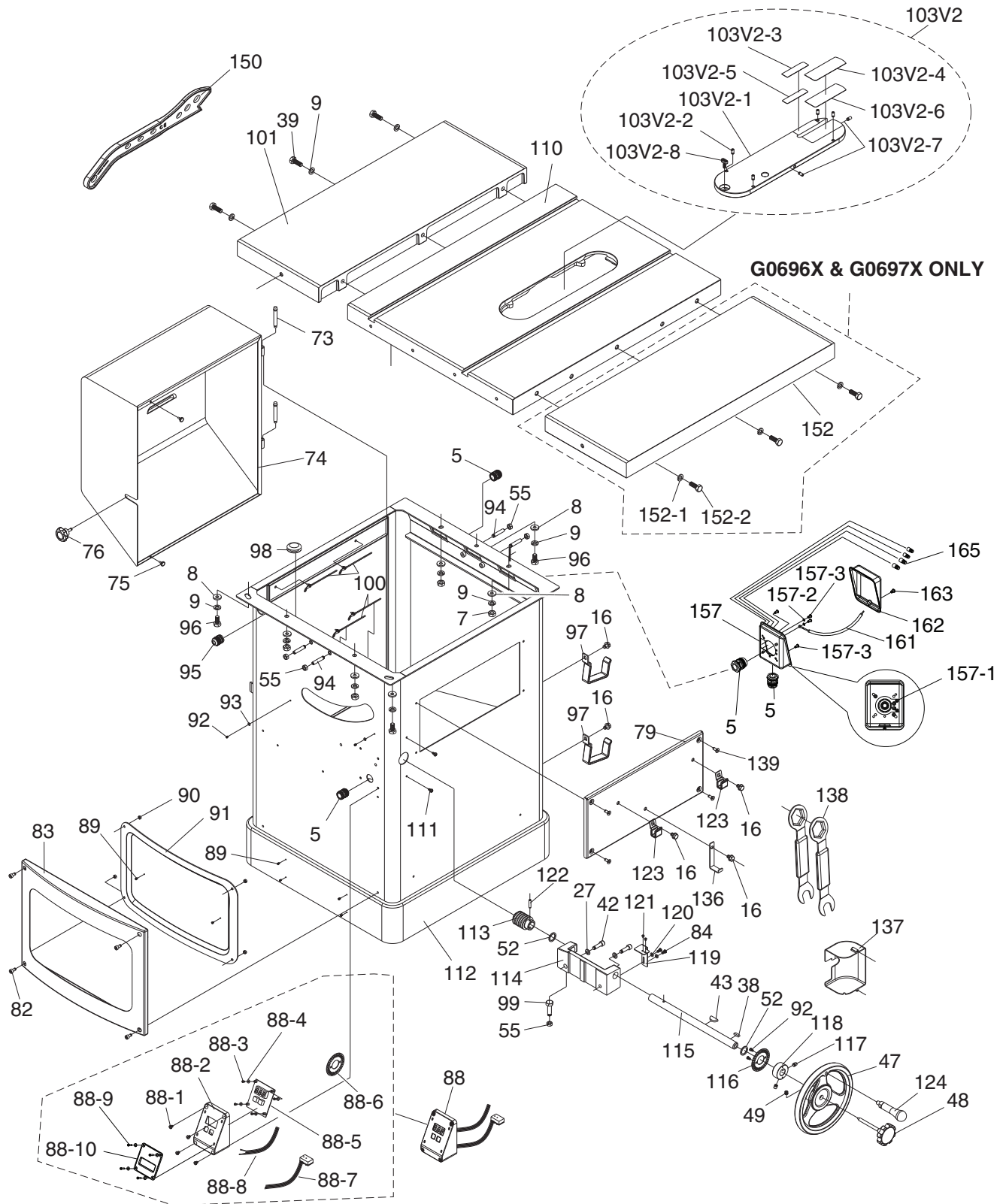
REF	PART #	DESCRIPTION
6V2	P0606X1006	MOTOR 7-1/2 HP 220V/440V 3-PH V2.11.11
6V2-1	P0606X1006-1	MOTOR FAN COVER
6V2-2	P0606X1006-2	MOTOR FAN
6V2-3	P0606X1006-3	WIRING JUNCTION BOX

## G0606X1/G0697X 7½HP, 3-PH MAG SWITCH

REF	PART #	DESCRIPTION
81	P0606X1081	MAGNETIC SWITCH ASSY MPE-30
81-1	P0606X1081-1	MAG SWITCH FRONT/BACK COVER
81-3	P0606X1081-3	CONTACTOR SDE MA-18 220V
81-4	P0606X1081-4	OL RELAY SDE RA-30 11-22A
81-5	P0606X1081-5	TRANSFORMER
81-6	P0606X1081-6	FUSE
81-7	P0606X1081-7	STRAIN RELIEF
81-8	P0606X1081-8	STRAIN RELIEF
81-9	P0606X1081-9	STRAIN RELIEF



# Cabinet



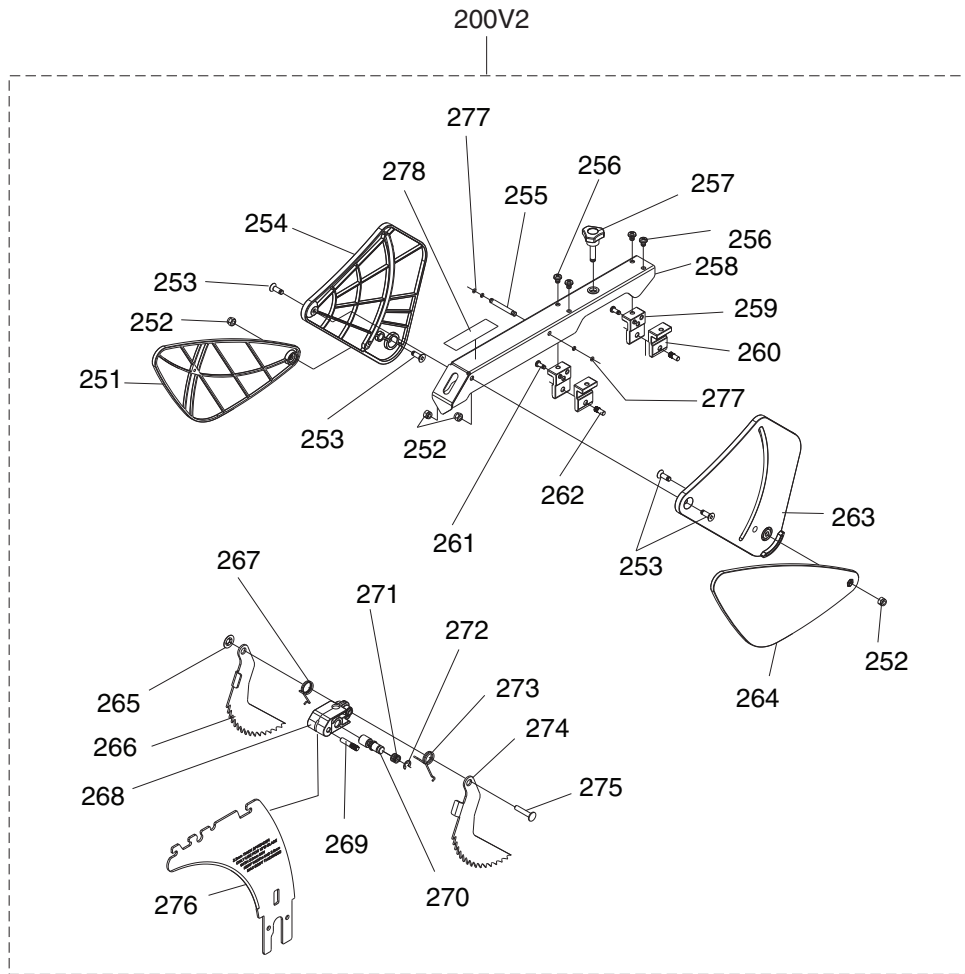
# Cabinet Parts List

REF	PART #	DESCRIPTION
5	P0605X1005	STRAIN RELIEF
7	PN02M	HEX NUT M10-1.5
8	PW04M	FLAT WASHER 10MM
9	PLW06M	LOCK WASHER 10MM
16	PFB15M	FLANGE BOLT M8-1.25 X 12
27	PLW04M	LOCK WASHER 8MM
38	PK14M	KEY 5 X 5 X 18
39	PB14M	HEX BOLT M10-1.5 X 35
42	PCAP31M	CAP SCREW M8-1.25 X 25
43	P0605X1043	WOODRUFF KEY 22 X 5
47	P0605X1047	HANDWHEEL
48	P0605X1048	HANDWHEEL LOCK KNOB
49	PSS17	SET SCREW 5/16-18 X 5/16
52	PW18M	FLAT WASHER 18MM
55	PN03M	HEX NUT M8-1.25
73	P0605X1073	ALIGNMENT PIN
74	P0605X1074	MOTOR COVER
75	P0605X1075	RUBBER BUMPER
76	P0605X1076	LOCK KNOB M6-1 X 17
79	P0605X1079	RIGHT COVER
82	PCAP26M	CAP SCREW M6-1 X 12
83	P0605X1083	COVER
84	PS05M	PHLP HD SCR M5-.8 X 8
88	P0651083	DIGITAL SENSOR ASSEMBLY
88-1	PS05M	PHLP HD SCR M5-.8 X 8
88-2	P0651083-2	DIGITAL READOUT COVER
88-3	PS79M	PHLP HD SCR M3-.5 X 8
88-4	PW07M	FLAT WASHER 3MM
88-5	P0651083-5	CIRCUIT BOARD
88-6	P0651083-6	SENSOR PLATE
88-7	P0651083-7	DATA CORD 24 AWG X 450
88-8	P0651083-8	DIGITAL RDT CORD 18 AWG X 2C
88-9	PS50M	PHLP HD SCR M3-.5 X 12
88-10	P0605X1088-10	DIGITAL SENSOR COVER
89	PS79M	PHLP HD SCR M3-.5 X 8
90	PN06M	HEX NUT M5-.8
91	P0605X1091	PLATE
92	PS17M	PHLP HD SCR M4-.7 X 6
93	PW05M	FLAT WASHER 4MM
94	PSS42M	SET SCREW M8-1.25 X 50
95	P0605X1095	STRAIN RELIEF PGA13.5-11B
96	PB32M	HEX BOLT M10-1.5 X 25
97	P0651097	FENCE MOUNTING BRACKET
98	P0605X1098	STRAIN RELIEF

REF	PART #	DESCRIPTION
99	PB20M	HEX BOLT M8-1.25 X 35
100	P0605X1100	CHAIN
101	P0605X1101	LEFT EXTENSION WING
103V2	P0605X1103V2	TABLE INSERT ASSY V2.01.10
103V2-1	P0605X1103V2-1	PLATE V2.01.10
103V2-2	P0605X1103V2-2	BOLT V2.01.10
103V2-3	P0605X1103V2-3	LEFT PLATE V2.01.10
103V2-4	P0605X1103V2-4	RIGHT PLATE V2.01.10
103V2-5	P0605X1103V2-5	LEFT TAPE 19MM V2.01.10
103V2-6	P0605X1103V2-6	RIGHT TAPE 35MM V2.01.10
103V2-7	PSS04M	SET SCREW M6-1 X 12
103V2-8	P0661006V2	LOCK KNOB M5-.8 V2.01.10
110	P0605X1110	TABLE
111	PHTEK39M	TAP SCREW M4 X 12
112	P0605X1112	CABINET
113	P0605X1113	WORM GEAR
114	P0605X1114	BLADE TILT SHAFT BRACKET
115	P0605X1115	BLADE TILT SHAFT
116	P0651083-6	SENSOR PLATE
117	PSS16M	SET SCREW M8-1.25 X 10
118	P0605X1118	LOCK COLLAR
119	P0651112	L-PLATE
120	PW02M	FLAT WASHER 5MM
121	PHTEK30M	TAP SCREW M3 X 6
122	PRP27M	ROLL PIN 5 X 28
123	P0651106	MITER GAUGE MOUNTING BRKT
124	P0605X1124	HANDWHEEL HANDLE
136	P0651107	WRENCH MOUNTING BRACKET
137	P0651087	DUST COVER
138	P0651108	ARBOR WRENCH
139	PFH06M	FLAT HD SCR M6-1 X 20
150	P0661141	PUSH STICK
152	P0696X152	RIGHT EXTENSION WING
152-1	PLW06M	LOCK WASHER 10MM
152-2	PB14M	HEX BOLT M10-1.5 X 35
157	P0605X1157	JUNCTION BOX BASE
157-1	P0605X1157-1	GROUNDING LABEL
157-2	PTLW02M	EXT TOOTH WASHER 5MM
157-3	PS09M	PHLP HD SCR M5-.8 X 10
161	P0605X1161	GROUND WIRE 12G 1C 150MM
162	P0605X1162	JUNCTION BOX COVER
163	PS18	PHLP HD SCR 10-24 X 1/4
165	P0651161	WIRE NUT SW-P6H



# Blade Guard

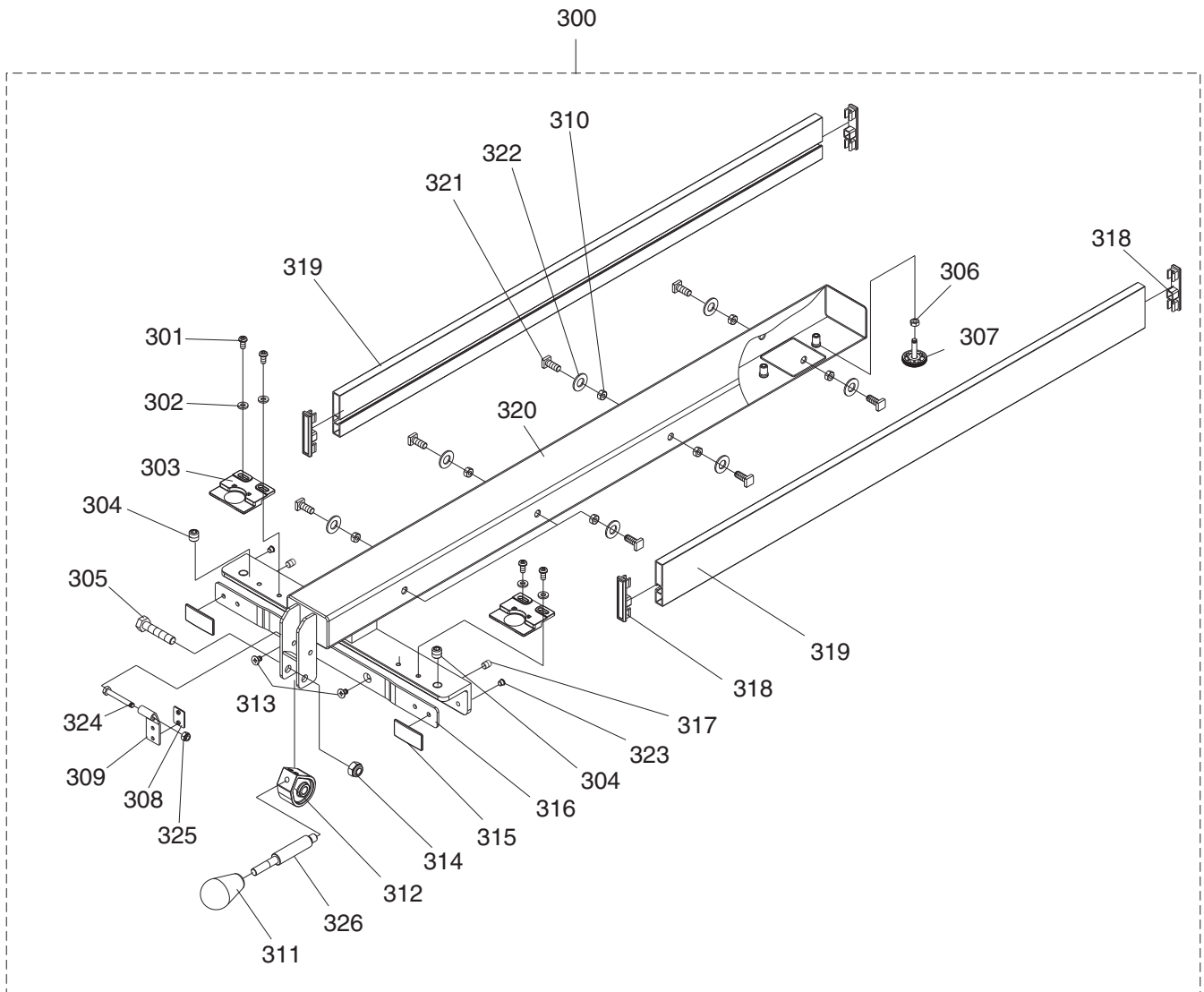


REF	PART #	DESCRIPTION
200V2	P0605X1200V2	BLADE GUARD ASSY V2.01.10
251	P0605X1200V2-1	LEFT PLATE V2.01.10
252	PLN02M	LOCK NUT M5-.8
253	PFH01M	FLAT HD SCR M5-.8 X 15
254	P0605X1200V2-4	LEFT COVER V2.01.10
255	P0661002V2-5	ROD CENTER PIN V2.01.10
256	PS19M	PHLP HD SCR M5-.8 X 6
257	P0661002V2-7	KNOB BOLT V2.01.10
258	P0605X1200V2-8	ROD V2.01.10
259	P0661002V2-9	LEFT BRACKET V2.01.10
260	P0661002V2-10	RIGHT BRACKET V2.01.10
261	PBHS24M	BUTTON HD CAP SCR M4-.7 X 10
262	P0661002V2-12	MOUNTING PIN V2.01.10
263	P0605X1200V2-13	RIGHT COVER V2.01.10
264	P0661002V2-14	RIGHT PLATE V2.01.10

REF	PART #	DESCRIPTION
265	P0661002V2-15	PUSH NUT 4MM V2.01.10
266	P0605X1200V2-16	LEFT PAWL V2.01.10
267	P0661002V2-17	RIGHT TORSION SPRING V2.01.10
268	P0661002V2-18	PAWL MOUNTING BRKT V2.01.10
269	P0661002V2-19	MOUNTING BRKT PIN V2.01.10
270	P0661002V2-20	MOUNTING BRKT SHFT V2.01.10
271	P0661002V2-21	SHAFT SPRING V2.01.10
272	PEC07M	E-CLIP 7MM
273	P0661002V2-23	LEFT TORSION SPRING V2.01.10
274	P0605X1200V2-24	RIGHT PAWL V2.01.10
275	P0661002V2-25	RIGHT PAWL SHAFT V2.01.10
276	P0605X1200V2-26	SPREADER V2.01.10
277	PORP003	O-RING 2.8 X 1.9 P3
278	P0661002V2-28	AMPUTATION HAZ LABEL V2.01.10



# Fence

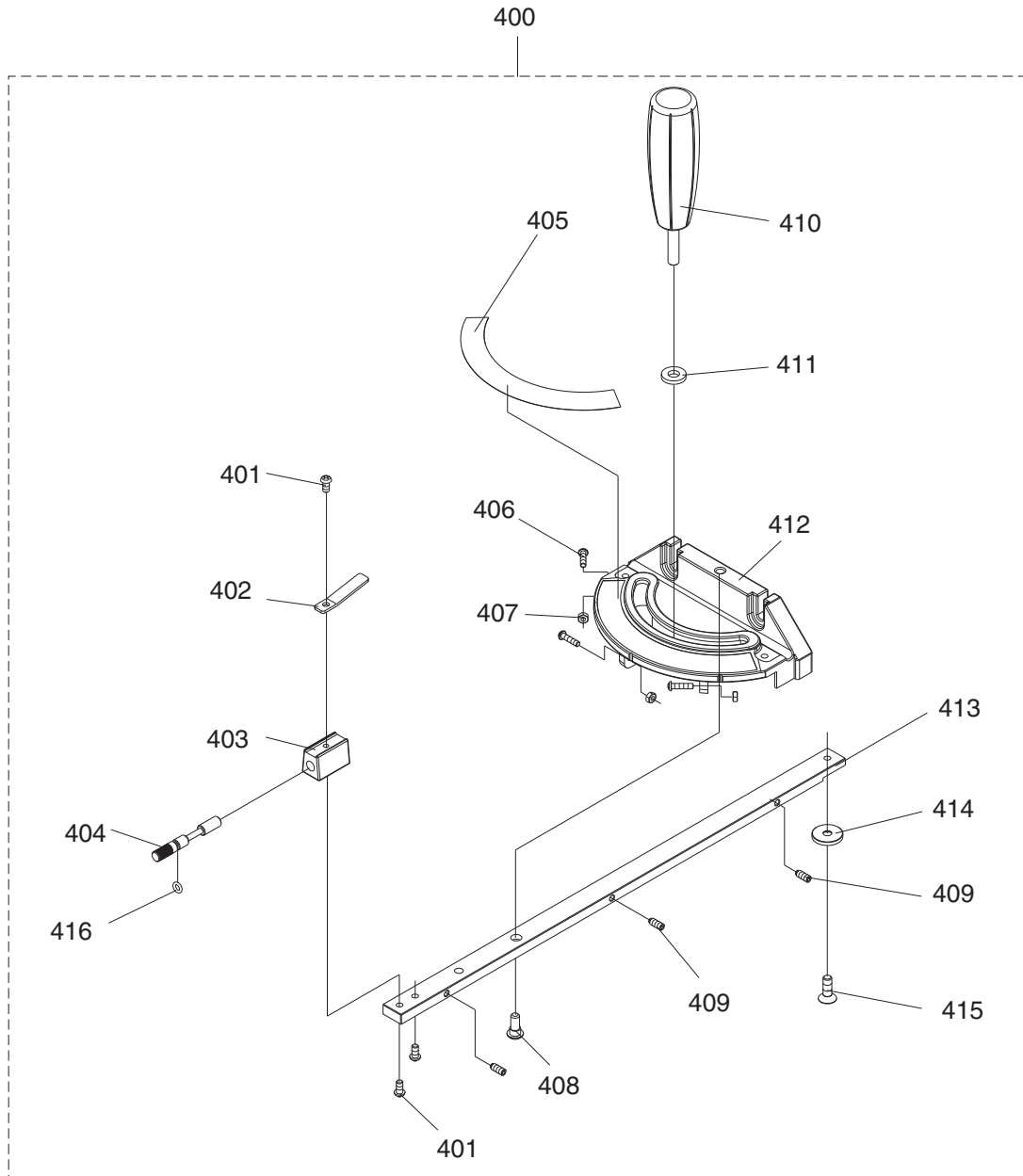


REF	PART #	DESCRIPTION
300	P0605X1300	FENCE ASSEMBLY
301	PS14M	PHLP HD SCR M6-1 X 12
302	PW03M	FLAT WASHER 6MM
303	P0605X1303	POINTER
304	P0605X1304	PLASTIC SET SCREW
305	PB73M	HEX BOLT M10-1.5 X 50
306	PN01M	HEX NUT M6-1
307	P0605X1307	REAR RAIL WHEEL
308	P0605X1308	PLATE
309	P0605X1309	BRACKET
310	PN03M	HEX NUT M8-1.25
311	P0605X1311	FENCE HANDLE
312	P0605X1312	CAM ASSEMBLY
313	PFH04M	FLAT HD SCR M6-1 X 8

REF	PART #	DESCRIPTION
314	PLN05M	LOCK NUT M10-1.5
315	P0605X1315	PLATE
316	P0605X1316	CLAMPING BRACKET
317	PSS20M	SET SCREW M8-1.25 X 8
318	P0605X1318	PLATE CAP
319	P0605X1319	FENCE PLATE
320	P0605X1320	FENCE
321	P0605X1321	T-BOLT M8-1.25 X 20
322	PW01M	FLAT WASHER 8MM
323	P0605X1323	BLOCK
324	PB71M	HEX BOLT M6-1 X 45
325	PLN03M	LOCK NUT M6-1
326	P0605X1326	SHAFT



# Miter Gauge

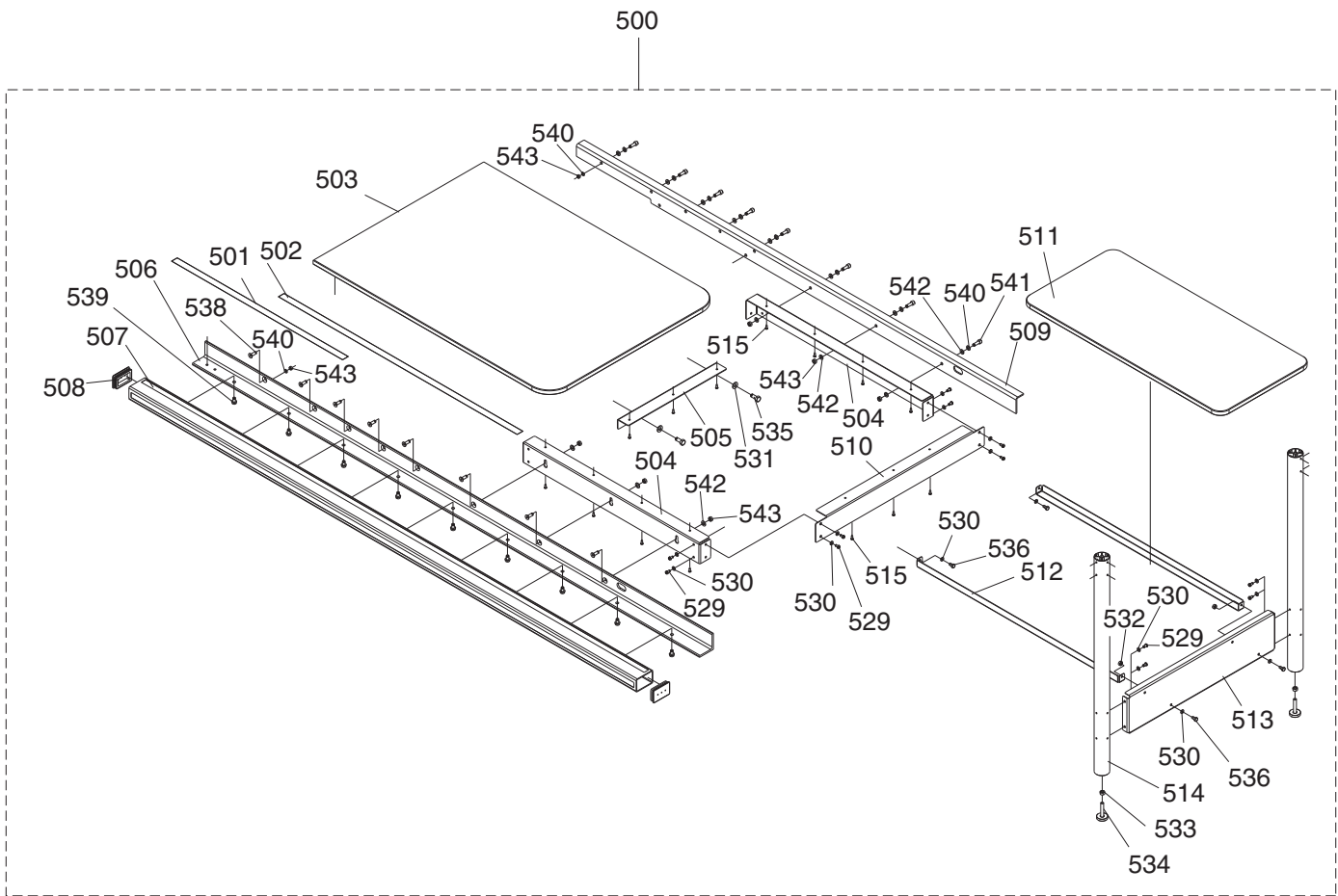


REF	PART #	DESCRIPTION
400	P0605X1400	MITER GAUGE ASSEMBLY
401	PS06	PHLP HD SCR 10-24 X 3/8
402	P0605X1402	POINTER
403	P0605X1403	BLOCK
404	P0605X1404	SHAFT
405	P0605X1405	MITER GAUGE LABEL
406	PS25	PHLP HD SCR 8-32 X 5/8
407	PN14	HEX NUT 8-32
408	P0605X1408	STEP SCREW 1/4-20 X 1/2

REF	PART #	DESCRIPTION
409	PSS53M	SET SCREW M5-.8 X 12
410	P0605X1410	MITER GAUGE HANDLE
411	PW01M	FLAT WASHER 8MM
412	P0605X1412	MITER GAUGE BODY
413	P0605X1413	PLATE
414	P0605X1414	GUIDE PLATE
415	PFH9M	FLAT HD SCR M6-1 X 6
416	PORP005	O-RING 4.8 X 1.9 P5



# Extension Table (G0605X1/G0606X1)

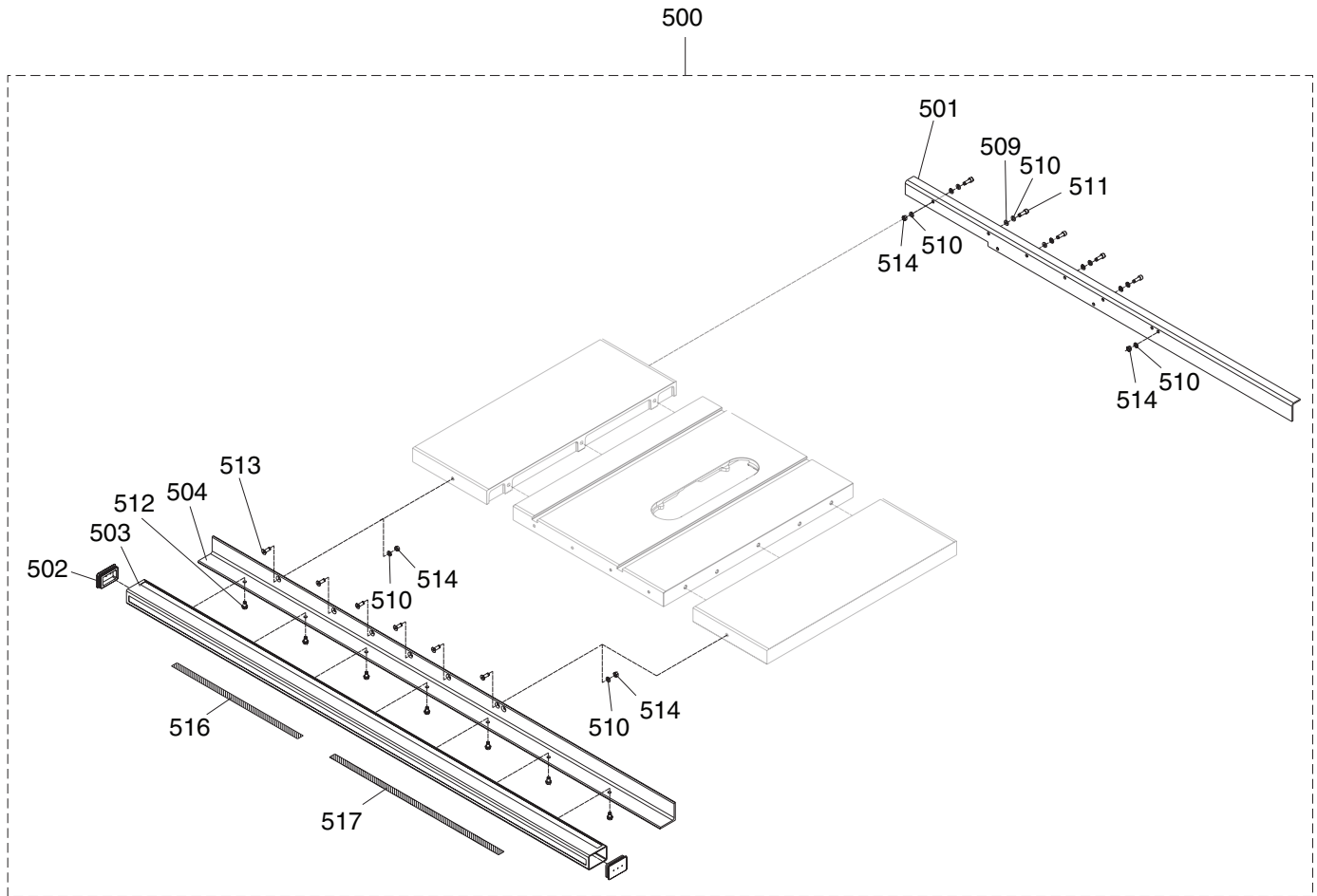


REF	PART #	DESCRIPTION
500	P0605X1500	EXTENSION TABLE ASSEMBLY
501	P0605X1501	LEFT SCALE 18"
502	P0605X1502	RIGHT SCALE 52"
503	P0605X1503	EXTENSION TABLE PLATE
504	P0605X1504	EXTENSION TABLE SUPPORT
505	P0605X1505	FRONT EXTENSION BRACKET
506	P0605X1506	FRONT RAIL
507	P0605X1507	FENCE TUBE
508	P0605X1508	END CAP
509	P0605X1509	REAR RAIL
510	P0605X1510	REAR EXTENSION BRACKET
511	P0605X1511	LOWER SHELF
512	P0605X1512	LOWER SHELF BRACKET
513	P0605X1513	SHELF END PLATE
514	P0605X1514	SUPPORT LEG

REF	PART #	DESCRIPTION
515	PHTEK6M	TAP SCREW M4 X 16
529	PS14M	PHLP HD SCR M6-1 X 12
530	PW03M	FLAT WASHER 6MM
531	PW04M	FLAT WASHER 10MM
532	PN01M	HEX NUT M6-1
533	PN08	HEX NUT 3/8"-16
534	P0605X1534	FOOT 3/8"-16 X 2
535	PB32M	HEX BOLT M10-1.5 X 25
536	PS14M	PHLP HD SCR M6-1 X 12
538	PFH21M	FLAT HD SCR M8-1.25 X 25
539	PFB15M	FLANGE BOLT M8-1.25 X 12
540	PLW04M	LOCK WASHER 8MM
541	PCAP31M	CAP SCREW M8-1.25 X 25
542	PW01M	FLAT WASHER 8MM
543	PN03M	HEX NUT M8-1.25



# Rails (Model G0696X/G0697X)

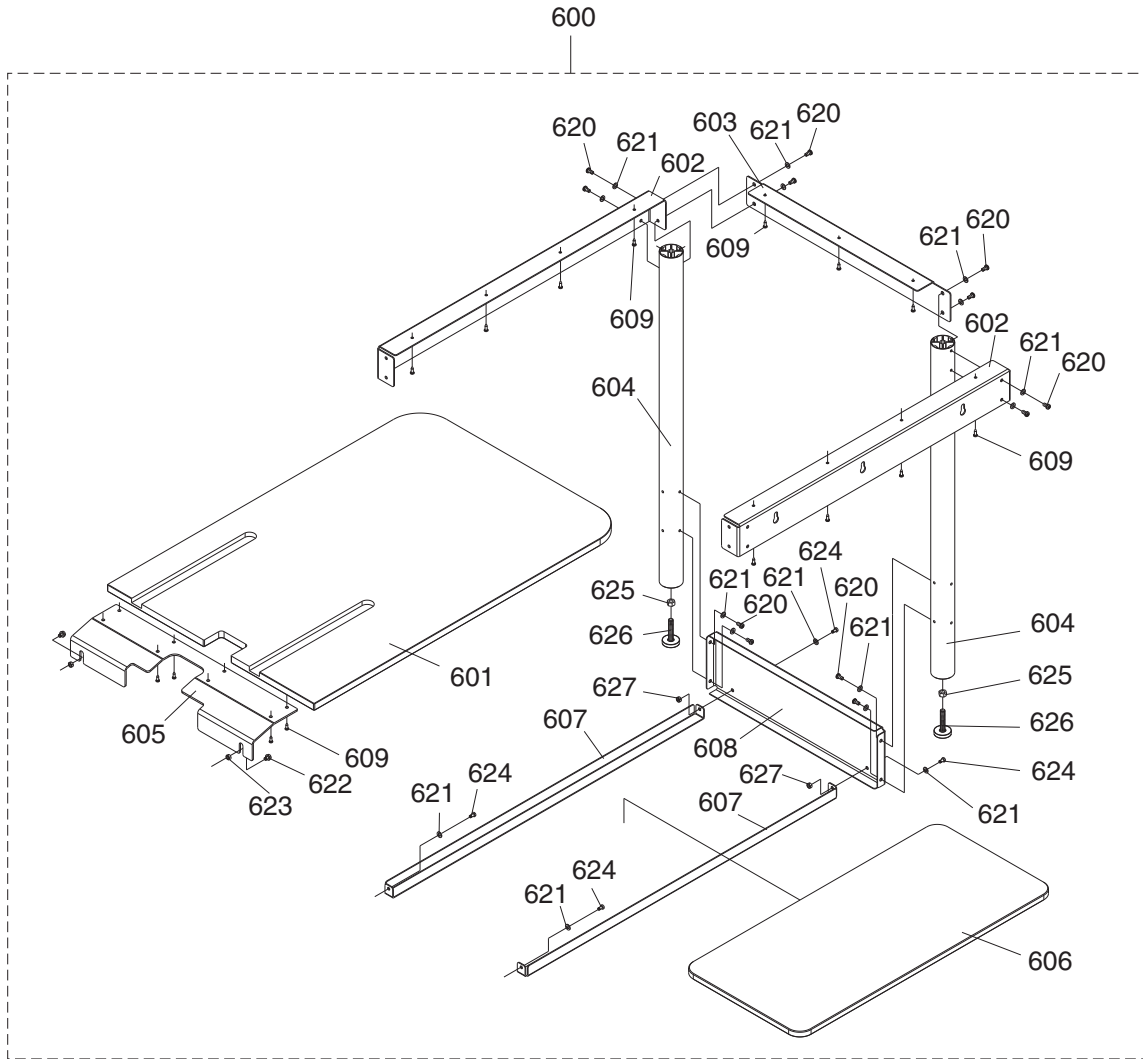


REF	PART #	DESCRIPTION
500	P0696X500	RAIL ASSEMBLY
501	P0696X501	REAR RAIL
502	P0696X502	END CAP
503	P0696X503	FENCE TUBE
504	P0696X504	FRONT RAIL
509	PW01M	FLAT WASHER 8MM
510	PLW04M	LOCK WASHER 8MM

REF	PART #	DESCRIPTION
511	PCAP31M	CAP SCREW M8-1.25 X 25
512	PFB15M	FLANGE BOLT M8-1.25 X 12
513	PFH21M	FLAT HD SCR M8-1.25 X 25
514	PN03M	HEX NUT M8-1.25
516	P0605X1501	LEFT SCALE 18"
517	P0696X517	RIGHT SCALE 36"



# Outfeed Table (G0605X1/G0606X1)

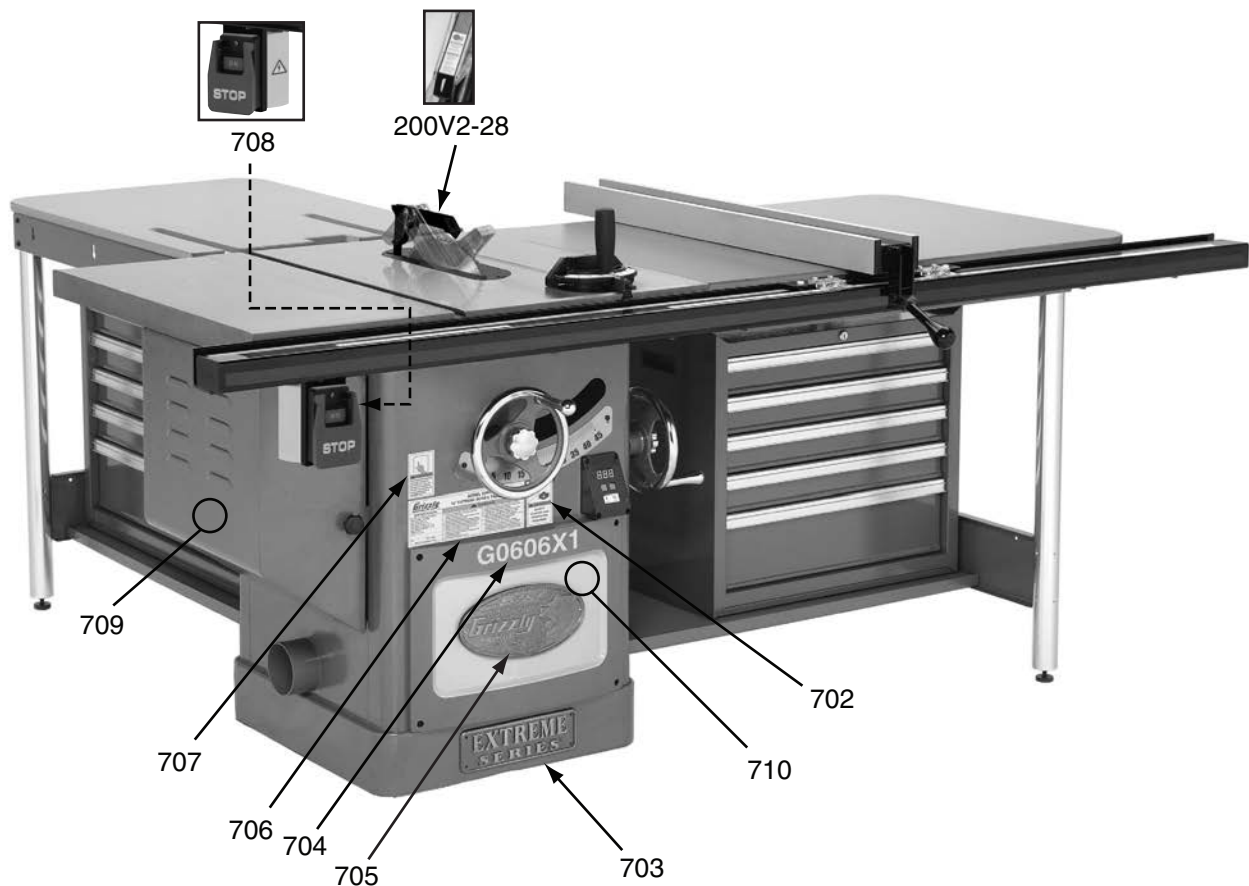


REF	PART #	DESCRIPTION
600	P0605X1600	OUTFEED TABLE ASSEMBLY
601	P0605X1601	OUTFEED TABLE PLATE
602	P0605X1602	OUTFEED TABLE SUPPORT
603	P0605X1603	REAR OUTFEED TABLE BRACKET
604	P0605X1604	SUPPORT LEG
605	P0605X1605	FRONT OUTFEED TABLE BRACKET
606	P0605X1606	LOWER SHELF
607	P0605X1607	LOWER SHELF BRACKET
608	P0605X1608	SHELF END PLATE

REF	PART #	DESCRIPTION
609	PHTEK6M	TAP SCREW M4 X 16
620	PS14M	PHLP HD SCR M6-1 X 12
621	PW03M	FLAT WASHER 6MM
622	PFB16M	FLANGE BOLT M8-1.25 X 16
623	PN03M	HEX NUT M8-1.25
624	PB02M	HEX BOLT M6-1 X 12
625	PN08	HEX NUT 3/8"-16
626	P0605X1626	FOOT 3/8"-16 X 2
627	PN01M	HEX NUT M6-1



# Labels & Cosmetic Parts



REF	PART #	DESCRIPTION
200V2-28	P0661002V2-28	AMPUTATION HAZ LABEL V2.01.10
702	PLABEL-57	GLASSES/RESPIRATOR 2W X 3.3H
703	H7942	EXTREME SERIES PLATE
704	P0605X1704	MODEL NUMBER LABEL
704	P0606X1704	MODEL # LABEL G0606X1
704	P0696X704	MODEL # LABEL G0696X
704	P0697X704	MODEL # LABEL G0697X
705	G8589	GRIZZLY NAMEPLATE-LARGE

REF	PART #	DESCRIPTION
706	P0605X1706	MACHINE ID LABEL G0605X1
706	P0606X1706	MACHINE ID LABEL G0606X1
706	P0696X706	MACHINE ID LABEL G0696X
706	P0697X706	MACHINE ID LABEL G0697X
707	PLABEL-12A	READ MANUAL-VERTICAL NS 7/05
708	PLABEL-14	ELECTRICITY LABEL
709	PPAINT-1	GRIZZLY GREEN PAINT
710	PPAINT-11	PUTTY TOUCH-UP PAINT

## WARNING

Safety labels warn about machine hazards and ways to prevent injury. The owner of this machine **MUST** maintain the original location and readability of the labels on the machine. If any label is removed or becomes unreadable, **REPLACE** that label before using the machine again. Contact Grizzly at (800) 523-4777 or [www.grizzly.com](http://www.grizzly.com) to order new labels.





# WARRANTY CARD

Name \_\_\_\_\_  
 Street \_\_\_\_\_  
 City \_\_\_\_\_ State \_\_\_\_\_ Zip \_\_\_\_\_  
 Phone # \_\_\_\_\_ Email \_\_\_\_\_  
 Model # \_\_\_\_\_ Order # \_\_\_\_\_ Serial # \_\_\_\_\_

The following information is given on a voluntary basis. It will be used for marketing purposes to help us develop better products and services. **Of course, all information is strictly confidential.**

1. How did you learn about us?

Advertisement                       Friend                       Catalog  
 Card Deck                                 Website                       Other:

2. Which of the following magazines do you subscribe to?

<input type="checkbox"/> Cabinetmaker & FDM	<input type="checkbox"/> Popular Science	<input type="checkbox"/> Wooden Boat
<input type="checkbox"/> Family Handyman	<input type="checkbox"/> Popular Woodworking	<input type="checkbox"/> Woodshop News
<input type="checkbox"/> Hand Loader	<input type="checkbox"/> Precision Shooter	<input type="checkbox"/> Woodsmith
<input type="checkbox"/> Handy	<input type="checkbox"/> Projects in Metal	<input type="checkbox"/> Woodwork
<input type="checkbox"/> Home Shop Machinist	<input type="checkbox"/> RC Modeler	<input type="checkbox"/> Woodworker West
<input type="checkbox"/> Journal of Light Cont.	<input type="checkbox"/> Rifle	<input type="checkbox"/> Woodworker's Journal
<input type="checkbox"/> Live Steam	<input type="checkbox"/> Shop Notes	<input type="checkbox"/> Other:
<input type="checkbox"/> Model Airplane News	<input type="checkbox"/> Shotgun News	
<input type="checkbox"/> Old House Journal	<input type="checkbox"/> Today's Homeowner	
<input type="checkbox"/> Popular Mechanics	<input type="checkbox"/> Wood	

3. What is your annual household income?

\$20,000-\$29,000                       \$30,000-\$39,000                       \$40,000-\$49,000  
 \$50,000-\$59,000                       \$60,000-\$69,000                       \$70,000+

4. What is your age group?

20-29     30-39     40-49  
 50-59     60-69     70+

5. How long have you been a woodworker/metalworker?

0-2 Years                       2-8 Years                       8-20 Years                       20+ Years

6. How many of your machines or tools are Grizzly?

0-2                       3-5                       6-9                       10+

7. Do you think your machine represents a good value?                       Yes                       No

8. Would you recommend Grizzly Industrial to a friend?                       Yes                       No

9. Would you allow us to use your name as a reference for Grizzly customers in your area?

**Note:** We never use names more than 3 times.                       Yes                       No

10. Comments: \_\_\_\_\_  
 \_\_\_\_\_  
 \_\_\_\_\_  
 \_\_\_\_\_

CUT ALONG DOTTED LINE

FOLD ALONG DOTTED LINE

\_\_\_\_\_  
\_\_\_\_\_  
\_\_\_\_\_



Place  
Stamp  
Here



**GRIZZLY INDUSTRIAL, INC.**  
P.O. BOX 2069  
BELLINGHAM, WA 98227-2069



FOLD ALONG DOTTED LINE

Send a Grizzly Catalog to a friend:

Name \_\_\_\_\_  
Street \_\_\_\_\_  
City \_\_\_\_\_ State \_\_\_\_\_ Zip \_\_\_\_\_

TAPE ALONG EDGES--PLEASE DO NOT STAPLE

# WARRANTY AND RETURNS

---

Grizzly Industrial, Inc. warrants every product it sells for a period of **1 year** to the original purchaser from the date of purchase. This warranty does not apply to defects due directly or indirectly to misuse, abuse, negligence, accidents, repairs or alterations or lack of maintenance. This is Grizzly's sole written warranty and any and all warranties that may be implied by law, including any merchantability or fitness, for any particular purpose, are hereby limited to the duration of this written warranty. We do not warrant or represent that the merchandise complies with the provisions of any law or acts unless the manufacturer so warrants. In no event shall Grizzly's liability under this warranty exceed the purchase price paid for the product and any legal actions brought against Grizzly shall be tried in the State of Washington, County of Whatcom.

We shall in no event be liable for death, injuries to persons or property or for incidental, contingent, special, or consequential damages arising from the use of our products.

To take advantage of this warranty, contact us by mail or phone and give us all the details. We will then issue you a "Return Number," which must be clearly posted on the outside as well as the inside of the carton. We will not accept any item back without this number. Proof of purchase must accompany the merchandise.

The manufacturers reserve the right to change specifications at any time because they constantly strive to achieve better quality equipment. We make every effort to ensure that our products meet high quality and durability standards and we hope you never need to use this warranty.

Please feel free to write or call us if you have any questions about the machine or the manual.

Thank you again for your business and continued support. We hope to serve you again soon.

***grizzly.com***<sup>®</sup>  
**TOOL WEBSITE**

Buy Direct and Save with Grizzly<sup>®</sup> – Trusted, Proven and a Great Value!  
~Since 1983~

*Visit Our Website Today For  
Current Specials!*

**ORDER  
24 HOURS A DAY!  
1-800-523-4777**

