

Grizzly *Industrial, Inc.*®

MODEL G0555 **ULTIMATE 14" BANDSAW** **OWNER'S MANUAL** *(For models manufactured since 05/11)*



COPYRIGHT © AUGUST, 2002 GRIZZLY INDUSTRIAL, INC., REVISED AUGUST, 2023 (MN)
**WARNING: NO PORTION OF THIS MANUAL MAY BE REPRODUCED IN ANY SHAPE
OR FORM WITHOUT THE WRITTEN APPROVAL OF GRIZZLY INDUSTRIAL, INC.**
#TR4508 PRINTED IN TAIWAN

V4.08.23

*****Keep for Future Reference*****

 **WARNING!**

This manual provides critical safety instructions on the proper setup, operation, maintenance, and service of this machine/tool. Save this document, refer to it often, and use it to instruct other operators.

Failure to read, understand and follow the instructions in this manual may result in fire or serious personal injury—including amputation, electrocution, or death.

The owner of this machine/tool is solely responsible for its safe use. This responsibility includes but is not limited to proper installation in a safe environment, personnel training and usage authorization, proper inspection and maintenance, manual availability and comprehension, application of safety devices, cutting/sanding/grinding tool integrity, and the usage of personal protective equipment.

The manufacturer will not be held liable for injury or property damage from negligence, improper training, machine modifications or misuse.

 **WARNING!**

Some dust created by power sanding, sawing, grinding, drilling, and other construction activities contains chemicals known to the State of California to cause cancer, birth defects or other reproductive harm. Some examples of these chemicals are:

- **Lead from lead-based paints.**
- **Crystalline silica from bricks, cement and other masonry products.**
- **Arsenic and chromium from chemically-treated lumber.**

Your risk from these exposures varies, depending on how often you do this type of work. To reduce your exposure to these chemicals: Work in a well ventilated area, and work with approved safety equipment, such as those dust masks that are specially designed to filter out microscopic particles.

Table of Contents

INTRODUCTION	2	SECTION 5: ACCESSORIES	40
Contact Info	2	SECTION 6: MAINTENANCE	41
Manual Accuracy	2	Schedule	41
Identification.....	3	Cleaning & Protecting	41
Machine Data Sheet	4	Lubrication	42
SECTION 1: SAFETY	6	Redressing Rubber Tires	42
Safety Instructions for Machinery	6	SECTION 7: SERVICE	43
Additional Safety for Bandsaws.....	8	Troubleshooting	43
SECTION 2: POWER SUPPLY	9	V-Belt Tension	45
SECTION 3: SETUP	12	Replacing V-Belt	46
Needed for Setup.....	12	Shimming Table	46
Unpacking.....	12	Wheel Alignment.....	47
Inventory	13	Blade Lead.....	50
Hardware Recognition Chart	14	Blade Tensioner	51
Cleanup.....	15	Fence Scale Calibration.....	52
Site Considerations.....	16	SECTION 8: WIRING	53
Assembly	17	Wiring Safety Instructions	53
Blade Center Tracking	21	Wiring Diagram	54
Dust Collection.....	22	SECTION 9: PARTS	55
Test Run.....	23	Main	55
Tensioning Blade	24	Stand.....	58
Adjusting Blade Support Bearings	24	Fence	59
Adjusting Blade Guide Bearings	26	Labels & Cosmetics	60
Table Tilt Calibration	27	WARRANTY & RETURNS	61
Aligning Table.....	28		
Aligning Fence.....	29		
SECTION 4: OPERATIONS	30		
Operation Overview	30		
Disabling & Locking Switch	31		
Workpiece Inspection.....	31		
Guide Post	32		
Table Tilt.....	32		
Blade Speed	33		
Blade Information.....	34		
Blade Change	36		
Basic Cutting Tips	37		
Cutting Options	37		
Ripping.....	37		
Crosscutting.....	38		
Resawing	38		
Cutting Curves	39		
Stacked Cuts	39		

INTRODUCTION

Contact Info

We stand behind our machines! If you have questions or need help, contact us with the information below. Before contacting, make sure you get the **serial number** and **manufacture date** from the machine ID label. This will help us help you faster.

Grizzly Technical Support
1815 W. Battlefield
Springfield, MO 65807
Phone: (570) 546-9663
Email: techsupport@grizzly.com

We want your feedback on this manual. What did you like about it? Where could it be improved? Please take a few minutes to give us feedback.

Grizzly Documentation Manager
P.O. Box 2069
Bellingham, WA 98227-2069
Email: manuals@grizzly.com

WARNING

Like all machinery there is potential danger when operating this machine. Accidents are frequently caused by lack of familiarity or failure to pay attention. Use this machine with respect and caution to decrease the risk of operator injury. If normal safety precautions are overlooked or ignored, serious personal injury may occur.

CAUTION

No list of safety guidelines can be complete. Every shop environment is different. Always consider safety first, as it applies to your individual working conditions. Use this and other machinery with caution and respect. Failure to do so could result in serious personal injury, damage to equipment, or poor work results.



Manual Accuracy

We are proud to provide a high-quality owner's manual with your new machine!

We made every effort to be exact with the instructions, specifications, drawings, and photographs in this manual. Sometimes we make mistakes, but our policy of continuous improvement also means that **sometimes the machine you receive is slightly different than shown in the manual.**

If you find this to be the case, and the difference between the manual and machine leaves you confused or unsure about something, check our website for an updated version. We post current manuals and manual updates for free on our website at www.grizzly.com.

Alternatively, you can call our Technical Support for help. Before calling, make sure you write down the **manufacture date** and **serial number** from the machine ID label (see below). This information is required for us to provide proper tech support, and it helps us determine if updated documentation is available for your machine.

		MODEL GXXXX MACHINE NAME	
SPECIFICATIONS		 WARNING!	
Motor:		To reduce risk of serious injury when using this machine:	
Specification:		1. Read manual before operation.	
Specification:		2. Wear safety glasses and respirator.	
Specification:		3. Make sure power is connected to grounded circuit before starting.	
Specification:		4. Make sure the motor has stopped and disconnect power before adjustments, maintenance, or service.	
Weight:		5. DO NOT expose to rain or dampness.	
		6. DO NOT modify this machine in any way.	
		7.	
		8.	
		9. Do not use while under the influence of drugs or alcohol.	
		10. Maintain machine carefully to prevent accidents.	
		Manufactured for Grizzly in Taiwan	

Manufacture Date

Serial Number



Identification

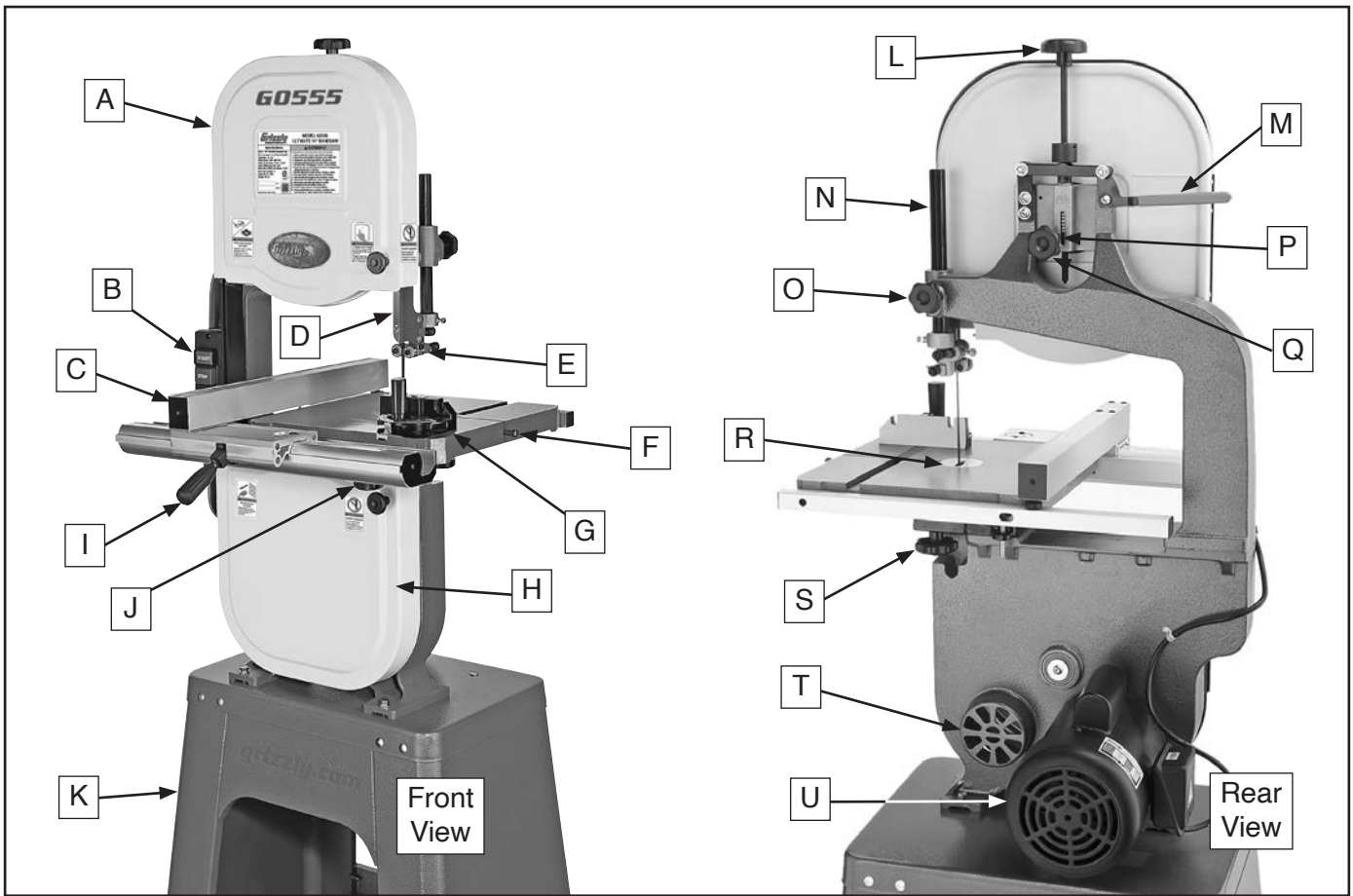

- A. Upper Wheel Cover
- B. ON/OFF Switch w/Disabling Padlock
- C. Fence
- D. Blade Guard
- E. Upper Blade Guide Assembly
- F. Table Pin
- G. Miter Gauge Assembly
- H. Lower Wheel Cover
- I. Fence Lock Lever
- J. Front Table Lock Knob
- K. Stand Assembly

- L. Blade Tension Adjustment Knob
- M. Blade Tension Quick Release Lever
- N. Guide Post
- O. Guide Post Lock Knob
- P. Blade Tension Scale
- Q. Blade Tracking Adjustment Knob
- R. Table Insert
- S. Rear Table Lock Knob
- T. 4" Dust Port
- U. Motor

⚠️ WARNING

For Your Own Safety, Read Instruction Manual Before Operating Saw.

- a) **Wear eye protection.**
- b) **Do not remove jammed cutoff pieces until blade has stopped.**
- c) **Maintain proper adjustment of blade tension, blade guides, and support bearings.**
- d) **Adjust upper blade guide to just clear workpiece.**
- e) **Hold workpiece firmly against table.**





MACHINE DATA SHEET

Customer Service #: (570) 546-9663 · To Order Call: (800) 523-4777 · Fax #: (800) 438-5901

MODEL G0555 ULTIMATE 14" BANDSAW

Product Dimensions:

Weight..... 190 lbs.
 Width (side-to-side) x Depth (front-to-back) x Height..... 26-1/2 x 30-1/2 x 66-1/2 in.
 Footprint (Length x Width)..... 24-1/2 x 17-1/2 in.

Shipping Dimensions:

Type..... Cardboard Box
 Content..... Machine
 Weight..... 207 lbs.
 Length x Width x Height..... 44 x 21 x 20 in.
 Must Ship Upright..... No

Electrical:

Power Requirement..... 110V or 220V, Single-Phase, 60 Hz
 Prewired Voltage..... 110V
 Full-Load Current Rating..... 11A at 110V, 5.5A at 220V
 Minimum Circuit Size..... 15A at 110V, 15A at 220V
 Connection Type..... Cord & Plug
 Power Cord Included..... Yes
 Power Cord Length..... 72 in.
 Power Cord Gauge..... 16 AWG
 Plug Included..... Yes
 Included Plug Type..... 5-15 for 110V
 Recommended Plug Type..... 6-15 for 220V
 Switch Type..... ON/OFF Push Button Switch

Motors:

Main

Horsepower..... 1 HP
 Phase..... Single-Phase
 Amps..... 11A/5.5A
 Speed..... 1720 RPM
 Type..... TEFC Capacitor-Start Induction
 Power Transfer..... Belt
 Bearings..... Shielded & Permanently Lubricated
 Centrifugal Switch/Contacts Type..... External

Main Specifications:

Main Specifications

Bandsaw Size..... 14 in.
 Max Cutting Width (Left of Blade)..... 13-1/2 in.
 Max Cutting Width (Left of Blade) w/Fence..... 11-7/8 in.
 Max Cutting Height (Resaw Height)..... 6 in.
 Blade Speeds..... 1500, 3200 FPM



Blade Information

Standard Blade Length..... 93-1/2 in.
Blade Length Range..... 92-1/2 – 93-1/2 in.
Blade Width Range..... 1/8 – 3/4 in.
Type of Blade Guides..... Ball Bearing
Guide Post Adjustment Type..... Manual
Has Quick-Release..... Yes

Table Information

Table Length..... 14 in.
Table Width..... 14 in.
Table Thickness..... 1-1/2 in.
Table Tilt..... Left 15, Right 45 deg.
Table Tilt Adjustment Type..... Manual
Floor-to-Table Height..... 43-5/16 in.
Fence Locking Position..... Front
Fence is Adjustable for Blade Lead..... Yes
Resaw Fence Attachment Included..... No
Miter Gauge Included..... Yes

Miter Gauge Information

Miter Angle..... 0 - 60 deg. L/R
Miter Gauge Slot Type..... Straight Slot
Miter Gauge Slot Width..... 3/4 in.
Miter Gauge Slot Height..... 3/8 in.

Construction Materials

Table..... Precision Ground Cast Iron
Trunnion..... Aluminum
Fence..... Deluxe Extruded Aluminum
Base/Stand..... Pre-Formed Steel
Frame/Body..... Cast Iron
Wheels..... Computer-Balanced Cast Aluminum
Tire..... Rubber
Wheel Cover Pre-Formed Steel
Paint Type/Finish..... Powder Coating & Ure

Other Related Information

Wheel Diameter..... 13-3/4 in.
Wheel Width..... 1-3/16 in.
Number of Dust Ports..... 1
Dust Port Size..... 4 in.
Compatible Mobile Base..... D2057A

Other Specifications:

Country of Origin Taiwan
Warranty 1 Year
Approximate Assembly & Setup Time 1 Hour
Serial Number Location ID Label
ISO 9001 Factory Yes
Certified by a Nationally Recognized Testing Laboratory (NRTL) Yes



SECTION 1: SAFETY

For Your Own Safety, Read Instruction Manual Before Operating This Machine

The purpose of safety symbols is to attract your attention to possible hazardous conditions. This manual uses a series of symbols and signal words intended to convey the level of importance of the safety messages. The progression of symbols is described below. Remember that safety messages by themselves do not eliminate danger and are not a substitute for proper accident prevention measures. Always use common sense and good judgment.



Indicates an imminently hazardous situation which, if not avoided, **WILL** result in death or serious injury.



Indicates a potentially hazardous situation which, if not avoided, **COULD** result in death or serious injury.



Indicates a potentially hazardous situation which, if not avoided, **MAY** result in minor or moderate injury. It may also be used to alert against unsafe practices.

NOTICE

Alerts the user to useful information about proper operation of the machine to avoid machine damage.

Safety Instructions for Machinery



OWNER'S MANUAL. Read and understand this owner's manual **BEFORE** using machine.

TRAINED OPERATORS ONLY. Untrained operators have a higher risk of being hurt or killed. Only allow trained/supervised people to use this machine. When machine is not being used, disconnect power, remove switch keys, or lock-out machine to prevent unauthorized use—especially around children. Make your workshop kid proof!

DANGEROUS ENVIRONMENTS. Do not use machinery in areas that are wet, cluttered, or have poor lighting. Operating machinery in these areas greatly increases the risk of accidents and injury.

MENTAL ALERTNESS REQUIRED. Full mental alertness is required for safe operation of machinery. Never operate under the influence of drugs or alcohol, when tired, or when distracted.

ELECTRICAL EQUIPMENT INJURY RISKS.

You can be shocked, burned, or killed by touching live electrical components or improperly grounded machinery. To reduce this risk, only allow qualified service personnel to do electrical installation or repair work, and always disconnect power before accessing or exposing electrical equipment.

DISCONNECT POWER FIRST. Always disconnect machine from power supply **BEFORE** making adjustments, changing tooling, or servicing machine. This prevents an injury risk from unintended startup or contact with live electrical components.

EYE PROTECTION. Always wear ANSI-approved safety glasses or a face shield when operating or observing machinery to reduce the risk of eye injury or blindness from flying particles. Everyday eyeglasses are **NOT** approved safety glasses.



WARNING

WEARING PROPER APPAREL. Do not wear loose clothing, gloves, neckties, or jewelry that can become entangled in moving parts. Always tie back or cover long hair. Wear non-slip footwear to reduce risk of slipping and losing control or accidentally contacting cutting tool or moving parts.

HAZARDOUS DUST. Dust created by machinery operations may cause cancer, birth defects, or long-term respiratory damage. Be aware of dust hazards associated with each workpiece material. Always wear a NIOSH-approved respirator to reduce your risk.

HEARING PROTECTION. Always wear hearing protection when operating or observing loud machinery. Extended exposure to this noise without hearing protection can cause permanent hearing loss.

REMOVE ADJUSTING TOOLS. Tools left on machinery can become dangerous projectiles upon startup. Never leave chuck keys, wrenches, or any other tools on machine. Always verify removal before starting!

USE CORRECT TOOL FOR THE JOB. Only use this tool for its intended purpose—do not force it or an attachment to do a job for which it was not designed. Never make unapproved modifications—modifying tool or using it differently than intended may result in malfunction or mechanical failure that can lead to personal injury or death!

AWKWARD POSITIONS. Keep proper footing and balance at all times when operating machine. Do not overreach! Avoid awkward hand positions that make workpiece control difficult or increase the risk of accidental injury.

CHILDREN & BYSTANDERS. Keep children and bystanders at a safe distance from the work area. Stop using machine if they become a distraction.

GUARDS & COVERS. Guards and covers reduce accidental contact with moving parts or flying debris. Make sure they are properly installed, undamaged, and working correctly BEFORE operating machine.

FORCING MACHINERY. Do not force machine. It will do the job safer and better at the rate for which it was designed.

NEVER STAND ON MACHINE. Serious injury may occur if machine is tipped or if the cutting tool is unintentionally contacted.

STABLE MACHINE. Unexpected movement during operation greatly increases risk of injury or loss of control. Before starting, verify machine is stable and mobile base (if used) is locked.

USE RECOMMENDED ACCESSORIES. Consult this owner's manual or the manufacturer for recommended accessories. Using improper accessories will increase the risk of serious injury.

UNATTENDED OPERATION. To reduce the risk of accidental injury, turn machine **OFF** and ensure all moving parts completely stop before walking away. Never leave machine running while unattended.

MAINTAIN WITH CARE. Follow all maintenance instructions and lubrication schedules to keep machine in good working condition. A machine that is improperly maintained could malfunction, leading to serious personal injury or death.

DAMAGED PARTS. Regularly inspect machine for damaged, loose, or mis-adjusted parts—or any condition that could affect safe operation. Immediately repair/replace BEFORE operating machine. For your own safety, DO NOT operate machine with damaged parts!

MAINTAIN POWER CORDS. When disconnecting cord-connected machines from power, grab and pull the plug—NOT the cord. Pulling the cord may damage the wires inside. Do not handle cord/plug with wet hands. Avoid cord damage by keeping it away from heated surfaces, high traffic areas, harsh chemicals, and wet/damp locations.

EXPERIENCING DIFFICULTIES. If at any time you experience difficulties performing the intended operation, stop using the machine! Contact our Technical Support at (570) 546-9663.



Additional Safety for Bandsaws

WARNING

Serious cuts, amputation, or death can occur from contact with the moving saw blade during operation or if blade breakage occurs. Serious injury or death can also occur from getting fingers, hair, or clothing entangled in moving parts if the machine is operated while the doors are open. To reduce this risk, anyone operating this machine **MUST** completely heed the hazards and warnings below.

HAND PLACEMENT. Placing hands or fingers in line with blade during operation may result in serious injury if hands slip or workpiece moves unexpectedly. Do not position fingers or hands in line with blade, and never reach under table while blade is moving.

SMALL/NARROW WORKPIECES. If hands slip during a cut while holding small workpieces with fingers, serious personal injury could occur. Always support/feed small or narrow workpieces with push sticks, push blocks, jig, vise, clamping fixture.

BLADE SPEED. Cutting workpiece before blade is at full speed could cause blade to grab workpiece and pull hands into blade. Allow blade to reach full speed before starting cut. **DO NOT** start machine with workpiece contacting blade.

FEED RATE. To avoid risk of workpiece slipping and causing operator injury, always feed stock evenly and smoothly.

BLADE CONDITION. Dull blades require more effort to perform cut, increasing risk of accidents. Do not operate with dirty, dull, cracked or badly worn blades. Inspect blades for cracks and missing teeth before each use. Always maintain proper blade tension and tracking while operating.

CLEARING JAMS AND CUTOFFS. Always stop bandsaw and disconnect power before clearing scrap pieces that get stuck between blade and table insert. Use brush or push stick, not hands, to clean chips/cutoff scraps from table.

BLADE CONTROL. To avoid risk of injury due to blade contact, always allow blade to stop on its own. **DO NOT** try to stop or slow blade with your hand or the workpiece.

GUARDS/COVERS. Blade guards and covers protect operator from moving bandsaw blade. The wheel covers protect operator from getting entangled with rotating wheels or other moving parts. **ONLY** operate bandsaw with blade guard in proper position and wheel covers completely closed.

BLADE REPLACEMENT. To avoid mishaps that could result in operator injury, make sure blade teeth face down toward table and blade is properly tensioned and tracked before operating.

UPPER BLADE GUIDE SUPPORT. To reduce exposure of operator to blade and provide maximum blade support while cutting, keep upper blade guides adjusted to just clear workpiece.

CUTTING TECHNIQUES. To avoid blade getting pulled off wheels or accidentally breaking and striking operator, always turn bandsaw **OFF** and wait for blade to come to a complete stop before backing workpiece out of blade. **DO NOT** back workpiece away from blade while bandsaw is running. **DO NOT** force or twist blade while cutting, especially when sawing small curves. This could result in blade damage or breakage.

WORKPIECE SUPPORT. To maintain maximum control and reduce risk of blade contact/breakage, always ensure adequate support of long/large workpieces. Always keep workpiece flat and firm against table/fence when cutting to avoid loss of control. If necessary, use a jig or other workholding device.

WORKPIECE MATERIAL. This machine is intended for cutting natural and man-made wood products, and laminate covered wood products. This machine is **NOT** designed to cut metal, glass, stone, tile, etc.



SECTION 2: POWER SUPPLY

Availability

Before installing the machine, consider the availability and proximity of the required power supply circuit. If an existing circuit does not meet the requirements for this machine, a new circuit must be installed. To minimize the risk of electrocution, fire, or equipment damage, installation work and electrical wiring must be done by an electrician or qualified service personnel in accordance with all applicable codes and standards.

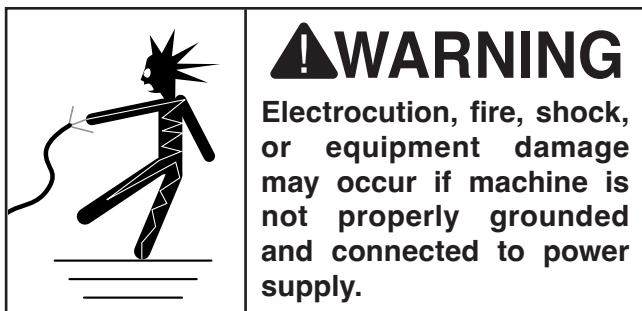

Full-Load Current Rating

The full-load current rating is the amperage a machine draws at 100% of the rated output power. On machines with multiple motors, this is the amperage drawn by the largest motor or sum of all motors and electrical devices that might operate at one time during normal operations.

Full-Load Current Rating at 110V 11 Amps

Full-Load Current Rating at 220V 5.5 Amps

The full-load current is not the maximum amount of amps that the machine will draw. If the machine is overloaded, it will draw additional amps beyond the full-load rating.

If the machine is overloaded for a sufficient length of time, damage, overheating, or fire may result—especially if connected to an undersized circuit. To reduce the risk of these hazards, avoid overloading the machine during operation and make sure it is connected to a power supply circuit that meets the specified circuit requirements.

Circuit Information

A power supply circuit includes all electrical equipment between the breaker box or fuse panel in the building and the machine. The power supply circuit used for this machine must be sized to safely handle the full-load current drawn from the machine for an extended period of time. (If this machine is connected to a circuit protected by fuses, use a time delay fuse marked D.)

⚠ CAUTION

For your own safety and protection of property, consult an electrician if you are unsure about wiring practices or electrical codes in your area.

Note: *Circuit requirements in this manual apply to a dedicated circuit—where only one machine will be running on the circuit at a time. If machine will be connected to a shared circuit where multiple machines may be running at the same time, consult an electrician or qualified service personnel to ensure circuit is properly sized for safe operation.*

Circuit Requirements for 110V

This machine can be converted to operate on a 110V power supply (refer to **Voltage Conversion** instructions) that has a verified ground and meets the following requirements:

Nominal Voltage 110V/120V
Cycle.....60 Hz
Phase..... Single-Phase
Circuit Rating..... 15 Amps
Plug/Receptacle NEMA 5-15

Circuit Requirements for 220V

This machine can be converted to operate on a 220V power supply (refer to **Voltage Conversion** instructions). This power supply must have a verified ground and meet the following requirements:

Nominal Voltage 220V/240V
Cycle.....60 Hz
Phase..... Single-Phase
Circuit Rating..... 15 Amps
Plug/Receptacle NEMA 6-15



Grounding Requirements

This machine **MUST** be grounded. In the event of certain malfunctions or breakdowns, grounding reduces the risk of electric shock by providing a path of least resistance for electric current.

For 110V operation: This machine is equipped with a power cord that has an equipment-grounding wire and a grounding plug (see following figure). The plug must only be inserted into a matching receptacle (outlet) that is properly installed and grounded in accordance with all local codes and ordinances.

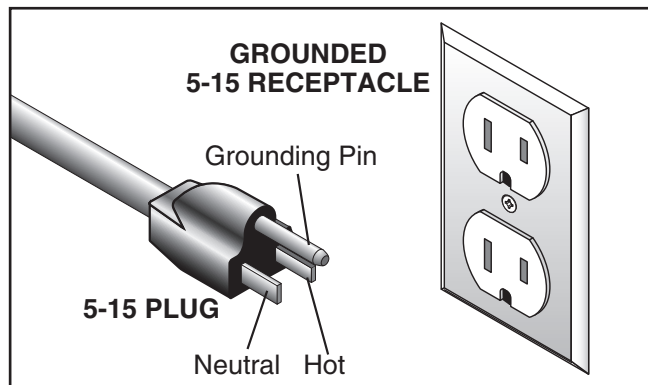

Figure 1. Typical 5-15 plug and receptacle.

⚠ CAUTION

SHOCK HAZARD!

Two-prong outlets do not meet the grounding requirements for this machine. Do not modify or use an adapter on the plug provided—if it will not fit the outlet, have a qualified electrician install the proper outlet with a verified ground.

For 220V operation: The plug specified under “Circuit Requirements for 220V” on the previous page has a grounding prong that must be attached to the equipment-grounding wire on the included power cord. The plug must only be inserted into a matching receptacle (see following figure) that is properly installed and grounded in accordance with all local codes and ordinances.

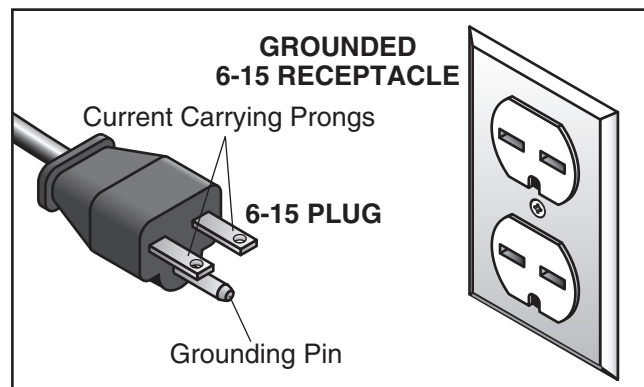

Figure 2. Typical 6-15 plug and receptacle.

Improper connection of the equipment-grounding wire can result in a risk of electric shock. The wire with green insulation (with or without yellow stripes) is the equipment-grounding wire. If repair or replacement of the power cord or plug is necessary, do not connect the equipment-grounding wire to a live (current carrying) terminal.

Check with a qualified electrician or service personnel if you do not understand these grounding requirements, or if you are in doubt about whether the machine is properly grounded. If you ever notice that a cord or plug is damaged or worn, disconnect it from power, and immediately replace it with a new one.



Extension Cords

We do not recommend using an extension cord with this machine. If you must use an extension cord, only use it if absolutely necessary and only on a temporary basis.

Extension cords cause voltage drop, which can damage electrical components and shorten motor life. Voltage drop increases as the extension cord size gets longer and the gauge size gets smaller (higher gauge numbers indicate smaller sizes).

Any extension cord used with this machine must be in good condition and contain a ground wire and matching plug/receptacle. Additionally, it must meet the following size requirements:

Minimum Gauge Size14 AWG
Maximum Length (Shorter is Better).....50 ft.

Voltage Conversion

The voltage conversion **MUST** be performed by a electrician or qualified service personnel. To perform the voltage conversion, install the correct plug and rewire the motor to the new voltage, according to the provided wiring diagram on **Page 54**.

Note: *If the diagram included on the motor conflicts with the one in this manual, the motor may have changed since the manual was printed. Use the diagram provided inside the motor wiring junction box.*

To convert the machine to 220V:

1. DISCONNECT MACHINE FROM POWER!
2. Replace the 5-15 plug on the power cord with a 6-15 plug.
3. Re-wire the motor as illustrated in the wiring diagram.



SECTION 3: SETUP

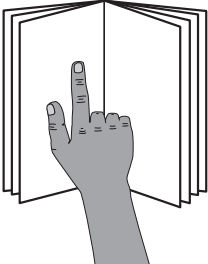

!WARNING
This machine presents serious injury hazards to untrained users. Read through this entire manual to become familiar with the controls and operations before starting the machine!



!WARNING
Wear safety glasses during the entire setup process!

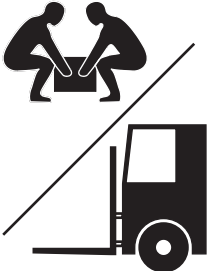

!WARNING
HEAVY LIFT!
Straining or crushing injury may occur from improperly lifting machine or some of its parts. To reduce this risk, get help from other people and use a forklift (or other lifting equipment) rated for weight of this machine.

Needed for Setup

The following items are needed, but not included, for the setup/assembly of this machine.

The following are needed to complete the setup process, but are not included with your machine.

Description	Qty
• Safety Glasses	1
• Cleaner/Degreaser	As Needed
• Disposable Shop Rags.....	As Needed
• Additional People for Lifting	At Least 1
• Level	1
• Hex Wrench 5mm.....	1
• Wrench or Socket 10mm.....	2
• Wrench or Socket 13mm.....	2
• Dust Collection System	1
• Dust Hose 4"	1
• Hose Clamps 4"	2

Unpacking

This machine was carefully packaged for safe transport. When unpacking, separate all enclosed items from packaging materials and inspect them for shipping damage. ***If items are damaged, please call us immediately at (570) 546-9663.***

IMPORTANT: Save all packaging materials until you are completely satisfied with the machine and have resolved any issues between Grizzly or the shipping agent. *You MUST have the original packaging to file a freight claim. It is also extremely helpful if you need to return your machine later.*



Inventory

The following is a list of items shipped with your machine. Before beginning setup, lay these items out and inventory them.

If any non-proprietary parts are missing (e.g. a nut or a washer), we will gladly replace them; or for the sake of expediency, replacements can be obtained at your local hardware store.

Shipping Inventory: (Figures 3–5)	Qty
A. Bandsaw Assembly.....	1
B. Upper Stand Braces.....	2
C. Stand Top.....	1
D. Miter Gauge Assembly.....	1
E. Stand Sides.....	2
F. Table w/Insert & Table Pin.....	1
G. Table Trunnion.....	1
H. Table Lock Knobs $\frac{3}{8}$ "-16.....	2
I. Lower Stand Braces.....	2
J. Front Fence Rail.....	1
K. Rear Fence Rail.....	1
L. Fence Assembly.....	1
M. Hardware (Not Shown):	
—Hex Bolts M6-1 x 16 (Stand).....	16
—Flat Washers 6mm (Stand).....	16
—Flange Nuts M6-1 (Stand).....	16
—Stand Feet $\frac{3}{8}$ "-16 x 2" (Stand).....	4
—Hex Nuts $\frac{3}{8}$ "-16 (Stand Feet).....	8
—Flat Washers $\frac{3}{8}$ " (Stand Feet).....	8
—Carriage Bolts M8-1.25 x 16 (Stand).....	8
—Flange Nuts M8-1.25 (Stand).....	8
—Hex Bolts M8-1.25 x 35 (Bandsaw).....	4
—Flat Washers 8mm (Bandsaw).....	8
—Lock Washers 8mm (Bandsaw).....	4
—Hex Nuts M8-1.25 (Bandsaw).....	4
—Hex Bolts M8-1.25 x 30 (Trunnion).....	2
—Lock Washers 8mm (Trunnion).....	2
—Hex Bolt M8-1.25 x 80 (Positive Stop)....	1
—Hex Nut M8-1.25 (Positive Stop).....	1
—Fence Stand-Off M6-1 x 20 (Fence).....	1
—Lock Handle M8-1.25 x 20 (Fence).....	1
—Cap Screws M6-1 x 16 Black (Fence)....	2
—Hex Bolts M6-1 x 20 Black (Fence).....	2
—Lock Washers 6mm Black (Fence).....	2
—Flat Washers 6mm Black (Fence).....	2
—Hex Nut M8-1.25 Black (Fence).....	1
—Hex Nut M6-1 Black (Fence).....	1

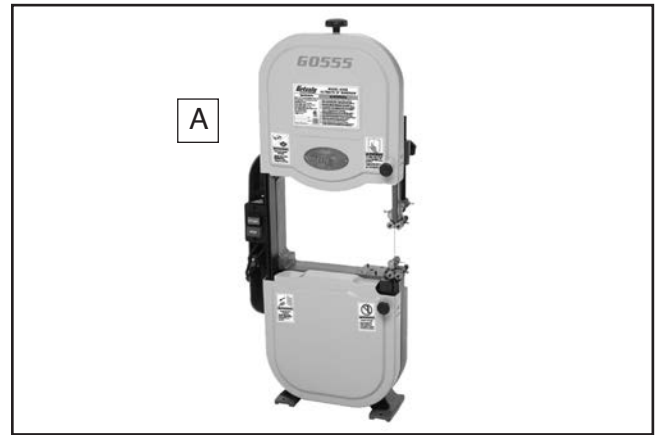

Figure 3. Bandsaw assembly.

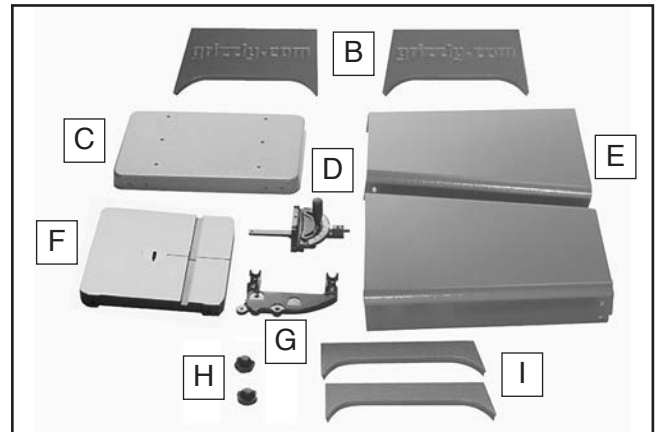

Figure 4. Other components.

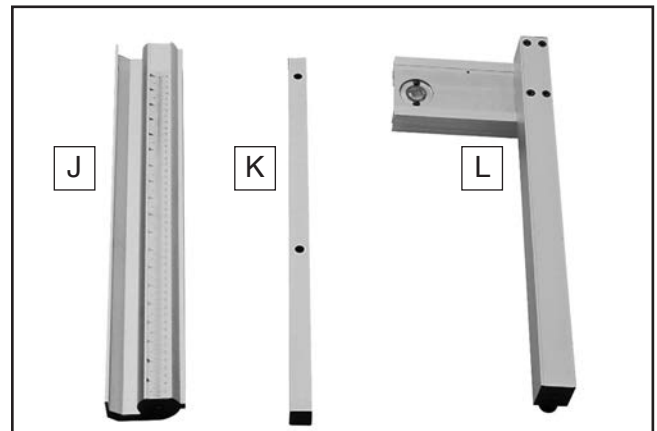

Figure 5. Fence components.

NOTICE

If you cannot find an item on this list, carefully check around/inside the machine and packaging materials. Often, these items get lost in packaging materials while unpacking or they are pre-installed at the factory.



Hardware Recognition Chart

USE THIS CHART TO MATCH UP HARDWARE DURING THE ASSEMBLY PROCESS.

MEASURE BOLT DIAMETER BY PLACING INSIDE CIRCLE

- #10
- 1/4"
- 5/16"
- 3/8"
- 7/16"
- 1/2"

- 4mm
- 5mm
- 6mm
- 8mm
- 10mm
- 12mm
- 16mm

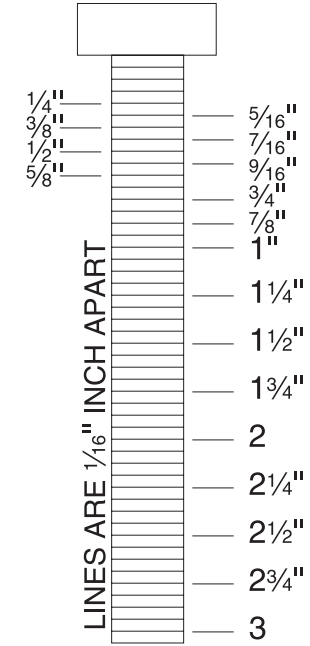
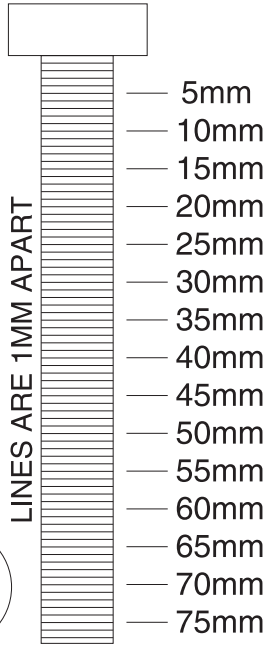
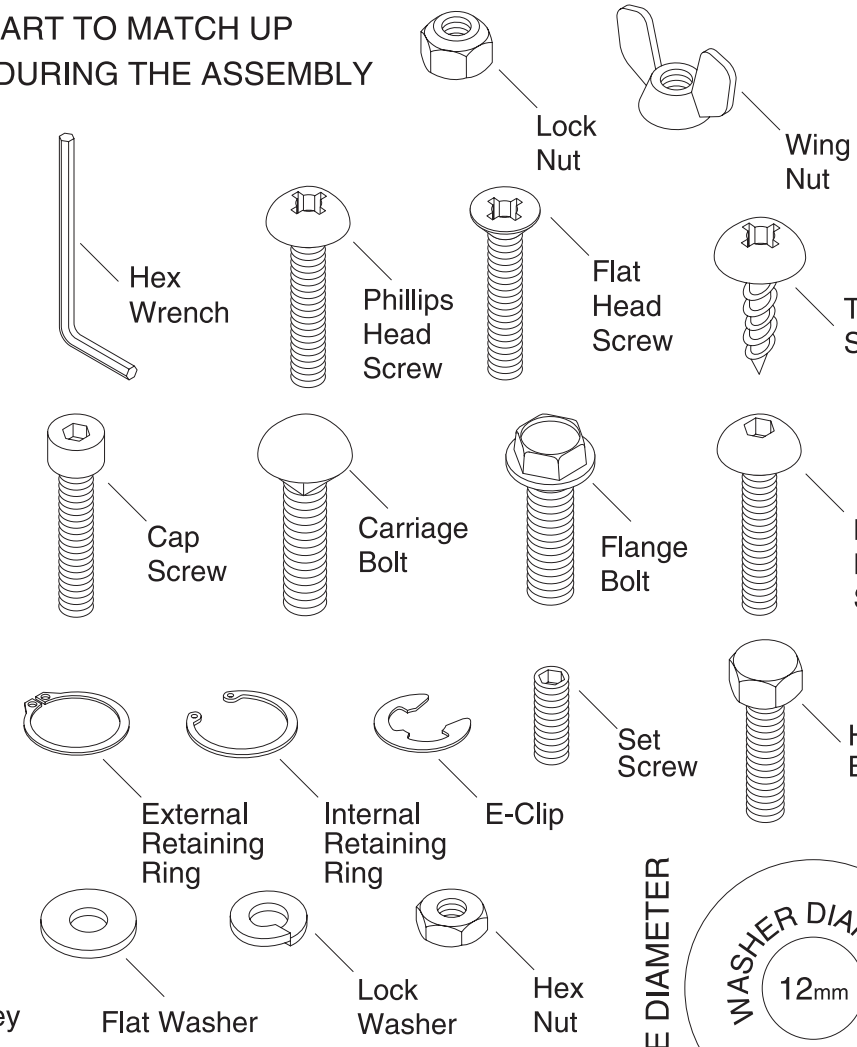

WASHERS ARE MEASURED BY THE INSIDE DIAMETER

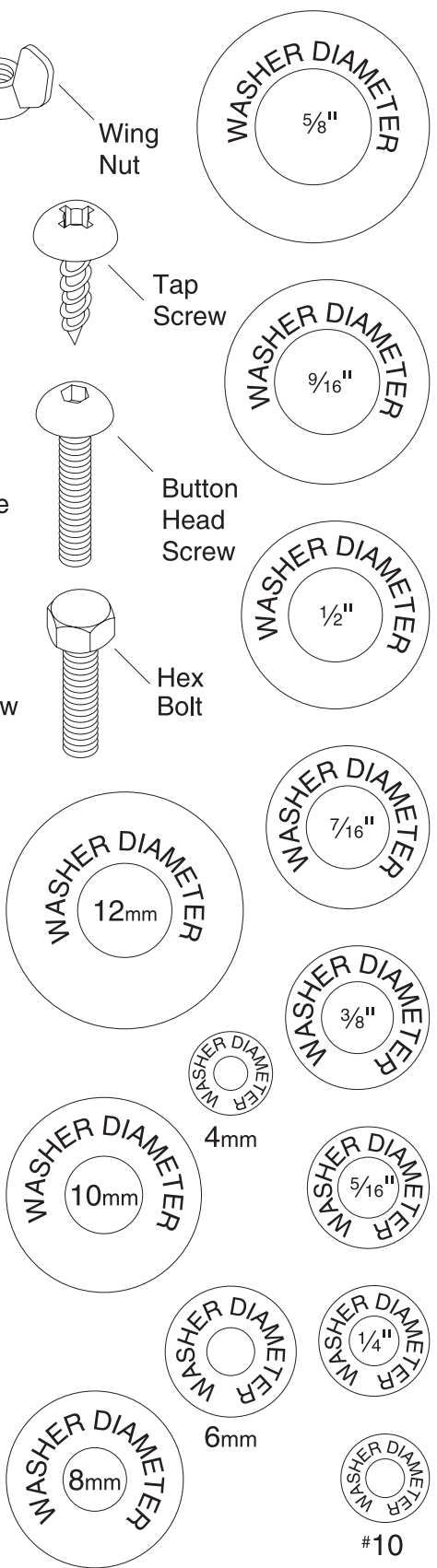

Cleanup

The unpainted surfaces of your machine are coated with a heavy-duty rust preventative that prevents corrosion during shipment and storage. This rust preventative works extremely well, but it will take a little time to clean.

Be patient and do a thorough job cleaning your machine. The time you spend doing this now will give you a better appreciation for the proper care of your machine's unpainted surfaces.

There are many ways to remove this rust preventative, but the following steps work well in a wide variety of situations. Always follow the manufacturer's instructions with any cleaning product you use and make sure you work in a well-ventilated area to minimize exposure to toxic fumes.

Before cleaning, gather the following:

- Disposable rags
- Cleaner/degreaser (WD-40 works well)
- Safety glasses & disposable gloves
- Plastic paint scraper (optional)

Basic steps for removing rust preventative:

1. Put on safety glasses.
2. Coat the rust preventative with a liberal amount of cleaner/degreaser, then let it soak for 5–10 minutes.
3. Wipe off the surfaces. If your cleaner/degreaser is effective, the rust preventative will wipe off easily. If you have a plastic paint scraper, scrape off as much as you can first, then wipe off the rest with the rag.
4. Repeat **Steps 2–3** as necessary until clean, then coat all unpainted surfaces with a quality metal protectant to prevent rust.

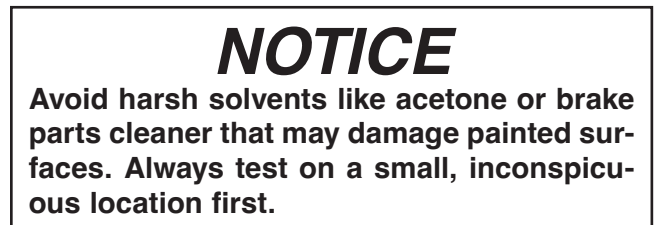
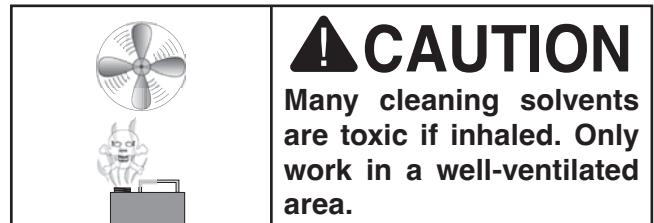
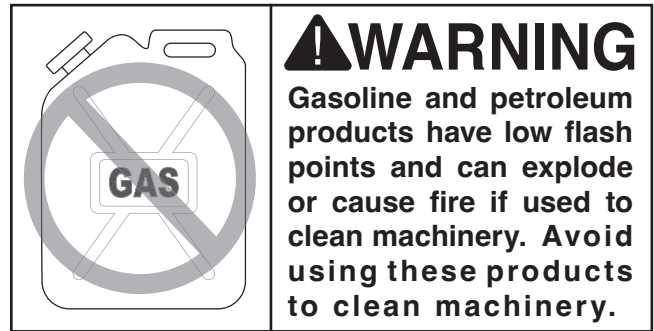

T23692—Orange Power Degreaser

A great product for removing the waxy shipping grease from the *non-painted* parts of the machine during clean up.



Figure 6. T23692 Orange Power Degreaser.



Site Considerations

Weight Load

Refer to the **Machine Data Sheet** for the weight of your machine. Make sure that the surface upon which the machine is placed will bear the weight of the machine, additional equipment that may be installed on the machine, and the heaviest workpiece that will be used. Additionally, consider the weight of the operator and any dynamic loading that may occur when operating the machine.

Space Allocation

Consider the largest size of workpiece that will be processed through this machine and provide enough space around the machine for adequate operator material handling or the installation of auxiliary equipment. With permanent installations, leave enough space around the machine to open or remove doors/covers as required by the maintenance and service described in this manual. **See below for required space allocation.**

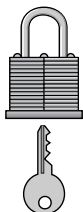
	<p>⚠ CAUTION Children or untrained people may be seriously injured by this machine. Only install in an access restricted location.</p>
---	---

Physical Environment

The physical environment where the machine is operated is important for safe operation and longevity of machine components. For best results, operate this machine in a dry environment that is free from excessive moisture, hazardous chemicals, airborne abrasives, or extreme conditions. Extreme conditions for this type of machinery are generally those where the ambient temperature range exceeds 41°–104°F; the relative humidity range exceeds 20%–95% (non-condensing); or the environment is subject to vibration, shocks, or bumps.

Electrical Installation

Place this machine near an existing power source. Make sure all power cords are protected from traffic, material handling, moisture, chemicals, or other hazards. Make sure to leave enough space around machine to disconnect power supply or apply a lockout/tagout device, if required.

Lighting

Lighting around the machine must be adequate enough that operations can be performed safely. Shadows, glare, or strobe effects that may distract or impede the operator must be eliminated.

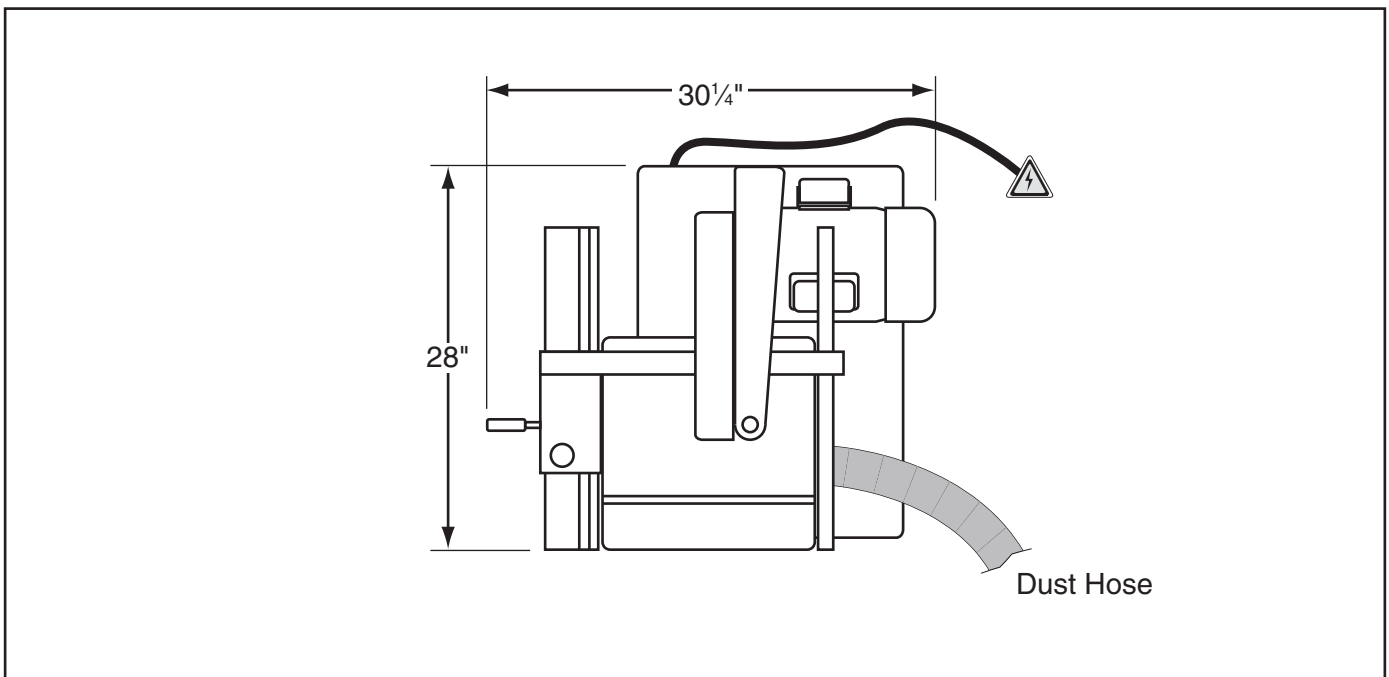

Figure 7. Minimum working clearances.



Assembly

The machine must be fully assembled before it can be operated. Before beginning the assembly process, refer to **Needed for Setup** and gather all listed items. To ensure the assembly process goes smoothly, first clean any parts that are covered or coated in heavy-duty rust preventative (if applicable).

To assemble machine:

1. Lay one stand side flat on a protective surface, then attach the upper and lower stand braces, as shown in **Figure 8**, with (8) M6-1 x 16 hex bolts, (8) 6mm flat washers, and (8) M6-1 flange nuts.

Note: Only hand-tighten the stand fasteners for now during these initial steps. Once the stand is fully assembled you will be instructed to fully tighten all fasteners.

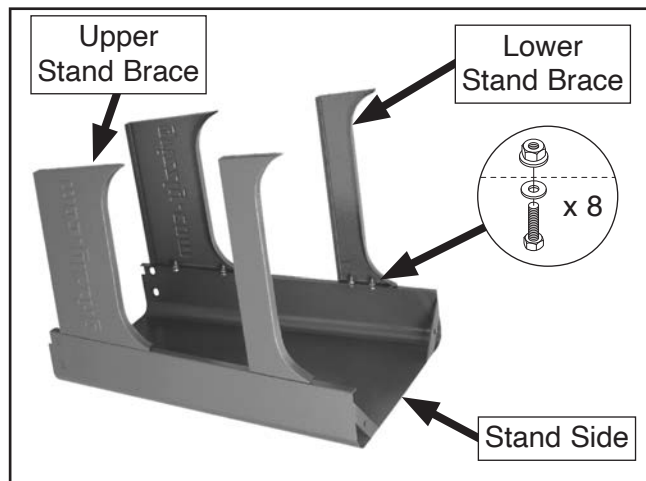

Figure 8. Upper and lower stand braces attached to the stand side.

2. Attach the remaining stand side to the assembly, as shown in **Figure 9**, with (8) M6-1 x 16 hex bolts, (8) 6mm flat washers, and (8) M6-1 flange nuts.



Figure 9. Second stand side attached.

3. Install the foot assemblies into the holes in the bottom of the stand assembly, using (2) $\frac{3}{8}$ "-16 hex nuts and (2) 10mm flat washers, as shown in **Figure 10**.

Note: Adjust the feet so that they are approximately the same height—this will make leveling the stand easier in a later step.

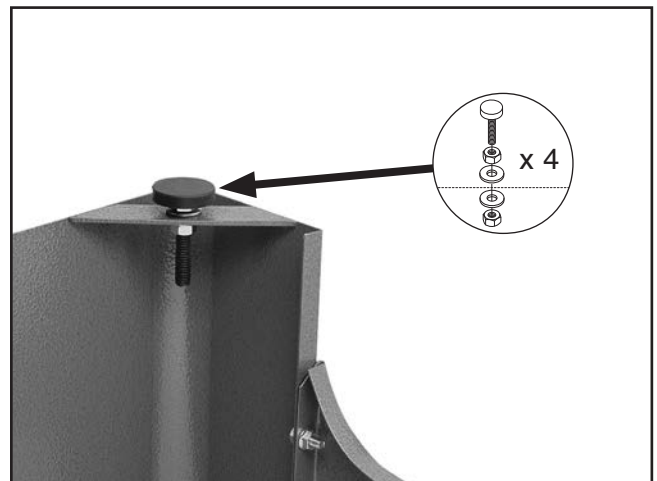

Figure 10. Stand foot installed (1 of 4).



- Turn the stand assembly upright and attach the top, as shown in **Figure 11**, with (8) M8-1.25 x 16 carriage bolts and (8) M8-1.25 flange nuts.

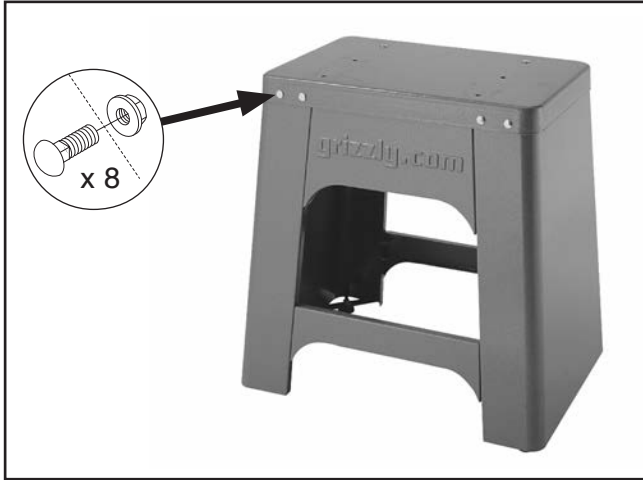

Figure 11. Stand top attached.

- Square up the stand components and fully tighten all the fasteners.
- Place the level on top of the stand assembly, as shown in **Figure 12**, then adjust the feet up or down to make the stand top level from side to side and front to back. Make sure that both hex nuts on the feet are tight against the stand assembly.



Figure 12. Leveling the stand.

- With the help of other people, lift the bandsaw assembly onto the stand and align the mounting holes.
- Secure the bandsaw assembly to the stand with (4) M8-1.25 x 35 hex bolts, (8) 8mm flat washers, (4) 8mm lock washers, and (4) M8-1.25 hex nuts, as shown in **Figure 13**.

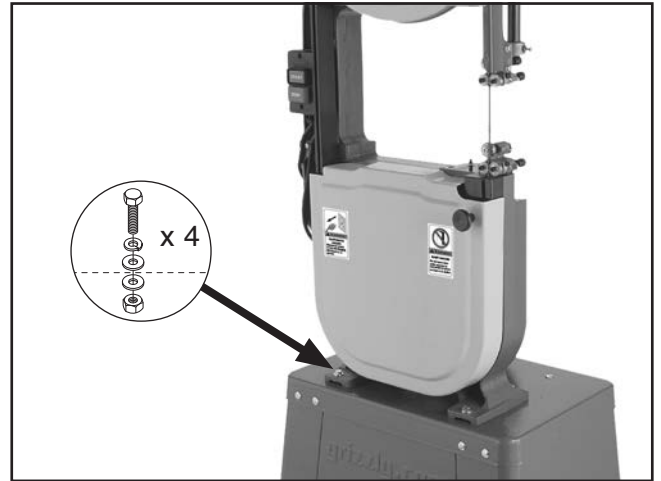

Figure 13. Bandsaw assembly attached to the stand.

- Position the table trunnion on the bandsaw, as shown in **Figure 14**, then secure it with the (2) M8-1.25 x 30 hex bolts and (2) 8mm lock washers.

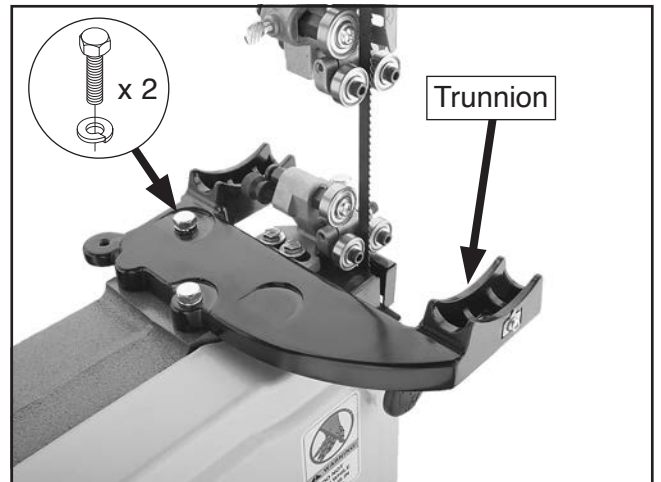

Figure 14. Trunnion installed.



10. Thread the remaining M8-1.25 hex nut onto the M8-1.25 x 80 positive stop hex bolt, then thread the bolt into the trunnion so that approximately 2" protrudes above the trunnion (see **Figure 15**). This will allow the table to rest approximately level when it is installed during the following steps.

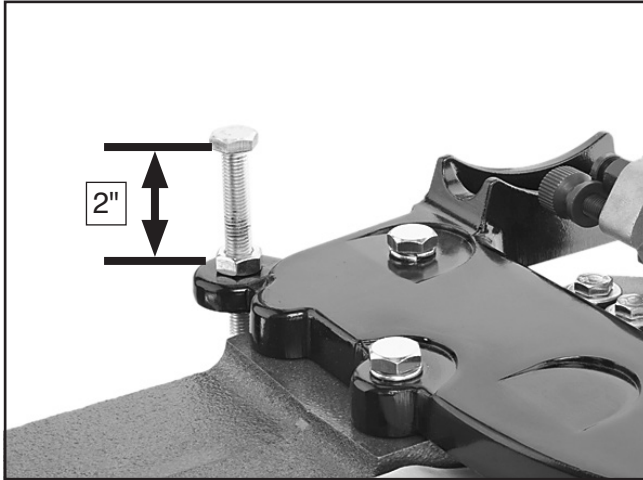

Figure 15. Positive stop installed.

11. Remove the aluminum table insert from the center of the table and remove the table pin from the end of the table slot (see **Figure 16**).

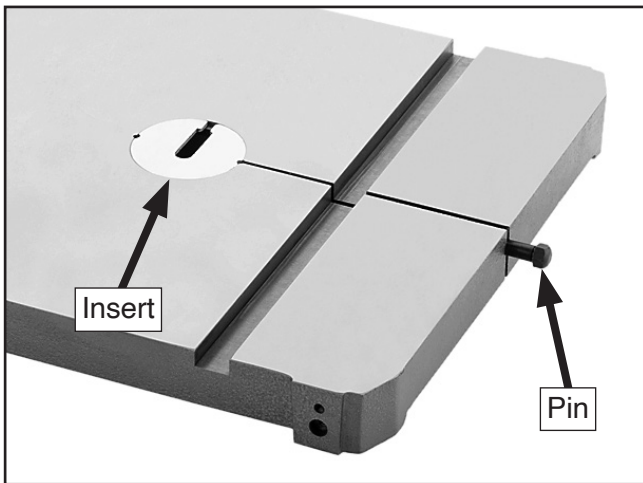

Figure 16. Table insert and pin.

12. Line up the blade with the table slot and move the table around the blade until the blade is in the center of the table, then turn the table 90° counterclockwise and rest it on the trunnions so that the bolts protrude from the bottom of the trunnions.
13. Secure the table by threading the (2) 3/8"-16 table lock knobs onto the bolts, as shown in **Figure 17**.



Figure 17. Securing table to the trunnion.

14. Replace the table insert and pin removed in **Step 11**. Make sure the table insert sits flush with the table surface.



15. Attach the front fence rail to the table with the (2) M6-1 x 20 hex bolts, (2) 6mm lock washers, and (2) 6mm flat washers (see **Figure 18**).

Note: *There is a small amount of vertical play in the rail holes. Make sure to position the rail evenly along its length before tightening the hex bolts. This will allow the fence to ride across the table with the proper amount of clearance.*

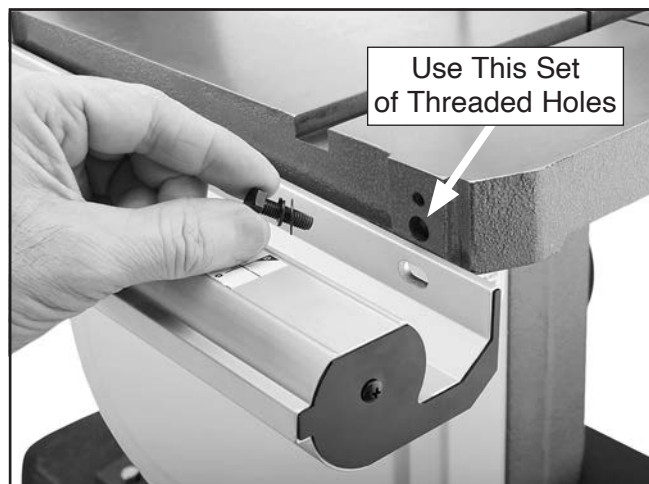

Figure 18. Attaching the front fence rail.

16. Attach the rear fence rail to the table with the (2) black M6-1 x 16 cap screws (see **Figure 19**).



Figure 19. Attaching the rear fence rail.

17. Thread (1) M8-1.25 hex nut onto the fence lock handle, then thread the handle into the fence and secure it in place by tightening the hex nut against the fence.
18. Move the fence lock handle up, position the fence face between the column and the blade, as shown in **Figure 20**, then place it onto the front fence rail.



Figure 20. Placing the fence onto the rails.

19. Thread the M6-1 hex nut onto the fence stand-off, then thread it into the rear underside of the fence (see **Figure 21**) so that the fence rests the same height above the table along its full length. Tighten the hex nut against the fence to secure the setting.

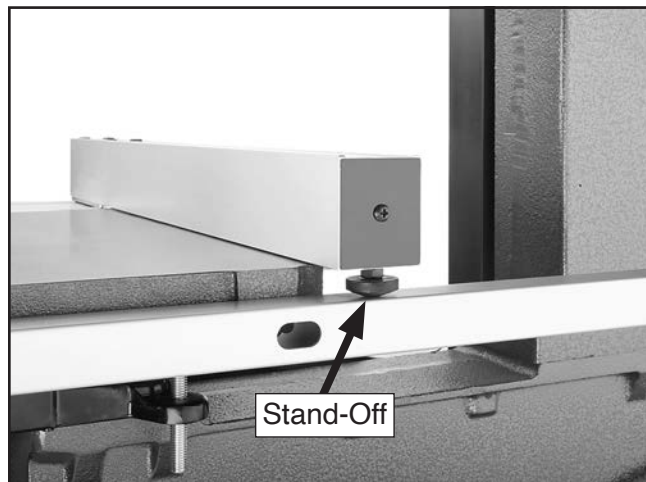

Figure 21. Fence stand-off installed.



Blade Center Tracking

Blade tracking is affected by the tilt of the upper wheel (known as center tracking) and the alignment of both wheels (known as coplanar tracking).

The wheels on this bandsaw were aligned at the factory, so center tracking is the only adjustment that needs to be performed when the saw is new (refer to the **Wheel Alignment** on **Page 47** for detailed instructions on coplanar tracking).

Note: *Changes in the blade tension may change the blade tracking. For best performance, regularly check and maintain the proper blade tracking.*

To center track blade:

1. DISCONNECT MACHINE FROM POWER!
2. Adjust the upper and lower blade guides away from the blade (refer to **Adjusting Blade Guide Bearings** later in this manual for detailed instructions).

Note: *When adjusting the blade tracking, the blade must have a reasonable amount of tension to simulate operating conditions. After the **Test Run** is successfully completed, you will perform a thorough version of the following steps to correctly tension the blade.*
3. Move the quick release lever up to the vertical position (see the following figure), then use the blade tension adjustment knob to bring the red marker to the correct mark on the tension scale for the blade installed.

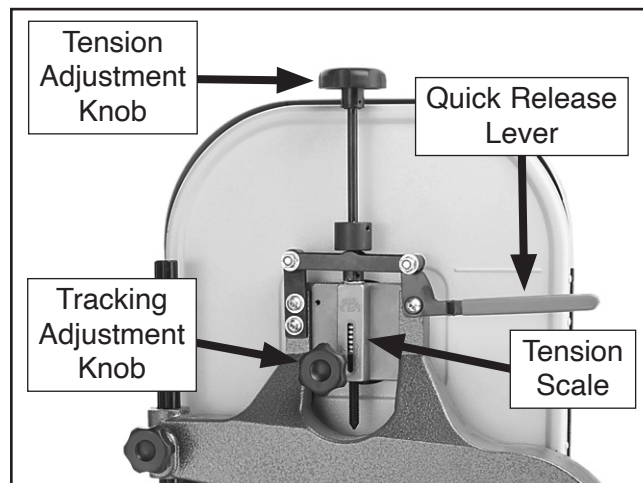

Figure 22. Blade tension and center tracking controls.

4. To tension the blade, pull the tension quick release lever down to the horizontal position.
5. Open the upper wheel cover, then spin the upper wheel by hand at least three times and watch how the blade rides on the crown of the wheel. Refer to the figure below for an illustration of this concept.
 - **If the blade rides on the center of the crown**, then the bandsaw is already tracked properly and no additional adjustments are needed. Skip to **Step 9**.
 - **If the blade does not ride on the center of the crown**, then continue with the next step.

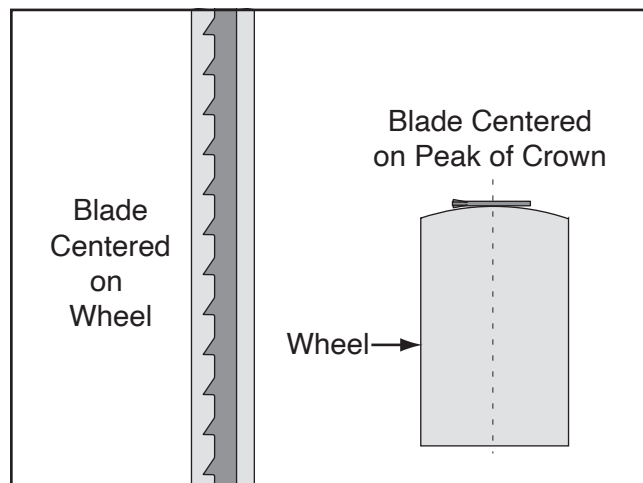

Figure 23. Profiles of blade properly center tracking.



6. Unlock the blade tracking adjustment knob so the knob will rotate for adjustments in the next steps.

Note: *The blade tracking adjustment knob controls the tilt of the upper wheel which, in turn, controls the center tracking of the blade.*

7. Spin the upper wheel with one hand and use the blade tracking adjustment knob with the other hand to make the blade ride in the center of the bandsaw wheel tire.
8. After the blade consistently rides in the center of the wheel after several rotations, lock the blade tracking adjustment knob to secure the setting.
9. Close the upper wheel cover.

Note: *For the best performance from your saw, regularly maintain the proper tracking of the blade.*

Dust Collection

! CAUTION

This machine creates a lot of wood chips/dust during operation. Breathing airborne dust on a regular basis can result in permanent respiratory illness. Reduce your risk by wearing a respirator and capturing the dust with a dust-collection system.

Recommended CFM at Dust Port: 400 CFM

Do not confuse this CFM recommendation with the rating of the dust collector. To determine the CFM at the dust port, you must consider these variables: (1) CFM rating of the dust collector, (2) hose type and length between the dust collector and the machine, (3) number of branches or wyes, and (4) amount of other open lines throughout the system. Explaining how to calculate these variables is beyond the scope of this manual. Consult an expert or purchase a good dust collection "how-to" book.

To connect a dust collection hose:

1. Fit the dust hose over the dust port, as shown in the figure below, and secure in place with a hose clamp.
2. Tug the hose to make sure it does not come off.

Note: *A tight fit is necessary for proper performance.*

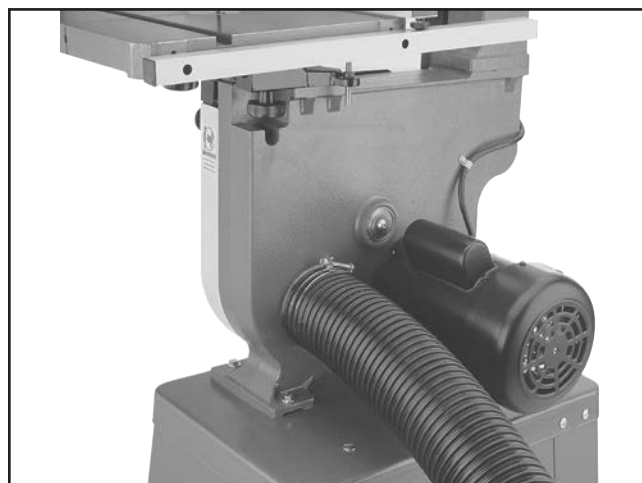

Figure 24. 4" dust hose attached to dust port.



Test Run

Once assembly is complete, test run the machine to ensure it is properly connected to power and safety components are functioning correctly.

If you find an unusual problem during the test run, immediately stop the machine, disconnect it from power, and fix the problem BEFORE operating the machine again. The **Troubleshooting** table in the **SERVICE** section of this manual can help.

The Test Run consists of verifying the following:
1) The motor powers up and runs correctly, and
2) the switch disabling padlock disables the switch properly.

!WARNING

Serious injury or death can result from using this machine BEFORE understanding its controls and related safety information. DO NOT operate, or allow others to operate, machine until the information is understood.

!WARNING

DO NOT start machine until all preceding setup instructions have been performed. Operating an improperly set up machine may result in malfunction or unexpected results that can lead to serious injury, death, or machine/property damage.

To test run machine:

1. Clear all setup tools away from machine.
2. Connect machine to power supply.
3. Turn machine **ON**, verify motor operation, and then turn machine **OFF**.

The motor should run smoothly and without unusual problems or noises.

4. Turn machine **OFF**.
5. Insert a switch disabling padlock (sold separately) through green ON button, as shown in **Figure 25**.

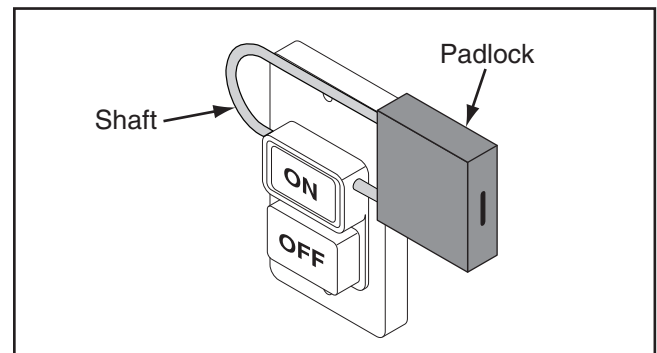

Figure 25. Switch disabling padlock inserted into ON button.

6. Press green ON button to test disabling feature on switch.
 - If machine does not start, switch disabling feature is working as designed.
 - If machine starts, immediately stop. The switch disabling feature is not working correctly. This safety feature must work properly before proceeding with regular operations. Call Tech Support for help.



Tensioning Blade

A properly tensioned blade is essential for making accurate cuts, extending the life of the blade, and making many other bandsaw adjustments.

Note: Before you performed the **Test Run**, you tensioned the blade according to the blade tension scale, which is only an approximate tension. The following procedure fine tunes the blade tension to ensure more accurate cutting results.

To tension the bandsaw blade:

1. Make sure the blade is properly center tracking as instructed in the **Blade Center Tracking** subsection previous to the **Test Run**.
2. To tension the blade, pull the tension quick release lever down to the horizontal position.

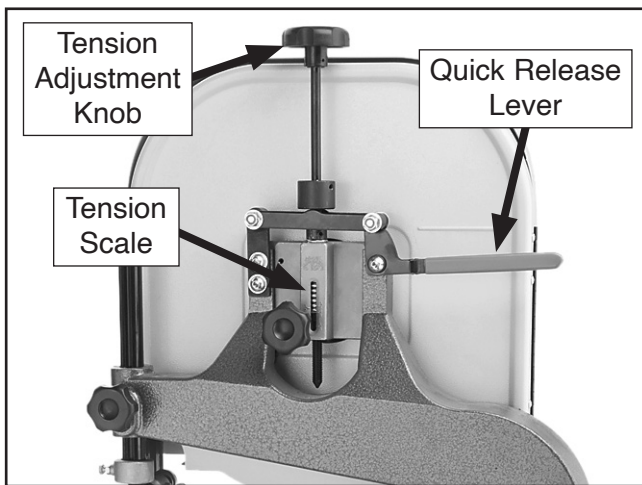

Figure 26. Blade tension controls.

3. Turn the bandsaw **ON**.
4. Slowly rotate the blade tension adjustment knob counterclockwise one quarter of a turn at a time—this will release blade tension. When you see the blade start to flutter, stop decreasing tension.

Now, slowly rotate the knob clockwise to increase the tension until the blade stops fluttering, then tighten the blade tension adjustment knob one more quarter of a turn.

5. Look at what the tension gauge reads and use that as a guide for tensioning that blade in the future.

Note: Do not rely on this setting for long periods of time because the blade will stretch with use.

Additionally, with extended use, the blade tensioning system may need to be reset for correct operation. Refer to the **Resetting Blade Tensioner** in the **Service** section on this manual.

NOTICE

When using a 3/4" blade, the blade tensioning system may need to be reset for correct operation. Refer to *Blade Tensioner* on Page 51 for detailed instructions.

Adjusting Blade Support Bearings

The support bearings are positioned behind the blade to prevent it from deflecting backward during cutting operations. Proper adjustment of the support bearings is an important part of making accurate cuts and keeps the blade teeth from coming in contact with the blade guides while cutting.

There are support bearings on the upper and lower blade guide assemblies. Both adjust in the same manner.

NOTICE

Whenever changing a blade or adjusting tension and tracking, the upper and lower support bearings and blade guides must be re-adjusted before cutting operations.



Tool Needed	Qty
Wrench 10mm	1

To adjust the support bearings:

1. Make sure the blade is tracking properly and is correctly tensioned.
2. DISCONNECT MACHINE FROM POWER!
3. Familiarize yourself with the support bearing controls shown in the figure below.

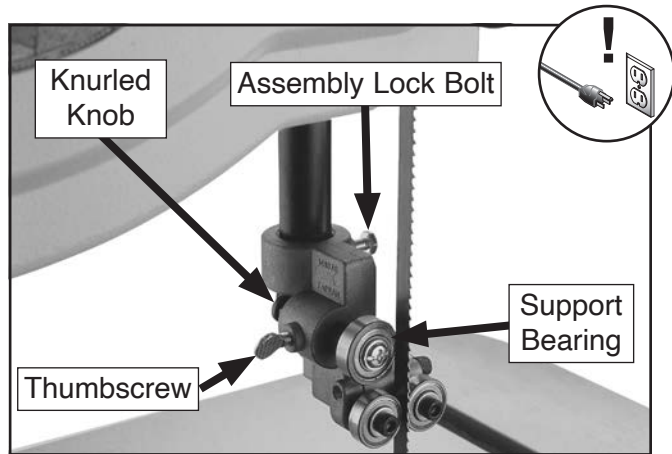

Figure 27. Support bearing controls.

4. Loosen the guide assembly lock bolt so that the support bearing can be rotated perpendicular to the blade in the next step.
5. Rotate the blade guide assembly until the face of the support bearing is perpendicular to the blade, as illustrated in the figure below.

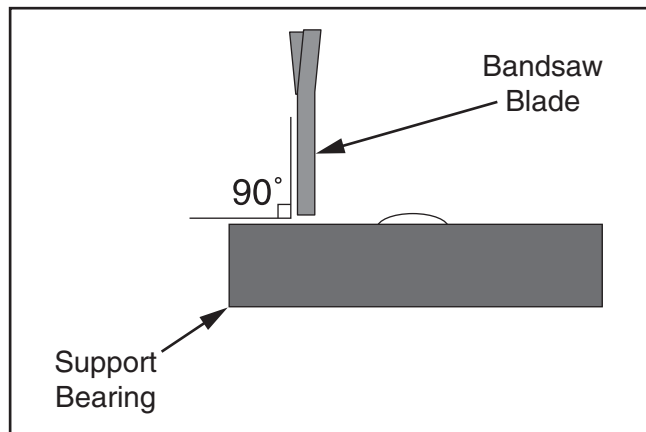

Figure 28. The face of the support bearing must be perpendicular (90°) to the blade.

6. Tighten the guide assembly lock bolt to secure the setting.
7. Loosen the thumbscrew on the support bearing adjustment shaft.
8. Use the knurled knob to position the support bearing approximately 0.016" behind the blade, as illustrated in the figure below.

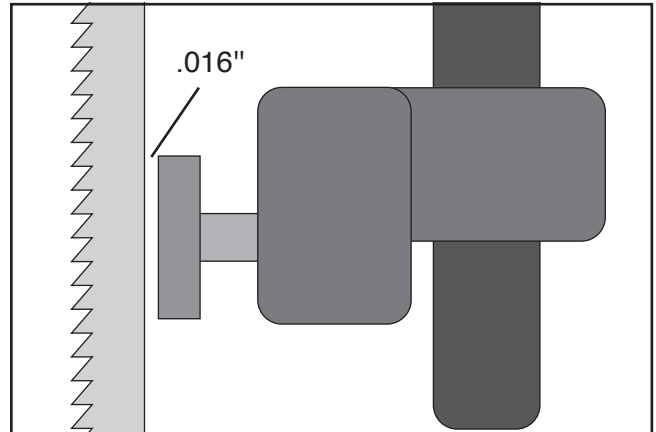

Figure 29. The face of the support blade must be approximately 0.016" behind the blade.

Tip: To quickly gauge this setting, fold a crisp dollar bill in half twice (when folded tightly, four thicknesses of a dollar bill is approximately 0.016"). Place the folded dollar bill between the support bearing and the blade, as shown in the figure below.



Figure 30. Dollar bill folded twice to make a quick 0.016" gauge.

9. Tighten the thumbscrew to lock the support bearing in place.



Adjusting Blade Guide Bearings

Properly adjusting the blade guides provides side-to-side support to help keep the blade straight while cutting, which is essential to making accurate cuts.

Tool Needed	Qty
Hex Wrench 4mm.....	2

To adjust the upper and lower blade guides:

1. Make sure that the blade is tracking properly and is correctly tensioned.
2. DISCONNECT MACHINE FROM POWER!
3. Familiarize yourself with the blade guide controls shown in the figure below.

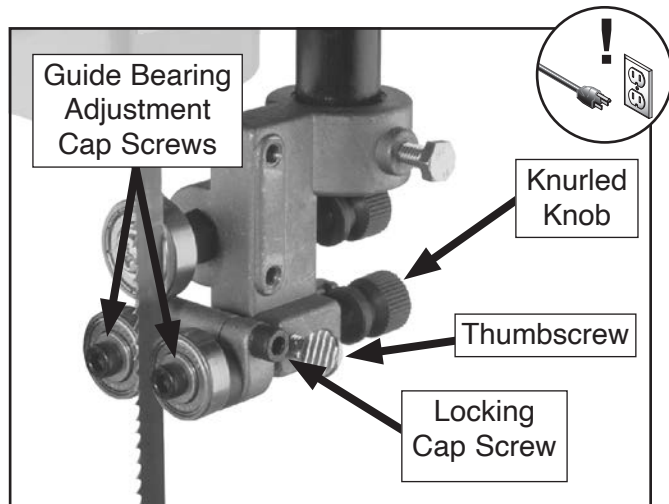

Figure 31. Blade guide bearing controls.

4. Loosen the thumbscrew shown in the figure above, then use the knurled knob to adjust the guide bearings laterally so that the bearing faces are just behind the blade gullet, as illustrated in the following figure.

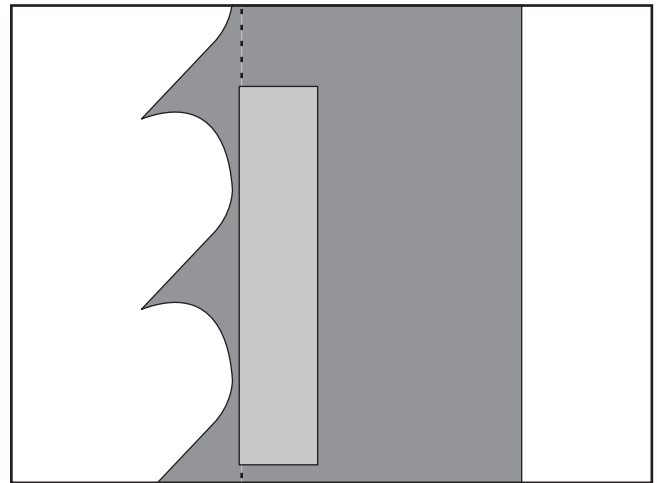

Figure 32. The blade guide bearings should be positioned just behind the blade gullets.

Note: With wider blades, it may not be possible to bring the guide bearings just behind the blade gullets. In that case, position them as far forward as possible without allowing the guide bearing housing to touch the back of the blade.

NOTICE

To reduce the risk of damage to the blade or guide bearings, make sure that the bearings do not contact the blade teeth when the blade is deflected backward.

5. When you are satisfied with the lateral adjustment of the guide bearings, re-tighten the thumbscrew to secure the setting.



- Loosen both cap screws behind the guide bearings, then rotate the adjustment cap screws so the bearings evenly and lightly touch the sides of the blade (see the illustration in the following figure).

Note: When the blade guide bearings are properly adjusted against the blade, they should still be able to rotate.

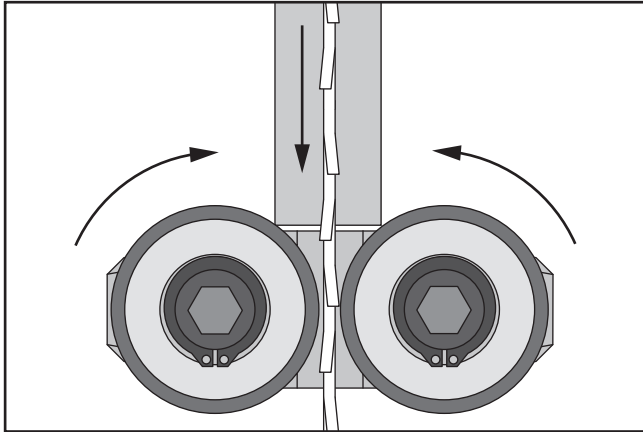

Figure 33. Blade guide bearings evenly and lightly touching the sides of the blade.

- While keeping the adjustment cap screws from turning with one hex wrench, re-tighten the locking cap screws to secure the settings.

NOTICE

Whenever changing a blade or adjusting the blade tension or tracking, the support and guide bearings must be re-adjusted before resuming operation.

Table Tilt Calibration

When properly adjusted, the positive stop bolt enables the table to be quickly returned perpendicular with the blade.

To tilt the table to the left, the positive stop bolt must be lowered from its correct height, then re-adjusted after the table is returned to 0°.

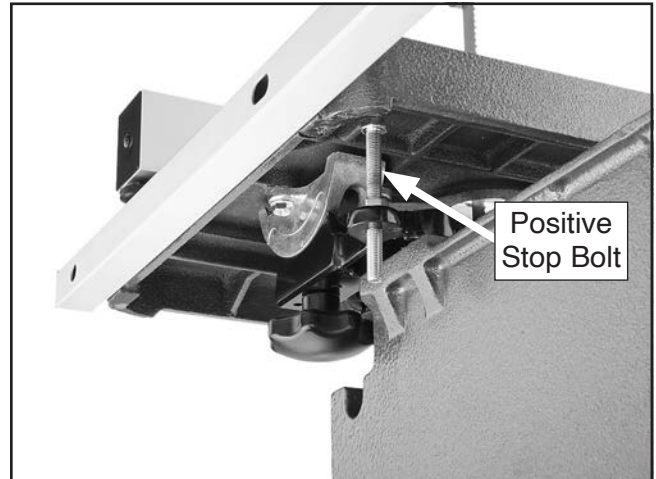

Figure 34. Positive stop bolt set at 90° (viewed from behind the table).

Tools Needed	Qty
Wrench 13mm	1
Phillips Screwdriver #2	1
Machinist's Square	1

To set the positive stop 90° to the blade:

- Make sure the blade is correctly tensioned as described in the **Tensioning Blade** subsection earlier in this manual.
- DISCONNECT MACHINE FROM POWER!**
- Loosen the two table lock knobs that secure the table to the trunnions.
- Loosen the hex nut that locks the positive stop bolt in place.



5. Completely raise the upper blade guide assembly, then place the machinist's square flat on the table and against the side of the blade, as illustrated in the figure below.

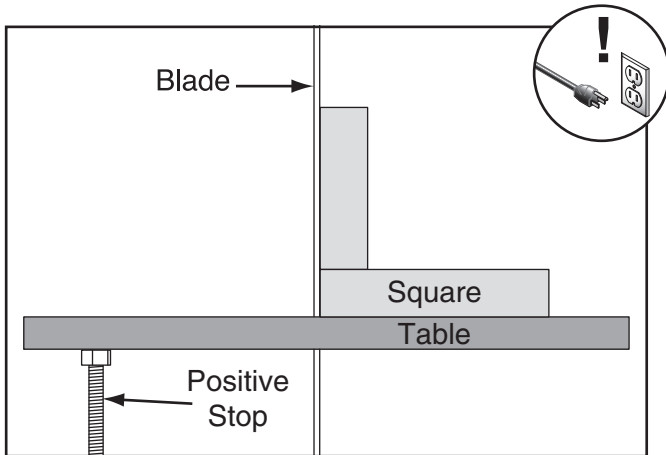

Figure 35. Using a square to adjust the table perpendicular to the side of the blade.

6. Raise or lower the positive stop bolt until the table is perpendicular to the side of the blade, then re-tighten the hex nut against the casting to secure the setting.
7. Rest the table on the positive stop bolt, then re-tighten the table lock knobs to secure the table perpendicular to the side of the blade.
8. Observe the position of the table tilt pointer on the tilt scale located underneath the front of the table (see the figure below).

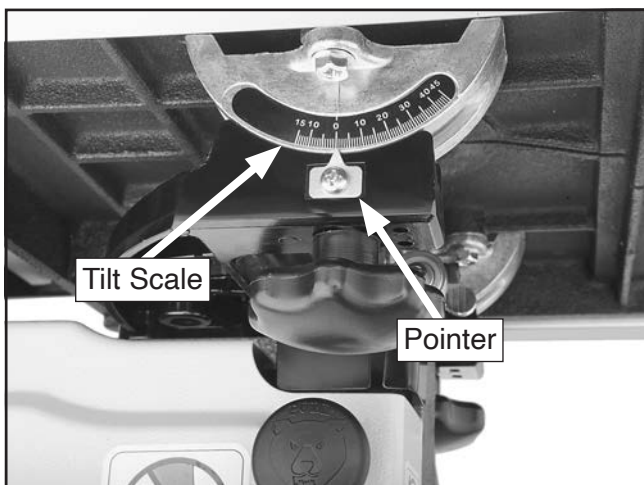

Figure 36. Location of the table tilt scale.

9. If the pointer is not correctly positioned at the 0° mark, then loosen the pointer screw, position the pointer at the 0° mark, and re-tighten the screw to hold it in place.

Aligning Table

To ensure cutting accuracy when the table is first installed, the table should be aligned so the miter slot is parallel to the bandsaw blade.

Tools Needed

	Qty
Straightedge 2'	1
Fine Ruler	1
Masking Tape	As Needed
Wrench 10mm	1

To align the table to the blade:

1. Make sure the blade is correctly tensioned as described in the **Tensioning Blade** subsection earlier in this manual.
2. **DISCONNECT MACHINE FROM POWER!**
3. Make sure the table is perpendicular to the side of the blade and locked in place.
4. Place an accurate straightedge along the blade. The straightedge should lightly touch both the front and back of the blade (see **Figure 37**).

Note: Make sure the straightedge does not go across a tooth.

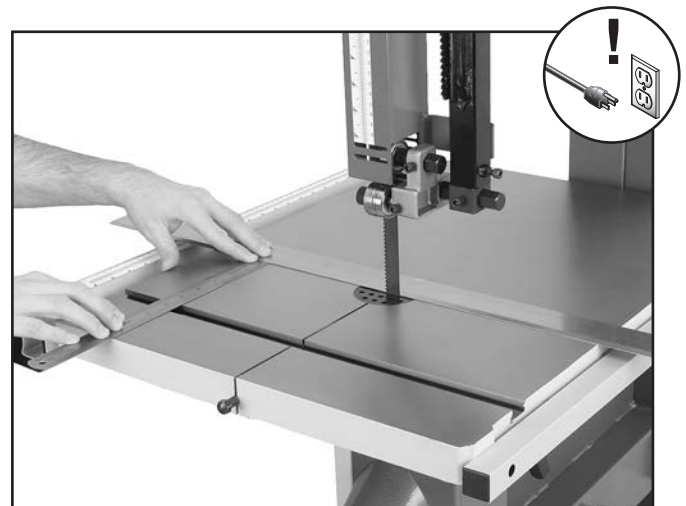

Figure 37. Measuring for table-to-blade parallelism.



5. Use the fine ruler to measure the distance from the straightedge and the miter slot along the full depth of the table.
 - If the distances are the same, no further adjustments are required.
 - If the distances are different, continue with **Step 6**.
6. Loosen the six flange bolts that secure the table to the trunnion brackets (see the figure below).

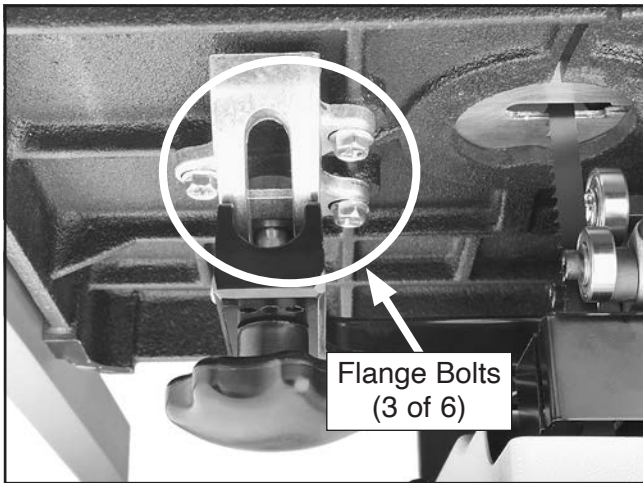

Figure 38. Location of trunnion bracket flange bolts.

7. Shift the table so that the distances are equal between the straightedge and miter slot along the full depth of the table.
8. Taking care not to move the table further, re-tighten the flange bolts.
9. Verify the setting and, if necessary, repeat this procedure until you are satisfied with the adjustment.

Aligning Fence

To ensure accurate cutting when using the fence, the face of the fence must be parallel to the table miter slot and, thus, to the side of the blade.

Tools Needed	Qty
Hex Wrench 5mm.....	1

To align the fence parallel with the miter slot:

1. Make sure the miter slot is parallel with the blade, as instructed in the previous **Aligning Table** procedure.
2. **DISCONNECT MACHINE FROM POWER!**
3. Install the fence on the right side of the blade, even with the edge of the miter slot, then lock it in place.
 - If the fence is parallel with the miter slot, no adjustment is necessary.
 - If the fence is not parallel with the miter slot, proceed to **Step 4**.
4. Loosen the four fence adjustment cap screws shown in the figure below, adjust the fence parallel to the miter slot, then re-tighten the cap screws to secure the setting.

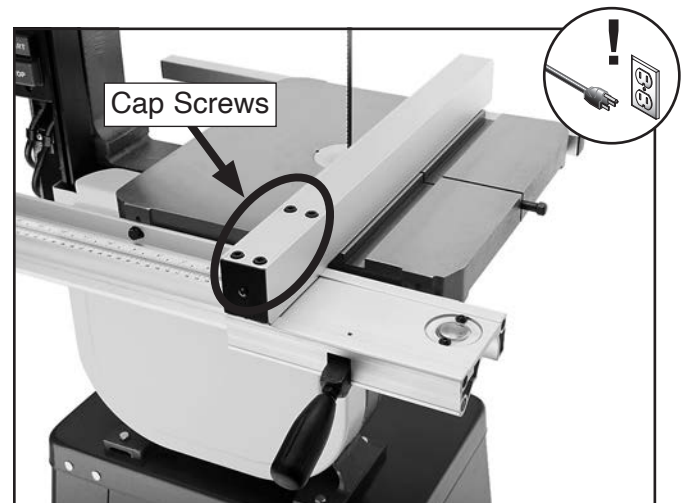

Figure 39. Location of the fence adjustment cap screws.



SECTION 4: OPERATIONS

Operation Overview

The purpose of this overview is to provide the novice machine operator with a basic understanding of how the machine is used during operation, so the machine controls/components discussed later in this manual are easier to understand.

Due to the generic nature of this overview, it is **not** intended to be an instructional guide. To learn more about specific operations, read this entire manual, seek additional training from experienced machine operators, and do additional research outside of this manual by reading "how-to" books, trade magazines, or websites.

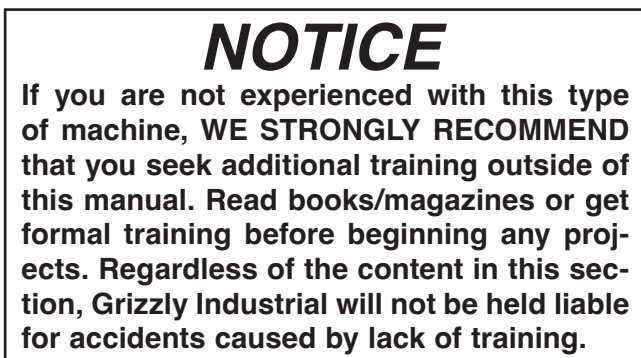
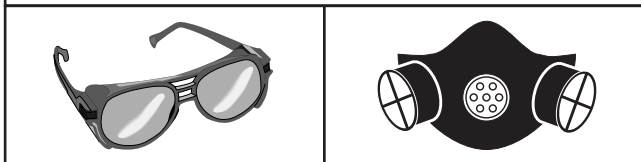

To complete a typical operation, the operator does the following:

1. Examines workpiece to make sure it is suitable for cutting.
2. Adjusts table tilt, if necessary, to correct angle of desired cut.
3. If using fence, adjusts it for width of cut and then locks it in place. If using miter gauge, adjusts angle and locks it in place.
4. Loosens guide post lock knob, adjusts the upper blade guide height to just clear workpiece (no more than 1/4"), then re-tightens guide post lock knob.
5. Checks to make sure workpiece can safely pass all the way through blade without interference from other objects.
6. Puts on safety glasses and a respirator.
7. Starts dust collector, then bandsaw.
8. Holds workpiece firmly and flatly against both table and fence (or miter gauge), and then pushes workpiece into blade at a steady and controlled rate until cut is complete.

The operator is very careful to keep fingers away from blade and uses a push stick to feed narrow workpieces.
9. Stops bandsaw, then dust collector.



Disabling & Locking Switch

The ON/OFF switch can be disabled and locked by inserting a padlock through the ON button, as shown. Locking the switch in this manner can prevent unauthorized operation of the machine, which is especially important if the machine is not stored inside an access-restricted building.

IMPORTANT: Locking the switch with a padlock only restricts its function. It is not a substitute for disconnecting power from the machine when adjusting or servicing.

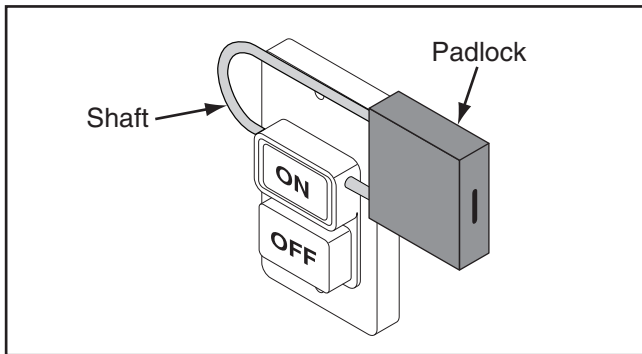

Figure 40. Switch disabled by a padlock (sold separately).

!WARNING

Children or untrained people can be seriously injured by this machine. This risk increases with unsupervised operation. To help prevent unsupervised operation, disable and lock the switch before leaving machine unattended! Place key in a well-hidden or secure location.

NOTICE

The padlock shaft diameter is important to the disabling function of the switch. With any padlock used to lock the switch, test the switch after installation to ensure that it is properly disabled.

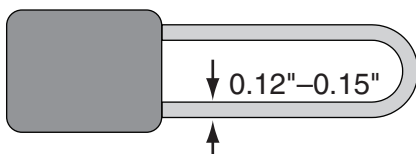

Workpiece Inspection

Some workpieces are not safe to cut or may require modification before they are safe to cut.

Before cutting, inspect all workpieces for the following:

- **Material Type:** This machine is intended for cutting natural and man-made wood products, laminate covered wood products, and some plastics. Cutting drywall or cementitious backer board creates extremely fine dust and may reduce the life of the bearings. This machine is NOT designed to cut metal, glass, stone, tile, etc.; cutting these materials with a table saw may lead to injury.
- **Foreign Objects:** Nails, staples, dirt, rocks and other foreign objects are often embedded in wood. While cutting, these objects can become dislodged and hit the operator, cause kickback, or break the blade, which might then fly apart. Always visually inspect your workpiece for these items. If they can't be removed, DO NOT cut the workpiece.
- **Large/Loose Knots:** Loose knots can become dislodged during the cutting operation. Large knots can cause kickback and machine damage. Choose workpieces that do not have large/loose knots or plan ahead to avoid cutting through them.
- **Wet or "Green" Stock:** Cutting wood with a moisture content over 20% causes unnecessary wear on the blades, increases the risk of kickback, and yields poor results.
- **Excessive Warping:** Workpieces with excessive cupping, bowing, or twisting are dangerous to cut because they are unstable and often unpredictable when being cut. DO NOT use workpieces with these characteristics!
- **Minor Warping:** Workpieces with slight cupping can be safely supported if the cupped side is facing the table or the fence. On the contrary, a workpiece supported on the bowed side will rock during a cut and could cause kickback or severe injury.

Guide Post

The guide post, shown in the figure below, connects the upper blade guide assembly and blade guard to the bandsaw.

The guidepost allows these components to be positioned above the workpiece at a distance that provides the greatest support to the blade and minimizes operator exposure to the blade. We recommend positioning the blade guides so that they just clear the workpiece.

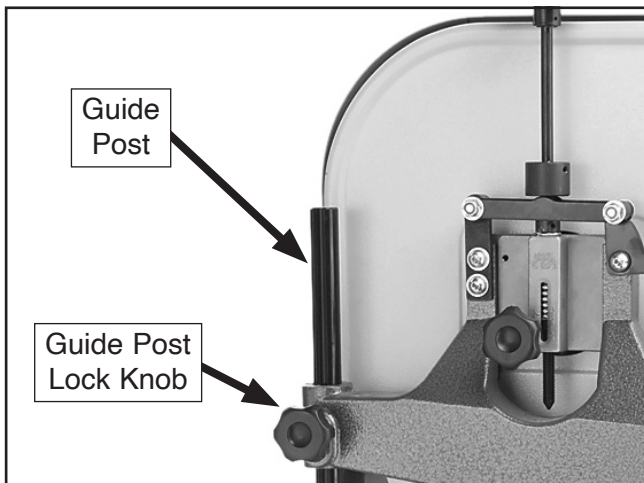

Figure 41. Guide post and lock knob.

To adjust the height of the guide post:

1. Make sure that the blade tension, blade tracking, support bearings, and blade guide bearings are adjusted correctly.
2. DISCONNECT MACHINE FROM POWER!
3. Loosen the guide post lock knob, then adjust the height of the guide post so that the blade guide assembly just clears the workpiece.
4. Re-tighten the lock knob to secure the setting.

Table Tilt

The table can be tilted when making angle or bevel cuts.

Note: *When tilting the table to the left, the positive stop bolt must be lowered. Be sure to re-adjust it when returning the table to be perpendicular with the blade.*

To tilt the table:

1. DISCONNECT MACHINE FROM POWER!
2. Loosen both table lock knobs underneath the table.
3. Use the table tilt scale underneath the front of the table or a protractor against the table and blade to tilt the table to the desired degree, then re-tighten the lock knobs.



Blade Speed

The Model G0555 offers blade speeds of 1690 and 2950 FPM. For general woodworking and most cutting operations, we recommend using the 2950 FPM speed. Keep in mind, the results from different speeds are related to the type of workpiece, the blade being used for the operation, and the feed rate.

Use the chart below as a general guide to blade speed:

Type of Cutting Operation	Blade Speed (FPM)
Most Species of Wood	2950
Super Dense Hardwood	1690
Fast/Average Feed Rate	2950
Requires Slow Feed Rate	1690
Rough Edges Acceptable	2950
Requires Smooth Edges	1690
Quick, Production Cuts	2950
Detailed, Intricate Cuts	1690

Speed changes are made by re-positioning the ribbed V-belt on the pulleys.

Tools Needed	Qty
Hex Wrench 6mm.....	1

To change the blade speed:

1. DISCONNECT MACHINE FROM POWER!
2. Open the lower wheel cover and loosen the motor mount adjustment and hinge cap screws shown in **Figure 42**.

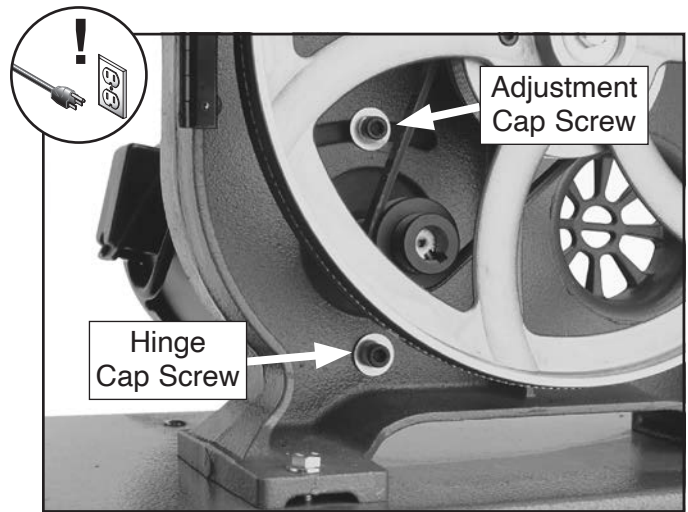

Figure 42. Locations of the motor adjustment and hinge cap screws.

3. Move the motor so that the adjustment cap screw slides to the right of the slot. This will release the tension on the ribbed V-belt.
4. Position the V-belt on the pulleys as illustrated in **Figure 43** for the desired speed.

Note: Make sure the ribs of the V-belt are well seated in the pulley grooves.

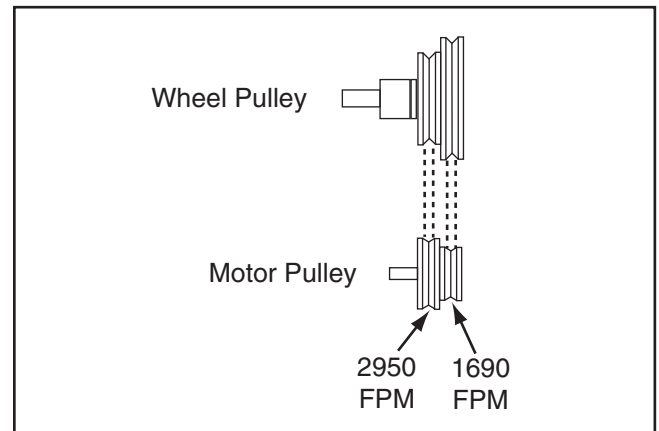

Figure 43. Drive belt position for the different speeds.

5. Move the motor so that the adjustment cap screw slides to the left of the slot.
6. Apply enough pressure on the motor so that there is approximately 1/4" deflection of the V-belt with moderate pressure from your finger between the pulleys, then re-tighten the adjustment and hinge cap screws.
7. Close the lower wheel cover before re-connecting the bandsaw to power.



Blade Information

Blade Dimensions

Length Range..... 92¹/₂"–93¹/₂"
 Width Range..... 1/₈"–3/₄"

Selecting the right blade requires a knowledge of the various blade characteristics to match the blade with the particular cutting operation.

Blade Length

Measured by the circumference, blade lengths are usually unique to the brand of your bandsaw and the distance between wheels. Refer to the **Accessories** section later in this manual for blade replacements from Grizzly.

Blade Width

Measured from the back of the blade to the tip of the blade tooth (the widest point), blade width is often the first consideration given to blade selection. Blade width dictates the largest and smallest curve that can be cut, as well as how accurately it can cut a straight line.

Always pick the size of blade that best suits your application.

- **Curve Cutting:** Use the chart in the figure below to determine the correct blade for curve cutting. Determine the smallest radius curve that will be cut on your workpiece and use the corresponding blade width.

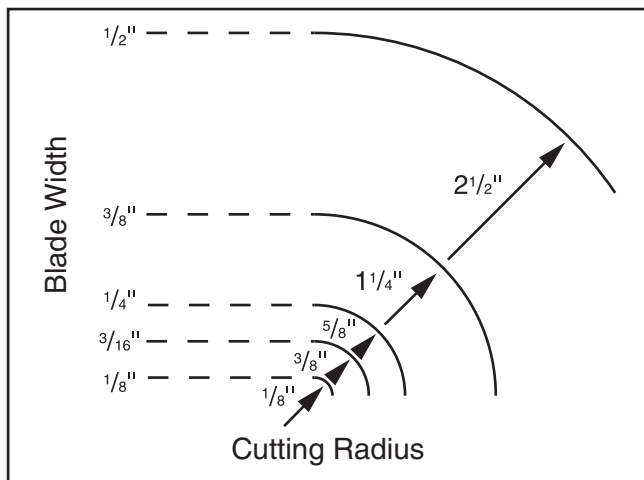

Figure 44. Recommended cutting radius per blade width.

- **Straight Cutting:** Use the largest width blade that you own. Large blades excel at cutting straight lines and are less prone to wander.

Tooth Style

The figure below illustrates the three main blade tooth styles:

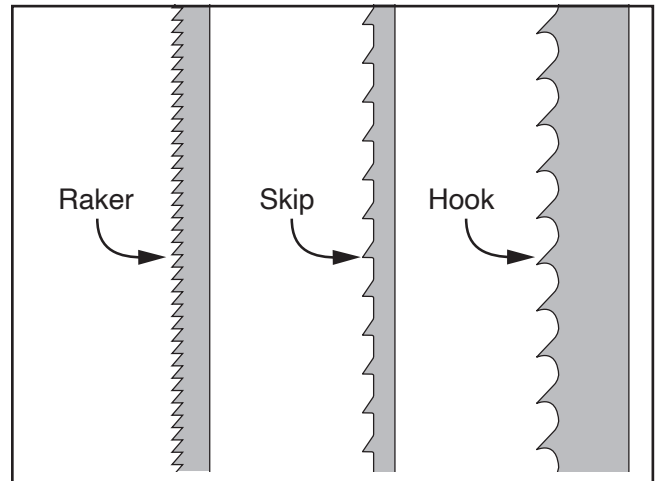

Figure 45. Main blade tooth styles.

- **Raker:** Considered to be the standard because the tooth size and shape are the same as the tooth gullet. The teeth on raker blades usually are very numerous, have no angle, and produce cuts by scraping the material. As a result, smooth cuts can be achieved without cutting fast or generating more heat than other tooth types.
- **Skip:** Similar to a raker blade that is missing every other tooth. Because of the design, skip toothed blades have a much larger gullet than raker blades, and therefore, cut faster and generate less heat. However, these blades also leave a rougher cut than raker blades.
- **Hook:** The teeth have a positive angle (downward) which makes them dig into the material, and the gullets are usually rounded for easier waste removal. These blades are excellent for the tough demands of resawing and ripping thick material.



Tooth Pitch

Measured as TPI (teeth per inch), tooth pitch determines the number of teeth. More teeth per inch (fine pitch) will cut slower, but smoother; while fewer teeth per inch (coarse pitch) will cut rougher, but faster. As a general rule, choose blades that will have at least three teeth in the material at all times. Use fine-pitched blades on harder woods and coarse-pitched blades on softer woods.

Blade Care

A bandsaw blade is a thin piece of steel that is subjected to tremendous stresses when cutting. You can obtain longer use from a bandsaw blade if you give it fair treatment and always use the appropriate feed rate for your operation. Be sure to select blades with the proper width, style, and pitch for each application. The wrong choice of blades will often produce unnecessary heat which will shorten the life of your blade.

A clean blade will perform much better than a dirty blade. Dirty or gummed up blades pass through the cutting material with much more resistance than clean blades. This extra resistance also causes unnecessary heat. Resin/pitch cleaners are excellent for cleaning dirty blades.

Blade Breakage

Many conditions may cause a bandsaw blade to break. Blade breakage is unavoidable, in some cases, since it is the natural result of the peculiar stresses that bandsaw blades are subjected to. Blade breakage is also due to avoidable circumstances. Avoidable breakage is most often the result of poor care or judgement on the part of the operator when mounting or adjusting the blade or blade guides.

The most common causes of blade breakage are:

- Faulty alignment/adjustment of the guides.
- Forcing/twisting a wide blade around a short radius.
- Feeding the workpiece too fast.
- Dull teeth or damaged tooth set.
- Over-tensioned blade.
- Upper blade guide assembly set too high above the workpiece.
- Using a blade with a lumpy or improperly finished braze or weld.
- Continuously running the bandsaw when not in use.
- Leaving blade tensioned when not in use.
- Using the wrong TPI for the workpiece thickness. (The general rule of thumb is three teeth in the workpiece at all times.)



Blade Change

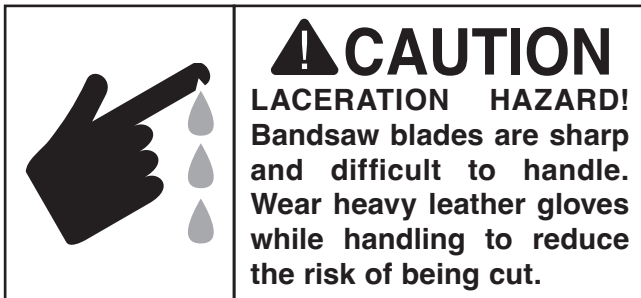
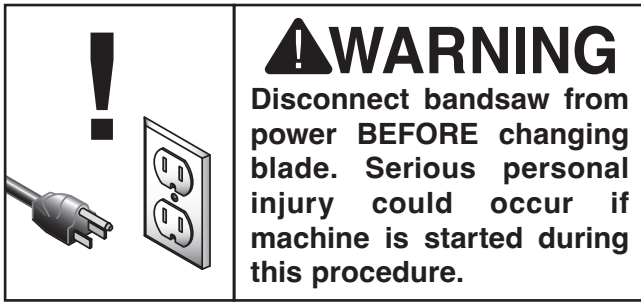

Blade Removal

1. DISCONNECT MACHINE FROM POWER!
2. Move the blade tension quick release lever up to release blade tension.
3. Adjust the upper blade guide assembly all the way up and move the blade guides completely away from the blade.
4. Remove the fence and miter gauge from the table, then remove the table insert and the table pin.
5. Open the upper and lower wheel covers.
6. Put on heavy leather gloves, then slip the blade off the wheels, rotate it 90°, and slide it through the table slot and off the machine.

Blade Installation

1. DISCONNECT MACHINE FROM POWER!
2. Perform **Steps 2–6** in the previous **Blade Removal** procedure.
3. Put on heavy leather gloves, position the blade so that the teeth are facing to the right and down toward the table, then slide it through the table slot.

Note: *If the teeth will not point downward in any orientation, the blade is inside-out. Remove the blade and twist it right side-out.*

4. Rotate the blade 90°, then slip it over the wheels while making sure it is properly positioned between the blade guards and guides.
5. Use the blade tension adjustment knob to bring the red marker to the correct blade width mark on the tension scale, then pull the blade tension quick release lever down to the horizontal position.

— If you are having difficulty pulling the quick release lever down or the blade is a different length from the previous blade, adjust the blade tensioner as instructed in the **Blade Tensioner** subsection on **Page 51**. Then, continue with **Step 6**.

— If you successfully pull the quick release lever down and the blade is properly tensioned, continue with **Step 6**.

6. Check and adjust the blade tracking.
7. Adjust the support bearings and the upper/lower blade guides.
8. Close the wheel covers, and replace the table insert and table pin.



Basic Cutting Tips

Here are some basic tips to follow when operating the bandsaw:

- Replace, sharpen, and clean blades as necessary. Make adjustments periodically to keep the saw running in top condition.
- Use light and even pressure while cutting. Light contact with the blade eases line following and prevents undue friction.
- Avoid twisting the blade when cutting around tight corners. Allow the blade to saw around the corners.
- Misusing the saw or using incorrect techniques is unsafe and results in poor cuts. Remember—the blade does the cutting with the operator's guidance.

Cutting Options

The bandsaw is capable of performing the following cuts:

- Miters
- Angles
- Resaw
- Ripping
- Crosscutting
- Compound Angles
- Complex Curves
- Duplicate Parts
- Circles
- Beveled Curves

Ripping

"Ripping" means cutting with the grain of the wood stock. For plywood and other processed wood, ripping simply means cutting down the length of the workpiece. Beveled rip cuts may be performed by tilting the table.

To make a rip cut:

1. Adjust fence to match width of cut on your workpiece, then lock fence in place.
2. Adjust blade guide assembly to proper height above workpiece.
3. After all safety precautions have been met, turn bandsaw **ON** and wait for it to come to full speed. Slowly feed workpiece into blade until blade is completely through workpiece. The figure below shows an example of a ripping operation.

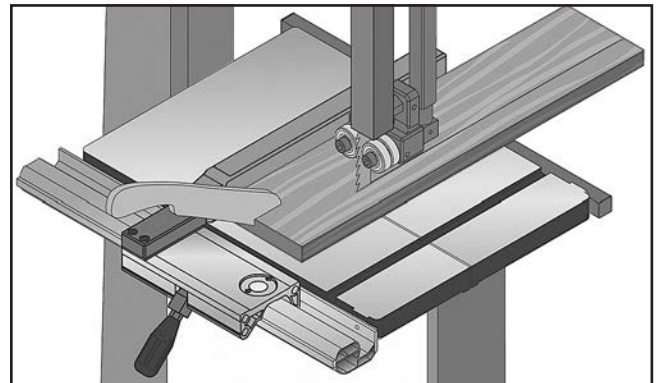

Figure 46. Example of a ripping operation.

!WARNING

ALWAYS use a push stick when ripping narrow pieces. Failure to follow these warnings may result in amputation or laceration injuries!

!WARNING

NEVER place fingers or hands in the line of cut. If you slip, your hands or fingers may go into the blade and may be cut.



Crosscutting

Crosscutting is the process of cutting across the grain of wood. For plywood and other processed wood, crosscutting simply means cutting across the width of the material. Crosscuts can be 90° or angled using the miter gauge. Compound crosscuts are those where the miter is angled and the table tilted.

To make a crosscut:

1. Mark workpiece on edge where you want to begin cut.
2. Adjust the blade guide assembly to the correct height.
3. Adjust the miter gauge to the correct angle needed for cut.
4. Move fence out of the way. Place workpiece evenly against miter gauge, then line up mark with blade.
5. After all safety precautions have been met, turn bandsaw **ON** and wait for it to come to full speed. Slowly feed workpiece into the blade until blade is all the way through workpiece. The figure below shows an example of a crosscutting operation.

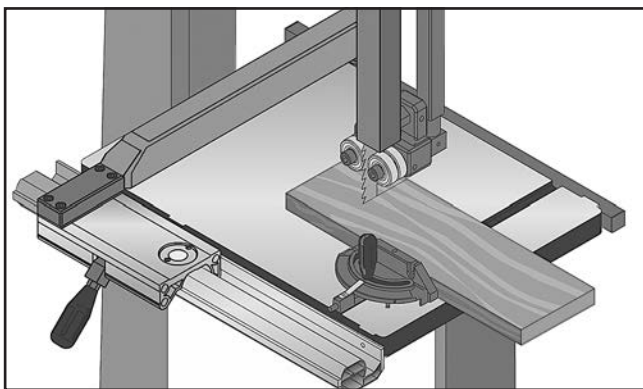

Figure 47. Example of a crosscutting operation with the miter gauge.

Resawing

"Resawing" means cutting the thickness of a board into two or more thinner boards (see the figure below for an example). The maximum height of a board that can be resawn is limited by the maximum cutting height of the bandsaw.

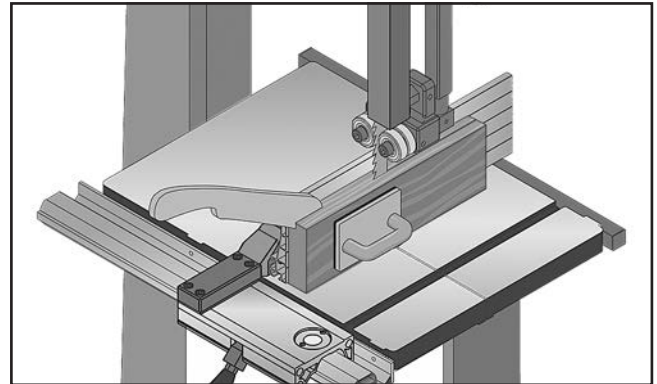

Figure 48. Example of a resawing operation.

One of the most important considerations for resawing is blade selection—a wide blade cuts straighter and is less prone to blade lead (see the **Blade Lead** subsection later in this manual for more information).

For most applications, use a blade with a hook or a skip tooth style. Choose blades with fewer teeth-per-inch (from 3 to 6 TPI), because they offer larger gullet capacities for clearing sawdust, which reduces heat buildup and strain on the motor.

!WARNING

When resawing thin pieces, a wandering blade (blade lead) can tear through the side of the workpiece, exposing your hands to the blade teeth. Always use push blocks when resawing and keep your hands clear of the blade.



Cutting Curves

When cutting curves, simultaneously feed and turn the stock carefully so that the blade follows the layout line without twisting. Use either a narrower blade or a blade with more TPI (teeth per inch), or make more relief cuts, to avoid having to back the workpiece away from the blade, especially if the curve is sharp.

Always make short cuts first, then proceed to the longer cuts. Relief cuts will also reduce the chance that the blade will be pinched or twisted. Relief cuts are cuts made through the waste portion of the workpiece and are stopped at the layout line. As you cut along the layout line, waste wood is released from the workpiece, alleviating any pressure on the back of the blade. Relief cuts also make backing the workpiece out easier once the saw blade has come to a stop, if needed.

NOTICE

The list below displays blade widths and the corresponding minimum radii for those blade widths.

Width	Min. Radius
1/8"	1/8"
3/16"	3/8"
1/4"	5/8"
3/8"	1 1/4"
1/2"	2 1/2"
5/8"	3 3/4"
3/4"	5 1/2"

Stacked Cuts

One of the benefits of a bandsaw is its ability to cut multiple copies of a particular shape by stacking a number of workpieces together. Before making stacked cuts, ensure that the table is perpendicular (90°) to the blade—otherwise, any error in this setting will be compounded in the upper workpieces.

To complete a stacked cut:

1. Align your pieces from top to bottom to ensure that each piece has adequate scrap to provide a clean, unhampered cut.
2. Secure all the pieces together in a manner that will not interfere with the cutting. Hot glue on the edges works well, as do brad nails through the waste portion. (Be careful not to cut into the brads or you may break the blade!)
3. On the face of the top piece, lay out the shape you intend to cut.
4. Make relief cuts perpendicular to the outline of your intended shape in areas where changes in blade direction could strain the woodgrain or cause the blade to bind.
5. Cut the stack of pieces as though you were cutting a single piece. Follow your layout line with the blade kerf on the waste side of your line (see the figure below for an example of stacked cut setup).

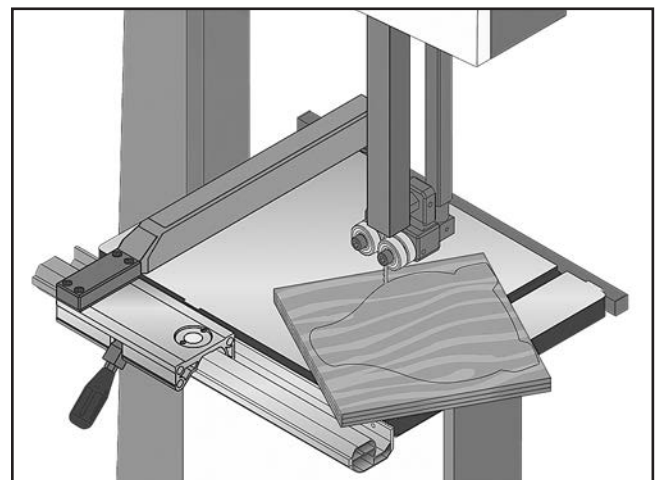

Figure 49. Example of a stacked cut setup.



SECTION 5: ACCESSORIES

!WARNING

Installing unapproved accessories may cause machine to malfunction, resulting in serious personal injury or machine damage. To reduce this risk, only install accessories recommended for this machine by Grizzly.

NOTICE

Refer to our website or latest catalog for additional recommended accessories.

Grizzly 93 1/2" Bandsaw Blades

Model	Width	TPI	Type	Gauge
G5152	1/8"	14	Raker	0.025
G5153	1/8"	18	Raker	0.025
G5154	3/16"	4	Skip	0.025
G5155	3/16"	10	Raker	0.025
G5156	3/16"	14	Raker	0.025
G5157	1/4"	4	Hook	0.025
G5158	1/4"	6	Hook	0.025
G5159	1/4"	10	Raker	0.025
G5160	1/4"	14	Raker	0.025
G5161	1/4"	18	Raker	0.025
G5162	3/8"	4	Hook	0.025
G5163	3/8"	6	Hook	0.025
G5164	3/8"	10	Raker	0.025
G5165	3/8"	14	Raker	0.025
G5166	1/2"	3	Hook	0.025
G5167	1/2"	4	Hook	0.025
G5168	1/2"	6	Hook	0.025
G5169	1/2"	10	Raker	0.025
G5170	1/2"	14	Raker	0.025
G5171	3/4"	3	Hook	0.032
G5172	3/4"	6	Hook	0.032
G5173	3/4"	10	Raker	0.032

H7584—Resaw Fence Retrofit Kit

This retrofit kit allows you to upgrade your existing aluminum fence for the G0555 bandsaw to a cast-iron fence with the 6" high resaw fence. Simply unbolt your existing aluminum fence (4 bolts) and bolt on the new cast-iron fence. Takes less than 3 minutes to switch over.



Figure 50. H7584 Resaw Fence Retrofit Kit for the G0555 bandsaw.

H3051—6" Extension Block Kit for G0555

Increase cutting capacity from 6" to 12" with this bolt-on 6" extension block kit. Includes extended blade guard and 105" x 3/8" x 6 TPI blade.

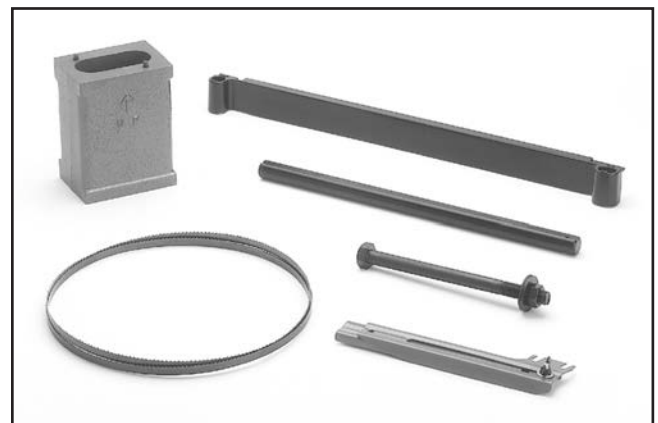
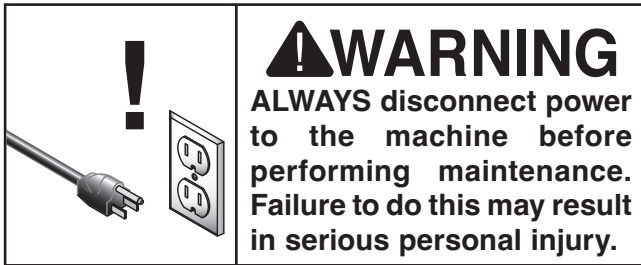

Figure 51. H3051 Extension Block Kit.

order online at www.grizzly.com or call 1-800-523-4777



SECTION 6: MAINTENANCE



Schedule

For optimum performance from this machine, this maintenance schedule must be strictly followed.

Ongoing

To minimize your risk of injury and maintain proper machine operation, shut down the machine immediately if you ever observe any of the items below, and fix the problem before continuing operations:

- Loose mounting bolts.
- Damaged saw blade.
- Worn or damaged wires.
- Any other unsafe condition.

Monthly Check

- V-belt tension, damage, or wear.
- Remove blade and clean sawdust on wheels and rubber tires.
- Clean/vacuum dust buildup off cabinet and motor.

Cleaning & Protecting

Cleaning the bandsaw is relatively easy. Vacuum away excess wood chips and sawdust, and wipe off the remaining dust with a dry cloth. If any resin has built up, use a resin dissolving cleaner to remove it.

Protect the unpainted cast iron surfaces on the table by wiping the table clean after every use—this ensures moisture from wood dust does not remain on bare metal surfaces.

Keep the table rust-free with regular applications of products like SLIPIT®.

Recommended Metal Protectants

G5562—SLIPIT® 1 Qt. Gel

G5563—SLIPIT® 11 Oz. Spray



Figure 52. Recommended products for protecting unpainted cast iron/steel parts on machinery.



Lubrication

The bearings on this bandsaw are pre-lubricated and sealed at the factory, and require no lubrication for the life of the bearings. All bearings are standard sizes, and replacements can be purchased from our parts department or a bearing supply store.

As for other items on this machine, such as adjustment controls, an occasional “shot” of light oil is just about all that is necessary. Before applying, however, wipe off any sawdust with a clean cloth, towel or dry paint brush, then spray on the lubricant.

Ensure that lubricant does not get on the pulleys or V-belt, which could cause V-belt deterioration or loss of power transfer due to slippage.

Redressing Rubber Tires

As the bandsaw ages, the rubber tires on the wheels may need to be redressed if they harden or glaze over. Redressing the rubber tires improves blade tracking and reduces vibration/blade lead.

If the rubber tires become too worn, then blade tracking will become extremely difficult. At that point, redressing will no longer be effective and the rubber tires must be replaced.

To redress the rubber tires:

1. DISCONNECT MACHINE FROM POWER!
2. Put on heavy leather gloves.
3. Remove the blade.
4. Clean any built-up sawdust from the rubber tires and wheels.
5. Hold 100-grit sandpaper against the rubber tire and rotate the wheel by hand. Only redress the rubber enough to expose a fresh rubber surface.
6. Re-install the blade, then make sure the blade tracking and tension are correct.



SECTION 7: SERVICE

Review the troubleshooting procedures in this section if a problem develops with your machine. If you need replacement parts or additional help with a procedure, call our Technical Support. **Note:** *Please gather the serial number and manufacture date of your machine before calling.*

Troubleshooting

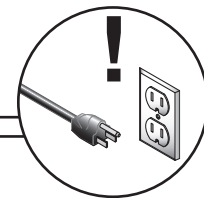

Motor & Electrical

Symptom	Possible Cause	Possible Solution
Machine does not start, or power supply breaker immediately trips after startup.	<ol style="list-style-type: none"> 1. Power supply is at fault/switched OFF. 2. Plug/receptacle is at fault or wired incorrectly. 3. Wiring is open/has high resistance. 4. Motor connection wired incorrectly. 5. Start capacitor is at fault (110V only). 6. Motor ON/OFF switch is at fault. 7. Centrifugal switch is at fault. 	<ol style="list-style-type: none"> 1. Ensure hot lines have correct voltage on all legs and main power supply is switched ON. 2. Test for good contacts; correct the wiring. 3. Check for broken wires or disconnected/corroded connections, and repair/replace as necessary. 4. Correct motor wiring connections (Page 54). 5. Test/replace. 6. Replace faulty ON/OFF switch. 7. Adjust/replace centrifugal switch.
Machine stalls or is underpowered.	<ol style="list-style-type: none"> 1. Incorrect workpiece material. 2. Feed rate too fast for task. 3. V-belt slipping. 4. Motor connection is wired incorrectly. 5. Plug/receptacle is at fault. 6. Motor bearings are at fault. 7. Motor has overheated. 8. Motor is at fault. 9. Centrifugal switch is at fault. 	<ol style="list-style-type: none"> 1. Use wood with correct moisture content (20% or less), without glues, and little pitch/resin. 2. Decrease feed rate. 3. Tighten/repair/replace (Pages 45 and 46). 4. Correct motor wiring connections (Page 54). 5. Test for good contacts; correct the wiring. 6. Test by rotating shaft; rotational grinding/loose shaft requires bearing replacement. 7. Clean off motor, let cool, and reduce workload. 8. Test/repair/replace. 9. Adjust/replace centrifugal switch.
Machine has vibration or noisy operation.	<ol style="list-style-type: none"> 1. Motor or component is loose. 2. V-belt worn or loose. 3. Motor fan is rubbing on fan cover. 4. Pulley is loose. 5. Machine is incorrectly mounted or sits unevenly on floor. 6. Blade is at fault. 7. Cast iron motor mount loose/broken. 8. Centrifugal switch is at fault. 9. Motor or spindle bearings are at fault. 	<ol style="list-style-type: none"> 1. Inspect/replace stripped or damaged bolts/nuts, use thread locking fluid, and retighten. 2. Tension V-belt (Page 45) or replace V-belt (Page 46). 3. Replace dented fan cover; replace damaged fan. 4. Tighten pulley set screw. 5. Adjust stand feet. 6. Replace blade. 7. Tighten/replace. 8. Adjust/replace centrifugal switch.. 9. Test by rotating shaft; rotational grinding/loose shaft requires bearing replacement.



Operations

Symptom	Possible Cause	Possible Solution
Machine slows when operating.	<ol style="list-style-type: none"> 1. Feeding workpiece too fast. 2. Blade is dull. 	<ol style="list-style-type: none"> 1. Reduce feed rate. 2. Replace blade (Page 36).
Ticking sound when the saw is running.	<ol style="list-style-type: none"> 1. Blade weld contacting guide/support bearings (a light tick is normal). 2. Blade weld may be failing. 	<ol style="list-style-type: none"> 1. Use file or stone to smooth and round the back of the blade; slightly loosen the blade guides. 2. Inspect and replace blade if necessary (Page 36).
Blade contacting table insert.	<ol style="list-style-type: none"> 1. Insert installed upside down or backwards. 2. Table improperly mounted or aligned. 	<ol style="list-style-type: none"> 1. Re-install insert a different way. 2. Align table (Page 28).
Vibration when cutting.	<ol style="list-style-type: none"> 1. Loose or damaged blade. 2. Sawdust buildup on wheels. 	<ol style="list-style-type: none"> 1. Tighten or replace blade (Page 36). 2. Clean all sawdust from rubber tires on wheels.
Burn marks on the edge of the cut.	<ol style="list-style-type: none"> 1. Too much side pressure when feeding workpiece; blade is binding. 2. Blade too wide for size of radius being cut. 	<ol style="list-style-type: none"> 1. Feed workpiece straight into the blade. 2. Install a smaller width blade/increase blade tension (Page 34).
Rough or poor quality cuts.	<ol style="list-style-type: none"> 1. Feeding workpiece too fast. 2. Blade guides adjusted incorrectly. 	<ol style="list-style-type: none"> 1. Reduce feed rate. 2. Re-adjust all blade support and guide bearings (Pages 24 and 26).
Sawdust buildup inside wheel covers.	<ol style="list-style-type: none"> 1. Clogged dust port. 2. Low CFM (airflow) from dust collection system. 	<ol style="list-style-type: none"> 1. Clean out dust port. 2. Three options: <ul style="list-style-type: none"> —Check dust lines for leaks or clogs. —Move dust collector closer to saw. —Install a more powerful dust collector.
Blade wanders or doesn't cut straight.	<ol style="list-style-type: none"> 1. Blade lead. 2. Sawdust buildup on wheels. 	<ol style="list-style-type: none"> 1. Refer to Blade Lead on Page 50. 2. Clean all sawdust from rubber tires on wheels.
Cuts are not square (vertically).	<ol style="list-style-type: none"> 1. Table tilt is not adjusted to 0° or positive stop has moved out of adjustment. 2. Table tilt scale pointer is not calibrated. 3. Table is not square to the blade. 	<ol style="list-style-type: none"> 1. Adjust table tilt to 0°; readjust positive stop if necessary (Page 27). 2. Calibrate table tilt scale pointer to 0° (Page 27). 3. Shim table (Page 46).

Miscellaneous

Symptom	Possible Cause	Possible Solution
Tensioner mechanism has poor range of motion.	<ol style="list-style-type: none"> 1. Spacer blocks on quick-release tension mechanism have moved out of adjustment. 	<ol style="list-style-type: none"> 1. Reset the blade tensioner (Page 51).
Blade tension scale is grossly inaccurate.	<ol style="list-style-type: none"> 1. The spring in the blade tension mechanism has lost its "spring." This is caused by not releasing the blade tension when not in use or frequently over-tensioning the bandsaw. 	<ol style="list-style-type: none"> 1. Replace spring in the blade tension mechanism, then take better care of the bandsaw by releasing tension when not in use and not over-tensioning the blade.
Wheel is noisy.	<ol style="list-style-type: none"> 1. Wheel bearing is worn out. 2. V-belt is too tight (lower wheel). 	<ol style="list-style-type: none"> 1. Replace the wheel bearing. 2. Check/loosen the belt tension (Page 45).
Blade does not track consistently, correctly, or at all.	<ol style="list-style-type: none"> 1. Wheels are not coplanar or aligned with each other. 2. Rubber tires on wheels are worn out. 	<ol style="list-style-type: none"> 1. Adjust wheels to be coplanar/aligned with each other (Page 47). 2. Redress the rubber tires on the wheels (Page 42); replace the rubber tires on the wheels.



V-Belt Tension

To ensure optimum power transmission from the motor to the blade, the V-belt must be in good condition and operate under proper tension.

V-belt tension should be checked at least every month—more often if the bandsaw is used daily. If the belt shows signs of cracks, fraying, and excessive wear, replace it as instructed in the **Service** section later in this manual.

Checking V-Belt Tension

1. DISCONNECT MACHINE FROM POWER!
2. Open the lower wheel cover.
3. The V-belt is properly tensioned if there is approximately $\frac{1}{4}$ " deflection of the V-belt when you apply moderate pressure to it between the pulleys (see the illustration in the following figure).
 - If the V-belt is not properly tensioned, perform the following **Tensioning V-Belt** procedure.

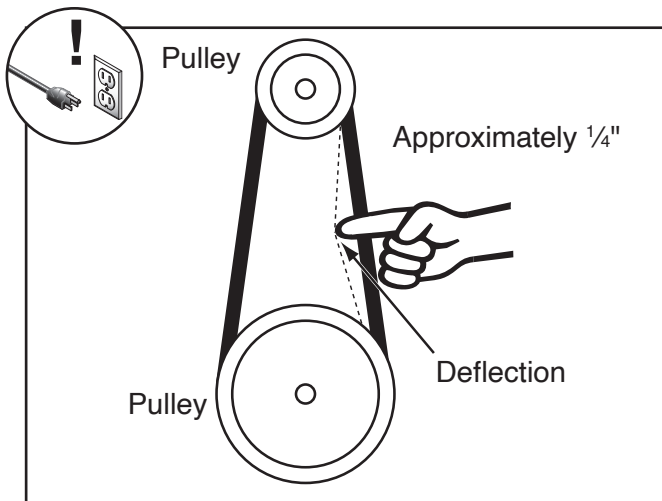

Figure 53. Checking the V-belt tension.

Tensioning V-Belt

Tool Needed	Qty
Hex Wrench 6mm.....	1

To properly tension the V-belt:

1. DISCONNECT MACHINE FROM POWER!
2. Open the lower wheel cover and loosen the motor adjustment and hinge cap screws shown in **Figure 54**.

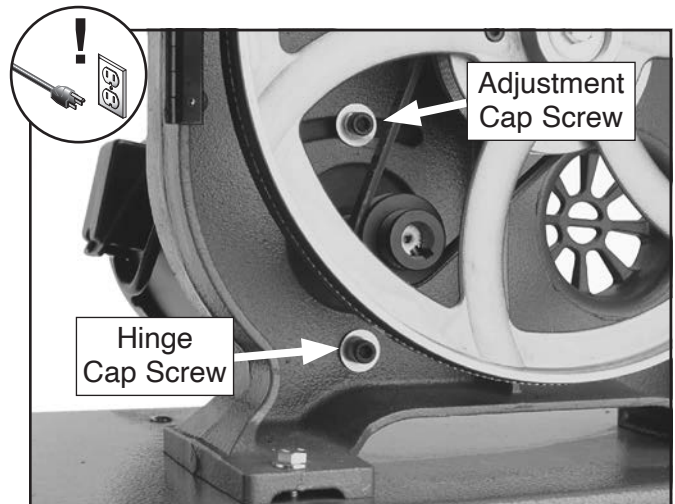

Figure 54. Locations of the motor adjustment and hinge cap screws.

3. Push the motor to the left (as viewed from the front of the machine) until there is approximately $\frac{1}{4}$ " deflection in the V-belt between the pulley when moderate pressure is applied.
4. Re-tighten both cap screws and close the wheel cover.



Replacing V-Belt

To ensure optimum power transmission from the motor to the blade, the V-belt must be in good condition and operate under proper tension.

If the belt shows signs of cracks, fraying, and excessive wear, replace it.

Tools Needed	Qty
Hex Wrench 6mm.....	1
Wrench or Socket 13mm.....	1
Replacement V-Belt (Part No. P0555068)	1

To replace the V-belt:

1. DISCONNECT MACHINE FROM POWER!
2. Put on heavy leather gloves and remove the blade from the machine.
3. Loosen the motor adjustment and hinge cap screws shown in **Figure 55**.

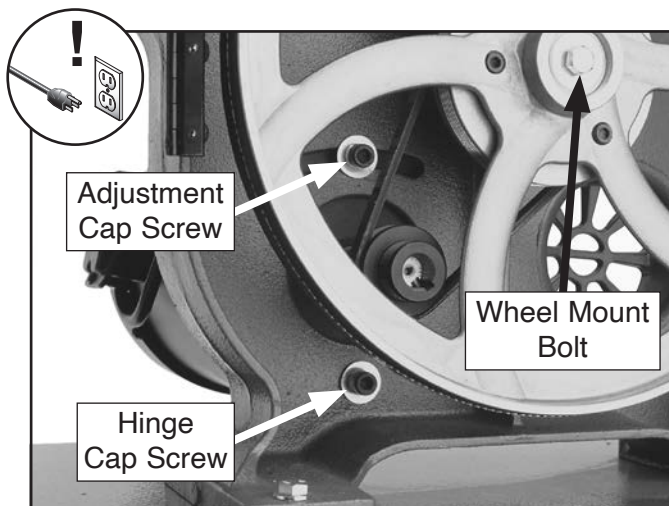

Figure 55. Locations of the wheel mount bolt, and motor adjustment and hinge cap screws.

4. Move the motor to the right (as viewed from the front of the bandsaw) so that the adjustment cap screw slides to the right in the slot—this will release the V-belt tension.
5. Roll the V-belt off the pulleys.

6. Unthread the wheel mount bolt clockwise (left-hand thread), and remove it and the flat washer from the wheel hub.
7. Taking care not to misplace the shaft key, slide the wheel from the shaft.
8. Align the wheel keyway with the shaft key and slide the wheel back onto the shaft.
9. Secure the wheel with the wheel mount bolt and flat washer.
10. Position the V-belt on the desired pulleys, then properly tension it, as instructed in the **V-Belt Tension** subsection on **Page 45**.
11. Replace the blade, then properly track and tension it (see **Pages 21** and **24**).

Shimming Table

To ensure accuracy when cutting stacked cuts or circles, the table must be 90° to the back of the blade, as shown in the figure below.

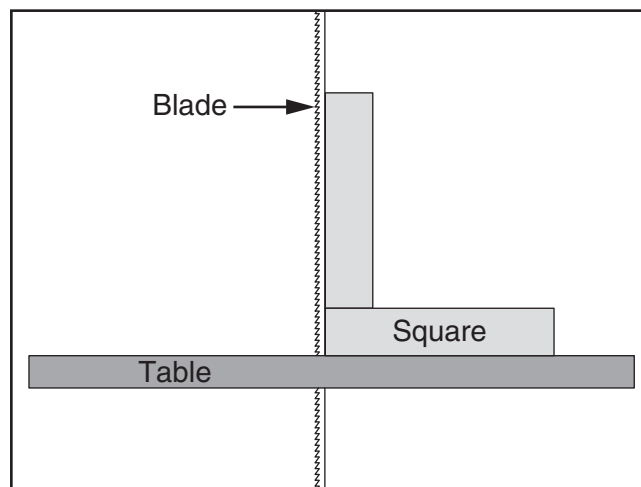

Figure 56. Checking the table to be perpendicular to the back of the blade.

If the table is not perpendicular to the back of the blade, correct this condition by placing shim stock between the table and trunnions underneath it.

Tip: For fine adjustments, use electrical washers on the bolts that secure the table.



Wheel Alignment

Wheel alignment is one of the most critical factors for optimal performance from your bandsaw. Wheels are properly aligned when they are parallel with each other and in the same plane or “coplanar” (see the illustration in the figure to the right).

Heat, vibration, wandering, blade wear, tire wear and overall bandsaw wear are considerably decreased when the wheels are parallel and coplanar. Additionally, wheels that are parallel and coplanar automatically track the blade by balancing it on the crown of the wheel—this is known as “coplanar tracking.”

Bringing the wheel into alignment may require a combination of shimming a wheel and center/lateral tracking the upper blade.

Tools Needed	Qty
Straightedge 4 ft.....	1
Fine Ruler.....	1
Wrench or Socket 13mm.....	1
Wrench or Socket 19mm.....	1

Checking Wheel Alignment

1. DISCONNECT MACHINE FROM POWER!
2. Remove the table.
3. With the blade on and properly tensioned, hold a straightedge close to the center of both wheels. Make sure the straightedge fully extends across the rims of both wheels, as shown in the figure below.

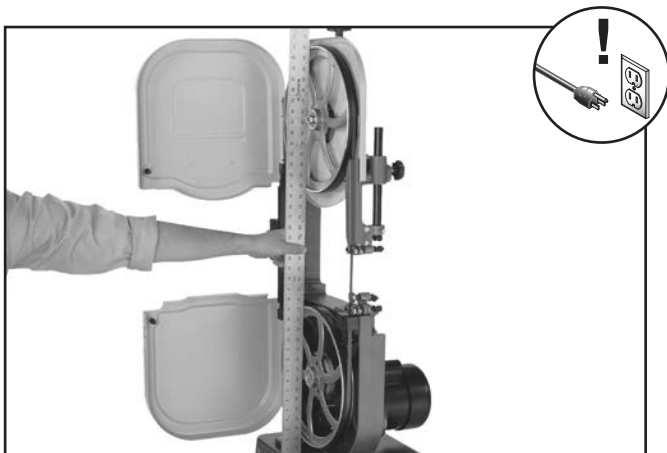

Figure 57. Checking if the wheels are coplanar.

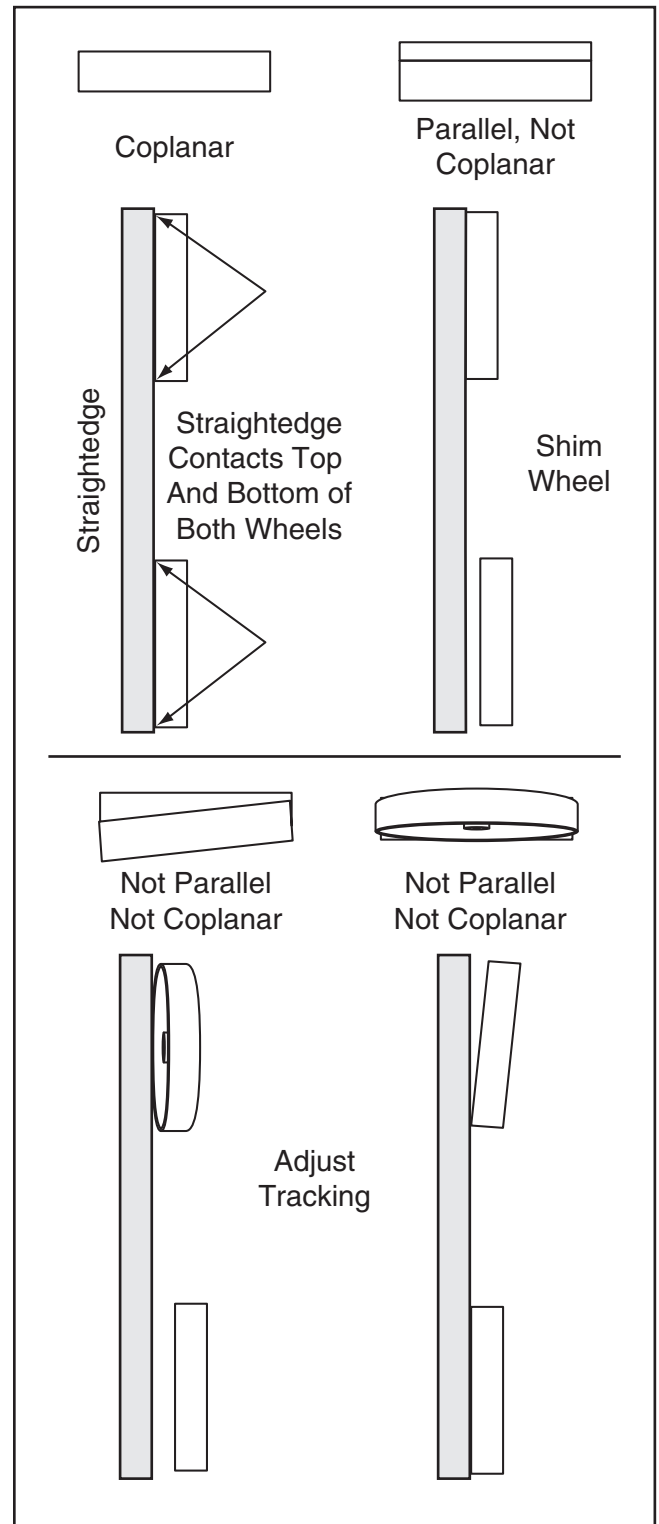

Figure 58. Wheel alignment illustration.



- If the wheels are parallel and coplanar, the straightedge will touch the top and bottom rims on both wheels. No further adjustment is required.
- If the wheels are parallel but not coplanar, the straightedge will touch the top and bottom rims on one wheel, but will not touch either rim on the other wheel. In this case, shim the wheel that does not touch the straightedge, as instructed in the following **Shimming a Wheel** procedure.
- If the wheels are not coplanar, the straightedge will touch both rims of one wheel, but at an angle to the other wheel. In this case, you will need to adjust the tracking of the upper wheel.

If the upper wheel is tilted from top to bottom only, perform the **Center Blade Tracking** procedure as instructed earlier in this manual.

If the upper wheel is tilted from side to side, perform **Upper Wheel Lateral Adjustment** procedure that follows.

Shimming a Wheel

A wheel that is parallel with the other wheel, but is not coplanar, must be shimmed by the distance that it is not in the same plane with the other wheel.

To shim a wheel:

1. DISCONNECT MACHINE FROM POWER!
2. Adjust the upper wheel tracking so that it is parallel with the bottom wheel.

3. With the straightedge touching both rims of the wheel that does not need to be adjusted, measure the distance away from the other wheel with a fine ruler, as shown in the figure below. The distance measured with the ruler is the distance this wheel must be shimmed.

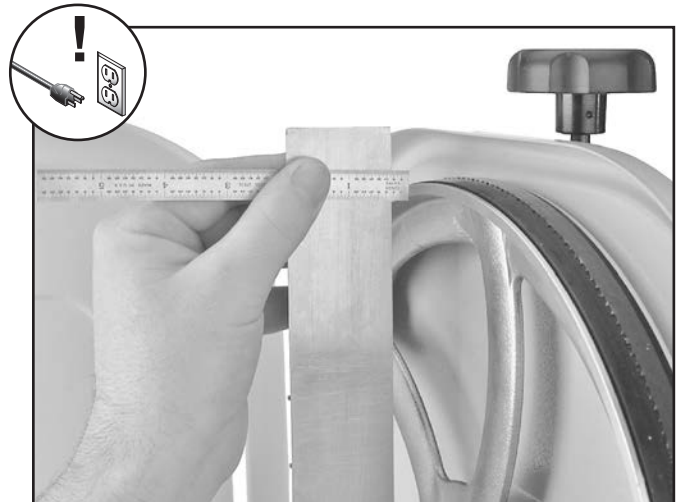

Figure 59. Measuring the distance to shim the wheel to be coplanar.

4. Remove the wheel to be shimmed, then place shimming washers in the amount measured in **Step 3** onto the wheel shaft.
5. Re-install the wheel and secure it in place.
6. Re-install the blade, then properly tension it for operation.

Note: *Often the wheels may be coplanar with the blade loose, then be pulled out of alignment when it is tightened.*

7. Perform the previous **Checking Wheel Alignment** procedure. If necessary to make the wheels parallel, repeat this procedure.
8. When you are satisfied with the adjustment, re-install the blade and close the wheel covers.



Upper Wheel Lateral Adjustment

If the upper wheel is tilted laterally (side to side), perform the following procedure to make it coplanar with the lower wheel.

There are two set screws in the upper wheel bracket, shown in **Figures 60–61**, that adjust the wheel tilt from side to side.

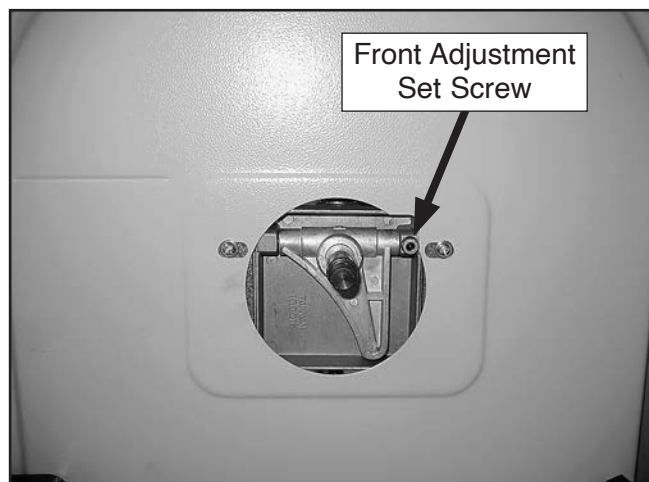

Figure 60. Front lateral adjustment set screw (viewed with the upper wheel removed).

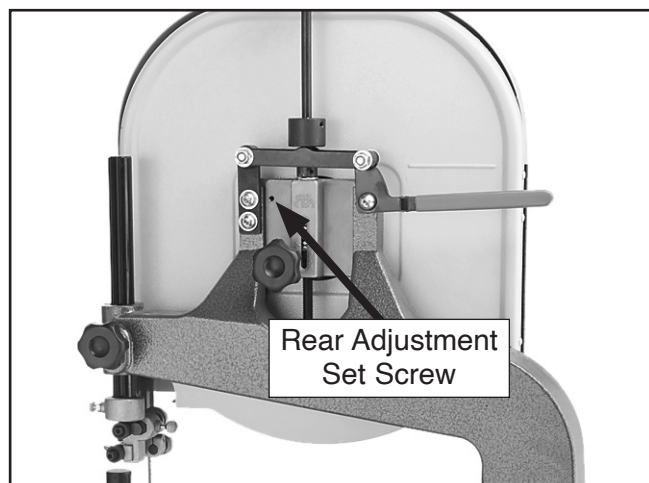

Figure 61. Rear lateral adjustment set screw.

Tools Needed

Qty

Hex Wrench 2.5mm.....	1
Wrench or Socket 19mm.....	1

To adjust the upper wheel laterally:

1. DISCONNECT MACHINE FROM POWER!
2. Remove the blade from the machine.
3. Remove the hex nut that secures the upper wheel, then slide the wheel from the shaft.
4. Thread one set screw out and thread the other set screw in the same amount to tilt the wheel laterally.

For instance, to tilt the right side of the upper wheel back, thread the rear set screw out and thread the front set screw in the same amount.

5. Slide the upper wheel back on the shaft, then repeat the **Checking Wheel Alignment** procedure and, if necessary, repeat this procedure until the upper wheel is coplanar with the lower wheel.



Blade Lead

Bandsaw blades may wander off the cut line when sawing, as shown in the figure below. This is called blade lead.

Blade lead is usually caused by too fast of a feed rate, a dull or abused blade, or improper blade tension. If your blade is sharp/undamaged, properly tensioned, and you still have blade lead, perform the following procedures.

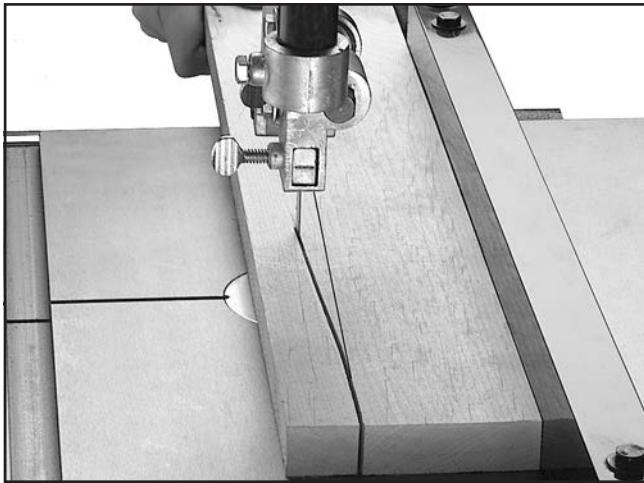

Figure 62. Example of blade lead.

Correcting Blade Lead

1. Make sure the blade is properly tensioned and the blade guides are adjusted correctly.
2. Use less pressure when feeding the workpiece through the cut—this will reduce the feed rate.
3. Make sure the miter slot and fence are parallel to the blade line (see the **Aligning Table** and **Aligning Fence** procedures in this manual for detailed information).
4. If after **Steps 1–3** there is still blade lead present, compensate for this condition by skewing the fence or shifting the table, as instructed in the following procedures.

Skewing the Fence

1. Cut a piece of scrap wood approximately $\frac{3}{4}$ " thick x 3" wide x 17" long. On the wide face of the board, draw a straight line parallel to the long edge.
2. Slide the bandsaw fence out of the way and cut halfway through the board on the line by pushing it into the blade. Turn the bandsaw **OFF** and wait for the blade to stop. Do not move the board.
3. Clamp the board to the bandsaw table, then slide the fence over to the board so it barely touches one end of the board.
4. Use a 4mm hex wrench to loosen the four fence adjustment cap screws on top of the fence, skew the fence so that it is parallel with the scrap piece, then re-tighten the cap screws.
5. Make a few cuts using the fence.
 - If blade lead is still present, repeat **Steps 1–4** until the blade and fence are parallel with each other.
 - Or, shift the table, as instructed in the following procedure.

Shifting the Table

1. On a scrap piece of wood, mark a line that is perpendicular to the front edge.
2. Cut halfway through the board on the line by pushing it into the blade.
3. Turn the bandsaw **OFF** and wait for the blade to stop.
4. Disconnect the bandsaw from power, then use a 10mm wrench to loosen the six hex bolts underneath the table that secure it to the trunnion brackets.
5. Shift the table to compensate for the blade lead, re-tighten the hex bolts, then re-connect the bandsaw to power.
6. Repeat **Steps 1–5** until there is no longer any blade lead.



Blade Tensioner

The blade tensioner may need to be reset for one of the following reasons:

- The blade tension quick release lever will not move down into the horizontal position when the tension scale is correctly adjusted for the installed blade.
- You have installed a blade of a different length.

Tool Needed	Qty
Hex Wrench 2.5mm.....	1

To reset the blade tensioner:

1. DISCONNECT MACHINE FROM POWER!
2. Move the blade tension lever up to the vertical position to release blade tension, then loosen the set screws on both spacers shown in **Figure 63**.

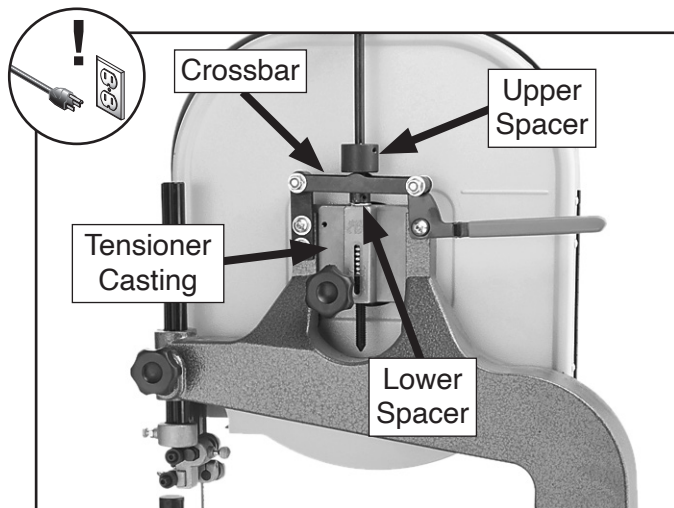

Figure 63. Locations of spacers and tensioner crossbar.

3. Rotate the spacers fully away from the crossbar, then rotate the blade tension knob so that the red marker is at the blade width mark for the installed blade.
4. Pull the quick release lever down to the horizontal position.
5. Pull up on the tension knob to apply as much tension on the blade as possible.
6. While maintaining the upward pressure on the tension knob, thread the upper spacer down until it touches the crossbar, then re-tighten the set screw to secure it in place.
7. Thread the lower spacer down until it touches the top of the tensioner casting, then thread it back up 1–2 turns to leave a small space above the casting and re-tighten the set screw to secure the setting.
8. Move the quick release lever up to the vertical position and make sure there is no tension on the blade. If all the tension is not released, the lower spacer needs to be threaded farther down the shaft toward the tensioner casting.



Fence Scale Calibration

You may need to recalibrate the fence scale after changing or adjusting the blade, or if the scale is not producing accurate cuts. Recalibrate the fence scale by adjusting the hairline indicator on the fence and testing your adjustment by cutting a piece of scrap wood.

Tools Needed	Qty
Phillips Screwdriver #1	1

To calibrate the scale:

1. Set the fence anywhere along the scale and locate a piece of scrap wood with at least one straight edge.

Note: Joint the edge with a jointer if needed to make the edge straight.

2. Hold the straight edge of the workpiece firmly against the fence, and feed the workpiece through the saw blade with a push stick.
3. Measure the width of the cut workpiece. The width of the workpiece should match the reading on the fence scale.

4. If the reading on the scale is not the same as the width of the cut workpiece, loosen the two screws on the magnifying window (see **Figure 64**) and adjust it to match the width of the cut workpiece.



Figure 64. Fence scale window and screws.

5. Re-tighten the screws—the scale is now correctly calibrated.



SECTION 8: WIRING

These pages are current at the time of printing. However, in the spirit of improvement, we may make changes to the electrical systems of future machines. Compare the manufacture date of your machine to the one stated in this manual, and study this section carefully.

If there are differences between your machine and what is shown in this section, call Technical Support at (570) 546-9663 for assistance BEFORE making any changes to the wiring on your machine. An updated wiring diagram may be available. **Note:** *Please gather the serial number and manufacture date of your machine before calling. This information can be found on the main machine label.*

⚠ WARNING

Wiring Safety Instructions

SHOCK HAZARD. Working on wiring that is connected to a power source is extremely dangerous. Touching electrified parts will result in personal injury including but not limited to severe burns, electrocution, or death. Disconnect the power from the machine before servicing electrical components!

MODIFICATIONS. Modifying the wiring beyond what is shown in the diagram may lead to unpredictable results, including serious injury or fire. This includes the installation of unapproved after-market parts.

WIRE CONNECTIONS. All connections must be tight to prevent wires from loosening during machine operation. Double-check all wires disconnected or connected during any wiring task to ensure tight connections.

CIRCUIT REQUIREMENTS. You MUST follow the requirements at the beginning of this manual when connecting your machine to a power source.

WIRE/COMPONENT DAMAGE. Damaged wires or components increase the risk of serious personal injury, fire, or machine damage. If you notice that any wires or components are damaged while performing a wiring task, replace those wires or components.

MOTOR WIRING. The motor wiring shown in these diagrams is current at the time of printing but may not match your machine. If you find this to be the case, use the wiring diagram inside the motor junction box.















CAPACITORS/INVERTERS. Some capacitors and power inverters store an electrical charge for up to 10 minutes after being disconnected from the power source. To reduce the risk of being shocked, wait at least this long before working on capacitors.

EXPERIENCING DIFFICULTIES. If you are experiencing difficulties understanding the information included in this section, contact our Technical Support at (570) 546-9663.

NOTICE

The photos and diagrams included in this section are best viewed in color. You can view these pages in color at www.grizzly.com.

COLOR KEY

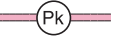
BLACK		BLUE		YELLOW		LIGHT BLUE	
WHITE		BROWN		YELLOW GREEN		BLUE WHITE	
GREEN		GRAY		PURPLE		TURQUOISE	
RED		ORANGE		PINK			



Wiring Diagram



Figure 65. Motor and ON/OFF switch locations.

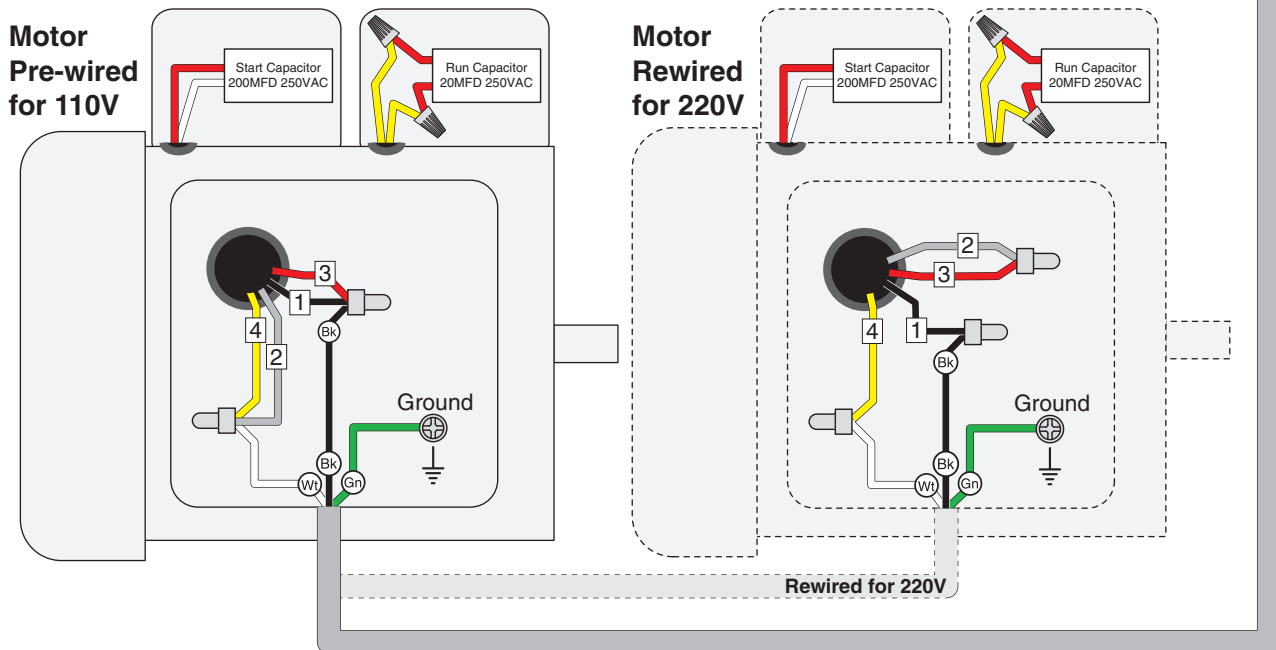
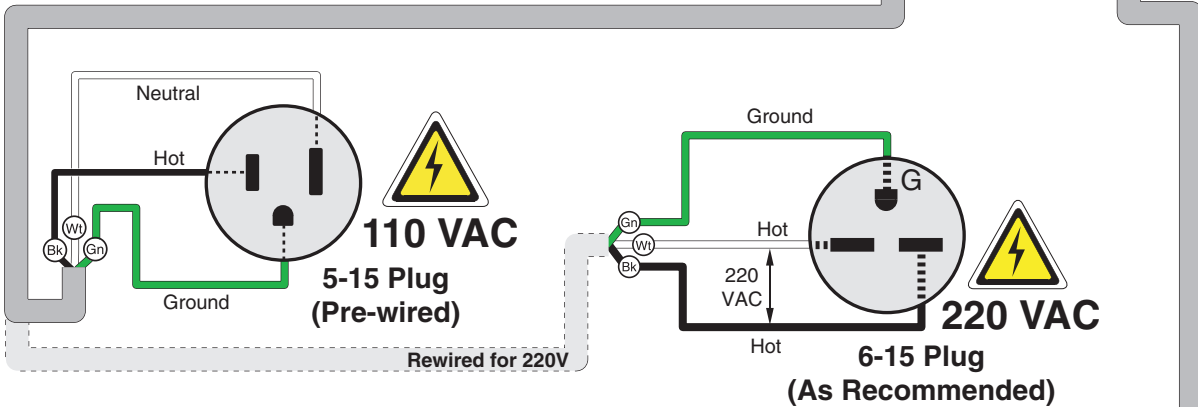
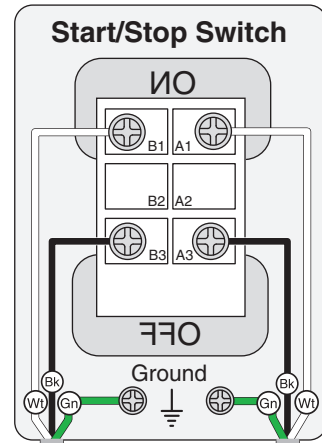

SECTION 9: PARTS

We do our best to stock replacement parts when possible, but we cannot guarantee that all parts shown are available for purchase. Call (800) 523-4777 or visit www.grizzly.com/parts to check for availability.

Main

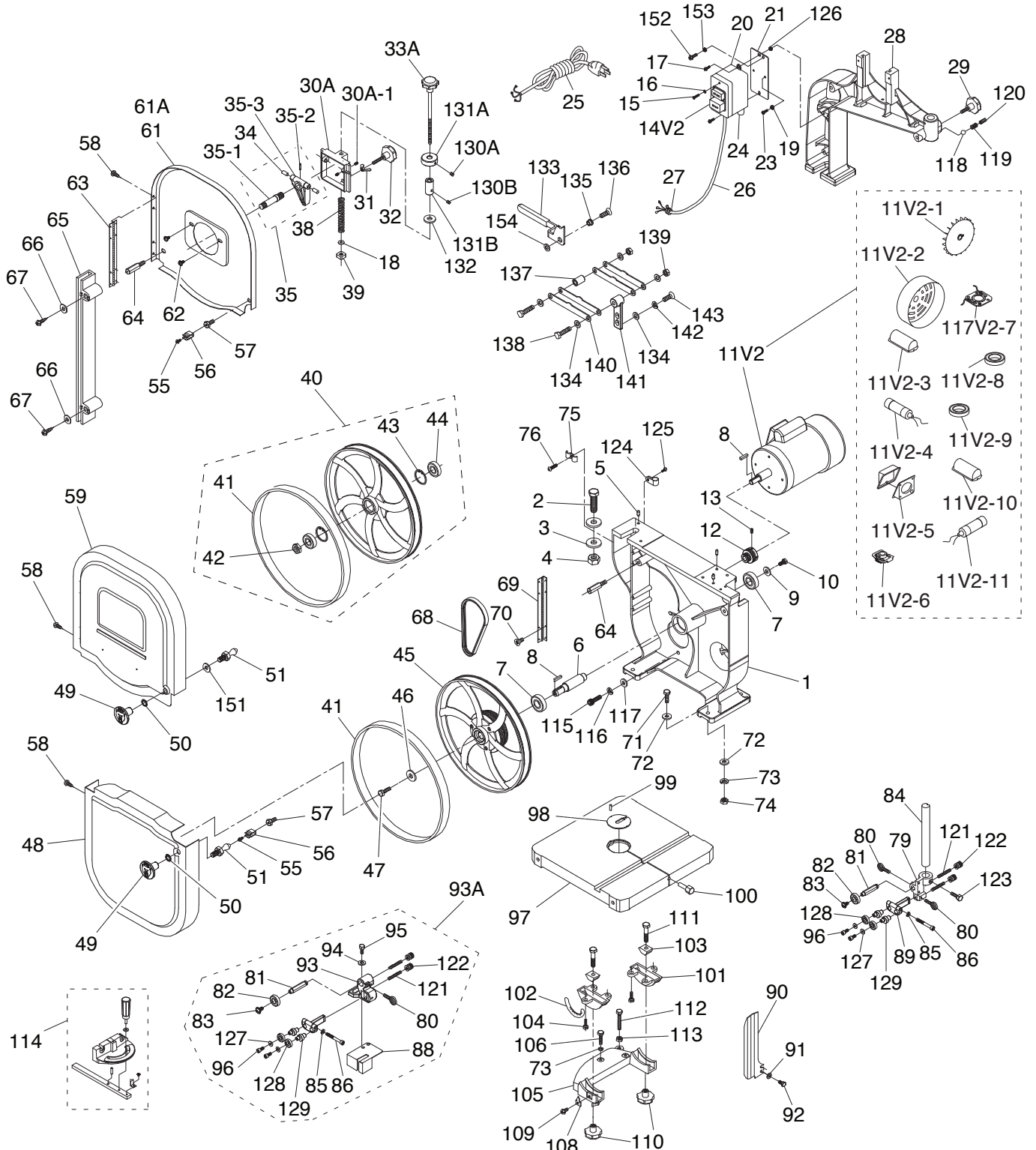

Main Parts List

REF	PART #	DESCRIPTION
1	P0555001	BASE
2	P0555002	HEX BOLT M16-2 X 55
3	P0555003	FLAT WASHER 16MM
4	P0555004	HEX NUT M16-2
5	P0555005	ALIGNMENT PIN
6	P0555006	LOWER WHEEL SHAFT
7	P0555007	BALL BEARING 6204 LLU
8	P0555008	KEY 5 X 5 X 25
9	P0555009	SHAFT WASHER 30 X 8 X 3MM
10	P0555010	PHLP HD SCR M8-1.25 X 16
11V2	P0555011V2	MOTOR 1HP 110/220V 60HZ V2.05.11
11V2-1	P0555011V2-1	MOTOR FAN
11V2-2	P0555011V2-2	MOTOR FAN COVER
11V2-3	P0555011V2-3	S CAPACITOR COVER
11V2-4	P0555011V2-4	S CAPACITOR 200M 250V
11V2-5	P0555011V2-5	JUNCTION BOX
11V2-6	P0555011V2-6	CENTRIFUGAL SWITCH
11V2-7	P0555011V2-7	CONTACT PLATE
11V2-8	P0555011V2-8	BALL BEARING 6202ZZ
11V2-9	P0555011V2-9	BALL BEARING 6205ZZ
11V2-10	P0555011V2-10	R CAPACITOR COVER
11V2-11	P0555011V2-11	R CAPACITOR 20M 250V
12	P0555012	MOTOR PULLEY
13	P0555013	SET SCREW M6-1 X 12
14V2	P0555014V2	ON/OFF SWITCH 110/220V V2.05.11
15	P0555015	TAP SCREW M3.5 X 12
16	P0555016	FLAT WASHER 4MM
17	P0555017	PHLP HD SCR M5-.8 X 16
18	P0555018	TENSION INDICATOR
19	P0555019	EXT TOOTH WASHER 5MM
20	P0555020	SWITCH BOX
21	P0555021	SWITCH BOX MOUNT
23	P0555023	PHLP HD SCR M5-.8 X 6
24	P0555024	STRAIN RELIEF
25	P0555025	POWER CORD 16G 3C 6FT 5-15
26	P0555026	MOTOR CORD
27	P0555027	STRAIN RELIEF
28	P0555028	UPPER FRAME ARM
29	P0555029	KNOB BOLT M10-1.5 X 30
30A	P0555030A	UPPER WHEEL SLIDING BRACKET V2.07.07
30A-1	P0555030A-1	SET SCREW M5-.8 X 8
31	P0555031	WING NUT M8-1.25
32	P0555032	KNOB BOLT M8-1.25 X 45
33A	P0555033A	BLADE ADJ SCR ASSY 7" THREAD
34	P0555034	DOWEL PIN
35	P0555035	UPPER WHEEL SHAFT HINGE ASSY
35-1	P0555035-1	UPPER WHEEL SHAFT
35-2	P0555035-2	ROLL PIN 3 X 6
35-3	P0555035-3	UPPER WHEEL SHAFT HINGE
38	P0555038	COMPRESSION SPRING 3.8 X 13.5 X 81
39	P0555039	SQUARE NUT M10-1.5
40	P0555040	UPPER WHEEL ASSY.
41	P0555041	WHEEL TIRE 14"
42	P0555042	HEX NUT M12-1.25
43	P0555043	INT RETAINING RING 35MM

REF	PART #	DESCRIPTION
44	P0555044	BALL BEARING 6202 LLU
45	P0555045	LOWER WHEEL ASSY W/TIRE
46	P0555046	SHAFT WASHER 30 X 8 X 3MM
47	P0555047	HEX BOLT M8-1.25 X 20 LH
48	P0555048	LOWER WHEEL COVER
49	P0555049	KNOB M8-1.25
50	P0555050	INT TOOTH WASHER 8MM
51	P0555051	DOOR LATCH STUD M8-1.25 X 14
55	P0555055	PHLP HD SCR M5-.8 X 12
56	P0555056	CATCH
57	P0555057	ALIGNMENT BOLT M5-.8 X 27
58	P0555058	TAP SCREW M4 X 8
59	P0555059	FRONT UPPER WHEEL COVER
61A	P0555061A	REAR UPPER WHEEL COVER V2.07.07
62	P0555062	FLANGE SCREW M5-.8 X 8
63	P0555063	UPPER WHEEL COVER HINGE
64	P0555064	WHEEL COVER STANDOFF
65	P0555065	LEFT BLADE GUARD
66	P0555066	SPECIAL FLANGE WASHER 4MM
67	P0555067	TAP SCREW M3.5 X 16
68	P0555068	RIBBED V-BELT 200J5
69	P0555069	LOWER WHEEL COVER HINGE
70	P0555070	FLAT HD SCR M5-.8 X 10
71	P0555071	HEX BOLT M8-1.25 X 35
72	P0555072	FLAT WASHER 8MM
73	P0555073	LOCK WASHER 8MM
74	P0555074	HEX NUT M8-1.25
75	P0555075	CORD CLAMP
76	P0555076	PHLP HD SCR M5-.8 X 12
79	P0555079	GUIDE POST BRACKET
80	P0555080	THUMB SCREW M6-1 X 16
81	P0555081	GUIDE SPACING SLEEVE
82	P0555082	BALL BEARING 6000ZZ
83	P0555083	FLANGE SCREW M6-1 X 8
84	P0555084	GUIDE POST
85	P0555085	LOCK WASHER 5MM
86	P0555086	CAP SCREW M5-.8 X 40
88	P0555088	LOWER RIGHT BLADE GUARD
89	P0555089	UPPER GUIDE BRACKET
90	P0555090	UPPER RIGHT BLADE GUARD
91	P0555091	FLAT WASHER 6MM
92	P0555092	HEX BOLT M6-1 X 8
93	P0555093	LOWER GUIDE BRACKET
94	P0555094	FLAT WASHER 6MM
95	P0555095	HEX BOLT M6-1 X 20
96	P0555096	CAP SCREW M5-.8 X 12
97	P0555097	TABLE
98	P0555098	TABLE INSERT
99	P0555099	ROLL PIN 3 X 8
100	P0555100	TABLE PIN
101	P0555101	TRUNNION
102	P0555102	SCALE
103	P0555103	TRUNNION CLAMP SHOE
104	P0555104	HEX BOLT M6-1 X 12
105	P0555105	TRUNNION SUPPORT BRACKET



Main Parts List (Cont.)

REF	PART #	DESCRIPTION
106	P0555106	HEX BOLT M8-1.25 X 30
108	P0555108	POINTER
109	P0555109	FLANGE SCREW M5-.8 X 6
110	P0555110	KNOB M10-1.5
111	P0555111	HEX BOLT M10-1.5 X 50
112	P0555112	TRUNNION HEX BOLT M8-1.25 X 80
113	P0555113	HEX NUT M8-1.25
114	P0555114	MITER GAUGE ASSEMBLY
115	P0555115	CAP SCREW M8-1.25 X 25
116	P0555116	LOCK WASHER 8MM
117	P0555117	FLAT WASHER 8MM
118	P0555118	STEEL BALL
119	P0555119	COMPRESSION SPRING 1.5 X 5 X 9
120	P0555120	SET SCREW M10-1.5 X 10
121	P0555121	SET SCREW M8-1 X 35
122	P0555122	MICRO ADJUSTING NUT 1.65
123	P0555123	HEX BOLT M6-1 X 20
124	P0555124	CORD CLAMP
125	P0555125	PHLP HD SCR M5-.8 X 12
126	P0555126	LOCK NUT M4-.7
127	P0555127	FLAT WASHER 5MM
128	P0555128	BALL BEARING 608ZZ

REF	PART #	DESCRIPTION
129	P0555129	ECCENTRIC SHAFT
130A	P0555130A	SET SCREW M5-.8 X 8
130B	P0555130B	SET SCREW M5-.8 X 5
131A	P0555131A	UPPER LOCK COLLAR
131B	P0555131B	LOWER LOCK COLLAR
132	P0555132	FLAT WASHER 10MM
133	P0555133	QUICK RELEASE LEVER
134	P0555134	FLAT WASHER 8MM
135	P0555135	BUSHING
136	P0555136	CAP SCREW M6-1 X 16
137	P0555137	SPACER
138	P0555138	HEX BOLT M8-1.25 X 40
139	P0555139	LOCK NUT M8-1.25
140	P0555140	SUPPORT PLATE
141	P0555141	PIVOT ARM
142	P0555142	LOCK WASHER 8MM
143	P0555143	HEX BOLT M8-1.25 X 20
151	P0555151	FLAT WASHER 8MM
152	P0555152	PHLP HD SCR M5-.8 X 12
153	P0555153	EXT TOOTH WASHER 5MM
154	P0555154	SPACER 8MM



Stand

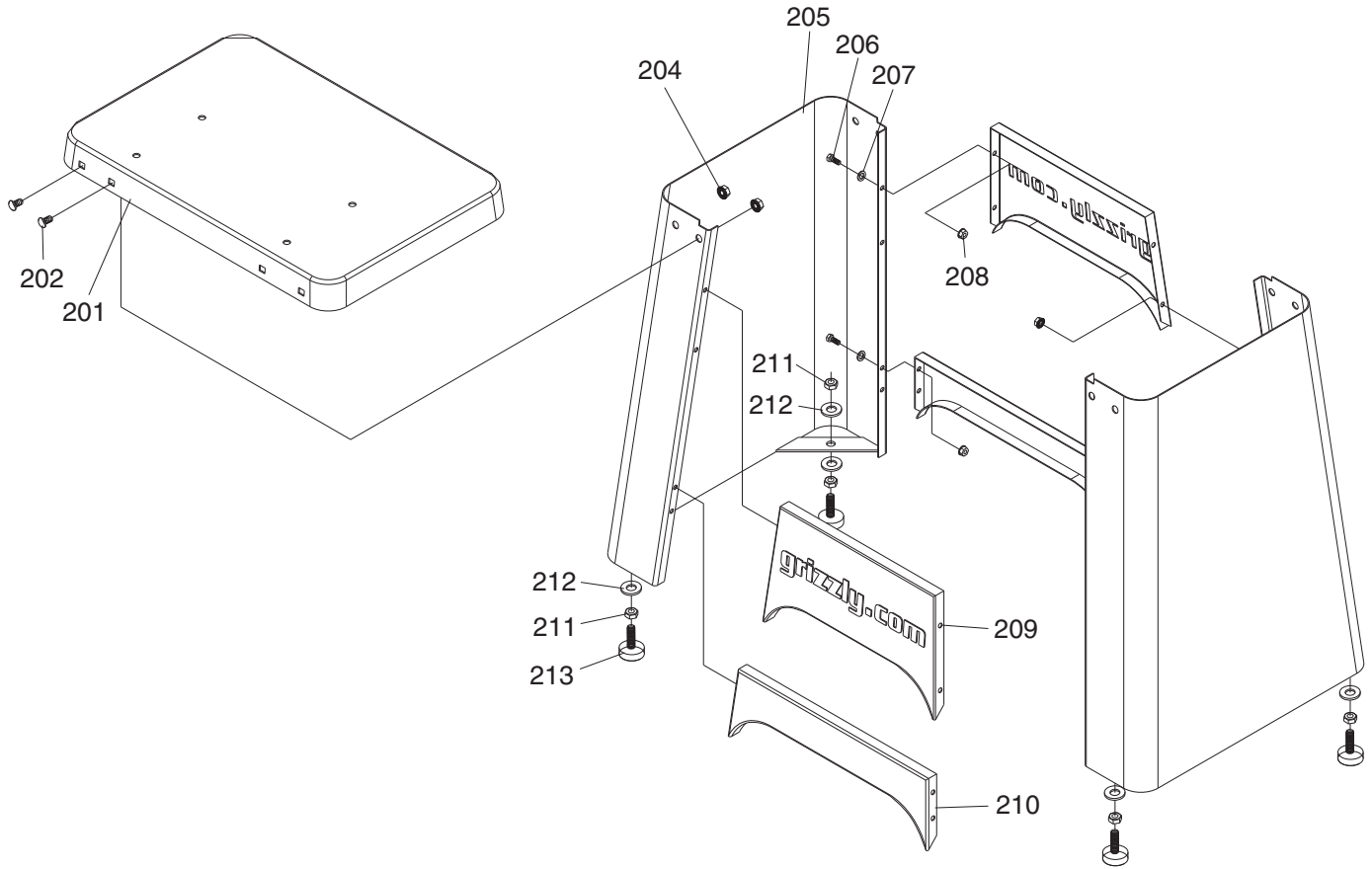

REF	PART #	DESCRIPTION
201	P0555201	STAND TOP
202	P0555202	CARRIAGE BOLT M8-1.25 X 16
204	P0555204	FLANGE NUT M8-1.25
205	P0555205	STAND SIDE
206	P0555206	HEX BOLT M6-1 X 16
207	P0555207	FLAT WASHER 6MM

REF	PART #	DESCRIPTION
208	P0555208	FLANGE NUT M6-1
209	P0555209	UPPER STAND BRACE
210	P0555210	LOWER STAND BRACE
211	P0555211	HEX NUT 3/8-16
212	P0555212	FLAT WASHER 10MM
213	P0555213	STAND FOOT



Fence

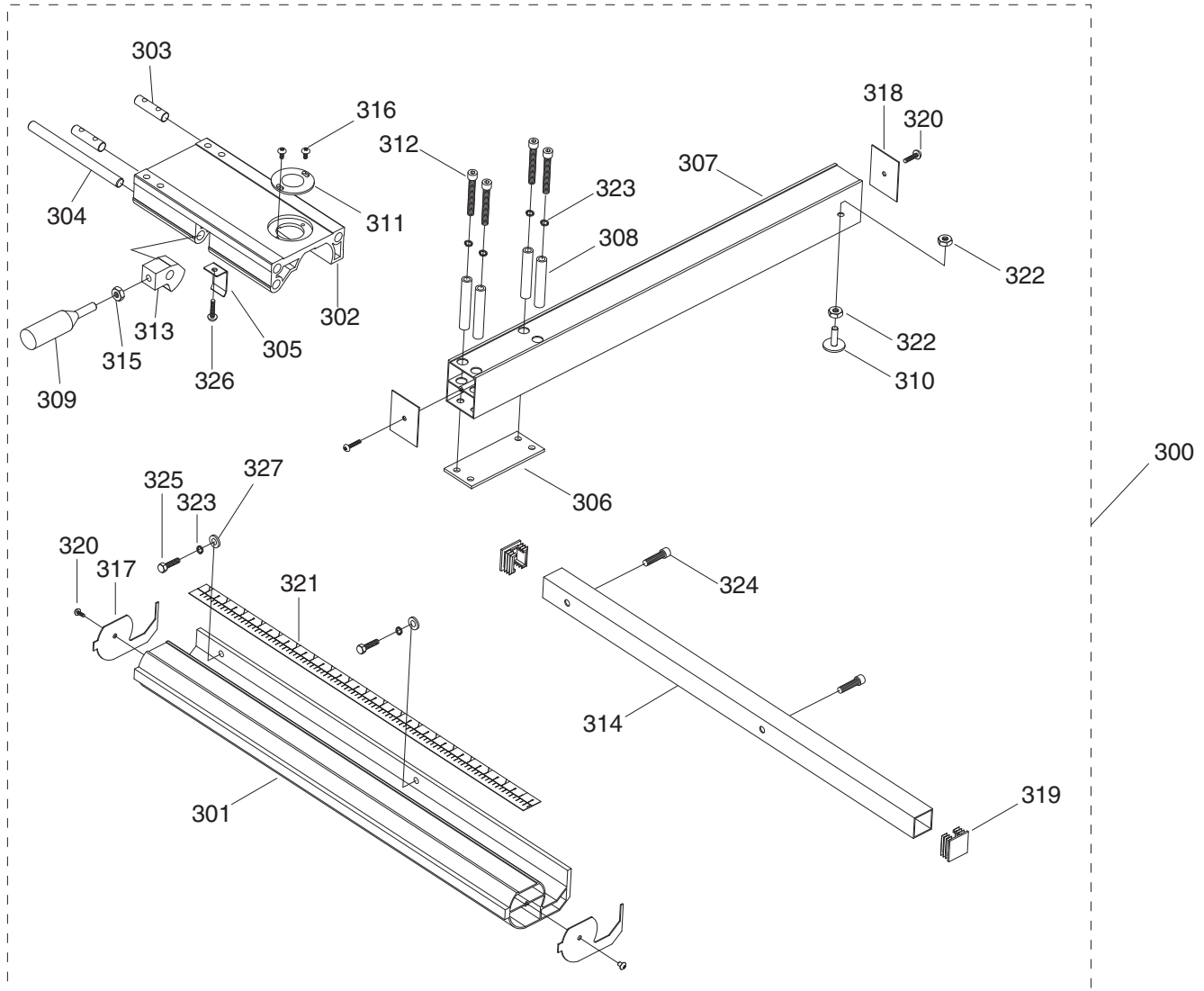

REF	PART #	DESCRIPTION
300	P0555300	FENCE KIT ASSEMBLY W/RAILS
301	P0555301	FRONT FENCE RAIL
302	P0555302	FENCE BASE
303	P0555303	FENCE MOUNT ROD
304	P0555304	LOCK SHAFT
305	P0555305	SPRING PLATE
306	P0555306	SPACER PLATE
307	P0555307	FENCE
308	P0555308	SLEEVE
309	P0555309	LOCK HANDLE
310	P0555310	FENCE STAND-OFF
311	P0555311	SCALE WINDOW
312	P0555312	CAP SCREW M6-1 X 60
313	P0555313	LOCK CAM

REF	PART #	DESCRIPTION
314	P0555314	REAR FENCE RAIL
315	P0555315	HEX NUT M6-1
316	P0555316	FLANGE SCREW M4-.7 X 6
317	P0555317	FRONT RAIL END CAP
318	P0555318	FENCE END CAP
319	P0555319	REAR RAIL END CAP
320	P0555320	TAP SCREW M3.5 X 8
321	P0555321	SCALE
322	P0555322	HEX NUT M6-1
323	P0555323	LOCK WASHER 6MM
324	P0555324	CAP SCREW M6-1 X 16
325	P0555325	HEX BOLT M6-1 X 20
326	P0555326	FLANGE SCREW M4-.7 X 8
327	P0555327	FLAT WASHER 6MM



Labels & Cosmetics

Grizzly Industrial MODEL G0555 ULTIMATE 14" BANDSAW

Specifications

Motor: 1 HP, 110V/220V, 1-Phase, 60 Hz
 Rated Voltage: 110V
 Full Load Amps: 11A (110V); 5.5A (220V)
 Table Size: 14" x 14"
 Blade Speeds: 1600, 2665 FPM
 Blade Length Range: 95-102" - 93-102"
 Blade Width Range: 1/8" - 3/4"
 Max. Cutting Width Left of Blade: 13-1/2"
 Max. Cutting Height: 6"
 Table Tilt: 15° L / 45° R
 Weight: 190 lbs.

WARNING!

To reduce risk of serious injury when using this machine:

1. Read & understand owner's manual before operating.
2. Never touch moving blade & keep hands out of blade path.
3. Always wear approved eye protection and respirator.
4. Only remove personal cutoff pieces when blade is stopped.
5. Use push stick or holding jig to cut small or narrow pieces.
6. Turn motor OFF and disconnect power before changing blades, making adjustments, or servicing.
7. Maintain adjustment of blade tension, tracking, & guides.
8. Keep upper guide adjusted to just clear the workpiece.
9. Hold workpiece firmly against table to maintain control.
10. Only run saw with wheel covers closed & all guards in place.
11. Never reach under table while blade is in motion.
12. Securely remove loose clothing and long hair.
13. DO NOT operate in rain or use in wet locations.
14. Prevent unauthorized use by children or untrained users; restrict access or disable machine when unattended.

144V2

146

G0555

148V2

NOTICE

The blade was purposely left untensioned for shipping purposes. Make sure you properly tension the blade (see manual) before starting this bandsaw!

158

145V2

WARNING!

EYE/LUNG INJURY HAZARD!
 Always wear safety glasses and a respirator when using this machine.



149

WARNING!

To reduce risk of death or serious injury, read manual **BEFORE** using machine.

To get a new manual, call (800) 523-4777 or go to www.grizzly.com.

WARNING!

INJURY HAZARD!
 Do not open door while machine is connected to power or blade is in motion.

148

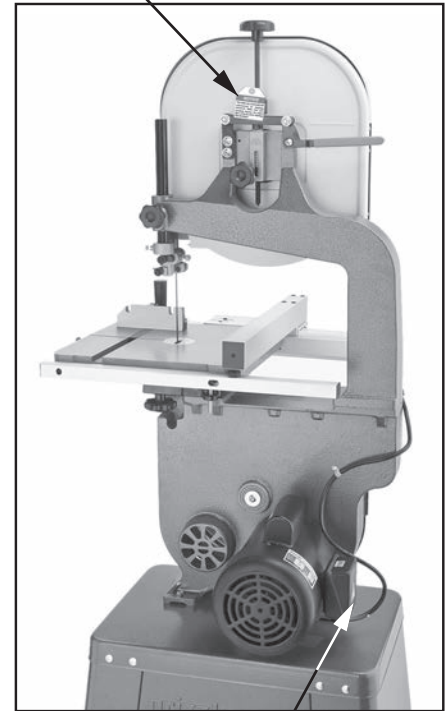

149



155

WARNING!

INJURY/SHOCK HAZARD!
 Disconnect power before adjustments, maintenance, or service.

147

157

156

REF	PART #	DESCRIPTION
144V2	P0555144V2	MACHINE ID LABEL V2.05.11
145V2	P0555145	GLASSES/RESPIRATOR LABEL V2.07.13
146	P0555146	MODEL NUMBER LABEL
147	P0555147	DISCONNECT POWER LABEL
148	P0555148	BANDSAW DOOR LABEL
148V2	P0555148V2	READ MANUAL LABEL

REF	PART #	DESCRIPTION
149	P0555149	ELECTRICITY LABEL
155	P0555155	GRIZZLY NAMEPLATE
156	P0555156	TOUCH-UP PAINT GRIZZLY GREEN
157	P0555157	TOUCH-UP PAINT GRIZZLY PUTTY
158	P0555158	BLADE TENSION NOTICE TAG

WARNING

Safety labels help reduce the risk of serious injury caused by machine hazards. If any label comes off or becomes unreadable, the owner of this machine **MUST** replace it in the original location before resuming operations. For replacements, contact (800) 523-4777 or www.grizzly.com.



WARRANTY & RETURNS

Grizzly Industrial, Inc. warrants every product it sells for a period of **1 year** to the original purchaser from the date of purchase. This warranty does not apply to defects due directly or indirectly to misuse, abuse, negligence, accidents, repairs or alterations or lack of maintenance. This is Grizzly's sole written warranty and any and all warranties that may be implied by law, including any merchantability or fitness, for any particular purpose, are hereby limited to the duration of this written warranty. We do not warrant or represent that the merchandise complies with the provisions of any law or acts unless the manufacturer so warrants. In no event shall Grizzly's liability under this warranty exceed the purchase price paid for the product and any legal actions brought against Grizzly shall be tried in the State of Washington, County of Whatcom.

We shall in no event be liable for death, injuries to persons or property or for incidental, contingent, special, or consequential damages arising from the use of our products.

The manufacturers reserve the right to change specifications at any time because they constantly strive to achieve better quality equipment. We make every effort to ensure that our products meet high quality and durability standards and we hope you never need to use this warranty.

In the event you need to use this warranty, contact us by mail or phone and give us all the details. We will then issue you a "Return Number," which must be clearly posted on the outside as well as the inside of the carton. We will not accept any item back without this number. Proof of purchase must accompany the merchandise.

Please feel free to write or call us if you have any questions about the machine or the manual.

Thank you again for your business and continued support. We hope to serve you again soon.

For further information about the warranty, visit <https://www.grizzly.com/forms/warranty> or scan the QR code below to be automatically directed to our warranty page.



grizzly.com[®]
TOOL WEBSITE

Buy Direct and Save with Grizzly[®] – Trusted, Proven and a Great Value!
~Since 1983~

*Visit Our Website Today For
Current Specials!*

**ORDER
24 HOURS A DAY!
1-800-523-4777**

