

READ THIS FIRST



Model G0459

*****IMPORTANT UPDATE*****

For Machines Mfd. Since 02/26
and Owner's Manual Revised 03/13

For questions or help with this product contact Tech Support at (570) 546-9663 or techsupport@grizzly.com

The following changes were recently made since the owner's manual was printed:

- Top cover and rear brace have changed.

Aside from this information, all other content in the owner's manual applies and **MUST** be read and understood for your own safety. **IMPORTANT: Keep this update with the owner's manual for future reference.**

For questions or help, contact our Tech Support at (570) 546-9663 or techsupport@grizzly.com.

Revised Parts

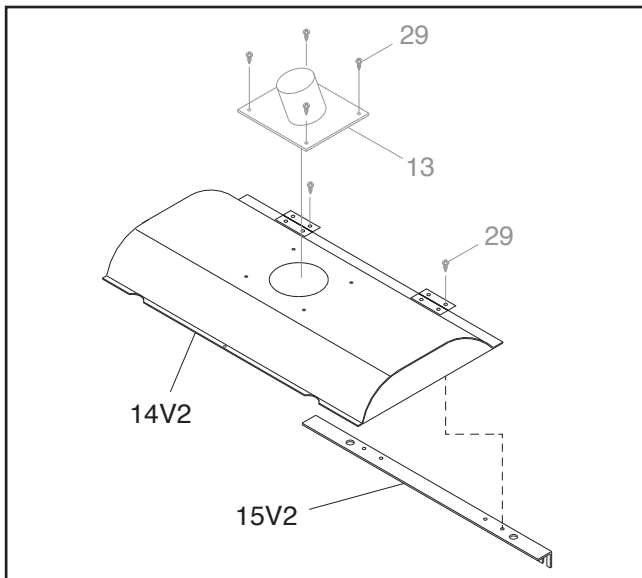

REF	PART #	DESCRIPTION
14V2	P0459014V2	TOP COVER V2.02.26
15V2	P0459015V2	REAR BRACE V2.02.26



COPYRIGHT © JANUARY, 2026 BY GRIZZLY INDUSTRIAL, INC.
WARNING: NO PORTION OF THIS MANUAL MAY BE REPRODUCED IN ANY SHAPE OR FORM WITHOUT THE WRITTEN APPROVAL OF GRIZZLY INDUSTRIAL, INC.
#JP23889 PRINTED IN TAIWAN

READ THIS FIRST



Model G0459

*****IMPORTANT UPDATE*****

**For Machines Mfd. Since 06/25
and Owner's Manual Revised 07/14**

For questions or help with this product contact Tech Support at (570) 546-9663 or techsupport@grizzly.com

The following changes were recently made since the owner's manual was printed:

- Parts have changed.
- Lubrication steps have been added.

Aside from this information, all other content in the owner's manual applies and **MUST** be read and understood for your own safety. **IMPORTANT: Keep this update with the owner's manual for future reference.**

For questions or help, contact our Tech Support at (570) 546-9663 or techsupport@grizzly.com.

Revised Specifications

Electrical

Power Cord Length..... 72"

Items Needed

Qty

Phillips Head Screwdriver #2 1
Oil Can 1
Shop Rags..... As Needed

Revised Parts

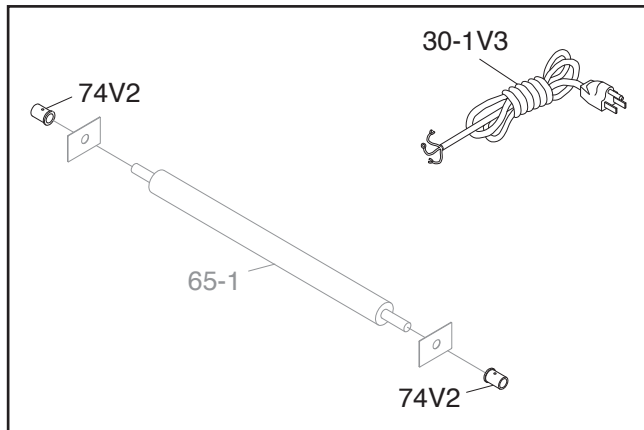

The conveyor roller bushings are located at each end of the front conveyor roller. These bushings require a small amount of machine oil daily to ensure smooth conveyor operation.

To lubricate the conveyor roller bushings, remove the front roller end guards and add 1–2 drops of machine oil to the lubrication hole in each bushing (see **Figure 1**). Wipe off excess oil to avoid sawdust buildup, then secure roller end guards.

REF	PART #	DESCRIPTION
30-1V3	P0459030-1V3	POWER CORD 14G 3W 72" V3.06.25
74V2	P0459074V2	BUSHING V2.06.25

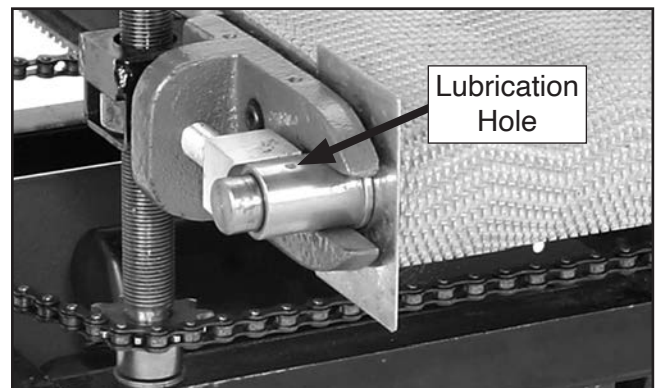

Figure 1. Location of conveyor roller bushing lubrication hole.

Revised Lubrication

Conveyor Roller Bushings

Lube Type..... SB1365 or ISO-68 Equivalent
Lube Amount 1–2 Drops
Lube Frequency Daily

COPYRIGHT © APRIL, 2025 BY GRIZZLY INDUSTRIAL, INC.
WARNING: NO PORTION OF THIS MANUAL MAY BE REPRODUCED IN ANY SHAPE OR FORM WITHOUT THE WRITTEN APPROVAL OF GRIZZLY INDUSTRIAL, INC.
#JP23565 PRINTED IN TAIWAN

Grizzly *Industrial, Inc.*®

MODEL G0459/G0459P 12" DRUM SANDER OWNER'S MANUAL



COPYRIGHT © OCTOBER, 2005 BY GRIZZLY INDUSTRIAL, INC. REVISED JULY, 2014 (ST)
**WARNING: NO PORTION OF THIS MANUAL MAY BE REPRODUCED IN ANY SHAPE
OR FORM WITHOUT THE WRITTEN APPROVAL OF GRIZZLY INDUSTRIAL, INC.**
(FOR MODELS MANUFACTURED SINCE 7/11) #BL7307 PRINTED IN TAIWAN



WARNING!

This manual provides critical safety instructions on the proper setup, operation, maintenance, and service of this machine/tool. Save this document, refer to it often, and use it to instruct other operators.

Failure to read, understand and follow the instructions in this manual may result in fire or serious personal injury—including amputation, electrocution, or death.

The owner of this machine/tool is solely responsible for its safe use. This responsibility includes but is not limited to proper installation in a safe environment, personnel training and usage authorization, proper inspection and maintenance, manual availability and comprehension, application of safety devices, cutting/sanding/grinding tool integrity, and the usage of personal protective equipment.

The manufacturer will not be held liable for injury or property damage from negligence, improper training, machine modifications or misuse.



WARNING!

Some dust created by power sanding, sawing, grinding, drilling, and other construction activities contains chemicals known to the State of California to cause cancer, birth defects or other reproductive harm. Some examples of these chemicals are:

- **Lead from lead-based paints.**
- **Crystalline silica from bricks, cement and other masonry products.**
- **Arsenic and chromium from chemically-treated lumber.**

Your risk from these exposures varies, depending on how often you do this type of work. To reduce your exposure to these chemicals: Work in a well ventilated area, and work with approved safety equipment, such as those dust masks that are specially designed to filter out microscopic particles.

Table of Contents

INTRODUCTION	2	SECTION 6: MAINTENANCE	25
Manual Accuracy	2	Schedule	25
Contact Info.....	2	Cleaning.....	25
Machine Description	2	Lubrication	25
Identification.....	3	SECTION 7: SERVICE	27
Machine Data Sheet	4	Troubleshooting	27
SECTION 1: SAFETY	8	Gauge Blocks.....	30
Safety Instructions for Machinery	8	V-Belt Service	30
Additional Safety for Drum Sanders	10	Conveyor Tensioning & Tracking.....	32
SECTION 2: POWER SUPPLY	11	Drum Adjustments	33
SECTION 3: SETUP	13	Pressure Roller Height.....	35
Needed for Setup.....	13	Scale Pointer Calibration	36
Unpacking	13	Table Lift Screws	37
Inventory	13	Conveyor Belt Replacement.....	38
Site Considerations.....	14	Changing Motor Brushes	42
Mounting	15	SECTION 8: WIRING	43
Installing Crank Handle.....	15	Wiring Safety Instructions	43
Dust Collection.....	16	Electrical Components	44
Power Connection.....	16	Wiring Diagram	45
Test Run	17	SECTION 9: PARTS	46
Recommended Adjustments.....	17	Frame.....	46
SECTION 4: OPERATIONS	18	Frame Parts List	47
Operation Overview	18	Drum	48
Basic Controls.....	19	Conveyor.....	49
Disabling & Locking Switch.....	19	Conveyor Parts List	50
Sanding Tips.....	20	Label Placement	50
Stock Inspection and Requirements	20	WARRANTY AND RETURNS	53
Depth of Cut.....	21		
Variable Speed	22		
Sanding.....	22		
Choosing Sandpaper	23		
Paper Replacement	23		
SECTION 5: ACCESSORIES	24		

INTRODUCTION

Manual Accuracy

We are proud to offer this manual with your new machine! We've made every effort to be exact with the instructions, specifications, drawings, and photographs of the machine we used when writing this manual. However, sometimes errors do happen and we apologize for them.

Also, owing to our policy of continuous improvement, **your machine may not exactly match the manual**. If you find this to be the case, and the difference between the manual and machine leaves you in doubt, check our website for the latest manual update or call technical support for help.

Before calling, find the manufacture date of your machine by looking at the date stamped into the machine ID label (see below). This will help us determine if the manual version you received matches the manufacture date of your machine.

		MODEL GXXXX MACHINE NAME	
SPECIFICATIONS		▲ WARNING!	
Motor:		Manufacture Date of Your Machine	ing this machine:
Specification:			operation.
Specification:			s and respirator.
Specification:			sted/setup and
Specification:			suit before starting.
Weight:		4. make sure the motor has stopped and disconnect	
	Date	power before adjustments, maintenance, or service.	
	Serial Number	5. DO NOT expose to rain or dampness.	
Manufactured for Grizzly in Taiwan		6. DO NOT modify this machine in any way.	
		7. DO NOT remove safety guards.	
		8. Never leave machine running unattended.	
		9. DO NOT operate under the influence of drugs or alcohol.	
		10. Maintain machine carefully to prevent accidents.	

For your convenience, we post all available manuals and manual updates for free on our website at www.grizzly.com. Any updates to your model of machine will be reflected in these documents as soon as they are complete.

Contact Info

We stand behind our machines. If you have any service questions, parts requests or general questions about the machine, please call or write us at the location listed below.

Grizzly Industrial, Inc.
1203 Lycoming Mall Circle
Muncy, PA 17756
Phone: (570) 546-9663
Fax: (800) 438-5901
E-Mail: techsupport@grizzly.com

If you have any comments regarding this manual, please write to us at the address below:

Grizzly Industrial, Inc.
c/o Technical Documentation Manager
P.O. Box 2069
Bellingham, WA 98227-2069
Email: manuals@grizzly.com

Machine Description

A drum sander is used to remove surface material from stock using an abrasive belt that is wrapped tightly around a drum.

A conveyor pulls the workpiece toward the sanding drum while pressure rollers hold the workpiece steady, so the sanding drum can remove a thin layer from the top of the workpiece.

On the G0459/G0459P, a crank handle is used to control cutting depth and a variable speed knob adjusts the conveyor speed for the specific type of workpiece and finish.

The only difference between the Model G0459 and G0459P is the paint color.



Identification

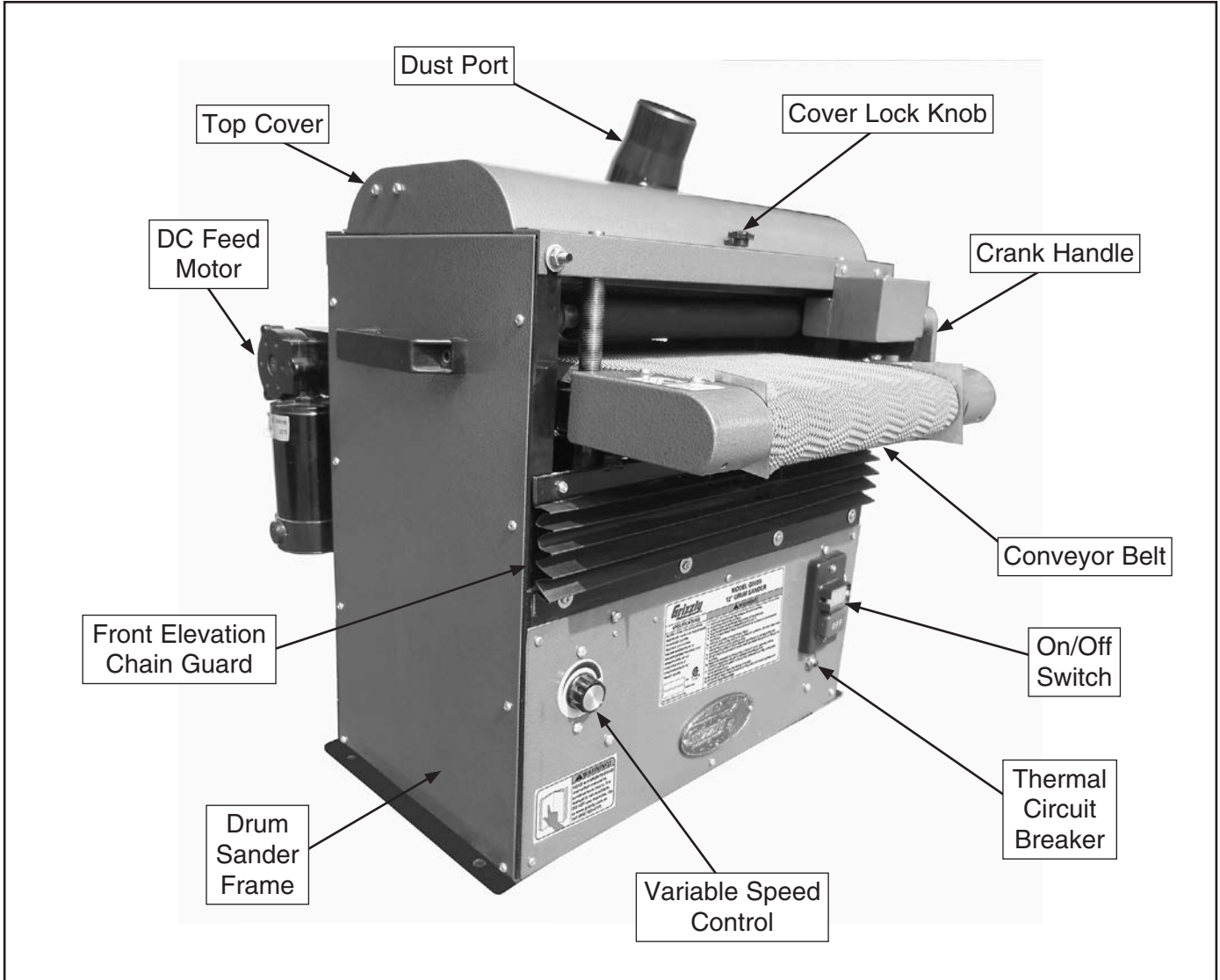

Figure 1. Front view, Model G0459.

	<p>⚠ WARNING To reduce the risk of serious injury when using this machine, read and understand this entire manual before beginning any operations.</p>
--	---





MACHINE DATA SHEET

Customer Service #: (570) 546-9663 · To Order Call: (800) 523-4777 · Fax #: (800) 438-5901

MODEL G0459 12" 1-1/2 HP BABY DRUM SANDER

Product Dimensions:

Weight..... 139 lbs.
 Width (side-to-side) x Depth (front-to-back) x Height..... 27 x 24 x 27 in.
 Footprint (Length x Width)..... 22-1/4 x 12 in.

Shipping Dimensions:

Type..... Cardboard Box
 Content..... Machine
 Weight..... 166 lbs.
 Length x Width x Height..... 26 x 27 x 27 in.
 Must Ship Upright..... Yes

Electrical:

Power Requirement..... 115V, Single-Phase, 60 Hz
 Prewired Voltage..... 115V
 Full-Load Current Rating..... 13.3A
 Minimum Circuit Size..... 15A
 Connection Type..... Cord & Plug
 Power Cord Included..... Yes
 Power Cord Length..... 11 ft.
 Power Cord Gauge..... 14 AWG
 Plug Included..... Yes
 Included Plug Type..... 5-15
 Switch Type..... ON/OFF Push Button Switch

Motors:

Feed

Horsepower..... 1/8 HP
 Phase..... Single-Phase
 Amps..... 0.3A
 Speed..... 5 – 55 RPM
 Type..... Universal
 Power Transfer..... Direct Drive
 Bearings..... Sealed & Permanently Lubricated
 Centrifugal Switch/Contacts Type..... N/A

Main

Horsepower..... 1.5 HP
 Phase..... Single-Phase
 Amps..... 13A
 Speed..... 3450 RPM
 Type..... TEFC Capacitor-Start Induction
 Power Transfer..... V-Belt Drive
 Bearings..... Sealed & Permanently Lubricated
 Centrifugal Switch/Contacts Type..... External



Main Specifications:

Operation Information

Number of Sanding Heads.....	1
Maximum Board Width.....	12 in.
Minimum Board Width.....	2 in.
Maximum Board Thickness.....	3-1/2 in.
Minimum Board Thickness.....	1/8 in.
Minimum Board Length.....	8 in.
Sandpaper Speed.....	2127 FPM
Conveyor Feed Rate.....	2.5 – 17.3 FPM
Sandpaper Length.....	70 in.
Sandpaper Width.....	3 in.

Drum Information

Infeed Sanding Drum Type.....	Aluminum
Infeed Sanding Drum Size.....	4 in.

Construction

Conveyor Belt.....	Rubber
Body.....	Steel
Paint Type/Finish.....	Powder Coated

Other Related Information

Sanding Belt Tension.....	Hook & Loop
Number of Pressure Rollers.....	2
Pressure Roller Type.....	Rubber
Pressure Roller Size.....	1-3/8 in.
Conveyor Belt Length.....	49-3/4 in.
Conveyor Belt Width.....	12-1/4 in.
Number of Dust Ports.....	1
Dust Port Size.....	2-1/2 in.

Other Specifications:

Country of Origin	Taiwan
Warranty	1 Year
Approximate Assembly & Setup Time	15 Minutes
Serial Number Location	ID Label
ISO 9001 Factory	No
Certified by a Nationally Recognized Testing Laboratory (NRTL)	Yes

Features:

- Hoop & Loop Sanding Belt Tension/Sandpaper
- Industrial-Duty Rubber Conveyor Belt
- 2-1/2" Dust Port
- Variable Speed Conveyor
- V-Belt Main Motor; Direct Drive Feed Motor
- 4" Aluminum Sanding Drum
- Green Powder Coated Paint
- Steel Dust Scoop Maximizes Dust Collection Efficiency
- Two Adjustable Pressure Rollers
- Thickness Scale
- Welded Steel Construction
- Side Handles for Portability





MACHINE DATA SHEET

Customer Service #: (570) 546-9663 · To Order Call: (800) 523-4777 · Fax #: (800) 438-5901

MODEL G0459P 12" BABY DRUM SANDER, POLAR BEAR SERIES

Product Dimensions:

Weight..... 139 lbs.
 Width (side-to-side) x Depth (front-to-back) x Height..... 27 x 24 x 27 in.
 Footprint (Length x Width)..... 22-1/4 x 12 in.

Shipping Dimensions:

Type..... Cardboard Box
 Content..... Machine
 Weight..... 166 lbs.
 Length x Width x Height..... 27 x 26 x 27 in.
 Must Ship Upright..... Yes

Electrical:

Power Requirement..... 115V, Single-Phase, 60 Hz
 Prewired Voltage..... 115V
 Full-Load Current Rating..... 13.3A
 Minimum Circuit Size..... 15A
 Connection Type..... Cord & Plug
 Power Cord Included..... Yes
 Power Cord Length..... 11 ft.
 Power Cord Gauge..... 14 AWG
 Plug Included..... Yes
 Included Plug Type..... 5-15
 Switch Type..... ON/OFF Push Button Switch

Motors:

Feed

Horsepower..... 1/8 HP
 Phase..... Single-Phase
 Amps..... 0.3A
 Speed..... 5 – 55 RPM
 Type..... Universal
 Power Transfer Direct Drive
 Bearings..... Sealed & Permanently Lubricated
 Centrifugal Switch/Contacts Type..... N/A

Main

Horsepower..... 1.5 HP
 Phase..... Single-Phase
 Amps..... 13A
 Speed..... 3450 RPM
 Type..... TEFC Capacitor-Start Induction
 Power Transfer V-Belt Drive
 Bearings..... Sealed & Permanently Lubricated
 Centrifugal Switch/Contacts Type..... External



Main Specifications:

Operation Information

Number of Sanding Heads.....	1
Maximum Board Width.....	12 in.
Minimum Board Width.....	2 in.
Maximum Board Thickness.....	3-1/2 in.
Minimum Board Thickness.....	1/8 in.
Minimum Board Length.....	8 in.
Sandpaper Speed.....	2127 FPM
Conveyor Feed Rate.....	2.5 – 17.3 FPM
Sandpaper Length.....	70 in.
Sandpaper Width.....	3 in.

Drum Information

Infeed Sanding Drum Type.....	Aluminum
Infeed Sanding Drum Size.....	4 in.

Construction

Conveyor Belt.....	Rubber
Body.....	Steel
Paint Type/Finish.....	Powder Coated

Other Related Information

Sanding Belt Tension.....	Hook & Loop
Number of Pressure Rollers.....	2
Pressure Roller Type.....	Rubber
Pressure Roller Size.....	1-3/8 in.
Conveyor Belt Length.....	49-3/4 in.
Conveyor Belt Width.....	12-1/4 in.
Number of Dust Ports.....	1
Dust Port Size.....	2-1/2 in.

Other Specifications:

Country of Origin	Taiwan
Warranty	1 Year
Approximate Assembly & Setup Time	15 Minutes
Serial Number Location	ID Label on Front
ISO 9001 Factory	No
Certified by a Nationally Recognized Testing Laboratory (NRTL)	Yes

Features:

- Hoop & Loop Sanding Belt Tension/Sandpaper
- Industrial-Duty Rubber Conveyor Belt
- 2-1/2" Dust Port
- Variable Speed Conveyor
- V-Belt Main Motor; Direct Drive Feed Motor
- 4" Aluminum Sanding Drum
- White Powder Coated Paint
- Steel Dust Scoop Maximizes Dust Collection Efficiency
- Two Adjustable Pressure Rollers
- Thickness Scale
- Welded Steel Construction
- Side Handles for Portability



SECTION 1: SAFETY

For Your Own Safety, Read Instruction Manual Before Operating This Machine

The purpose of safety symbols is to attract your attention to possible hazardous conditions. This manual uses a series of symbols and signal words intended to convey the level of importance of the safety messages. The progression of symbols is described below. Remember that safety messages by themselves do not eliminate danger and are not a substitute for proper accident prevention measures. Always use common sense and good judgment.

 **DANGER** Indicates an imminently hazardous situation which, if not avoided, **WILL** result in death or serious injury.

 **WARNING** Indicates a potentially hazardous situation which, if not avoided, **COULD** result in death or serious injury.

 **CAUTION** Indicates a potentially hazardous situation which, if not avoided, **MAY** result in minor or moderate injury. It may also be used to alert against unsafe practices.

NOTICE This symbol is used to alert the user to useful information about proper operation of the machine.

Safety Instructions for Machinery

WARNING

OWNER'S MANUAL. Read and understand this owner's manual **BEFORE** using machine.

TRAINED OPERATORS ONLY. Untrained operators have a higher risk of being hurt or killed. Only allow trained/supervised people to use this machine. When machine is not being used, disconnect power, remove switch keys, or lock-out machine to prevent unauthorized use—especially around children. Make workshop kid proof!

DANGEROUS ENVIRONMENTS. Do not use machinery in areas that are wet, cluttered, or have poor lighting. Operating machinery in these areas greatly increases the risk of accidents and injury.

MENTAL ALERTNESS REQUIRED. Full mental alertness is required for safe operation of machinery. Never operate under the influence of drugs or alcohol, when tired, or when distracted.

ELECTRICAL EQUIPMENT INJURY RISKS. You can be shocked, burned, or killed by touching live electrical components or improperly grounded machinery. To reduce this risk, only allow qualified service personnel to do electrical installation or repair work, and always disconnect power before accessing or exposing electrical equipment.

DISCONNECT POWER FIRST. Always disconnect machine from power supply **BEFORE** making adjustments, changing tooling, or servicing machine. This prevents an injury risk from unintended startup or contact with live electrical components.

EYE PROTECTION. Always wear ANSI-approved safety glasses or a face shield when operating or observing machinery to reduce the risk of eye injury or blindness from flying particles. Everyday eyeglasses are not approved safety glasses.



WARNING

WEARING PROPER APPAREL. Do not wear clothing, apparel or jewelry that can become entangled in moving parts. Always tie back or cover long hair. Wear non-slip footwear to avoid accidental slips, which could cause loss of workpiece control.

HAZARDOUS DUST. Dust created while using machinery may cause cancer, birth defects, or long-term respiratory damage. Be aware of dust hazards associated with each workpiece material, and always wear a NIOSH-approved respirator to reduce your risk.

HEARING PROTECTION. Always wear hearing protection when operating or observing loud machinery. Extended exposure to this noise without hearing protection can cause permanent hearing loss.

REMOVE ADJUSTING TOOLS. Tools left on machinery can become dangerous projectiles upon startup. Never leave chuck keys, wrenches, or any other tools on machine. Always verify removal before starting!

INTENDED USAGE. Only use machine for its intended purpose and never make modifications not approved by Grizzly. Modifying machine or using it differently than intended may result in malfunction or mechanical failure that can lead to serious personal injury or death!

AWKWARD POSITIONS. Keep proper footing and balance at all times when operating machine. Do not overreach! Avoid awkward hand positions that make workpiece control difficult or increase the risk of accidental injury.

CHILDREN & BYSTANDERS. Keep children and bystanders at a safe distance from the work area. Stop using machine if they become a distraction.

GUARDS & COVERS. Guards and covers reduce accidental contact with moving parts or flying debris. Make sure they are properly installed, undamaged, and working correctly.

FORCING MACHINERY. Do not force machine. It will do the job safer and better at the rate for which it was designed.

NEVER STAND ON MACHINE. Serious injury may occur if machine is tipped or if the cutting tool is unintentionally contacted.

STABLE MACHINE. Unexpected movement during operation greatly increases risk of injury or loss of control. Before starting, verify machine is stable and mobile base (if used) is locked.

USE RECOMMENDED ACCESSORIES. Consult this owner's manual or the manufacturer for recommended accessories. Using improper accessories will increase the risk of serious injury.

UNATTENDED OPERATION. To reduce the risk of accidental injury, turn machine **OFF** and ensure all moving parts completely stop before walking away. Never leave machine running while unattended.

MAINTAIN WITH CARE. Follow all maintenance instructions and lubrication schedules to keep machine in good working condition. A machine that is improperly maintained could malfunction, leading to serious personal injury or death.

CHECK DAMAGED PARTS. Regularly inspect machine for any condition that may affect safe operation. Immediately repair or replace damaged or mis-adjusted parts before operating machine.

MAINTAIN POWER CORDS. When disconnecting cord-connected machines from power, grab and pull the plug—NOT the cord. Pulling the cord may damage the wires inside. Do not handle cord/plug with wet hands. Avoid cord damage by keeping it away from heated surfaces, high traffic areas, harsh chemicals, and wet/damp locations.

EXPERIENCING DIFFICULTIES. If at any time you experience difficulties performing the intended operation, stop using the machine! Contact our Technical Support at (570) 546-9663.



WARNING

Additional Safety for Drum Sanders

FEEDING STOCK. Do not stand in the direct path of a workpiece at the infeed end when feeding your stock. Never sand more than one piece of stock at a time. DO NOT jam the workpiece into the machine during operation. Firmly grasp the workpiece in both hands and ease it into the machine using light pressure.

MINIMUM STOCK DIMENSIONS. Do not sand any stock thinner than $\frac{1}{8}$ ", narrower than 2", or shorter than 8". Do not sand thin stock by using a "dummy" board under your workpiece.

SAFETY COVERS. All covers must be closed and in place before starting machine.

CLOTHING. Do not wear loose clothing while operating this machine. Roll up or button long sleeves at the cuff.

HAND PROTECTION. Do not place hands near, or in contact with, sanding drum during operation. DO NOT allow fingers to get pinched between board and conveyor belt during operation. This may pull the operator's hand into the machine and cause serious injury!

DUST COLLECTION SYSTEM. Never operate the sander without an adequate dust collection system in place and running.

INSPECTING WORKPIECES. Always inspect every workpiece for nails, staples, knots, and other imperfections that could be dislodged and thrown from the machine during sanding operations. Do not use workpieces with these defects.

EXPERIENCING DIFFICULTIES. Any problem, with the exception of conveyor belt tracking, that is concerned with any moving parts or accessories, must be investigated and corrected with the power disconnected, and after all moving parts have come to a complete stop.

MAINTENANCE AND ADJUSTMENTS. Never attempt to adjust conveyor belt tracking when the sanding drum is running.

Perform machine inspections and maintenance service promptly when called for. Disconnect power before performing maintenance or adjustments to the sander.

RESPIRATOR AND SAFETY GLASSES. Always wear a respirator and safety glasses while operating the machine. Dust and chips are created when sanding. Some debris will be ejected, becoming hazards to the eyes and lungs.



SECTION 2: POWER SUPPLY

Availability

Before installing the machine, consider the availability and proximity of the required power supply circuit. If an existing circuit does not meet the requirements for this machine, a new circuit must be installed. To minimize the risk of electrocution, fire, or equipment damage, installation work and electrical wiring must be done by an electrician or qualified service personnel in accordance with all applicable codes and standards.

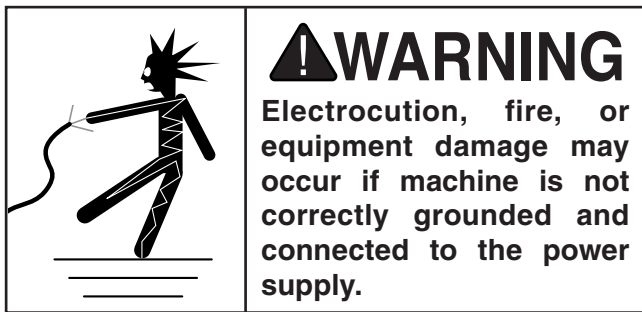

Full-Load Current Rating

The full-load current rating is the amperage a machine draws at 100% of the rated output power. On machines with multiple motors, this is the amperage drawn by the largest motor or sum of all motors and electrical devices that might operate at one time during normal operations.

Full-Load Current Rating at 115V... 13.3 Amps

The full-load current is not the maximum amount of amps that the machine will draw. If the machine is overloaded, it will draw additional amps beyond the full-load rating.

If the machine is overloaded for a sufficient length of time, damage, overheating, or fire may result—especially if connected to an undersized circuit. To reduce the risk of these hazards, avoid overloading the machine during operation and make sure it is connected to a power supply circuit that meets the requirements in the following section.

Circuit Requirements

This machine is prewired to operate on a power supply circuit that has a verified ground and meets the following requirements:

Nominal Voltage 115V
Cycle 60 Hz
Phase Single-Phase
Power Supply Circuit 15 Amps

A power supply circuit includes all electrical equipment between the breaker box or fuse panel in the building and the machine. The power supply circuit used for this machine must be sized to safely handle the full-load current drawn from the machine for an extended period of time. (If this machine is connected to a circuit protected by fuses, use a time delay fuse marked D.)



Note: *The circuit requirements listed in this manual apply to a dedicated circuit—where only one machine will be running at a time. If this machine will be connected to a shared circuit where multiple machines will be running at the same time, consult a qualified electrician to ensure that the circuit is properly sized for safe operation.*



Grounding & Plug Requirements

This machine **MUST** be grounded. In the event of certain malfunctions or breakdowns, grounding reduces the risk of electric shock by providing a path of least resistance for electric current.

This machine is equipped with a power cord that has an equipment-grounding wire and a grounding plug (similar to the figure below). The plug must only be inserted into a matching receptacle (outlet) that is properly installed and grounded in accordance with all local codes and ordinances.

⚠ WARNING

Serious injury could occur if you connect the machine to power before completing the setup process. DO NOT connect to power until instructed later in this manual.

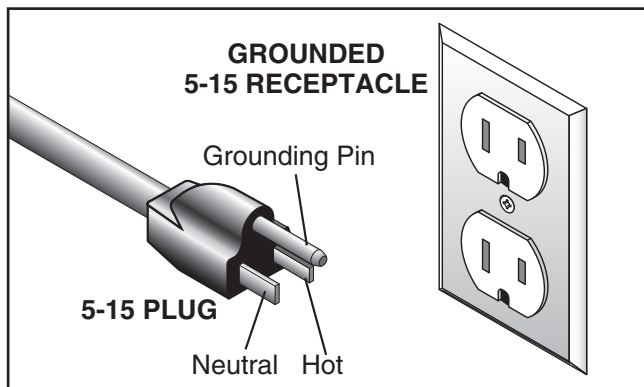

Figure 2. Typical 5-15 plug and receptacle.

⚠ CAUTION

SHOCK HAZARD!

Two-prong outlets do not meet the grounding requirements for this machine. Do not modify or use an adapter on the plug provided—if it will not fit the outlet, have a qualified electrician install the proper outlet with a verified ground.

Improper connection of the equipment-grounding wire can result in a risk of electric shock. The wire with green insulation (with or without yellow stripes) is the equipment-grounding wire. If repair or replacement of the power cord or plug is necessary, do not connect the equipment-grounding wire to a live (current carrying) terminal.

Check with a qualified electrician or service personnel if you do not understand these grounding requirements, or if you are in doubt about whether the tool is properly grounded. If you ever notice that a cord or plug is damaged or worn, disconnect it from power, and immediately replace it with a new one.

Extension Cords

We do not recommend using an extension cord with this machine. If you must use an extension cord, only use it if absolutely necessary and only on a temporary basis.

Extension cords cause voltage drop, which may damage electrical components and shorten motor life. Voltage drop increases as the extension cord size gets longer and the gauge size gets smaller (higher gauge numbers indicate smaller sizes).

Any extension cord used with this machine must contain a ground wire, match the required plug and receptacle, and meet the following requirements:

- Minimum Gauge Size 14 AWG**
- Maximum Length (Shorter is Better)..... 50 ft.**



SECTION 3: SETUP

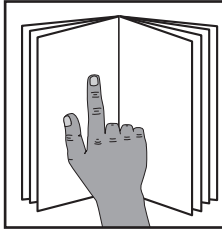

!WARNING

To reduce your risk of serious injury, read this entire manual **BEFORE** using machine.



!WARNING

Wear safety glasses during the entire setup process!



!WARNING

This machine and its components are very heavy. Get lifting help or use power lifting equipment such as a forklift to move heavy items.

Needed for Setup

The following are needed to complete the setup process, but are not included with your machine.

Description	Qty
• Safety Glasses	1
• Additional People	1
• Screwdriver Phillips #2	1
• Dust Collection System	1
• Dust Hose 2½"	1
• Hose Clamps 2½"	2
• Lag Bolts 5/16-18 x 40 (Not Included)	4
• Open End Wrench or Socket ½"	1
• Drill	1
• Drill Bit ¼"	1

Unpacking

Your machine was carefully packaged for safe transportation. Remove the packaging materials from around your machine and inspect it. If you discover any damage, *please call us immediately at (570) 546-9663 for advice.*

Save the containers and all packing materials for possible inspection by the carrier or its agent. *Otherwise, filing a freight claim can be difficult.*

When you are completely satisfied with the condition of your shipment, inventory the contents.

Inventory

The following is a list of items shipped with your machine. Before beginning setup, lay these items out and inventory them.

If any non-proprietary parts are missing (e.g. a nut or a washer), we will gladly replace them; or for the sake of expediency, replacements can be obtained at your local hardware store.

Box 1: (Figure 3)	Qty
A. Drum Sander (not shown)	1
B. Crank Handle	1
C. Dust Port 2½"	1
D. Hex Wrench 3mm.....	1



Figure 3. G0459/G0459P Inventory.

NOTICE

If you cannot find an item on this list, carefully check around/inside the machine and packaging materials. Often, these items get lost in packaging materials while unpacking or they are pre-installed at the factory.



Site Considerations

Weight Load

Refer to the **Machine Data Sheet** for the weight of your machine. Make sure that the surface upon which the machine is placed will bear the weight of the machine, additional equipment that may be installed on the machine, and the heaviest workpiece that will be used. Additionally, consider the weight of the operator and any dynamic loading that may occur when operating the machine.

Space Allocation

Consider the largest size of workpiece that will be processed through this machine and provide enough space around the machine for adequate operator material handling or the installation of auxiliary equipment. With permanent installations, leave enough space around the machine to open or remove doors/covers as required by the maintenance and service described in this manual. **See below for required space allocation.**

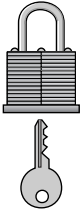
	<p>CAUTION Children or untrained people may be seriously injured by this machine. Only install in an access restricted location.</p>
---	---

Physical Environment

The physical environment where the machine is operated is important for safe operation and longevity of machine components. For best results, operate this machine in a dry environment that is free from excessive moisture, hazardous chemicals, airborne abrasives, or extreme conditions. Extreme conditions for this type of machinery are generally those where the ambient temperature range exceeds 41°–104°F; the relative humidity range exceeds 20–95% (non-condensing); or the environment is subject to vibration, shocks, or bumps.

Electrical Installation

Place this machine near an existing power source. Make sure all power cords are protected from traffic, material handling, moisture, chemicals, or other hazards. Make sure to leave access to a means of disconnecting the power source or engaging a lockout/tagout device, if required.

Lighting

Lighting around the machine must be adequate enough that operations can be performed safely. Shadows, glare, or strobe effects that may distract or impede the operator must be eliminated.

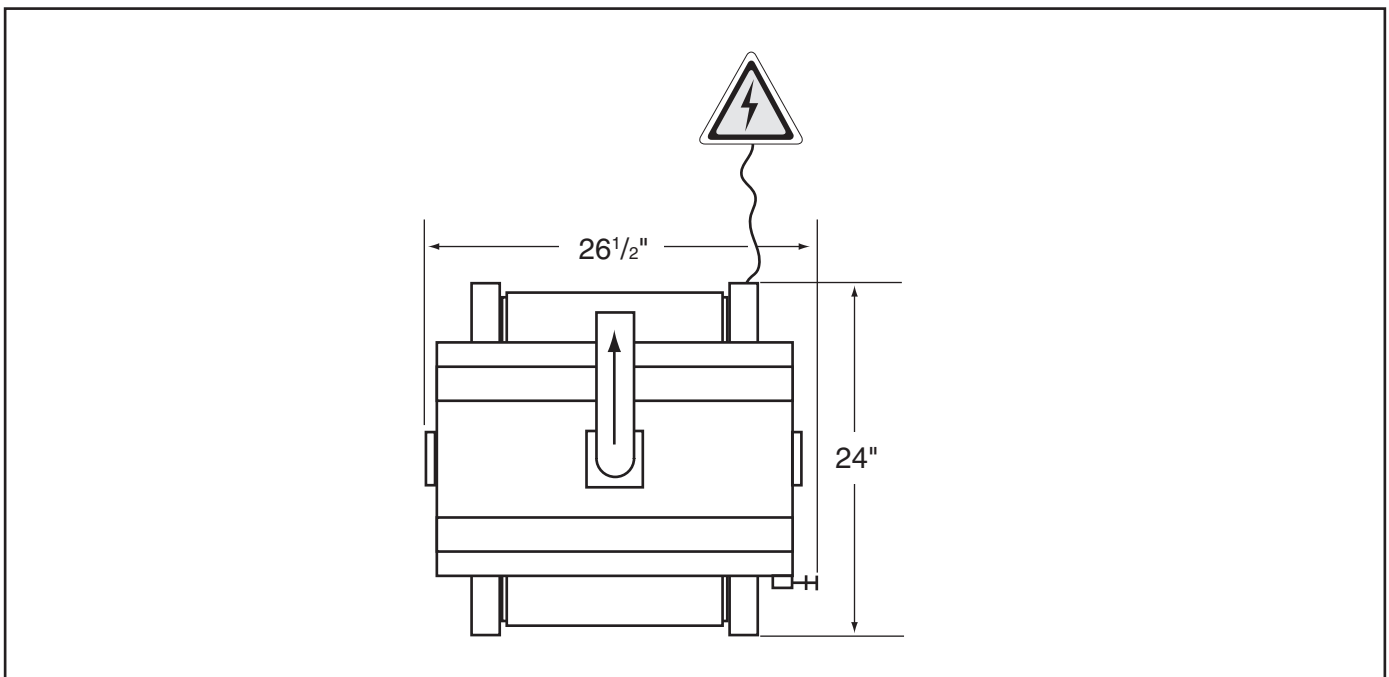

Figure 4. Minimum working clearances.



Mounting

The base of this machine has holes that allow it to be mounted to a workbench. We strongly recommend that you mount your machine to a workbench to prevent it from moving during operation. An unexpected movement could result in an injury or property damage.

The strongest mounting option is a "Through Mount" where holes are drilled all the way through the workbench, and hex bolts, washers, and hex nuts are used to secure the drum sander to the workbench.

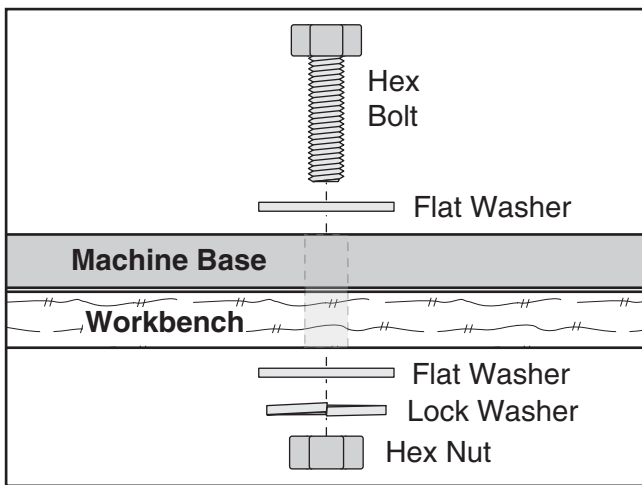

Figure 5. Example of a through mount setup.

Another option for mounting is a "Direct Mount" where the machine is simply secured to the workbench with a lag screw.

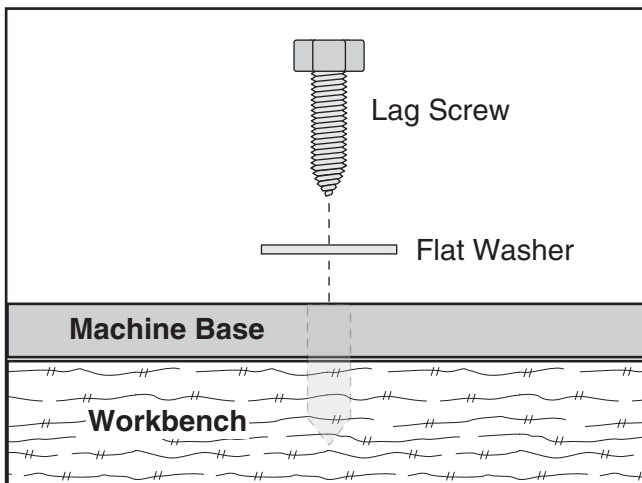

Figure 6. Example of a direct mount setup.

Installing Crank Handle

Components and Hardware Needed:	Qty
Crank Handle	1

The crank handle is installed on the front right lift screw shaft, and is held in place with two set screws already threaded into the handle.

To mount the handwheel, place the crank handle over the shaft shown in **Figure 7** and, using a 3mm hex wrench, secure the handle with the two set screws.

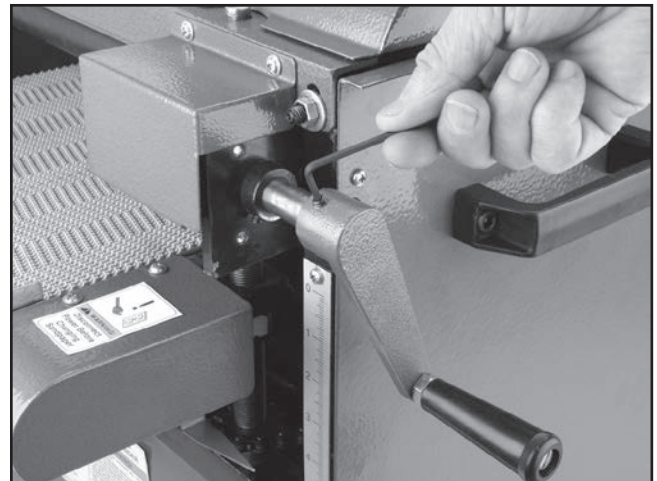

Figure 7. Crank handle installation.



Dust Collection

CAUTION

DO NOT operate the Model G0459/G0459P without an adequate dust collection system. This sander creates substantial amounts of wood dust while operating. Failure to use a dust collection system can result in short and long-term respiratory illness.

Recommended CFM at Dust Port: 150 CFM

Do not confuse this CFM recommendation with the rating of the dust collector. To determine the CFM at the dust port, you must consider these variables: (1) CFM rating of the dust collector, (2) hose type and length between the dust collector and the machine, (3) number of branches or wyes, and (4) amount of other open lines throughout the system. Explaining how to calculate these variables is beyond the scope of this manual. Consult an expert or purchase a good dust collection "how-to" book.

To connect a dust collection hose:

1. Remove the four Phillips head screws at the dust port hole.
2. Place the 2½" dust port over the top cover mounting holes and secure with the screws removed in **Step 1** (see **Figure 8**).

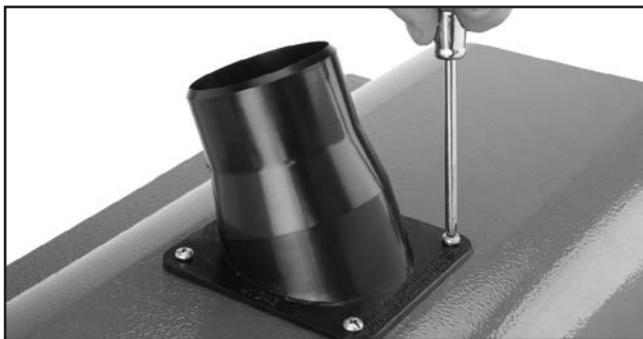

Figure 8. Dust port installation.

3. Fit a 2½" dust hose over the dust port and secure in place with a hose clamp.
4. Tug the hose to make sure it does not come off. **Note:** A tight fit is necessary for proper performance.

Power Connection

After you have completed all previous setup instructions and circuit requirements, the machine is ready to be connected to the power supply.

To avoid unexpected startups or property damage, use the following steps whenever connecting or disconnecting the machine.

Connecting Power

1. Turn the machine power switch **OFF**.
2. Insert the power cord plug into a matching power supply receptacle. The machine is now connected to the power source.

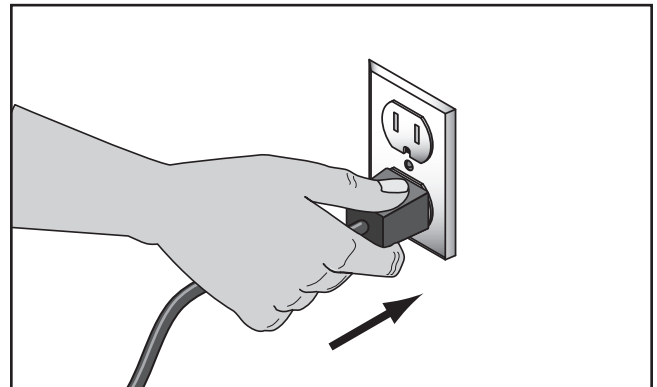

Figure 9. Connecting power.

Disconnecting Power

1. Turn the machine power switch **OFF**.
2. Grasp the molded plug and pull it completely out of the receptacle. Do not pull by the cord as this may damage the wires inside.

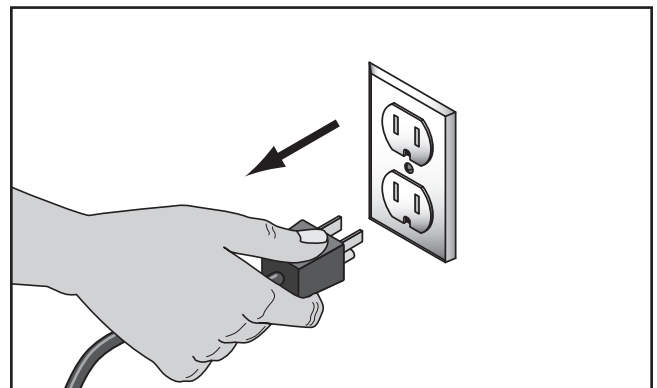

Figure 10. Disconnecting power.



Test Run

Once the assembly is complete, test run your machine to make sure it runs properly.

If, during the test run, you cannot easily locate the source of an unusual noise or vibration, stop using the machine immediately, then review the **Troubleshooting** on Manual **Page 23**.

If you still cannot remedy a problem, contact our Tech Support at (570) 546-9663 for assistance.

To test run the machine:

1. Make sure you have read the safety instructions at the beginning of the manual and that the machine is setup properly.
2. Make sure all tools and objects used during setup are cleared away from the machine.
3. Turn the machine **ON**, then rotate the variable speed knob clockwise to start the conveyor belt.
4. Listen to and watch for abnormal noises or actions. The machine should run smoothly with little or no vibration or rubbing noises.

—Strange or unusual noises should be investigated and corrected before operating the machine further. Always disconnect the machine from power when investigating or correcting potential problems.

5. Turn the machine **OFF**.

Recommended Adjustments

For your convenience, the adjustments listed below have been performed at the factory and no further setup is required to operate your machine.

However, because of the many variables involved with shipping, some of these adjustments may need to be repeated to ensure optimum results. Keep this in mind as you start to use your new drum sander.

Step-by-step instructions for these adjustments can be found in SECTION 7: SERVICE ADJUSTMENTS.

1. V-Belt Service (**Page 30**). Perform after the first 16 hours.
2. Conveyor Tensioning & Tracking (**Page 32**).
3. Drum Adjustments (**Page 33**).
4. Pressure Roller Height (**Page 35**).



SECTION 4: OPERATIONS

Operation Overview

The purpose of this overview is to provide the novice machine operator with a basic understanding of how the machine is used during operation, so the machine controls/components discussed later in this manual are easier to understand.

Due to the generic nature of this overview, it is **not** intended to be an instructional guide. To learn more about specific operations, read this entire manual and seek additional training from experienced machine operators, and do additional research outside of this manual by reading "how-to" books, trade magazines, or websites.

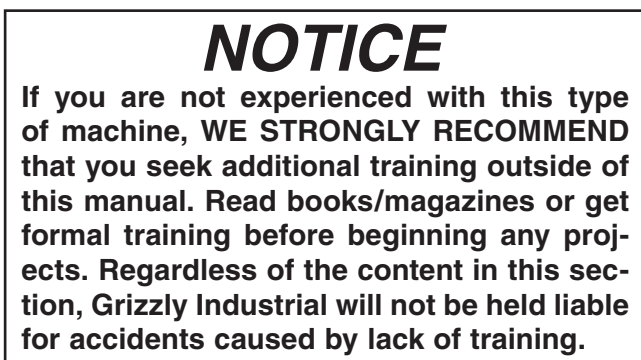
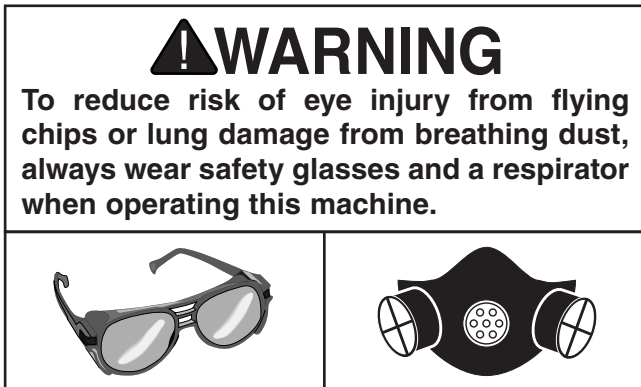

To complete a typical operation, the operator does the following:

1. Examines the workpiece to make sure it is suitable for sanding.
2. Places the workpiece on the conveyor table under or next to the front pressure roller, and adjusts the table height until the top surface of the workpiece just touches the front pressure roller.
3. Checks the outfeed side of the machine to make sure the workpiece can safely pass all the way through without interference from other objects.
4. Wears safety glasses and a respirator.
5. Starts the dust collector.
6. Turns the sander **ON**, adjusts conveyor speed, places the workpiece flat on the conveyor, then lets the conveyor feed the workpiece into the sander.
7. Slowly raises the conveyor table using the hand crank until the sandpaper begins sanding the workpiece.
8. Stands at the side of the sander and retrieves the workpiece from the outfeed end.
9. Stops the machine.



Basic Controls

Refer to **Figure 11** and the following descriptions to become familiar with the basic controls of this machine.

- A. Variable Speed Knob:** Adjusts feed rate from 2.47–17.3 FPM. Rotate clockwise to increase feed speed, rotate counterclockwise to decrease feed speed.
- B. Hand Crank:** Used to raise or lower the conveyor table to control depth of cut. Each full rotation of the hand crank raises or lowers the conveyor table approximately 0.027" (0.69 mm).
- C. On Button:** Turns motor **ON**.
- D. Off Button:** Turns motor **OFF**.

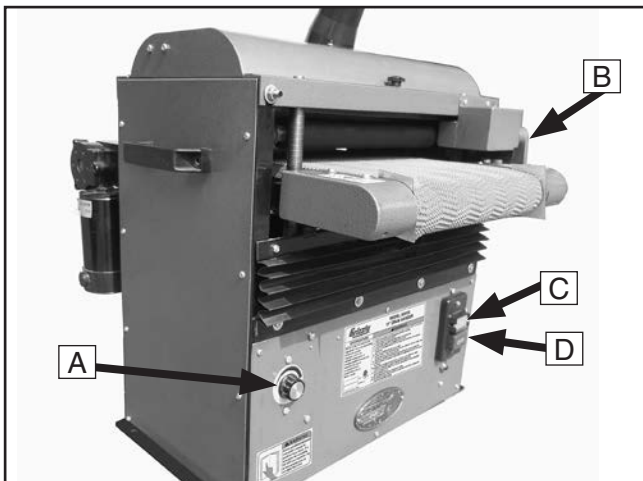

Figure 11. G0459/G0459P controls.

Disabling & Locking Switch

The ON/OFF switch can be disabled and locked by inserting a padlock through the ON button, as shown. Locking the switch in this manner can prevent unauthorized operation of the machine, which is especially important if the machine is not stored inside an access-restricted building.

IMPORTANT: Locking the switch with a padlock only restricts its function. It is not a substitute for disconnecting power from the machine when adjusting or servicing.

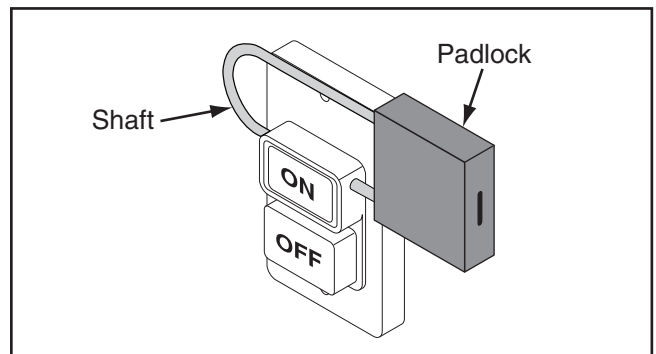

Figure 12. Switch disabled by a padlock.

⚠ WARNING

Children or untrained people can be seriously injured by this machine. This risk increases with unsupervised operation. To help prevent unsupervised operation, disable and lock the switch before leaving machine unattended! Place key in a well-hidden or secure location.

NOTICE

The padlock shaft diameter is important to the disabling function of the switch. With any padlock used to lock the switch, test the switch after installation to ensure that it is properly disabled.

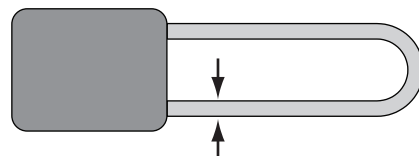

Figure 13. Minimum lock shaft requirements.



Sanding Tips

- Replace the sandpaper with a higher grit to achieve a finer finish.
- Raise the table with a maximum of $\frac{1}{4}$ turn of the crank handle until the workpiece is the desired thickness.
- Reduce snipe when sanding more than one board of the same thickness by feeding them into the sander with the front end of the second board touching the back end of the first board.
- Feed boards into the sander at different points on the conveyor to maximize sandpaper life and prevent uneven conveyor belt wear.
- DO NOT sand boards less than 8" long or less than $\frac{1}{8}$ " thick to prevent damage to the workpiece and the drum sander.
- Extend the life of the sandpaper by regularly using a PRO-STICK® sanding pad (Page 24).
- When sanding workpieces with irregular surfaces, such as cabinet doors, take very light sanding passes to prevent gouges. When the drum moves from sanding a wide surface to sanding a narrow surface, the load on the motor will be reduced, and the drum will speed up, causing a gouge.
- DO NOT edge sand boards. This can cause boards to kickback, causing serious personal injury. Edge sanding boards also can cause damage to the conveyor belt and sandpaper.
- When sanding workpieces with a bow or crown, place the high point up (prevents the workpiece from rocking) and take very light passes.
- Feed the workpiece at an angle to maximize stock removal and sandpaper effectiveness, but feed the workpiece straight to reduce sandpaper grit scratches for the finish passes.

Stock Inspection and Requirements

Some workpieces are not safe or may require modification before they are safe to sand. **Before sanding, inspect all workpieces for the following:**

- **Material Type:** This machine is intended for ONLY sanding natural and man-made wood products. This machine is NOT designed to sand metal, glass, stone, tile, drywall or cementitious backerboard.
- **Foreign Objects:** Nails, staples, dirt, rocks and other foreign objects are often embedded in wood. While sanding, these objects can become dislodged and tear the sandpaper. Always visually inspect your workpiece for these items. If they can't be removed, DO NOT sand the workpiece.
- **Excessive glue or finish:** Sanding workpieces with excess glue or finish will load up the abrasive, reducing its usefulness and lifespan.
- **Workpiece Dimensions:** DO NOT sand boards less than 8" long, 2" wide and $\frac{1}{8}$ " thick to prevent damage to the workpiece to reduce the risk of your hands contacting the sandpaper (see Figure 14).

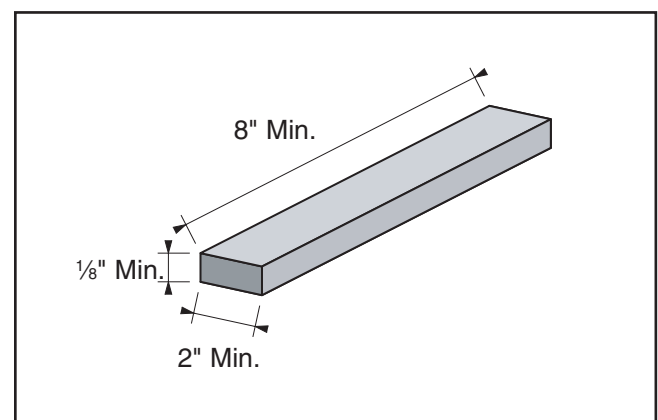

Figure 14. Minimum dimensions for sanding.



Depth of Cut

The optimum depth of cut will vary based on the type of wood, feed rate, and sandpaper grit. Under most sanding conditions, the depth should not exceed 0.006" (0.15 mm) (approx. ¼ turn of the handwheel). Each full turn of the crank handle raises the conveyor table approximately 0.027" (0.69 mm). Attempts to remove too much material can cause jamming, wood burning, rapid paper wear or tearing, poor finish, belt slippage, and motor damage.

To set the depth of cut:

1. Rotate the crank handle (**Figure 15**) until the conveyor table is well below the sanding drum, place the workpiece on the table, then raise the table, until the front pressure roller just touches the top of the workpiece.

Note: *When adjusting the table to sand a thicker workpiece, lower and then raise the table to remove backlash from the adjustment mechanism. If the table is lowered too far, the conveyor belt may rub against the chain, leaving grease on the belt.*

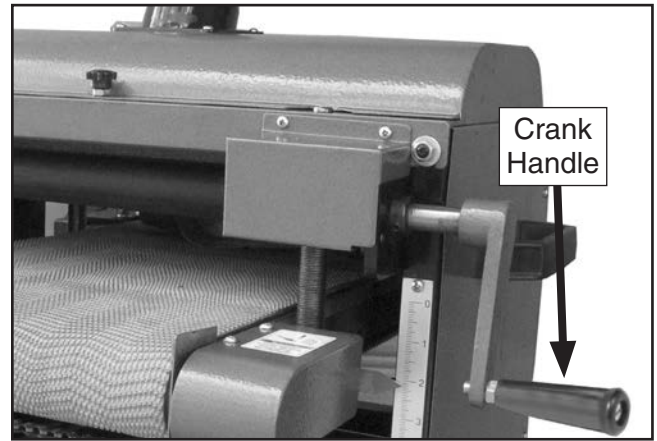

Figure 15. Setting depth of cut.

2. Turn the sander **ON**, start the conveyor (see **Variable Speed** on **Page 22**), and feed the workpiece into the sander. **SLOWLY** raise the conveyor table until the workpiece makes light contact with the sanding drum. This is the correct height to begin sanding the workpiece.



Variable Speed

The variable speed knob allows you to increase the feed rate from 2.47–17.3 FPM. The correct speed to use depends on the type of stock you are using (hardwood vs. softwood) and the stage of finish you are at with that workpiece.

As a general rule, a slower feed rate sands the surface smoother, but runs the risk of burning the wood; a faster feed rate removes material faster, but runs the risk of overloading the motor.

Use trial-and-error to determine the best settings for your specific applications.

To adjust the conveyor speed:

1. Start the conveyor.
2. Rotate the variable speed knob (**Figure 16**) clockwise to increase the feed speed, or counterclockwise to decrease the feed speed.



Figure 16. Variable speed knob.

Sanding

⚠️ WARNING

DO NOT sand more than one board at a time. Minor variations in thickness can cause one board to be propelled by the rapidly spinning sanding drum and ejected from the machine. NEVER stand directly in front of the outfeed area of the machine. Failure to do so could result in severe personal injury.

To sand a workpiece:

1. Adjust the table height according to the instructions in **Depth of Cut** on **Page 21**.
2. Start the dust collector, turn the sander **ON**, and start the conveyor.
3. Feed the workpiece through the sander. Retrieve the workpiece by standing at the side—not at the outfeed end.
4. Run wide stock through two or three times without adjusting the table height. Turn the stock 180° between passes to ensure an even cut.



Choosing Sandpaper

There are many types of sanding belts to choose from. We recommend aluminum oxide for general workshop environments. Below is a chart that groups abrasives into different classes, and shows which grits fall into each class.

Grit	Class	Usage
36	Extra Coarse	Rough sawn boards, thickness sanding, and glue removal.
60	Coarse	Thickness sanding and glue removal.
80–100	Medium	Removing planer marks and initial finish sanding.
120–180	Fine	Finish sanding.

The general rule of thumb is to sand a workpiece with progressively higher grit numbers, with no one grit increase of more than 50. Avoid skipping grits; the larger the grit increase, the harder it will be to remove the scratches from the previous grit.

Ultimately, the type of wood you use and your stage of finish will determine the best grit types to install on your sander.

Paper Replacement

The Model G0459/G0459P is designed for 3" wide hook-and-loop sandpaper rolls.

To change sandpaper:

1. DISCONNECT POWER TO THE SANDER!
2. Open the top cover to expose the drum.
3. Unwind the old sandpaper and notice the direction that it was wrapped around the drum.

4. Use the old sandpaper as a pattern to cut out the new sandpaper, or use the pattern in **Figure 17**, to cut the sandpaper to the necessary shape.

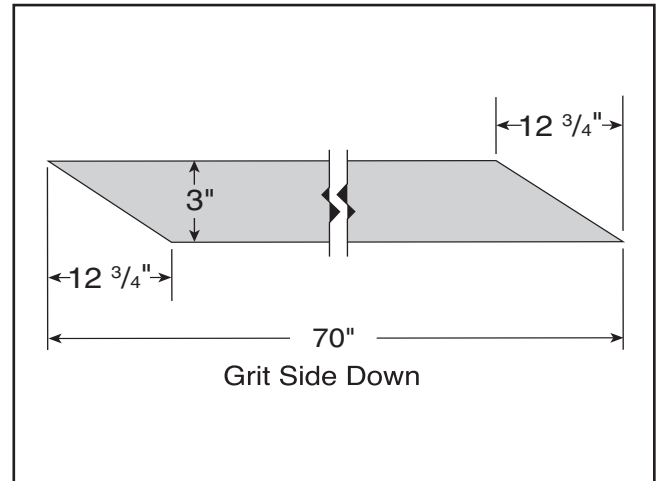

Figure 17. Sandpaper pattern.

5. Wrap the sanding drum with the new sandpaper. Make sure to wrap the sandpaper tight and try to keep the gaps to a minimum.
6. Tape both ends with 3/4" strapping tape (**Figure 18**), making at least two complete passes so that the second layer is directly on top of the first.

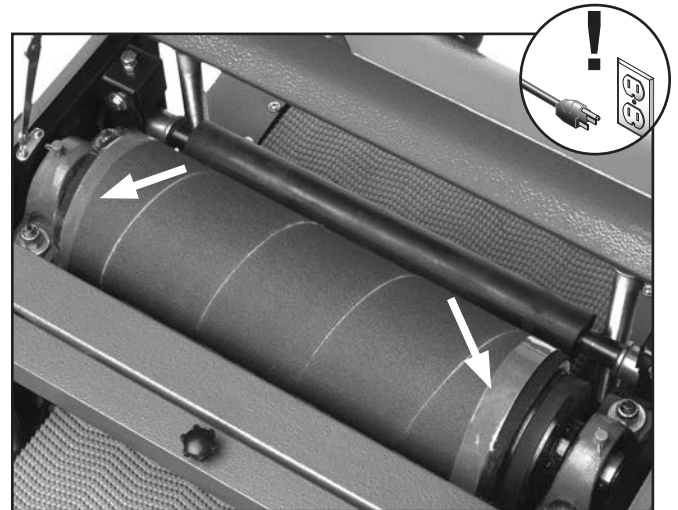

Figure 18. Sandpaper ends taped on Model G0459.



SECTION 5: ACCESSORIES

⚠️ WARNING

Some aftermarket accessories can be installed on this machine that could cause it to function improperly, increasing the risk of serious personal injury. To minimize this risk, only install accessories recommended for this machine by Grizzly.

NOTICE

Refer to the newest copy of the Grizzly Catalog for other accessories available for this machine.

Call 1-800-523-4777 To Order

Aluminum Oxide Hook & Loop Sanding Rolls, 3" x 50'

H4422—60 Grit: Use for thickness sanding and glue removal.

H4779—80 Grit: Use for removing planer marks and initial finish sanding.

H4423—100 Grit: Use for removing planer marks and initial finish sanding.

H4780—120 Grit: Use for finish sanding.

H4424—150 Grit: Use for finish sanding.

PRO-STICK® Sanding Pad

Extend the life of your sandpaper! Just feed this crepe-rubber cleaning pad through your drum sander to remove dust build-up from the sandpaper without damage.

<u>Size</u>	<u>Model</u>
12" X 15" X 3/4"	H7331

H1052—Clear Flexible Hose 4" x 10'

G3124—Wire Hose Clamps - 2 1/2"

G3123—Flexible Hose - 2 1/2" x 10'

Everything you need to hook your sander up to a dust collector.

G3119—4" x 2 1/2" Adapter

Made with Anti-Static Additive! Made in USA.

G4679—Anti-Static Grounding Kit

We've hand picked a selection of commonly used dust collection components for machines with 4" dust ports.

G1843—4" Plastic Blast Gate



Figure 19. Dust collection accessories.

G1163P—1 HP Light-Duty Dust Collector

Effective dust collection not only keeps your shop cleaner and more pleasant to work in, but it can also protect your health. 1HP motor, 450 CFM, 2 cubic feet bag capacity, 13 1/2" x 24" bag size, and 4" intake hole make this a great companion to your new sander!



Figure 20. Model G1163 Dust Collector.



SECTION 6: MAINTENANCE

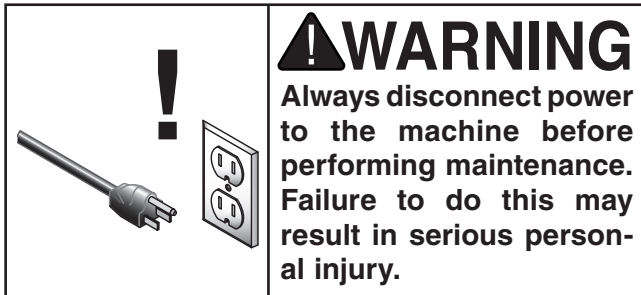

Schedule

For optimum performance from your machine, follow this maintenance schedule and refer to any specific instructions given in this section.

Daily Check:

- Loose mounting bolts.
- Worn switch.
- Worn or damaged cords or plugs.
- Damaged V-belt.
- Any other unsafe condition.

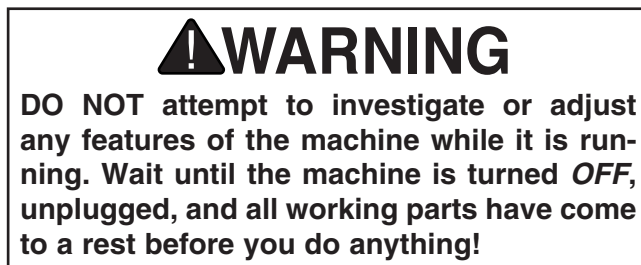

Cleaning

Cleaning the Model G0459/G0459P is relatively easy. From time to time, vacuum wood dust off of the internal components, especially the motor.

Lubrication

An essential part of lubrication is cleaning the components before lubricating them.

This step is critical because dust and chips build up on lubricated components, which makes them hard to move. Simply adding more grease to built-up grime will not result in smooth moving parts.

DISCONNECT POWER TO SANDER BEFORE PERFORMING LUBRICATION!

Chain

Clean the chain with mineral spirits and a brush or rag, then apply light machine oil to the chain. Turn the hand crank to move the conveyor up or down to distribute the oil. Do not apply too much oil, as it will attract dirt and sawdust and will clog the chain mechanism.

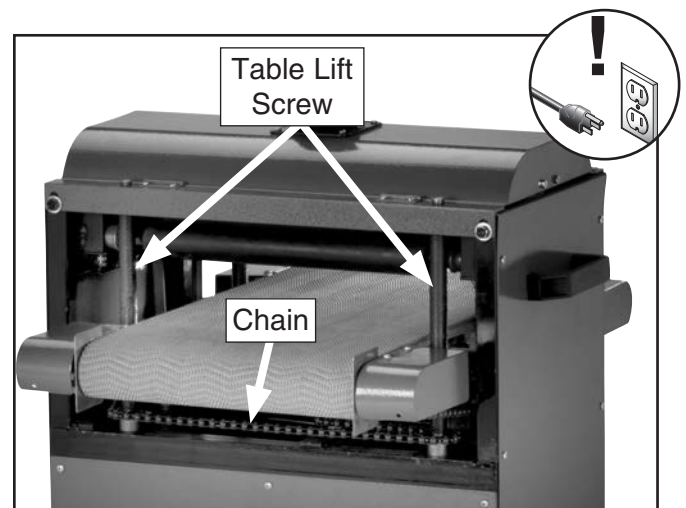

Figure 21. Chain and table lift screws lubrication locations.

Table Lift Screws

These should be lubricated with lithium grease every six months.

Use mineral spirits and a stiff brush to clean the table lift screws (**Figure 21**), then paint lithium grease onto the threads. Move the table up or down to spread the grease thoroughly over the threads.



Pillow Block Bearings

These must be lubricated every 20 hours of operation. Use a grease gun to pump one or two shots of a high-quality grease into each grease fitting (**Figure 22**), located on the top of each pillow block bearing.

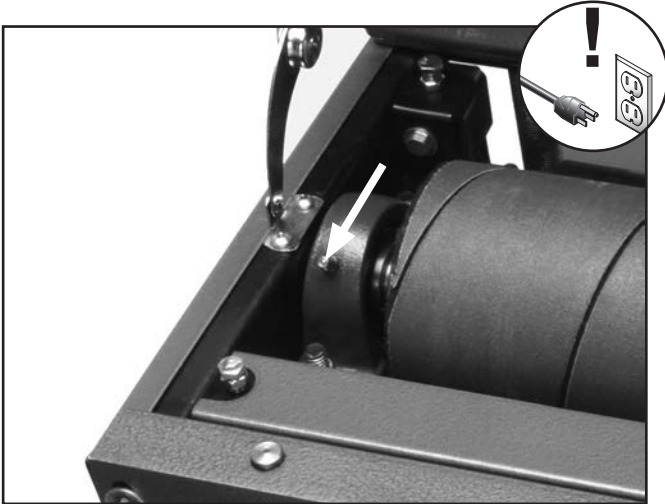

Figure 22. Location to lubricate pillow block bearing.

!WARNING

Failure to routinely inspect your drum sander for damage and wear could result in unsatisfactory work results, premature component or machinery failure, or operator injury. We recommend you create a checklist for routine inspection and maintenance. Remember to always disconnect the drum sander from its power source before attempting to inspect, adjust, or repair this machine!



SECTION 7: SERVICE

Review the troubleshooting and procedures in this section if a problem develops with your machine. If you need replacement parts or additional help with a procedure, call our Technical Support at (570) 546-9663.

Note: Please gather the serial number and manufacture date of your machine before calling.

Troubleshooting

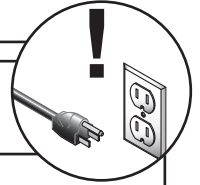

Motor & Electrical

Symptom	Possible Cause	Possible Solution
Machine does not start or a breaker trips.	<ol style="list-style-type: none"> 1. Plug or receptacle is at fault or wired incorrectly. 2. Start capacitor is faulty. 3. Motor connection is wired incorrectly. 4. Power supply is faulty, or is switched OFF. 5. Centrifugal Switch is at fault. 6. Motor ON button or ON/OFF switch is faulty. 7. Motor is at fault. 	<ol style="list-style-type: none"> 1. Test power plug and receptacle for good contact and correct wiring. 2. Test and replace capacitor as required (see photo, Page 44). 3. Correct motor wiring (see Page 45). 4. Make sure all hot lines and grounds are operational and have correct voltage on all legs. 5. Adjust or replace the centrifugal switch. 6. Replace faulty ON button or ON/OFF switch (see photo, Page 44). 7. Test, repair or replace motor.
Machine has vibration or noisy operation.	<ol style="list-style-type: none"> 1. Motor or component is loose. 2. Motor fan is rubbing on fan cover. 3. V-belt(s) is worn or is loose. 4. Pulley is loose. 5. Motor bearings are at fault. 6. Centrifugal switch. 	<ol style="list-style-type: none"> 1. Inspect, replace for stripped or damaged bolts/nuts, and re-tighten with thread locking fluid. 2. Replace dented fan cover, and replace loose or damaged fan. 3. Inspect belt(s), replace as matched sets, and re-tension. 4. Remove pulley, replace shaft, pulley, setscrew, and key as required, and realign. 5. Check bearings, replace motor or bearings as required. 6. Normal snap/click sound on RPM wind down. No problem exists.
Motor overheats.	<ol style="list-style-type: none"> 1. Motor overloaded. 2. Air circulation through the motor restricted. 	<ol style="list-style-type: none"> 1. Reduce load on motor. 2. Clean off motor to provide normal air circulation.



Sanding Operations

Symptom	Possible Cause	Possible Solution
Machine stalls or is underpowered.	<ol style="list-style-type: none"> Dust collection ducting is at fault. Low power supply voltage. Belt is slipping. Motor connection is wired incorrectly. Plug or receptacle is at fault. Pulley or sprocket is slipping on shaft. Motor bearings are at fault. Machine is undersized for the task. Motor has overheated. Centrifugal switch is at fault. Motor is at fault. 	<ol style="list-style-type: none"> Seal all leaks, size ducts correctly, eliminate bends, and refer to Dust Collection Basics Handbook (ISBN 0-9635821-2-7) for further recommendations. Make sure all hot lines and grounds are operational and have correct voltage on all legs. Replace bad belt, align pulleys, and re-tension. Correct motor wiring (see Page 45). Test power plug and receptacle for good contact and correct wiring. Replace loose pulley and shaft. Rotate motor shaft for noisy or burnt bearings, repair/replace as required. Use new sandpaper with appropriate grit, and reduce the feed rate/depth of sanding. Unobstructed motor cooling air flow, let motor cool, and reduce workload on machine. Adjust or replace the centrifugal switch. Test, repair or replace motor.
Machine lacks power; drum stops turning under load.	<ol style="list-style-type: none"> V-belt loose. Too much pressure on pressure rollers. 	<ol style="list-style-type: none"> Tighten V-belt (Page 30). Reduce pressure roller pressure (Page 35).
Machine slows when sanding, making a squealing noise, especially on start-up.	<ol style="list-style-type: none"> V-belt loose. V-belt worn out. 	<ol style="list-style-type: none"> Tighten V-belt (Page 30). Replace V-belt (Page 31).
Loud repetitious noise coming from machine.	<ol style="list-style-type: none"> Pulley setscrews or keys are missing or loose. Motor fan is hitting the cover. V-belt is defective. 	<ol style="list-style-type: none"> Inspect keys and setscrews. Replace or tighten if necessary. Adjust fan cover mounting position, tighten fan, or shim fan cover. Replace V-belt (Page 31).
Vibration when sanding.	<ol style="list-style-type: none"> Loose drum pillow block bearings. Worn drum pillow block bearings. 	<ol style="list-style-type: none"> Tighten drum pillow block bearings. Replace drum pillow block bearings.
Grinding, screeching, or rubbing noise when sanding drum is powered up.	<ol style="list-style-type: none"> Drum bearings lack sufficient grease. Drum bearings are worn and need replacement. 	<ol style="list-style-type: none"> Grease the pillow block bearings (Page 26). Replace the drum bearings.

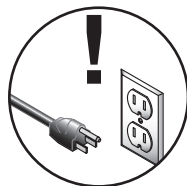

Symptom	Possible Cause	Possible Solution
Short V-belt lifespan.	<ol style="list-style-type: none"> 1. Pulleys not aligned correctly. 2. Improperly tensioned. 	<ol style="list-style-type: none"> 1. Align pulleys (Page 31). 2. Properly tension V-belts (Page 30).
Conveyor slips under load.	<ol style="list-style-type: none"> 1. Conveyor is too loose. 2. Too much load. 	<ol style="list-style-type: none"> 1. Tension conveyor (Page 32). 2. Decrease load.
Conveyor tracks to one side; conveyor hits the roller cover.	<ol style="list-style-type: none"> 1. Conveyor tracking is incorrect. 	<ol style="list-style-type: none"> 1. Track the conveyor so it runs straight (Page 32).
Workpiece pulls to one side during sanding operations.	<ol style="list-style-type: none"> 1. The sanding drum is not parallel with the table. 	<ol style="list-style-type: none"> 1. Adjust the sanding drum parallel to the table (Page 33).
Excessive snipe.	<ol style="list-style-type: none"> 1. Too much pressure from all the pressure rollers. 2. Too much pressure from the rear pressure roller. 3. Lack of outfeed support. 	<ol style="list-style-type: none"> 1. Reduce pressure roller pressure (Page 35). 2. Reduce rear pressure roller pressure (Page 35). 3. Set up outfeed table or have someone catch the workpiece as it comes out.
Workpiece kicks out of sander.	<ol style="list-style-type: none"> 1. Not enough pressure from the pressure rollers. 	<ol style="list-style-type: none"> 1. Increase pressure roller pressure (Page 35).
Sandpaper tears off drums during operation.	<ol style="list-style-type: none"> 1. Nail/staple in workpiece. 2. Sandpaper not tightened or fastened correctly. 3. Drum not perpendicular to the feed direction. 	<ol style="list-style-type: none"> 1. Sand only clean workpieces. 2. Install the sandpaper correctly (Page 23). 3. Adjust the drum perpendicular to the feed direction (Page 33).
Table elevation controls are stiff and hard to adjust.	<ol style="list-style-type: none"> 1. Table lift screws are dirty or loaded with sawdust. 	<ol style="list-style-type: none"> 1. Clean and regrease table lift screws (Page 25).
Poor dust collection.	<ol style="list-style-type: none"> 1. Dust collection lines incorrectly sized for this machine. 2. Dust collector underpowered or too far away from this machine. 	<ol style="list-style-type: none"> 1. Use at least an 8" main line with two 6" branch lines that each Y into 2½" at the machine. 2. Upgrade your dust collector or decrease the distance from the dust collector to the machine.
Grease on conveyor belt	<ol style="list-style-type: none"> 1. Chain too low. 	<ol style="list-style-type: none"> 1. Raise table far enough up so it doesn't touch chain.

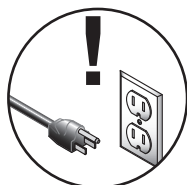

Gauge Blocks

Tools Needed:	Qty
6' Long 2x4.....	1
Miter Saw (or Circular Saw).....	1
Jointer.....	1
Table Saw.....	1

The gauge blocks described here will be required to complete most of the service procedures in this section.

To make the gauge blocks:

1. Edge joint the concave edge of the 2x4 flat on a jointer, as shown in **Figure 23**.

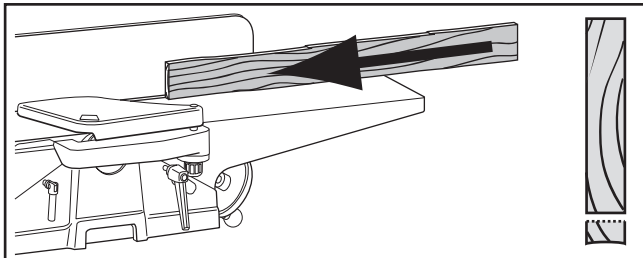

Figure 23. Edge jointing on a jointer.

2. Place the jointed edge of the 2x4 against the table saw fence and rip cut just enough off the opposite side to square up the two edges of the 2x4, as shown in **Figure 24**.

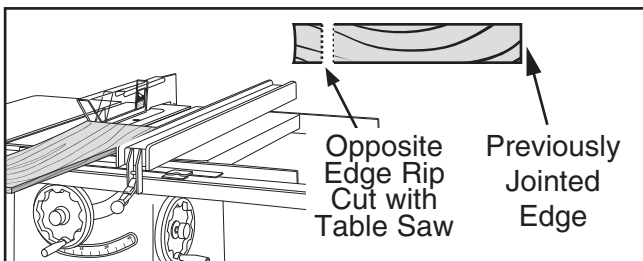

Figure 24. Rip cutting on a table saw.

3. Cut the 2x4 into two even pieces to make two 36" long wood gauge blocks.

Note: *Steps 1 & 2 can be skipped, but having these wood gauge blocks at an even height is critical to the accuracy of your overall adjustments.*

V-Belt Service

Tools Needed:	Qty
Hex Wrench 6mm.....	1
Wrench 12mm.....	1
Straightedge.....	1
Ruler.....	1
Phillips Head Screwdriver #2.....	1

Tension

A new V-belt often stretches and loosens up during the first 16 hours of use. After this period, it should be inspected and re-tensioned if necessary.

Proper tension is important for optimum power transmission. However, too much tension may cause premature bearing failure.

To test V-belt tension:

1. Remove the right handle and side panel.
2. Using a straightedge and ruler (**Figure 25**), push on the middle of the V-belt. The correct V-belt tension is achieved when the V-belt can be deflected $\frac{1}{2}$ "– $\frac{3}{4}$ " with moderate pressure.

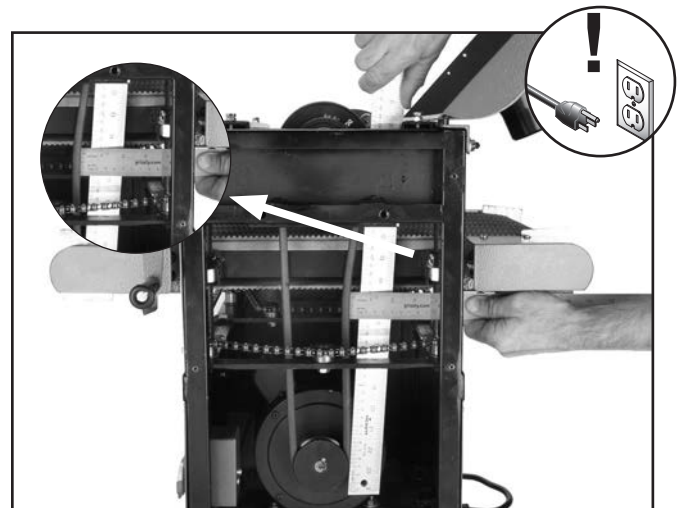

Figure 25. Checking V-belt tension with a straightedge and a ruler.

3. Re-install the side panel and handle.



To adjust V-belt tension:

1. DISCONNECT POWER TO THE SANDER!
2. Open the rear panel.
3. Loosen the motor mount bolts and raise or lower the motor bracket, as shown in **Figure 26**, to loosen or tighten the V-belt.
4. Tighten the motor mount bolts and replace the rear panel.

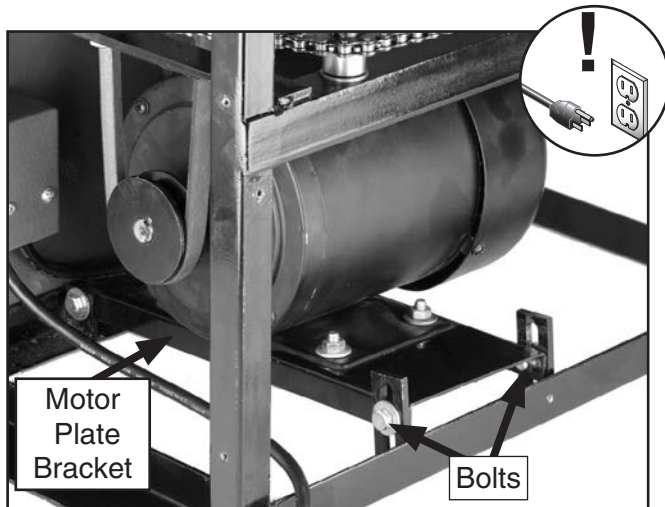

Figure 26. V-belt tension controls.

Removal/Replacement

Replace the V-belt if you notice fraying, cracking, glazing, or any other damage. A worn/damaged V-belt will not provide optimum power transmission from the motor to the drums.

V-belt removal and replacement is simply a matter of loosening the V-belt, rolling it off of the pulleys, replacing it, and re-tensioning it.

Pulley Alignment

Pulley alignment is another important factor in power transmission and belt life. The pulleys should be parallel to each other and in the same plane (coplanar) for optimum performance.

Each pulley can be adjusted by loosening the set screws that secure the pulley to the shaft, sliding the pulley in/out, and retightening the set screws to lock the pulley in place.

To align the pulleys:

1. DISCONNECT POWER TO THE SANDER!
2. Remove the right handle and side panel.
3. Remove the V-belt.
4. Place a straightedge across the face of the motor pulley and drum pulley to check the alignment. The straightedge should sit evenly on the top and bottom part of both pulleys, as shown in **Figure 27**.

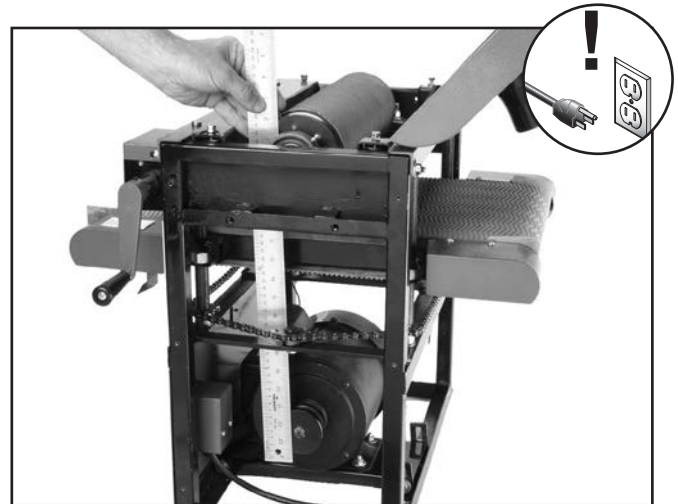

Figure 27. Checking pulley alignment with a straightedge.

5. Adjust the pulleys as necessary until they are all coplanar with each other.
6. Re-install the side panel and handle.



Conveyor Tensioning & Tracking

Tools Needed:	Qty
Wrench 19mm	1
Phillips Head Screwdriver #2	1

Tensioning

The conveyor may slightly stretch with continued use and will eventually need to be tensioned. This is most obvious if the conveyor starts slipping on the rollers.

When you tension the conveyor, focus on tensioning the adjustment bolts in even increments. Tensioning one side more than the other will cause tracking problems, which will require you to take additional steps to get the sander operating correctly.

To tension the conveyor:

1. Use a magic marker, correction fluid, or fingernail polish to mark the front of the conveyor tensioning bolt on both sides (**Figure 28**). This step will aid you in keeping track of the rotations as you turn the bolts, so they remain as even as possible.

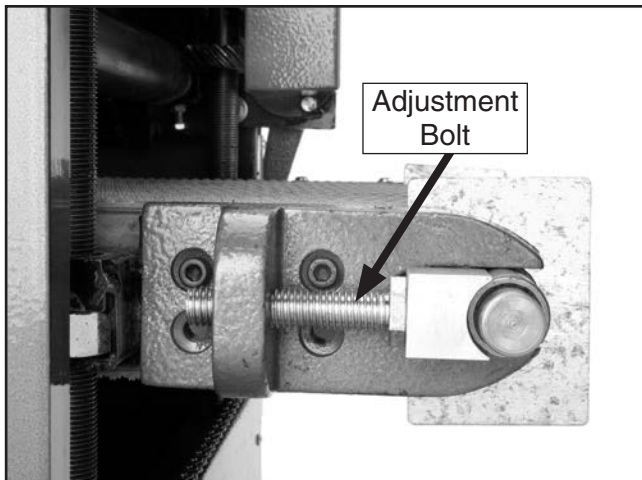

Figure 28. One side of conveyor tensioning & tracking controls (guard removed for clarity).

Note: Removing the front right and left roller guard covers makes it easier to access the adjustment bolts. Be sure to re-install the guards when adjustments are complete.

2. Turn both of the conveyor adjustment bolts counterclockwise one full turn at a time until the conveyor belt no longer slips during operation.

—If the conveyor starts tracking to one side, immediately turn the drum sander **OFF** and perform the tracking instructions.

Tracking

The conveyor must track straight. If the conveyor tracks to either side, then the tracking must be corrected or the conveyor will become damaged and have to be replaced.

Replacing a damaged conveyor is a big job. Always be careful to make sure that the belt does not travel too far to one side or the other.

Tracking the conveyor is a balancing process that takes patience and a small degree of trial-and-error. Usually you must over-tighten the loose side (the side the belt is tracking towards) to make the conveyor move to the middle of the rollers, then loosen that same side to make the conveyor stay in position. If you adjust the bolt too much either way, then you have to repeat the process until the conveyor rides in the middle and stays there during continuous operation.

To track the conveyor:

1. Turn the conveyor **ON** and watch it track.
2. Determine which side the conveyor is tracking towards (the loose side) and tension the adjustment bolt on that side until the conveyor tracks in the opposite direction.

Note: Tracking changes may take up to three minutes before they are noticeable.

3. When the conveyor is near the middle of the rollers or table, loosen the adjustment bolt until the conveyor stops moving and tracks straight.

—If the conveyor tracks too far to the other side, then adjust the bolt as necessary to bring it back and repeat **Steps 2 & 3** until the tracking is correct.



Drum Adjustments

Tools Needed:	Qty
Hex Wrench 4mm.....	1
Wrench 19mm.....	1
Wrench 10mm.....	1
Socket 14mm.....	1
Measuring Tape.....	1
Gauge Blocks (see Page 30).....	2
Feeler Gauge Set.....	1

For the Model G0459/G0459P Drum Sander to function properly, the sanding drum must be aligned in two directions: (1) parallel to the conveyor belt (see **Figure 29** below) and (2) perpendicular to feed direction (see **Figure 30**).

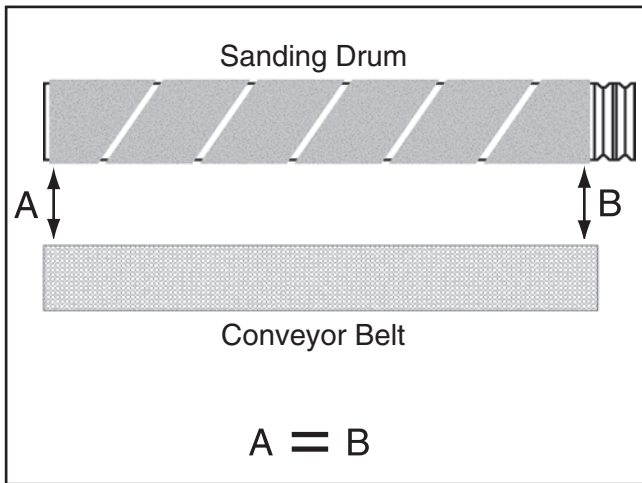

Figure 29. Drum parallel to conveyor belt.

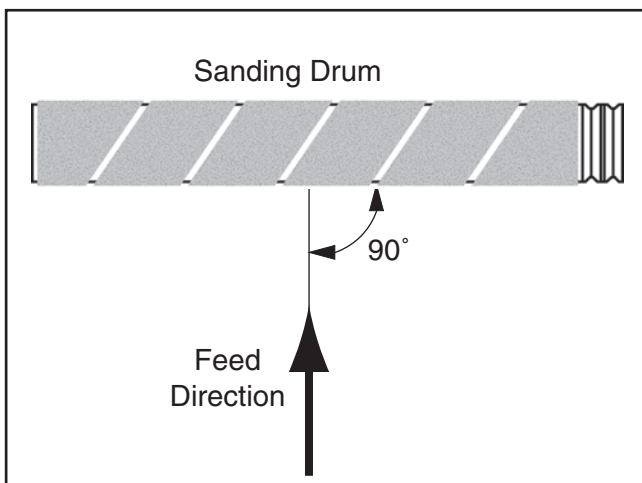

Figure 30. Drum perpendicular to feed direction.

The drums can be adjusted in fine increments at the pillow block bearings and in larger increments by using the table lift screws (**Page 37**).

While adjusting the drum, keep in mind that having the drum parallel to the conveyor belt is critical to the sanding operation. Care should be taken to make the tolerances as close as possible (within 0.002" from one side to the other) when adjusting the drum height.

The tolerances for having the drum perpendicular to the feed direction are much more forgiving, even allowing up to 1/8" difference from one side to the other before causing problems.

To align the sanding drum parallel to the conveyor belt:

1. DISCONNECT POWER TO THE SANDER!
2. Open the top cover.
3. Loosen the lock nuts (see **Figure 31**) on the drum pillow block bearing.

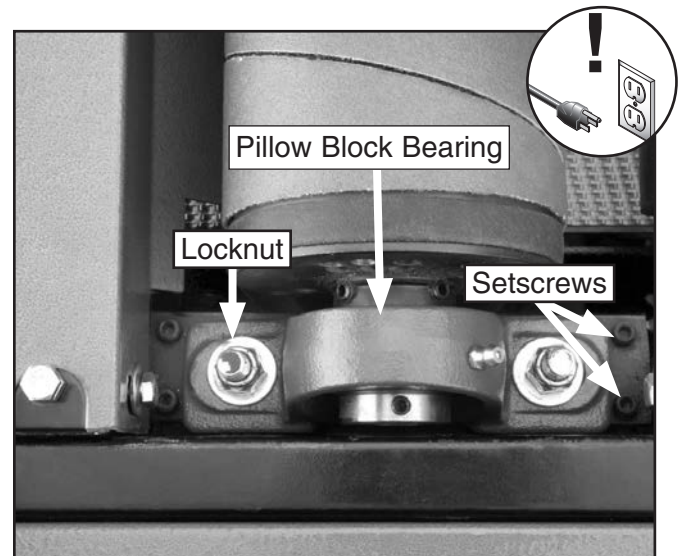

Figure 31. Pillow block bearing adjustments.



- Place the gauge blocks on the conveyor table and position them under the pressure rollers, as shown in **Figure 32**.



Figure 32. Gauge blocks positioned under pressure rollers and sanding drum.

- Raise the table until the gauge blocks just touch the bottom of the sanding drum.

Note: A good way to know when they are touching is to rock the sanding drum back and forth while raising the table until you hear or feel contact with the gauge blocks.

- Lower the table one full turn of the crank handle. Wait until the chain starts moving before starting to count the crank handle rotation.
- Starting at one end, place a 0.002" feeler gauge between the sanding drum and the gauge block. (The feeler gauge should slide with moderate resistance, without forcing the drum to roll.)
- Repeat **Step 7** at the other end of the drum.

—If the difference between the two sides is 0.002" or less, skip to the subsection that covers how to adjust the sanding drum perpendicular to the feed direction on this page.

—If the difference between the two sides is more than 0.002", then one side must be adjusted to within 0.002" of the other (with the ultimate goal of making them dead even). Continue to the next step.

To adjust the pillow block bearings:

- Loosen the lock nuts (see **Figure 31**) on one of the pillow block bearings that requires adjustment.

- Rotate the setscrews $\frac{1}{8}$ of a turn clockwise to raise the pillow block bearings (see **Figure 31**).

Note: Turn all setscrew sets an equal amount.

- Tighten the lock nuts and recheck the alignment using the gauge blocks, repeating **Steps 1–8** from the previous subsection. Tightening the lock nuts will pull the drum downward slightly. Be sure to adjust to compensate for this movement. **Do not over tighten the lock nuts. The pillow block bearings can break if over tightened.**

To adjust the sanding drum perpendicular to the feed direction:

- DISCONNECT POWER TO THE SANDER!
- First measure the distance between the outside of the drum and the inside of the dust scoop (**Figure 33**). The distances should be within $\frac{1}{8}$ " of each other at each end of the drum.

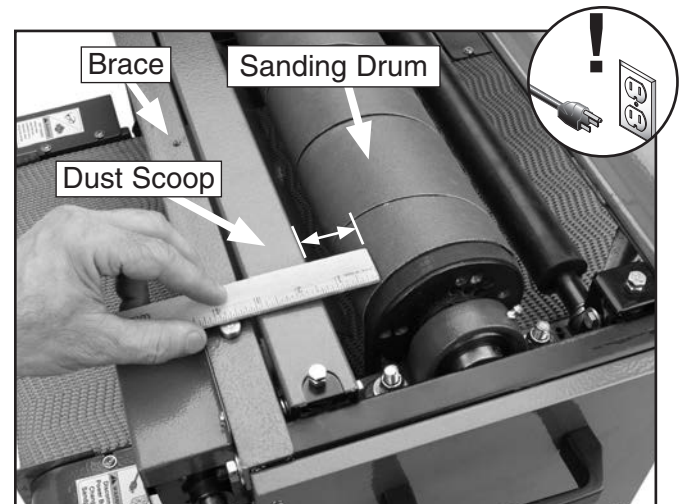

Figure 33. Measuring distance between drum and dust scoop.

- If the measurements are not within $\frac{1}{8}$ ", the drum can be moved by loosening the lock nuts on the pillow block bearings and moving one end of the drum forward or backward as necessary in the slotted holes.

Note: After you have adjusted the drum, do not forget to tighten the lock nuts and recheck the alignment by repeating **Steps 1–3**.



Pressure Roller Height

Tools Needed:	Qty
Wrenches/Sockets 10mm.....	1
Gauge Blocks (see Page 30)	2

Factory Setting:

Distance Below Sanding Drum0.080" (2mm)

The pressure rollers are factory set at 0.080" (2mm) below the bottom of the sanding drum and are fully adjustable either up/down with the four lower adjustment bolts (**Figure 34**). After the adjustment has been made, always lock the jam nuts against the bottom to prevent them from moving.

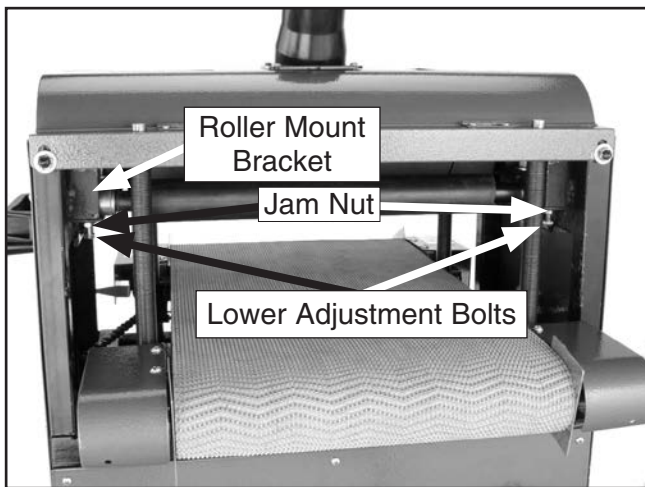

Figure 34. Pressure roller adjustment hex nuts.

Proper pressure on the workpiece helps avoid kickback and keeps the workpiece from slipping. However, as pressure increases on the workpiece, snipe also increases (some degree of snipe is normal with all drum sanders).

If snipe becomes a problem, you can minimize it by reducing pressure. To lower pressure, turn the lower adjustment bolts counterclockwise to raise the pressure roller height. To increase pressure, turn the lower adjustment bolts clockwise (lowering pressure rollers).

However, you can only minimize snipe so much before the workpiece will slip or kick out, causing a hazard to the operator. If this happens, you have raised the pressure rollers too high for them to function as intended—the pressure rollers **MUST** be lowered to prevent injury.

!WARNING

Raising the pressure rollers too high to minimize snipe will cause the workpiece to slip or kick out, causing a hazard to the operator. You **MUST lower the pressure rollers to prevent injury!**

These instructions will restore the pressure rollers to the factory setting.

To adjust the pressure rollers to the factory setting:

1. DISCONNECT POWER TO THE SANDER!
2. Open the top cover.
3. Place the gauge blocks on the conveyor table and position them under all the pressure rollers (**Figure 32**).
4. Raise the table so the gauge blocks touch the bottom of the sanding drum, as shown in **Figure 35**.

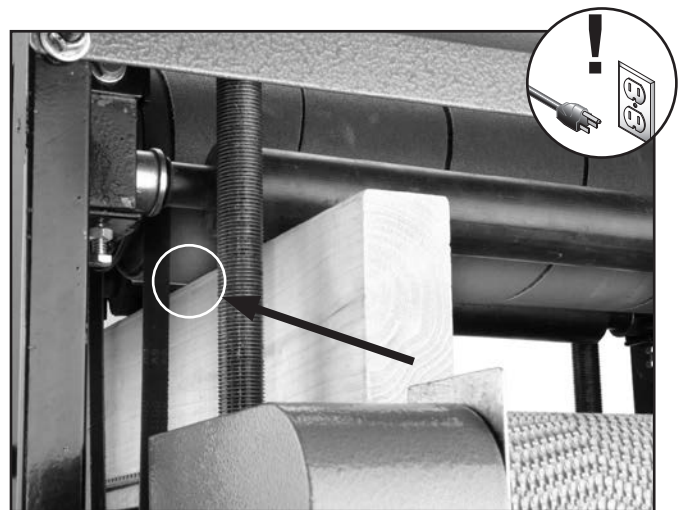

Figure 35. Gauge block touching bottom of sanding drum.



- Turn the crank handle three full rotations (counting from the point of actual table movement so handwheel freeplay does not affect your count) to lower the table so the gauge blocks are below the pressure rollers, as shown in **Figure 36**.

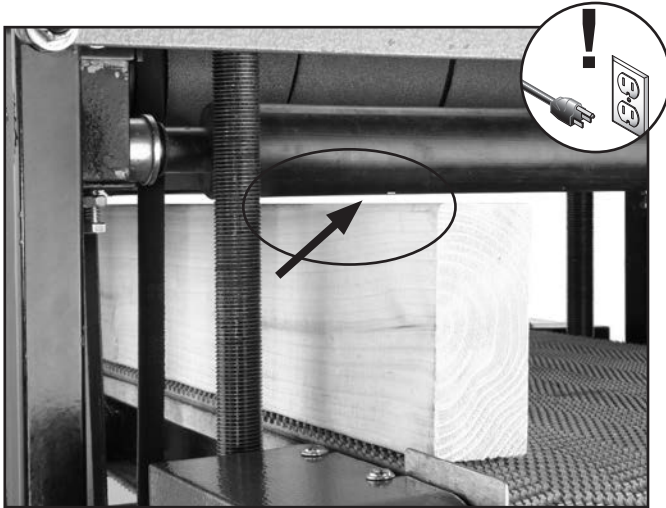

Figure 36. Gauge blocks below pressure rollers.

Note: You may open the side covers to gain better access for the following adjustments. This is not required.

- Turn a lower adjustment bolt on one side of a pressure roller clockwise to lower that end of the pressure roller until it touches the gauge block.
- Repeat **Step 6** for the opposite side of the same pressure roller.
- Repeat **Steps 6–7** with the second pressure roller. Each pressure roller should look like **Figure 37** when properly adjusted.

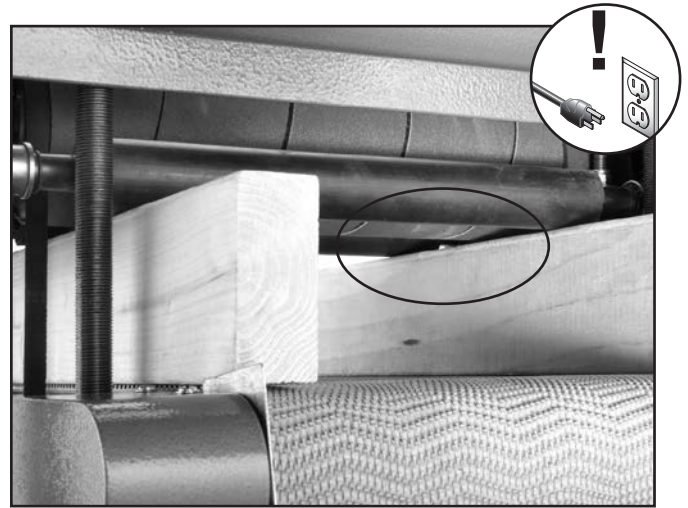

Figure 37. Pressure rollers set correct distance below bottom of sanding drum.

- Tighten the jam nuts (**Figure 34**) to lock the adjustment.

Scale Pointer Calibration

Tools Needed:	Qty
Phillips Head Screwdriver.....	1

In order for the scale pointer to be accurate, it must be calibrated.

We recommend calibrating your scale pointer any time you adjust the drum height or table lift screws.

To calibrate the scale pointer:

- Sand a workpiece with the drum sander and measure the thickness of the sanded workpiece.
- Loosen the screw that secures the scale pointer and adjust it to the thickness of the workpiece.



Table Lift Screws

Tools Needed:	Qty
Hex Wrench 6mm.....	1
Wrench/Socket 12mm	1
Chalk, Correction Fluid, or Paint	1
Phillips Head Screwdriver #2	1
Flat Head Screwdriver.....	1

The table lift screws are connected by a chain and driven by the crank handle. (When the chain is removed from a sprocket on one of the lift screws, that lift screw can adjust that portion of the table up/down independently to assist in setting the table parallel to the drum.)

Adjusting the table lift screws will only be necessary if you need to adjust the drum height more than allowed at the pillow block bearing adjustments, or if you have removed the table or chain (see **Page 41**) during a service procedure and you need to reset the drum parallel to the table.

Each complete tooth rotation on the sprocket represents 0.007" or .18mm of table elevation movement. For example, if the rear of the table was 0.007" low, rotate both rear table lift screws to the next sprocket tooth in the same chain position. You can easily rotate the sprockets from the top of the table lift screws with a flat head screwdriver.

To adjust the table lift screws:

1. DISCONNECT POWER TO THE SANDER!
2. Open the right side and front panels.
3. Raise the table up to at least the 1" mark on the height scale.
4. At the lift screw that needs to be adjusted, mark the end of a sprocket tooth and the chain hole where that tooth is meshed, as shown in **Figure 38**.

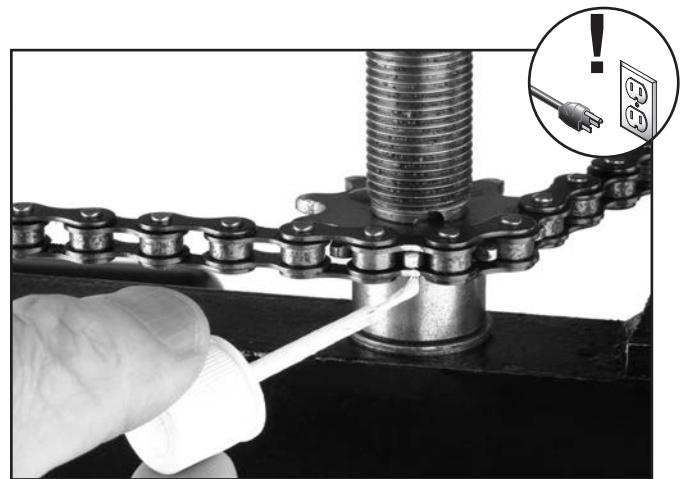

Figure 38. Marking sprocket tooth and chain.

5. Loosen the chain by loosening the hex nut on the bottom of the idler roller sprocket shown in **Figure 39**.

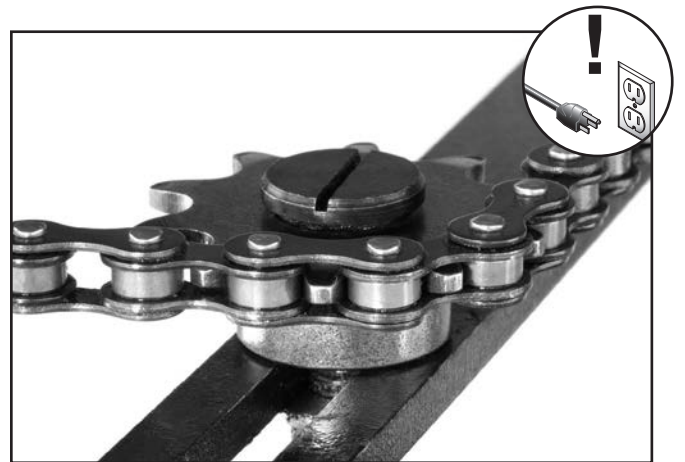

Figure 39. Idler roller sprocket.

6. Carefully move the chain off of only the marked sprocket.
7. Keep track of the marked chain hole and rotate the sprocket the necessary number of teeth away from the marked one to meet the difference in height needed.
8. Fit the chain back over the sprocket, making sure the new sprocket tooth is inserted into the marked chain hole.
9. Re-tension the chain and check the new height setting.
10. Repeat **Steps 5–9** as needed until the table height is parallel to the drums in all four corners, tighten the idler sprocket and calibrate the scale pointer.

NOTICE

Marking chain and sprocket locations will save you a substantial amount of time when you re-install the chain. Make sure you have done this before removing the chain.



Conveyor Belt Replacement

Tools Needed:	Qty
Hex Wrench 6mm.....	1
Wrench/Socket 19mm	1
Wrenches/Socket 14mm.....	2
Wrench/Socket 12mm	1
Wrench 10mm	1
Phillips Head Screwdriver #2	1
Measuring Tape.....	1
Gauge Blocks (see Page 30)	2
Feeler Gauge Set.....	1
Assistant for Lifting Help	1
Flashlight or Work Light.....	1
Correction Fluid or Paint.....	1
Black Felt Tipped Pen	1

Replacing the conveyor belt is a big job and requires moderate mechanical skill and a fair amount of patience. For planning purposes, expect to have your machine out of operation for at least a few hours.

As you remove hardware to complete these instructions, we recommend putting all the bolts, screws, washers, etc. back into the holes from which they came. This simple habit will take slightly longer when disassembling the machine, but it will save you a lot of time and reduce frustration during reassembly.

To replace the conveyor belt:

1. DISCONNECT POWER TO THE SANDER!
2. Remove the top cover by loosening the hex bolts and removing the Phillips head screws (**Figure 40**) securing the top cover support.

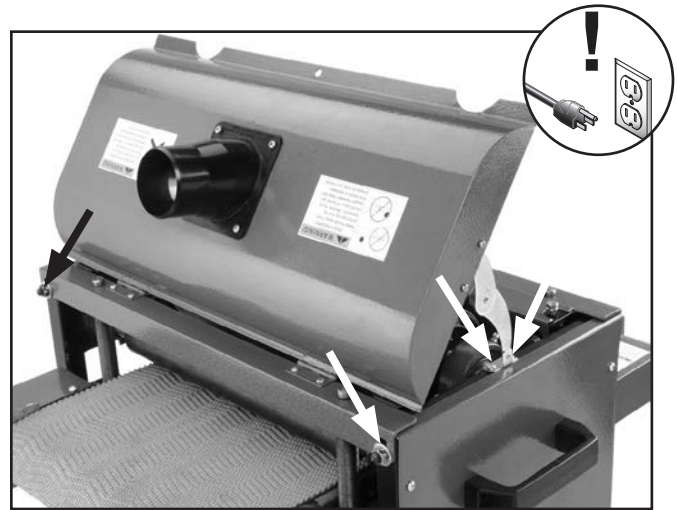

Figure 40. Locations to remove top cover mounting hardware.

3. Remove the right handle and side panel (2 cap screws and 6 tap screws).
4. Remove the gear cover (2 Phillips head screws) and loosen the 2 hex nuts securing the brace and remove it.
5. Remove the dust scoop (4 hex bolts and 4 flat washers), compression springs and spring plates (**Figure 41**) from the front pressure roller and set the roller aside.

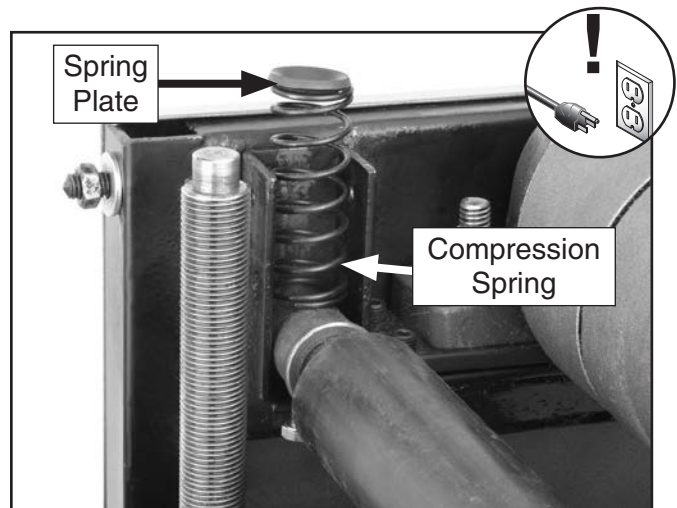

Figure 41. Front pressure roller components.



- Remove the rear pressure roller (4 hex bolts and 4 flat washers) along with the brackets, compression springs, and spring plates shown in **Figure 42**.

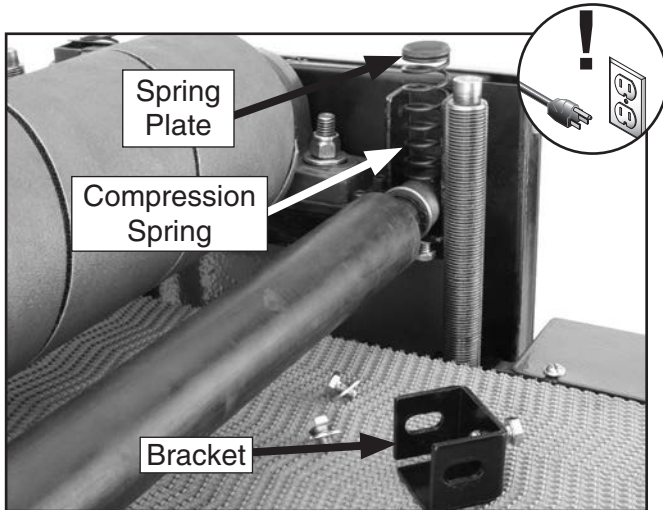

Figure 42. Rear pressure roller components.

- Remove the rear panel.
- Loosen the hex bolts securing the motor bracket to the frame, raise the motor and remove the V-belt from the motor pulley (see **Page 31** for help). The drum sander should now look similar to **Figure 43**.

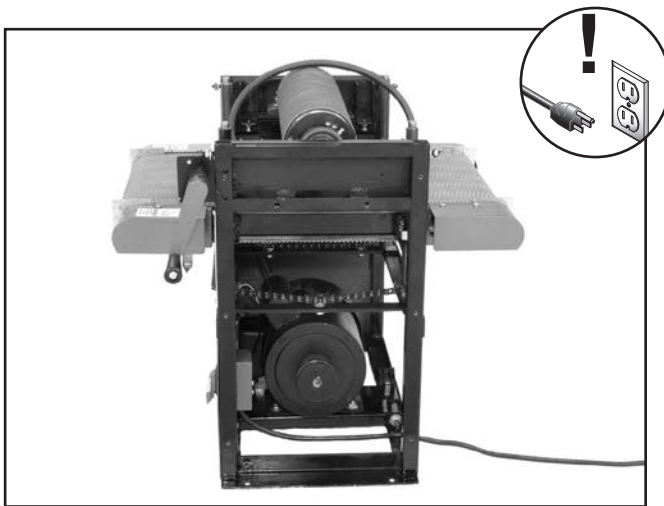

Figure 43. Drum sander disassembled to **Step 8**.

- Remove the sanding drum (4 lock nuts and 4 flat washers) and V-belt (**Figure 44**).

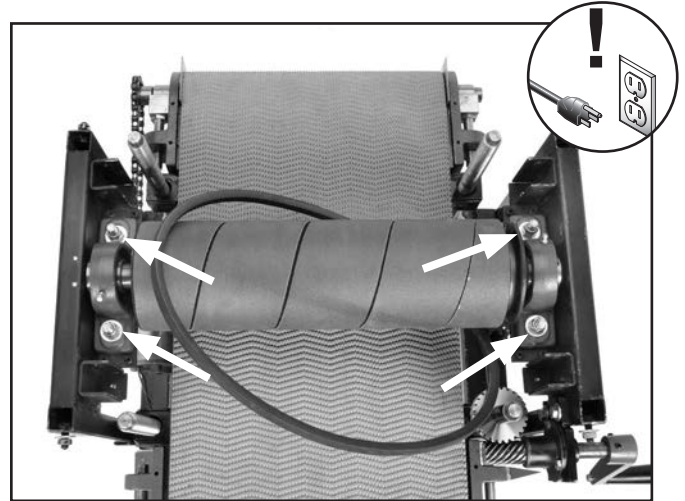

Figure 44. Location to remove sanding drum components.

- Remove the front roller end guard covers (4 Phillip head screws) and the rear roller end guard covers (4 Phillip head screws), and set the covers aside. The drum sander should now look similar to **Figure 45**.

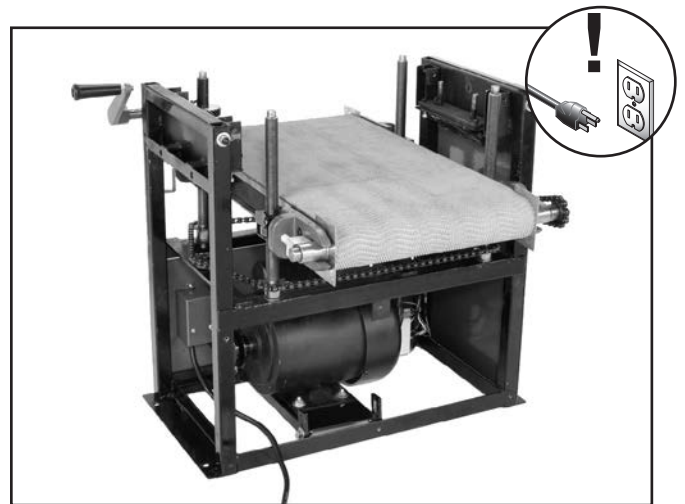

Figure 45. Drum sander disassembled to **Step 10**.



11. Mark the top of the table lift screws with arrows (all pointing in same direction) and mark the screws with liquid correction fluid above the mounting bracket (**Figure 46**). Later, when you reassemble the conveyor table, you can use these marks to reset the table height close to the current position.

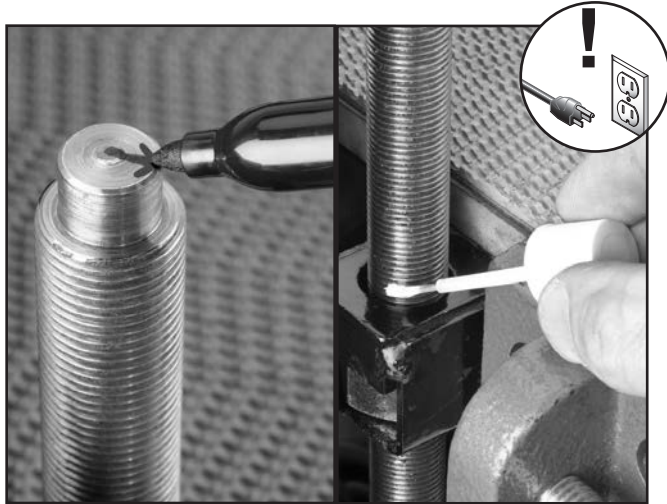

Figure 46. Locations to mark table lift screws.

12. Mark the chain and sprockets with correction fluid.
13. Loosen the idler roller sprocket (**Figure 39**), carefully pull the chain off of all the sprockets, and remove it from the cabinet.
14. Loosen the conveyor belt at the front adjustments, as shown in **Figure 47**.

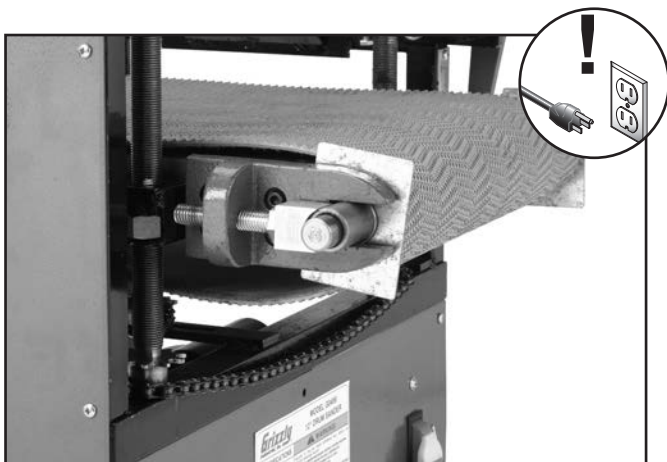

Figure 47. Conveyor belt loosened at the front adjustments (only one shown).

15. Disconnect the conveyor feed motor wires from the circuit board.
16. Remove the scale pointer.

*Before removing the table, note the number and location of brass shims (**Figure 48**) under the table lift screws. Knowing their correct position will help you align the conveyor table during reassembly.*

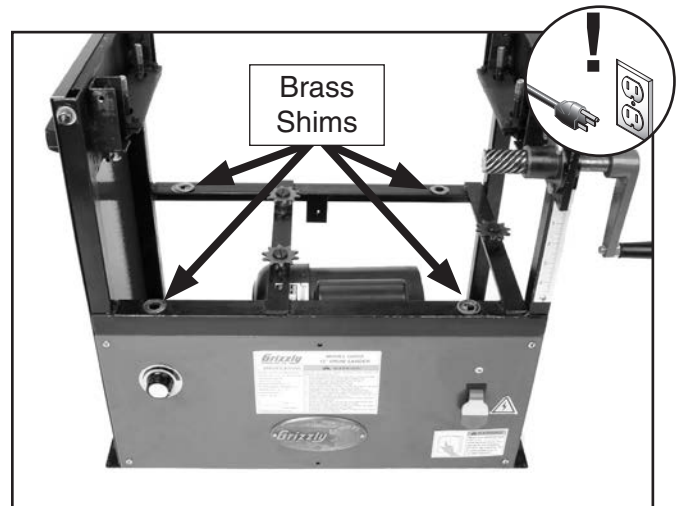

Figure 48. Brass shims.

17. With the help of an assistant, carefully lift the table off of the drum sander cabinet, as shown in **Figure 49**.

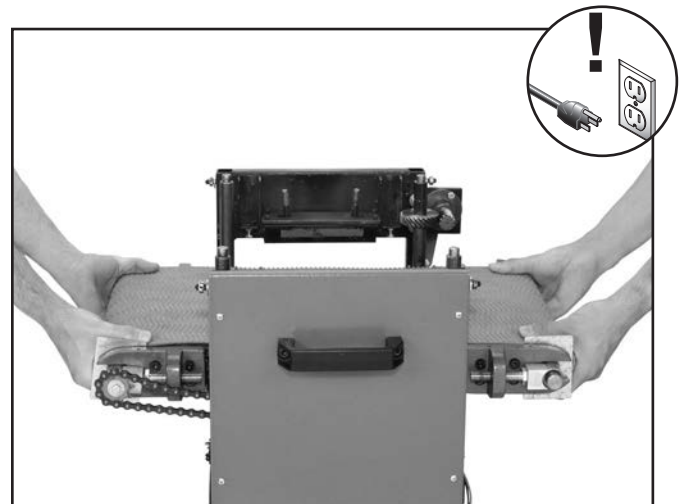

Figure 49. Example of lifting the table off of the drum sander cabinet with two people.



18. Lay the conveyor table on the edge of a workbench so the conveyor motor can hang freely.
19. Remove the conveyor motor (4 cap screws) from the conveyor motor cover, and remove the conveyor motor cover from left rear roller bracket (3 cap screws and 3 flat washers).

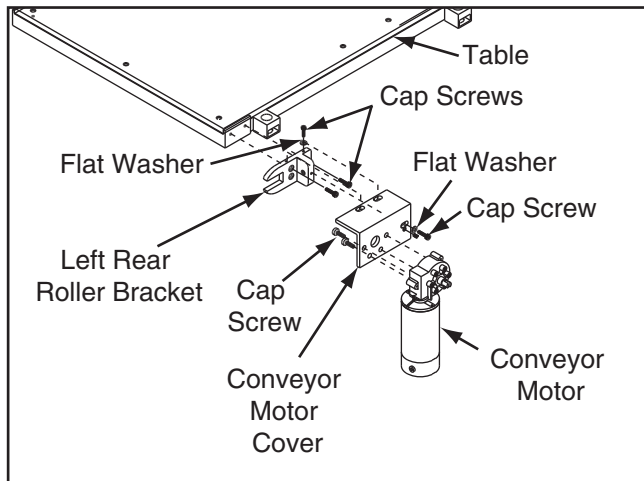

Figure 50. Removing conveyor motor and rear roller bracket (not all components shown for clarity).

20. Remove the rear left roller bracket (2 cap screws).
21. Remove the rear roller.
22. Remove the front left roller bracket (2 cap screws) and the front roller.
23. Remove the front right and rear roller brackets (4 cap screws).
24. Place the right side of the conveyor on a flat surface, then unthread and remove the front and rear table lift screws.
25. Remove the belt. The table should look like **Figure 51**.

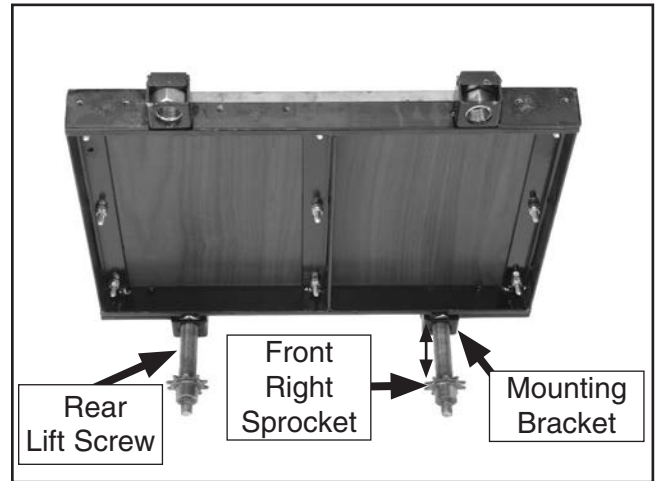

Figure 51. Conveyor belt removed from table.

26. Measure the distance between the front right table lift screw sprocket and the mounting bracket. If necessary, rotate the rear shaft so the sprocket-bracket distance is the same as the front right table lift screw.
27. Install the new belt.
28. Re-install the front left and rear left table lift screws to match the front right lift screw height.
29. Reassemble the drum sander by reversing the disassembly steps.
30. After reassembly, adjust the drums and pressure rollers to their proper settings. See **Drum Adjustments** on **Page 33** and **Pressure Roller Height** on **Page 35**.
31. After you have re-installed the conveyor table, make sure the four lower pressure roller adjustment bolts are threaded the same distance into the roller mount brackets (**Figure 34**).
32. After re-installing the top cover and brace, tighten the mounting bolts.



33. Before re-installing the gear box cover, try raising and lowering the conveyor table with the crank handle. If the helical gears (see **Figure 52**) are not engaged, the crank handle will only raise the table.

If this happens, loosen the crank handle mounting bolts, and move the helical gear around until the teeth mesh with the helical crank handle gear, then secure the crank handle.

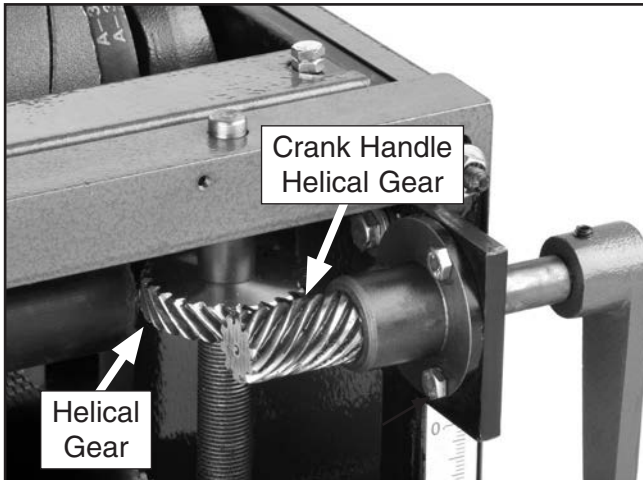

Figure 52. Helical gear and crank handle helical gear.

34. Re-install and secure the brace.
35. Try moving the conveyor table up and down.
36. Continue adjusting the helical gear and crank handle helical gear until the crank handle raises and lowers the conveyor table.

Changing Motor Brushes

Tools Needed:	Qty
Flat Head Screwdriver	1

If the motor fails to develop full power or otherwise appears to run sluggishly, the motor brushes may need to be replaced.

To replace the motor brushes:

1. DISCONNECT POWER TO THE SANDER!
2. Remove each brush cover and remove the brushes from the motor, as shown in **Figure 53**.

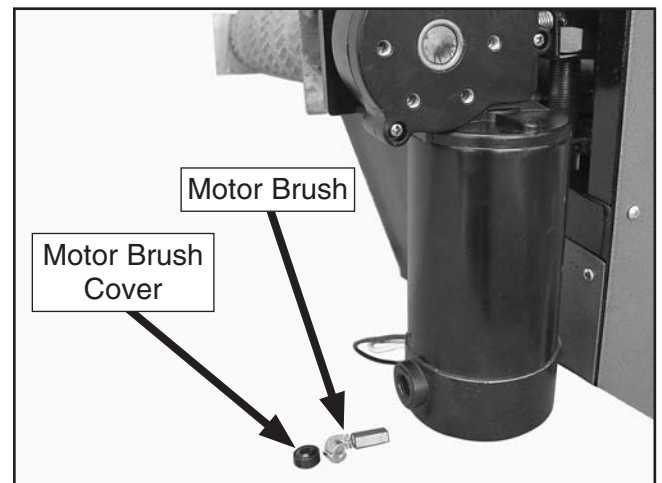

Figure 53. Motor brush components removed (one of two brushes shown).

3. Insert the new carbon brushes into the holes in the motor housing.
4. Re-install the brush covers.



SECTION 8: WIRING

These pages are current at the time of printing. However, in the spirit of improvement, we may make changes to the electrical systems of future machines. Compare the manufacture date of your machine to the one stated in this manual, and study this section carefully.

If there are differences between your machine and what is shown in this section, call Technical Support at (570) 546-9663 for assistance BEFORE making any changes to the wiring on your machine. An updated wiring diagram may be available. **Note:** *Please gather the serial number and manufacture date of your machine before calling. This information can be found on the main machine label.*

WARNING

Wiring Safety Instructions

SHOCK HAZARD. Working on wiring that is connected to a power source is extremely dangerous. Touching electrified parts will result in personal injury including but not limited to severe burns, electrocution, or death. Disconnect the power from the machine before servicing electrical components!

MODIFICATIONS. Modifying the wiring beyond what is shown in the diagram may lead to unpredictable results, including serious injury or fire. This includes the installation of unapproved after-market parts.

WIRE CONNECTIONS. All connections must be tight to prevent wires from loosening during machine operation. Double-check all wires disconnected or connected during any wiring task to ensure tight connections.

CIRCUIT REQUIREMENTS. You MUST follow the requirements at the beginning of this manual when connecting your machine to a power source.

WIRE/COMPONENT DAMAGE. Damaged wires or components increase the risk of serious personal injury, fire, or machine damage. If you notice that any wires or components are damaged while performing a wiring task, replace those wires or components.

MOTOR WIRING. The motor wiring shown in these diagrams is current at the time of printing but may not match your machine. If you find this to be the case, use the wiring diagram inside the motor junction box.















CAPACITORS/INVERTERS. Some capacitors and power inverters store an electrical charge for up to 10 minutes after being disconnected from the power source. To reduce the risk of being shocked, wait at least this long before working on capacitors.

EXPERIENCING DIFFICULTIES. If you are experiencing difficulties understanding the information included in this section, contact our Technical Support at (570) 546-9663.

NOTICE

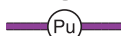
The photos and diagrams included in this section are best viewed in color. You can view these pages in color at www.grizzly.com.

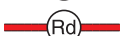
COLOR KEY

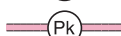
BLACK		BLUE		YELLOW		LIGHT BLUE	
WHITE		BROWN		YELLOW GREEN		BLUE WHITE	
GREEN		GRAY		PURPLE		TURQUOISE	
RED		ORANGE		PINK			



Electrical Components

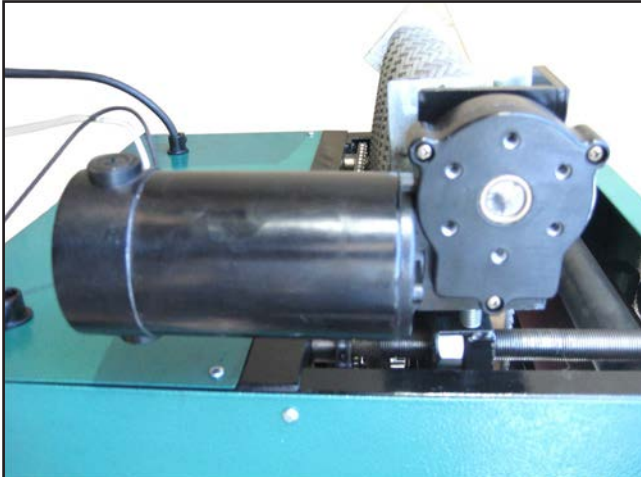

Figure 54. Feed motor.



Figure 57. Capacitor.



Figure 55. Drum motor wiring.

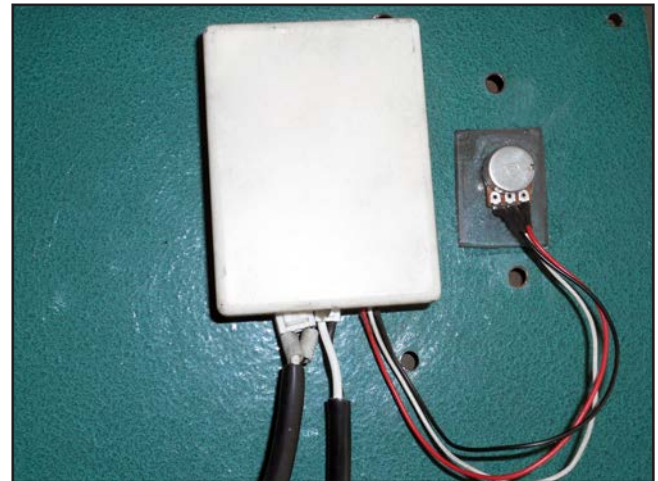

Figure 58. Variable speed control and circuit board.



Figure 56. Switch box wiring.



Wiring Diagram

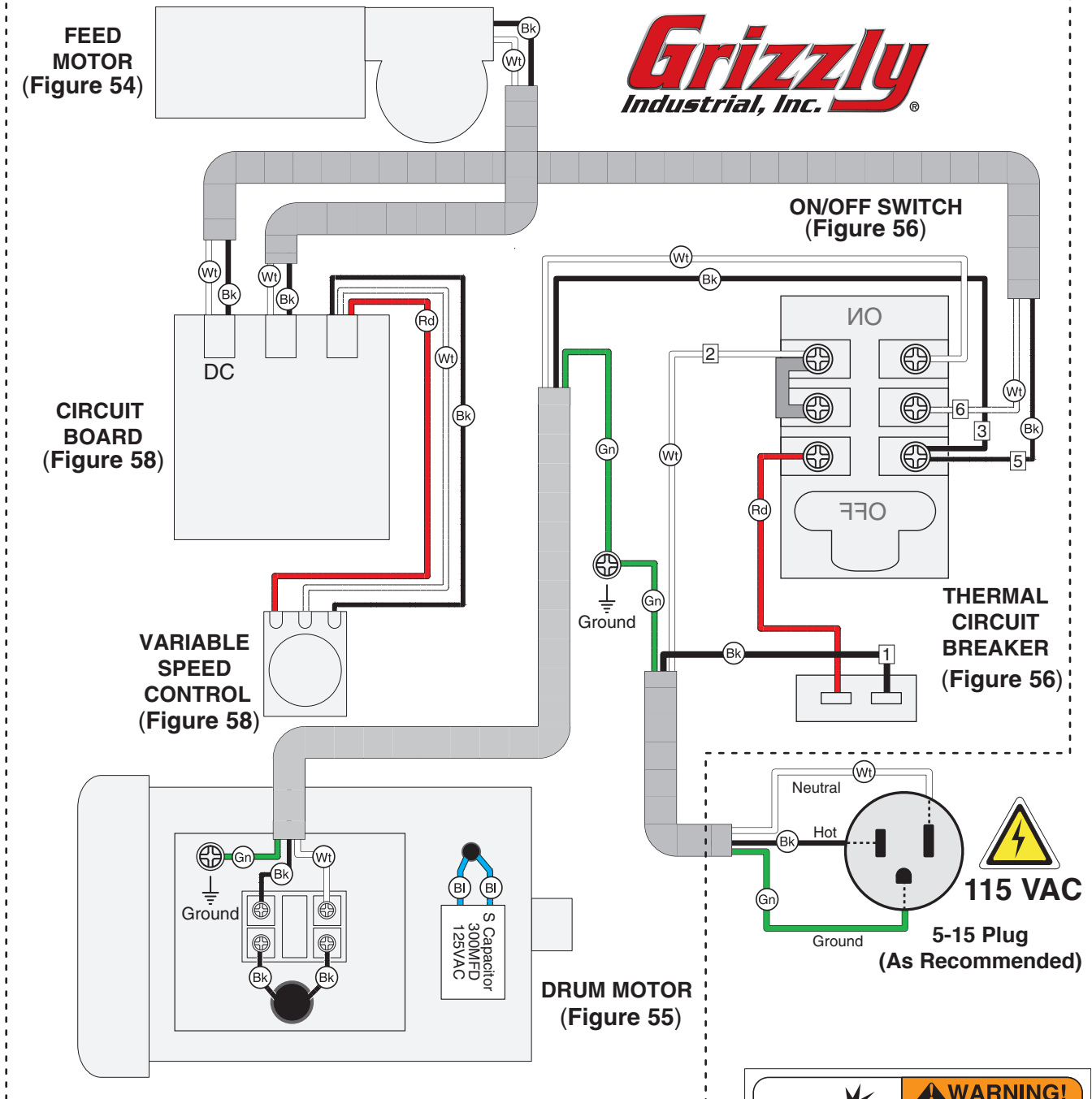

NOTICE

The motor wiring shown here is current at the time of printing, but it may not match your machine. Always use the wiring diagram inside the motor junction box.

WARNING!

SHOCK HAZARD! Disconnect power before working on wiring.



Frame Parts List

REF	PART #	DESCRIPTION
1	P0459001	FRAME
2	P0459002	HEX NUT 5/16-18
3	P0459003	FLAT WASHER 5/16
4	P0459004	SIDE PANEL
4	P0459004	SIDE PANEL
5	P0459005	HANDLE
5-1	P0459005-1	CAP SCREW 5/16-18 X 5/8
6	P0459006	SPROCKET V1
7-1	P0459007-1	SPROCKET SHAFT
7-2	P0459007-2	SPROCKET
8-1	P0459008-1	TABLE LEAD SCREW (1)
8-2	P0459008-2	TABLE LEAD SCREW (2)
8-3	P0459008-3	BUSHING
8-4	P0459008-4	WORM GEAR 25-TEETH
8-5	P0459008-5	KEY 5 X 5 X 10
8-6	P0459008-6	BUSHING
8-7	P0459008-7	FLAT WASHER 1/2
9	P0459009	ELEVATION CHAIN
10	P0459010	FRONT BRACE
10	P0459010	FRONT BRACE
11	P0459011	DEPTH SCALE
12	P0459012	RIGHT SUPPORT ARM
12-1	P0459012-1	PHLP HD SCR 6-32 X 1/4
12-2	P0459012-2	HEX NUT 6-32
13	P0459013	UNIVERSAL DUST PORT 2-1/2"
14	P0459014	TOP COVER
14	P0459014	TOP COVER
14-1	P0459014-1	HINGE
15	P0459015	REAR BRACE
15	P0459015	REAR BRACE
16V2	P0459016V2	REAR PANEL V2.03.09
16V2	P0459016V2	REAR PANEL V2.03.09
17	P0459017	SET SCREW 1/4-20 X 3/8
18	P0459018	MOTOR PULLEY
19	P0459019	KEY 5 X 5 X 30
20V2	P0459020V2	MOTOR 1.5HP 115V 1-PH V2.03.09
20-1	P0459020-1	MOTOR BRACKET
20-2	P0459020-2	S CAP 300M 125V 1-1/2 X 3-1/8
20-3	P0459020-3	CAPACITOR COVER
20-4V2	P0459020-4V2	JUNCTION BOX V2.03.09
20-5	P0459020-5	FAN COVER
20-6	P0459020-6	MOTOR FAN
20-7	P0459020-7	CENTRIFUGAL SWITCH
22	P0459022	HEX BOLT 5/16-18 X 3/4
24	P0459024	FLAT WASHER 5/16
28	P0459028	FLANGE SCREW M3-.6 X 16
29	P0459029	TAP SCREW #8 X 3/8
30-1V2	P0459030-1V2	POWER CORD V2.03.09
30-2V2	P0459030-2V2	MOTOR CORD V2.03.09
30-3V2	P0459030-3V2	VS POWER CORD V2.03.09
30-4V2	P0459030-4V2	DC MOTOR CORD V2.03.09
30-5	P0459030-5	CONTROL WIRE
31V2	P0459031V2	STRAIN RELIEF MGB16 V2.07.11
31-1	P0459031-1	STRAIN RELIEF 3/4"
32V3	P0459032V3	FRONT PANEL V3.01.11

REF	PART #	DESCRIPTION
32V3	P0459032V3	FRONT PANEL V3.01.11
33V2	P0459033V2	PUSH BUTTON SWITCH V2.03.09
34	P0459034	HEX NUT 5/16-18
40	P0459040	FLAT WASHER 5/16
44	P0459044	HEX NUT 1/4-20
45	P0459045	HEX BOLT 1/4-20 X 3/4
46V2	P0459046V2	PC BRD CONSOLE UNIT V2.03.09
54	P0459054	VARIABLE SPEED CTL KNOB
54-1	P0459054-1	POTENTIOMETER
55	P0459055	SPEED INDICATOR LABEL
56V2	P0459056V2	SWITCH BOX V2.03.09
56V2	P0459056V2	SWITCH BOX V2.03.09
57	P0459057	FLANGE SCREW 10-24 X 1/2
57-1	P0459057-1	HEX NUT #10-24
57-2	P0459057-2	PHLP HD SCR 10-24 X 3/8
59	P0459059	EXT TOOTH WASHER 5MM
99	P0459099	HEX WRENCH 3MM
100	P0459100	DUST SCOOP
100	P0459100	DUST SCOOP
101	P0459101	WORM GEAR SHAFT BRACKET
103	P0459103	SHAFT MOUNT
104	P0459104	WORM GEAR
107	P0459107	BUSHING
108	P0459108	HEX BOLT 1/4-20 X 1/2
109	P0459109	COLLAR
110	P0459110	WORM GEAR MOUNT WASHER
111	P0459111	WIRES
112V2	P0459112V2	GEAR COVER V2.07.11
112V2	P0459112V2	GEAR COVER V2.07.11
113	P0459113	CRANK HANDLE
113	P0459113	CRANK HANDLE
114	P0459114	HANDLE
115	P0459115	HEX NUT 3/8-16
117	P0459117	FLAT WASHER 5/16
118	P0459118	HEX BOLT 5/16-18 X 1
119	P0459119	SET SCREW 1/4-20 X 1/4
120	P0459120	OL RELAY YS 20A
121	P0459121	HEX NUT SIZE M11-1
122	P0459122	JUMPER
130	P0459130	PC BOARD COVER
132	P0459132	FRONT ELEVATION CHAIN GUARD
133	P0459133	REAR ELEVATION CHAIN GUARD
134	P0459134	PHLP HD SCR 10-24 X 3/8
135	P0459135	FLAT WASHER #10
136	P0459136	HEX NUT #10-24
137	P0459137	PADLOCK STORAGE HOOK
138	P0459138	SWITCH PADLOCK
209	P0459209	GRIZZLY NAMEPLATE-MINI
209-1	P0459209-1	TAP SCREW #5 X 3/8
211	P0459211	COVER LOCK KNOB
212V3	P0459212V3	MACHINE ID LABEL CSA V3.07.11
212V3	P0459212V3	MACHINE ID LABEL CSA V3.01.11
223	P0459P223	POLAR BEAR LOGO 2-1/2 X 9-1/2
224	P0459P224	POLAR BEAR WHITE TOUCH-UP PAINT
225	P0459P225	MODEL NUMBER LABEL



Drum

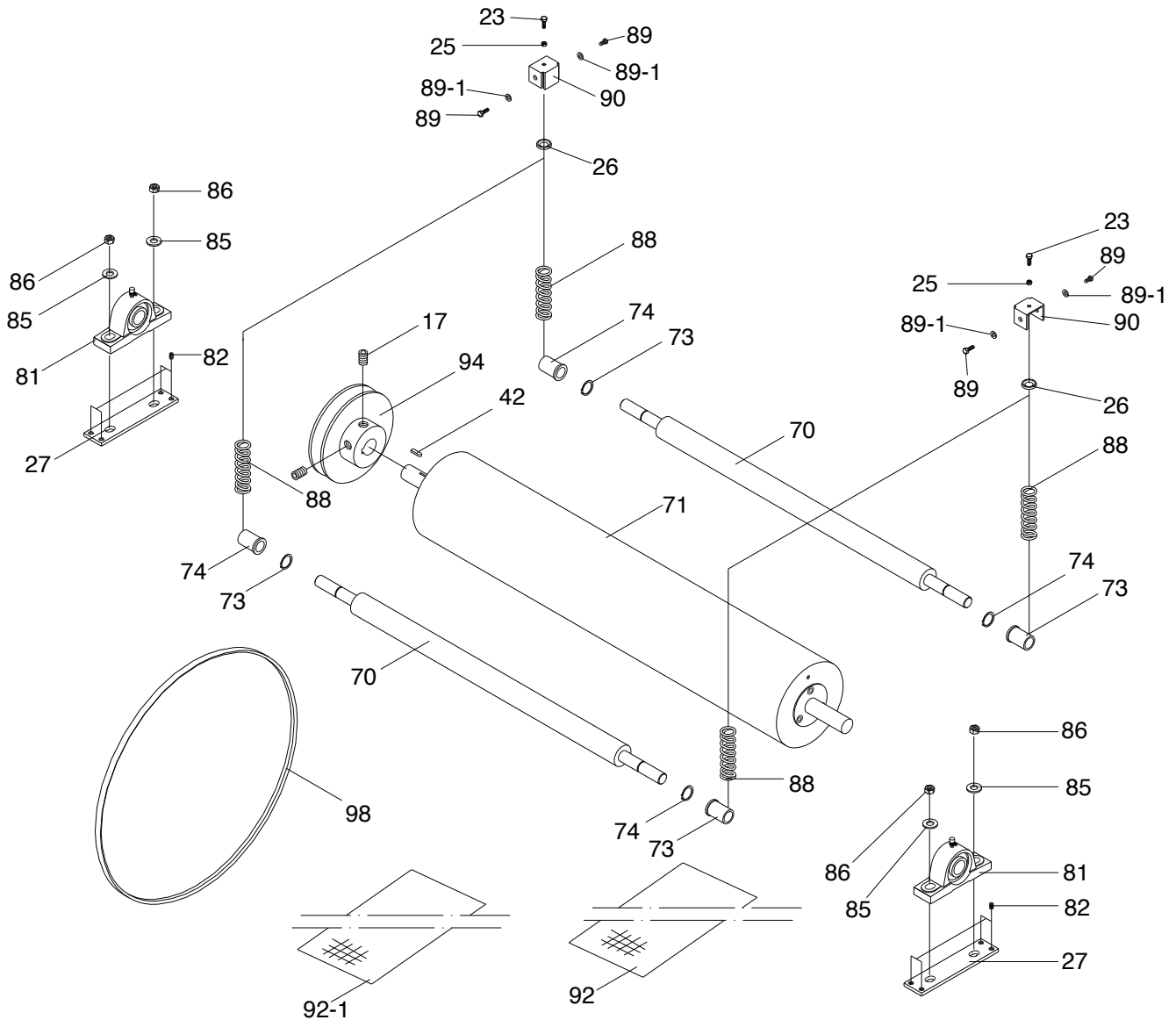

REF	PART #	DESCRIPTION
17	PSS03	SET SCREW 1/4-20 X 3/8
23	PB02	HEX BOLT 1/4-20 X 5/8
25	PN05	HEX NUT 1/4-20
26	P0459026	SPRING PLATE
27	P0459027	ADJUST PLATE
42	PK34M	KEY 5 X 5 X 20
70	P0459070	PRESSURE ROLLER
71	P0459071	SANDING DRUM
73	PR08M	EXT RETAINING RING 19MM
74	P1066062	BUSHING
81	PUCP205	PILLOW BLOCK BEARING UCP205

REF	PART #	DESCRIPTION
82	PSS51	SET SCREW 5/16-24 X 1/2
85	PW02	FLAT WASHER 3/8
86	PLN01	LOCK NUT 3/8-16
88	P0459088	COMP SPRING 24-20-8MM 63L
89	PB51	HEX BOLT 1/4-20 X 3/8
89-1	PW06	FLAT WASHER 1/4
90	P0459090	BRACKET
92	P0459092	HOOK & LOOP SANDBELT
92-1	P0459092-1	HOOK & LOOP DRUM COVER
94	P0459094	DRUM PULLEY
98	PVA36	V-BELT 4L360



Conveyor

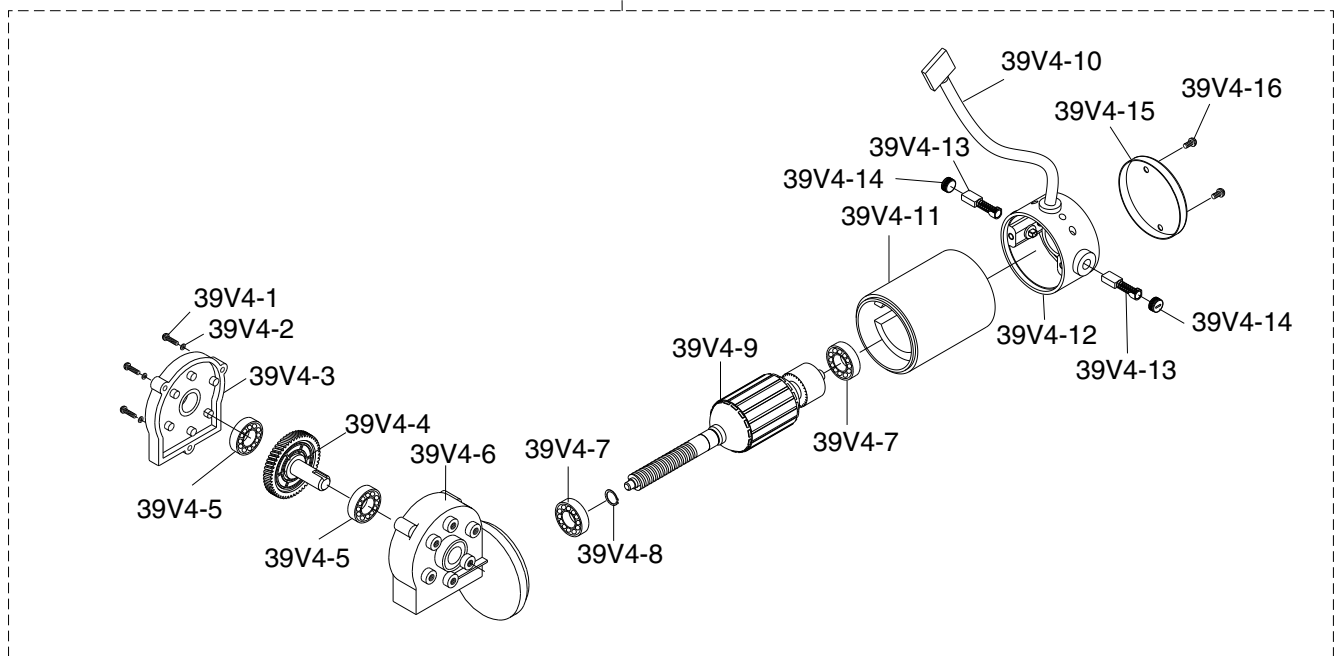
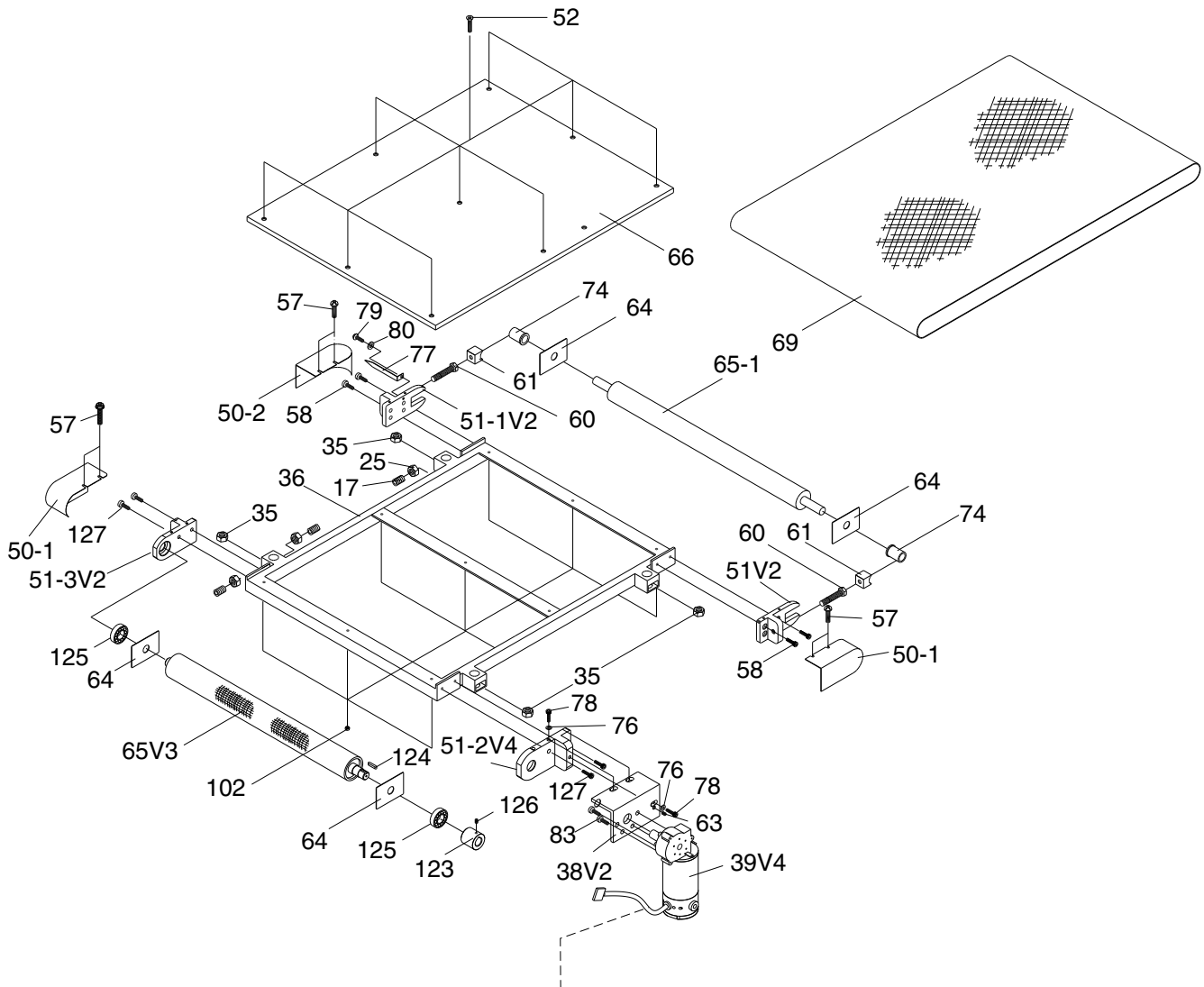

Conveyor Parts List

REF	PART #	DESCRIPTION
17	PSS03	SET SCREW 1/4-20 X 3/8
25	PN05	HEX NUT 1/4-20
35	PN03	HEX NUT 3/4-16
36	P0459036	TABLE FRAME
38V2	P0459038V2	CONVEYOR MOTOR BRACKET V2.03.09
39V4	P0459039V4	DC FEED MOTOR 105W V4.11.09
39V4-1	PS56M	PHLP HD SCR M4-.7 X 16
39V4-2	PLW02M	LOCK WASHER 4MM
39V4-3	P0459039V4-3	END CASE V4.11.09
39V4-4	P0459039V4-4	DRIVE GEAR V4.11.09
39V4-5	P6003ZZ	BALL BEARING 6003ZZ
39V4-6	P0459039V4-6	MAIN CASE V4.11.09
39V4-7	P6000ZZ	BALL BEARING 6000ZZ
39V4-8	PR06M	EXT RETAINING RING 16MM
39V4-9	P0459039V4-9	ARMATURE V4.11.09
39V4-10	P0459039V4-10	FEED MOTOR POWER CORD V4.11.09
39V4-11	P0459039V4-11	STATOR HOUSING V4.11.09
39V4-12	P0459039V4-12	MIDDLE CAP V4.11.09
39V4-13	P0459039V4-13	CARBON BRUSH ASSEMBLY V4.11.09
39V4-14	P0459039V4-14	PLASTIC LOCK CAP V4.11.09
39V4-15	P0459039V4-15	END CAP V4.11.09
39V4-16	PS19M	PHLP HD SCR M5-.8 X 6
50-1	P0459050-1	LEFT ROLLER END GUARD COVER
50-2	P0459050-2	RIGHT ROLLER END GUARD COVER
51V2	P0459051V2	LEFT ROLLER BRACKET V2.07.11
51-1V2	P0459051-1V2	RIGHT FRONT ROLLER BRACKET V2.07.11

REF	PART #	DESCRIPTION
51-2V4	P0459051-2V4	LEFT REAR ROLLER BRACKET V4.01.11
51-3V2	P0459051-3V2	RIGHT REAR ROLLER BRACKET V2.07.11
52	PFH12	FLAT HD SCR 1/4-20 X 1
57	PFS17	FLANGE SCREW 10-24 X 1/2
58	PCAP01	CAP SCREW 1/4-20 X 5/8
60	P0459060	ROLLER BRACKET BOLT
61	P0459061	BUSHING SUPPORT
63	P0459063	SET SCREW 1/4-20 X 3/16
64	P0459064	PLATE
65V3	P0459065V3	DRIVE ROLLER V3.09.09
65-1	P0459065-1	IDLER ROLLER
66	P0459066	TABLE
69	P0459069	CONVEYOR BELT 1220 X 312MM
74	P1066062	BUSHING
76	PW06	FLAT WASHER 1/4
77	P0459077	SCALE POINTER
78	PCAP01	CAP SCREW 1/4-20 X 5/8
79	PS06	PHLP HD SCR 10-24 X 3/8
80	PW03	FLAT WASHER #10
83	PCAP28M	CAP SCREW M6-1 X 15
102	PLN02	LOCK NUT 1/4-20
123	P0459123	COLLAR
124	PK23M	KEY 5 X 5 X 25
125	P6003-2RS	BALL BEARING 6003-2RS
126	PSS11	SET SCREW 1/4-20 X 1/4
127	PCAP06	CAP SCREW 1/4-20 X 1

Label Placement

REF	PART #	DESCRIPTION
55	P0459055	SPEED INDICATOR LABEL
209	G9987	GRIZZLY NAMEPLATE-MINI
212V3	P0459212V3	MACHINE ID LABEL CSA V3.07.11
212V3	P0459P212V3	MACHINE ID LABEL CSA V3.07.11
213	P0459213	RESPIRATOR-GLASSES LABEL
214	PLABEL-22	HAND PINCH IN BELT LABEL
215	P0459215	KICKBACK HAZARD LABEL
216	P0459216	DISCONNECT POWER LABEL
217	PLABEL-14	ELECTRICITY LABEL
218	PLABEL-12B	READY MANUAL HZ LABEL
221	PPAINT-1	GRIZZLY GREEN TOUCH-UP PAINT
222	PPAINT-7	BLACK TOUCH-UP PAINT

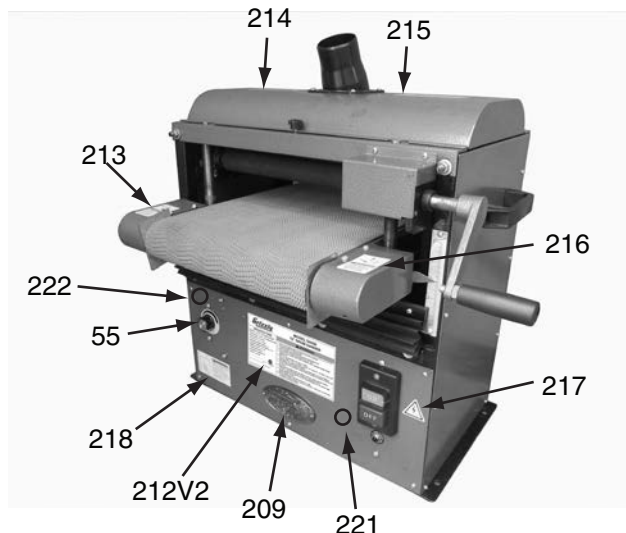

⚠WARNING

Safety labels warn about machine hazards and ways to prevent injury. The owner of this machine **MUST** maintain the original location and readability of the labels on the machine. If any label is removed or becomes unreadable, **REPLACE** that label before using the machine again. Contact Grizzly at (800) 523-4777 or www.grizzly.com to order new labels.





WARRANTY CARD

Name _____
 Street _____
 City _____ State _____ Zip _____
 Phone # _____ Email _____
 Model # _____ Order # _____ Serial # _____

The following information is given on a voluntary basis. It will be used for marketing purposes to help us develop better products and services. **Of course, all information is strictly confidential.**

1. How did you learn about us?

Advertisement Friend Catalog
 Card Deck Website Other:

2. Which of the following magazines do you subscribe to?

<input type="checkbox"/> Cabinetmaker & FDM	<input type="checkbox"/> Popular Science	<input type="checkbox"/> Wooden Boat
<input type="checkbox"/> Family Handyman	<input type="checkbox"/> Popular Woodworking	<input type="checkbox"/> Woodshop News
<input type="checkbox"/> Hand Loader	<input type="checkbox"/> Precision Shooter	<input type="checkbox"/> Woodsmith
<input type="checkbox"/> Handy	<input type="checkbox"/> Projects in Metal	<input type="checkbox"/> Woodwork
<input type="checkbox"/> Home Shop Machinist	<input type="checkbox"/> RC Modeler	<input type="checkbox"/> Woodworker West
<input type="checkbox"/> Journal of Light Cont.	<input type="checkbox"/> Rifle	<input type="checkbox"/> Woodworker's Journal
<input type="checkbox"/> Live Steam	<input type="checkbox"/> Shop Notes	<input type="checkbox"/> Other:
<input type="checkbox"/> Model Airplane News	<input type="checkbox"/> Shotgun News	
<input type="checkbox"/> Old House Journal	<input type="checkbox"/> Today's Homeowner	
<input type="checkbox"/> Popular Mechanics	<input type="checkbox"/> Wood	

3. What is your annual household income?

\$20,000-\$29,000 \$30,000-\$39,000 \$40,000-\$49,000
 \$50,000-\$59,000 \$60,000-\$69,000 \$70,000+

4. What is your age group?

20-29 30-39 40-49
 50-59 60-69 70+

5. How long have you been a woodworker/metalworker?

0-2 Years 2-8 Years 8-20 Years 20+ Years

6. How many of your machines or tools are Grizzly?

0-2 3-5 6-9 10+

7. Do you think your machine represents a good value? Yes No

8. Would you recommend Grizzly Industrial to a friend? Yes No

9. Would you allow us to use your name as a reference for Grizzly customers in your area?
Note: We never use names more than 3 times. Yes No

10. Comments: _____

CUT ALONG DOTTED LINE

FOLD ALONG DOTTED LINE



Place
Stamp
Here



GRIZZLY INDUSTRIAL, INC.
P.O. BOX 2069
BELLINGHAM, WA 98227-2069



FOLD ALONG DOTTED LINE

Send a Grizzly Catalog to a friend:

Name _____
Street _____
City _____ State _____ Zip _____

TAPE ALONG EDGES--PLEASE DO NOT STAPLE

WARRANTY AND RETURNS

Grizzly Industrial, Inc. warrants every product it sells for a period of **1 year** to the original purchaser from the date of purchase. This warranty does not apply to defects due directly or indirectly to misuse, abuse, negligence, accidents, repairs or alterations or lack of maintenance. This is Grizzly's sole written warranty and any and all warranties that may be implied by law, including any merchantability or fitness, for any particular purpose, are hereby limited to the duration of this written warranty. We do not warrant or represent that the merchandise complies with the provisions of any law or acts unless the manufacturer so warrants. In no event shall Grizzly's liability under this warranty exceed the purchase price paid for the product and any legal actions brought against Grizzly shall be tried in the State of Washington, County of Whatcom.

We shall in no event be liable for death, injuries to persons or property or for incidental, contingent, special, or consequential damages arising from the use of our products.

To take advantage of this warranty, contact us by mail or phone and give us all the details. We will then issue you a "Return Number," which must be clearly posted on the outside as well as the inside of the carton. We will not accept any item back without this number. Proof of purchase must accompany the merchandise.

The manufacturers reserve the right to change specifications at any time because they constantly strive to achieve better quality equipment. We make every effort to ensure that our products meet high quality and durability standards and we hope you never need to use this warranty.

Please feel free to write or call us if you have any questions about the machine or the manual.

Thank you again for your business and continued support. We hope to serve you again soon.

grizzly.com[®]
TOOL WEBSITE

Buy Direct and Save with Grizzly[®] – Trusted, Proven and a Great Value!
~Since 1983~

*Visit Our Website Today For
Current Specials!*

**ORDER
24 HOURS A DAY!
1-800-523-4777**

