

Grizzly *Industrial, Inc.*®

MODEL G0453/G0454 15" & 20" MOBILE PLANERS OWNER'S MANUAL



COPYRIGHT © MAY, 2005 BY GRIZZLY INDUSTRIAL, INC., REVISED NOVEMBER, 2012 (TS)
**WARNING: NO PORTION OF THIS MANUAL MAY BE REPRODUCED IN ANY SHAPE
OR FORM WITHOUT THE WRITTEN APPROVAL OF GRIZZLY INDUSTRIAL, INC.**
(FOR MODELS MANUFACTURED SINCE 3/08) #TR7246 PRINTED IN CHINA



WARNING!

This manual provides critical safety instructions on the proper setup, operation, maintenance, and service of this machine/tool. Save this document, refer to it often, and use it to instruct other operators.

Failure to read, understand and follow the instructions in this manual may result in fire or serious personal injury—including amputation, electrocution, or death.

The owner of this machine/tool is solely responsible for its safe use. This responsibility includes but is not limited to proper installation in a safe environment, personnel training and usage authorization, proper inspection and maintenance, manual availability and comprehension, application of safety devices, cutting/sanding/grinding tool integrity, and the usage of personal protective equipment.

The manufacturer will not be held liable for injury or property damage from negligence, improper training, machine modifications or misuse.



WARNING!

Some dust created by power sanding, sawing, grinding, drilling, and other construction activities contains chemicals known to the State of California to cause cancer, birth defects or other reproductive harm. Some examples of these chemicals are:

- **Lead from lead-based paints.**
- **Crystalline silica from bricks, cement and other masonry products.**
- **Arsenic and chromium from chemically-treated lumber.**

Your risk from these exposures varies, depending on how often you do this type of work. To reduce your exposure to these chemicals: Work in a well ventilated area, and work with approved safety equipment, such as those dust masks that are specially designed to filter out microscopic particles.

Table of Contents

INTRODUCTION	2	SECTION 5: ACCESSORIES	28
Manual Accuracy	2	SECTION 6: MAINTENANCE	30
Contact Info.....	2	Schedule.....	30
Machine Description	2	Cleaning & Protecting	30
Identification.....	3	Lubrication	31
Internal Components.....	4	SECTION 7: SERVICE	33
G0453 Machine Data Sheet	5	Troubleshooting	33
G0454 Machine Data Sheet	7	Setting/Replacing Knives.....	36
SECTION 1: SAFETY	9	V-Belt Tensioning/Replacement	37
Safety Instructions for Machinery	9	Table Height Chain Tension	39
Additional Safety Instructions for Planers....	11	Feed Rollers, Chip Breaker & Pressure Bar	
SECTION 2: POWER SUPPLY	12	Heights.....	40
SECTION 3: SETUP	14	Roller Spring Tension	43
Needed for Setup.....	14	Positioning Chip Deflector	43
Unpacking	14	Scale Calibration.....	44
Inventory	15	Anti-Kickback Fingers	44
Cleanup.....	16	Pulley Alignment	45
Site Considerations.....	17	SECTION 8: WIRING	46
Lifting & Moving Base Unit	18	Wiring Safety Instructions	46
Assembly	18	G0453 Wiring Diagram	47
Dust Collection.....	21	G0454 Wiring Diagram	48
Check Gearbox Oil	21	SECTION 9: PARTS	49
Test Run	21	G0453 Headstock	49
Re-Tension V-Belts.....	22	G0453 Table	51
Recommended Adjustments.....	22	G0453 Columns.....	52
SECTION 4: OPERATIONS	23	G0453 Cabinet Stand	53
Operation Overview	23	G0453 Gearbox	55
Planing Tips	24	G0453 Label Placement	56
Workpiece Inspection.....	24	G0454 Headstock	57
Wood Hardness	25	G0454 Table	60
Feed Rate	25	G0454 Columns.....	61
Depth of Cut.....	26	G0454 Cabinet Stand	62
Bed Roller Height.....	26	G0454 Gearbox	64
		G0454 Label Placement	65
		WARRANTY AND RETURNS	69

INTRODUCTION

Manual Accuracy

We are proud to provide a high-quality owner's manual with your new machine!

We made every effort to be exact with the instructions, specifications, drawings, and photographs in this manual. Sometimes we make mistakes, but our policy of continuous improvement also means that **sometimes the machine you receive is slightly different than shown in the manual.**

If you find this to be the case, and the difference between the manual and machine leaves you confused or unsure about something, check our website for an updated version. We post current manuals and manual updates for free on our website at **www.grizzly.com**.

Alternatively, you can call our Technical Support for help. Before calling, make sure you write down the **Manufacture Date** and **Serial Number** from the machine ID label (see below). This information is required for us to provide proper tech support, and it helps us determine if updated documentation is available for your machine.

Grizzly Industrial MODEL GXXXX
MACHINE NAME

SPECIFICATIONS	WARNING!
Motor:	To reduce risk of serious injury when using this machine:
Specification:	1. Read manual before operation.
Specification:	2. Wear safety glasses and respirator.
Specification:	3. Make sure machine is properly adjusted/setup and
Specification:	4. Make sure the motor has stopped and disconnect
Weight:	5. DO NOT expose to rain or dampness.
	6. DO NOT modify this machine in any way.
	7.
	8.
	9. Do not use while under the influence of drugs or alcohol.
	10. Maintain machine carefully to prevent accidents.

Manufacture Date: []

Serial Number: []

Manufactured for Grizzly in Taiwan

Contact Info

We stand behind our machines! If you have questions or need help, contact us with the information below. Before contacting, make sure you get the **serial number** and **manufacture date** from the machine ID label. This will help us help you faster.

Grizzly Technical Support
1815 W. Battlefield
Springfield, MO 65807
Phone: (570) 546-9663
Email: techsupport@grizzly.com

We want your feedback on this manual. What did you like about it? Where could it be improved? Please take a few minutes to give us feedback.

Grizzly Documentation Manager
P.O. Box 2069
Bellingham, WA 98227-2069
Email: manuals@grizzly.com

Machine Description

The Model G0453/G0454 Planer is designed to remove material in precise increments from the surface of natural wood fiber stock to make the workpiece flat.

Once the depth of cut is set, the workpiece is placed on the table and moved into the infeed roller, which pulls the workpiece under the rotating cutterhead where the material is removed. After the workpiece is completely free from the outfeed roller, the depth of cut is increased and the workpiece is passed through the planer again. This process continues until the workpiece is flat and of the correct thickness.



Identification

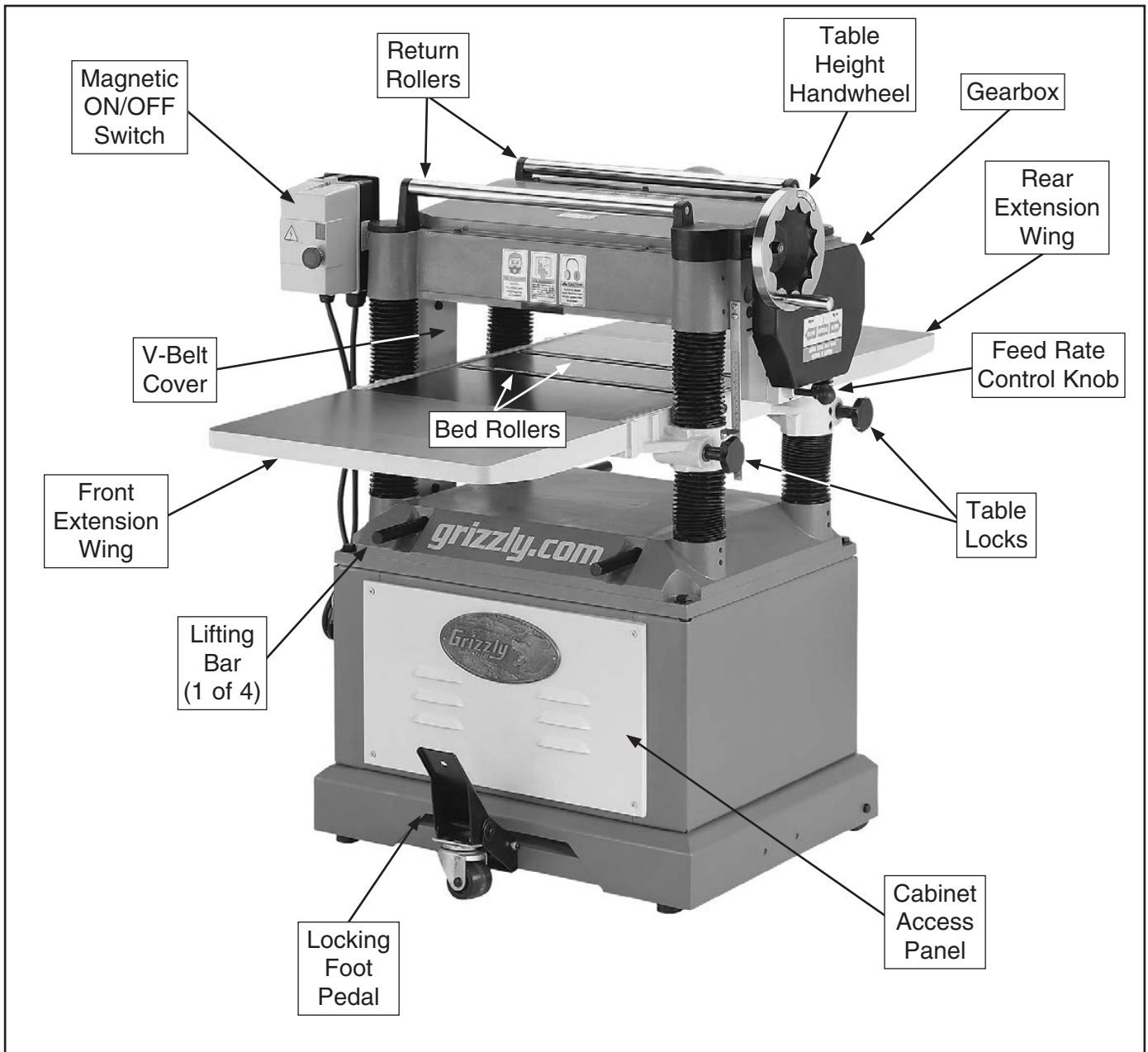

Figure 1. General identification.



Internal Components

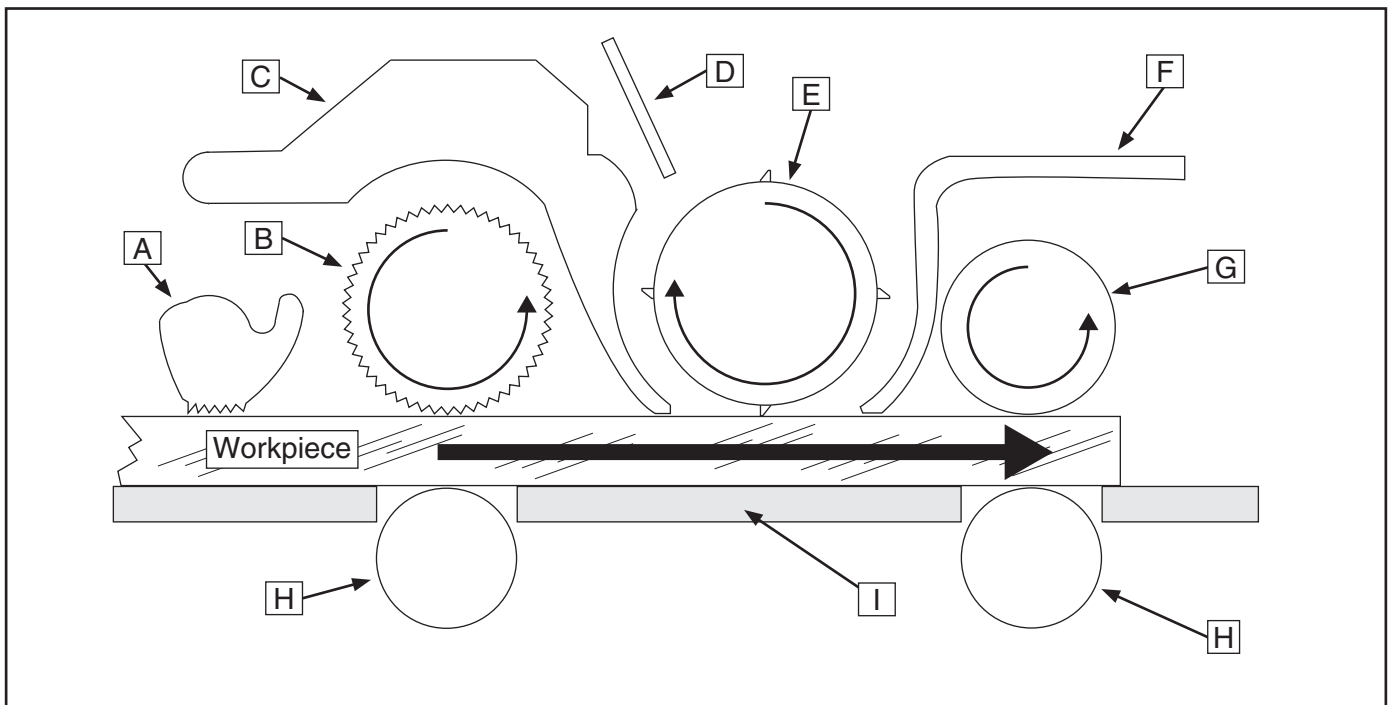

Figure 2. Workpiece path and major planing components (side cutaway view).

- A. Anti-Kickback Fingers:** Provide additional safety for the operator.
- B. Serrated Infeed Roller:** Pulls the workpiece toward the cutterhead.
- C. Chip Breaker:** Breaks off chips created by the cutterhead to prevent tear out and diverts the chips to the dust port.
- D. Chip Deflector:** Directs chips into the dust hood.
- E. Cutterhead:** Holds the knives that remove material from the workpiece.
- F. Pressure Bar:** Stabilizes the workpiece as it leaves the cutterhead and assists in deflecting wood particles toward the dust hood (G0454 only).
- G. Outfeed Rollers:** Pulls the workpiece through the planer.
- H. Table Rollers:** Provide upward pressure on the workpiece enabling the feed rollers to pull the workpiece along.
- I. Planer Table:** Provides a smooth and level path for the workpiece as it moves through the planer.

WARNING

Like all machinery there is potential danger when operating this machine. Accidents are frequently caused by lack of familiarity or failure to pay attention. Use this machine with respect and caution to decrease the risk of operator injury. If normal safety precautions are overlooked or ignored, serious personal injury may occur.





MACHINE DATA SHEET

Customer Service #: (570) 546-9663 · To Order Call: (800) 523-4777 · Fax #: (800) 438-5901

MODEL G0453 15" PLANER

Product Dimensions:

Weight..... 655 lbs.
 Width (side-to-side) x Depth (front-to-back) x Height..... 32-1/2 x 42 x 45-7/8 in.
 Footprint (Length x Width)..... 22-1/2 x 22 in.

Shipping Dimensions:

Type..... Wood Crate
 Content..... Machine
 Weight..... 675 lbs.
 Length x Width x Height..... 30 x 31 x 47 in.
 Must Ship Upright..... Yes

Electrical:

Power Requirement..... 240V, Single-Phase, 60 Hz
 Prewired Voltage..... 240V
 Full-Load Current Rating..... 15A
 Minimum Circuit Size..... 20A
 Connection Type..... Cord & Plug
 Power Cord Included..... Yes
 Power Cord Length..... 5 ft.
 Power Cord Gauge..... 12 AWG
 Plug Included..... No
 Recommended Plug Type..... 6-20
 Switch Type..... Magnetic Switch w/Overload Protection

Motors:

Main

Horsepower..... 3 HP
 Phase..... Single-Phase
 Amps..... 15A
 Speed..... 3450 RPM
 Type..... TEFC Capacitor-Start Induction
 Power Transfer Triple V-Belt Drive
 Bearings..... Sealed & Permanently Lubricated
 Centrifugal Switch/Contacts Type..... External

Main Specifications:

Main Specifications

Planer Size..... 15 in.
 Max. Cut Width..... 15 in.
 Min. Stock Length..... 8 in.
 Min. Stock Thickness..... 3/16 in.
 Max. Stock Thickness..... 8 in.
 Number of Cuts Per Inch..... 63, 42
 Number of Cuts Per Minute..... 15,000
 Cutterhead Speed..... 4800 RPM
 Planing Feed Rate..... 16, 30 FPM
 Max. Cut Depth Planing Full Width..... 3/32 in.
 Max. Cut Depth Planing 6-Inch Wide Board..... 1/8 in.



Cutterhead Info

Cutterhead Type.....	3 Knife
Cutterhead Diameter	3 in.
Number of Knives.....	3
Knife Type.....	HSS, Single-Sided, Solid
Knife Size Length.....	15 in.
Knife Size Width.....	1 in.
Knife Size Thickness.....	1/8 in.
Knife Adjustment.....	Jack Screws

Table Info

Table/Headstock Movement.....	8 in.
Table Bed Size Length.....	20 in.
Table Bed Size Width.....	15 in.
Table Bed Size Thickness.....	1-3/4 in.
Number of Bed Rollers.....	2
Floor-to-Table Height.....	27 – 35 in.
Roller Ext. Table Size Length.....	42 in.
Roller Ext. Table Size Width.....	15 in.
Roller Ext. Table Size Thickness.....	1-3/4 in.

Construction

Table.....	Precision-Ground Cast Iron
Body.....	Cast Iron
Stand.....	Steel
Cutterhead Assembly.....	Steel
Infeed Roller.....	Serrated Steel
Outfeed Roller.....	Rubber-Coated
Paint Type/Finish.....	Powder-Coated

Other

Table/Headstock Locks.....	Yes
Measurement Scale.....	Inch & Metric
Number of Dust Ports.....	1
Dust Port Size.....	4 in.
Mobile Base.....	Built-In

Other Specifications:

Country of Origin	China
Warranty	1 Year
Approximate Assembly & Setup Time	30 Minutes
Serial Number Location	ID Label on Upper Cover
ISO 9001 Factory	No
Certified by a Nationally Recognized Testing Laboratory (NRTL)	Yes





MACHINE DATA SHEET

Customer Service #: (570) 546-9663 · To Order Call: (800) 523-4777 · Fax #: (800) 438-5901

MODEL G0454 20" PLANER

Product Dimensions:

Weight..... 771 lbs.
 Width (side-to-side) x Depth (front-to-back) x Height..... 39-1/2 x 55-1/2 x 45-7/8 in.
 Footprint (Length x Width)..... 29-1/2 x 23-1/2 in.

Shipping Dimensions:

Type..... Wood Crate
 Content..... Machine
 Weight..... 920 lbs.
 Length x Width x Height..... 30 x 39 x 49 in.
 Must Ship Upright..... Yes

Electrical:

Power Requirement..... 240V, Single-Phase, 60 Hz
 Prewired Voltage..... 240V
 Full-Load Current Rating..... 19A
 Minimum Circuit Size..... 30A
 Connection Type..... Cord & Plug
 Power Cord Included..... Yes
 Power Cord Length..... 6-1/2 ft.
 Power Cord Gauge..... 12 AWG
 Plug Included..... Yes
 Included Plug Type..... L6-30
 Switch Type..... Magnetic Switch w/Overload Protection

Motors:

Main

Horsepower..... 5 HP
 Phase..... Single-Phase
 Amps..... 19A
 Speed..... 3450 RPM
 Type..... TEFC Capacitor-Start Induction
 Power Transfer Triple V-Belt Drive
 Bearings..... Sealed & Permanently Lubricated
 Centrifugal Switch/Contacts Type..... External

Main Specifications:

Main Specifications

Planer Size..... 20 in.
 Max. Cut Width..... 20 in.
 Min. Stock Length..... 8 in.
 Min. Stock Thickness..... 3/16 in.
 Max. Stock Thickness..... 8 in.
 Number of Cuts Per Inch..... 104, 83
 Number of Cuts Per Minute..... 20,000
 Cutterhead Speed..... 4800 RPM
 Planing Feed Rate..... 16, 20 FPM
 Max. Cut Depth Planing Full Width..... 1/8 in.
 Max. Cut Depth Planing 6-Inch Wide Board..... 1/8 in.



Cutterhead Info

Cutterhead Type..... 4 Knife
 Cutterhead Diameter 3-1/8 in.
 Number of Knives..... 4
 Knife Type..... HSS, Single-Sided, Solid
 Knife Size Length..... 20 in.
 Knife Size Width..... 1 in.
 Knife Size Thickness..... 1/8 in.
 Knife Adjustment..... Springs or Jack Screws

Table Info

Table/Headstock Movement..... 8 in.
 Table Bed Size Length..... 25-3/4 in.
 Table Bed Size Width..... 20 in.
 Table Bed Size Thickness..... 1-3/4 in.
 Number of Bed Rollers..... 2
 Floor-to-Table Height..... 26-1/2 – 34-1/2 in.
 Roller Ext. Table Size Length..... 55-1/2 in.
 Roller Ext. Table Size Width..... 20 in.
 Roller Ext. Table Size Thickness..... 1-3/4 in.

Construction

Table..... Precision-Ground Cast Iron
 Body..... Cast Iron
 Stand..... Steel
 Cutterhead Assembly..... Steel
 Infeed Roller..... Serrated Steel
 Outfeed Roller..... Rubber-Coated
 Paint Type/Finish..... Powder-Coated

Other

Table/Headstock Locks..... Yes
 Measurement Scale..... Inch & Metric
 Number of Dust Ports..... 1
 Dust Port Size..... 5 in.
 Mobile Base..... Built-In

Other Specifications:

Country of Origin China
 Warranty 1 Year
 Approximate Assembly & Setup Time 30 Minutes
 Serial Number Location ID Label on Upper Cover
 Sound Rating 80 dB
 ISO 9001 Factory No
 Certified by a Nationally Recognized Testing Laboratory (NRTL) Yes



SECTION 1: SAFETY

For Your Own Safety, Read Instruction Manual Before Operating This Machine

The purpose of safety symbols is to attract your attention to possible hazardous conditions. This manual uses a series of symbols and signal words intended to convey the level of importance of the safety messages. The progression of symbols is described below. Remember that safety messages by themselves do not eliminate danger and are not a substitute for proper accident prevention measures. Always use common sense and good judgment.



Indicates an imminently hazardous situation which, if not avoided, **WILL** result in death or serious injury.



Indicates a potentially hazardous situation which, if not avoided, **COULD** result in death or serious injury.



Indicates a potentially hazardous situation which, if not avoided, **MAY** result in minor or moderate injury. It may also be used to alert against unsafe practices.

NOTICE

Alerts the user to useful information about proper operation of the machine to avoid machine damage.

Safety Instructions for Machinery

WARNING

OWNER'S MANUAL. Read and understand this owner's manual **BEFORE** using machine.

TRAINED OPERATORS ONLY. Untrained operators have a higher risk of being hurt or killed. Only allow trained/supervised people to use this machine. When machine is not being used, disconnect power, remove switch keys, or lock-out machine to prevent unauthorized use—especially around children. Make your workshop kid proof!

DANGEROUS ENVIRONMENTS. Do not use machinery in areas that are wet, cluttered, or have poor lighting. Operating machinery in these areas greatly increases the risk of accidents and injury.

MENTAL ALERTNESS REQUIRED. Full mental alertness is required for safe operation of machinery. Never operate under the influence of drugs or alcohol, when tired, or when distracted.

ELECTRICAL EQUIPMENT INJURY RISKS. You can be shocked, burned, or killed by touching live electrical components or improperly grounded machinery. To reduce this risk, only allow qualified service personnel to do electrical installation or repair work, and always disconnect power before accessing or exposing electrical equipment.

DISCONNECT POWER FIRST. Always disconnect machine from power supply **BEFORE** making adjustments, changing tooling, or servicing machine. This prevents an injury risk from unintended startup or contact with live electrical components.

EYE PROTECTION. Always wear ANSI-approved safety glasses or a face shield when operating or observing machinery to reduce the risk of eye injury or blindness from flying particles. Everyday eyeglasses are **NOT** approved safety glasses.



WARNING

WEARING PROPER APPAREL. Do not wear clothing, apparel or jewelry that can become entangled in moving parts. Always tie back or cover long hair. Wear non-slip footwear to reduce risk of slipping and losing control or accidentally contacting cutting tool or moving parts.

HAZARDOUS DUST. Dust created by machinery operations may cause cancer, birth defects, or long-term respiratory damage. Be aware of dust hazards associated with each workpiece material. Always wear a NIOSH-approved respirator to reduce your risk.

HEARING PROTECTION. Always wear hearing protection when operating or observing loud machinery. Extended exposure to this noise without hearing protection can cause permanent hearing loss.

REMOVE ADJUSTING TOOLS. Tools left on machinery can become dangerous projectiles upon startup. Never leave chuck keys, wrenches, or any other tools on machine. Always verify removal before starting!

USE CORRECT TOOL FOR THE JOB. Only use this tool for its intended purpose—do not force it or an attachment to do a job for which it was not designed. Never make unapproved modifications—modifying tool or using it differently than intended may result in malfunction or mechanical failure that can lead to personal injury or death!

AWKWARD POSITIONS. Keep proper footing and balance at all times when operating machine. Do not overreach! Avoid awkward hand positions that make workpiece control difficult or increase the risk of accidental injury.

CHILDREN & BYSTANDERS. Keep children and bystanders at a safe distance from the work area. Stop using machine if they become a distraction.

GUARDS & COVERS. Guards and covers reduce accidental contact with moving parts or flying debris. Make sure they are properly installed, undamaged, and working correctly BEFORE operating machine.

FORCING MACHINERY. Do not force machine. It will do the job safer and better at the rate for which it was designed.

NEVER STAND ON MACHINE. Serious injury may occur if machine is tipped or if the cutting tool is unintentionally contacted.

STABLE MACHINE. Unexpected movement during operation greatly increases risk of injury or loss of control. Before starting, verify machine is stable and mobile base (if used) is locked.

USE RECOMMENDED ACCESSORIES. Consult this owner's manual or the manufacturer for recommended accessories. Using improper accessories will increase the risk of serious injury.

UNATTENDED OPERATION. To reduce the risk of accidental injury, turn machine **OFF** and ensure all moving parts completely stop before walking away. Never leave machine running while unattended.

MAINTAIN WITH CARE. Follow all maintenance instructions and lubrication schedules to keep machine in good working condition. A machine that is improperly maintained could malfunction, leading to serious personal injury or death.

DAMAGED PARTS. Regularly inspect machine for damaged, loose, or mis-adjusted parts—or any condition that could affect safe operation. Immediately repair/replace BEFORE operating machine. For your own safety, DO NOT operate machine with damaged parts!

MAINTAIN POWER CORDS. When disconnecting cord-connected machines from power, grab and pull the plug—NOT the cord. Pulling the cord may damage the wires inside. Do not handle cord/plug with wet hands. Avoid cord damage by keeping it away from heated surfaces, high traffic areas, harsh chemicals, and wet/damp locations.

EXPERIENCING DIFFICULTIES. If at any time you experience difficulties performing the intended operation, stop using the machine! Contact our Technical Support at (570) 546-9663.



WARNING

Additional Safety Instructions for Planers

OWNER'S MANUAL. This machine presents significant safety hazards to untrained users. Read and understand this entire manual before starting the planer.

KICKBACK. Be familiar with kickback. Kickback happens when the workpiece is thrown towards the operator at a high rate of speed. Until you have a clear understanding of kickback and how it occurs, DO NOT operate this planer!

REACHING INSIDE PLANER. To avoid serious personal injury from spinning knives, never remove guards or reach inside the planer while it is connected to power.

DULL/DAMAGED KNIVES. Only use sharp, undamaged knives. Kickback may occur and the cutting results will be poor if the planer is operated with dull or damaged knives.

BODY PLACEMENT. To avoid getting hit if a kickback occurs, always stand to one side of the planer during the entire operation.

PLANING CORRECT MATERIAL. Only plane natural wood stock with this planer. DO NOT plane MDF, plywood, laminates or other synthetic materials that can break up inside the planer and cause injury hazards.

GRAIN DIRECTION. Planing across the grain is hard on the planer and may cause kickback. Always plane in the same direction or at a slight angle with the wood grain.

LOOKING INSIDE PLANER. Wood chips fly around inside the planer at a high rate of speed during operation. To avoid injury from flying material, DO NOT look inside the planer during operation.

CUTTING LIMITATIONS. To reduce the risk of kickback hazards or damage to the machine, always operate within the published capacities found in the Data Sheet (beginning on Page 5) for this planer.

CLEAN STOCK. Planing stock with nails, staples, or loose knots may cause debris to be thrown at the operator at a high rate of speed and will damage the cutterhead knives. To avoid these hazards, always thoroughly inspect and prepare the workpieces.

CLEARING JAMS. To avoid serious personal injury from the spinning cutterhead, always stop the planer and disconnect it from power before removing jammed workpieces.

INFEED ROLLER CLEARANCE. The infeed roller is designed to pull material into the spinning cutterhead. To avoid serious personal injury, always keep hands, clothing, jewelry, and long hair away from the infeed roller during operation.

DISCONNECT BEFORE ADJUSTMENTS. To avoid unexpected start-up and serious personal injury, always disconnect the planer from power before performing adjustments, maintenance, or service.

CAUTION

No list of safety guidelines can be complete. Every shop environment is different. Always consider safety first, as it applies to your individual working conditions. Use this and other machinery with caution and respect. Failure to do so could result in serious personal injury, damage to equipment, or poor work results.



SECTION 2: POWER SUPPLY

Availability

Before installing the machine, consider the availability and proximity of the required power supply circuit. If an existing circuit does not meet the requirements for this machine, a new circuit must be installed. To minimize the risk of electrocution, fire, or equipment damage, installation work and electrical wiring must be done by an electrician or qualified service personnel in accordance with all applicable codes and standards.

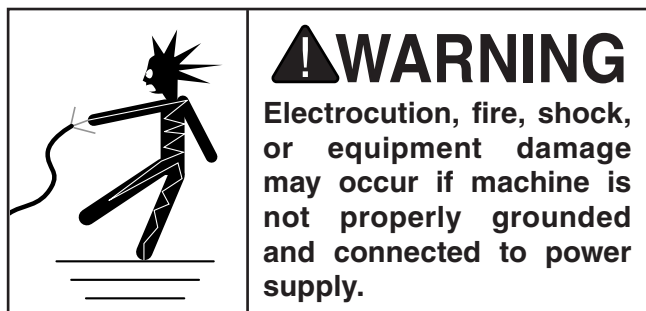

Full-Load Current Rating

The full-load current rating is the amperage a machine draws at 100% of the rated output power. On machines with multiple motors, this is the amperage drawn by the largest motor or sum of all motors and electrical devices that might operate at one time during normal operations.

G0453 Full-Load Current Rating at 220V 15 Amps

G0454 Full-Load Current Rating at 220V 25 Amps

The full-load current is not the maximum amount of amps that the machine will draw. If the machine is overloaded, it will draw additional amps beyond the full-load rating.

If the machine is overloaded for a sufficient length of time, damage, overheating, or fire may result—especially if connected to an undersized circuit. To reduce the risk of these hazards, avoid overloading the machine during operation and make sure it is connected to a power supply circuit that meets the specified circuit requirements.

G0453 220V Circuit Requirements

This machine is prewired to operate on a power supply circuit that has a verified ground and meets the following requirements:

Nominal Voltage 220V/240V
Cycle 60 Hz
Phase 1-Phase
Circuit Rating 20 Amps
Plug/Receptacle NEMA 6-20
Cord 3-Wire, 12 AWG, 300VAC, “S”-Type

G0454 220V Circuit Requirements

This machine is prewired to operate on a power supply circuit that has a verified ground and meets the following requirements:

Nominal Voltage 220V/240V
Cycle 60 Hz
Phase 1-Phase
Circuit Rating 30 Amps
Plug/Receptacle NEMA L6-30
Cord 3-Wire, 12 AWG, 300VAC, “S”-Type

A power supply circuit includes all electrical equipment between the breaker box or fuse panel in the building and the machine. The power supply circuit used for this machine must be sized to safely handle the full-load current drawn from the machine for an extended period of time. (If this machine is connected to a circuit protected by fuses, use a time delay fuse marked D.)



Note: *Circuit requirements in this manual apply to a dedicated circuit—where only one machine will be running on the circuit at a time. If machine will be connected to a shared circuit where multiple machines may be running at the same time, consult an electrician or qualified service personnel to ensure circuit is properly sized for safe operation.*



Grounding Instructions

This machine **MUST** be grounded. In the event of certain malfunctions or breakdowns, grounding reduces the risk of electric shock by providing a path of least resistance for electric current.

The plug specified under "Circuit Requirements" on the previous page has a grounding prong that must be attached to the equipment-grounding wire on the included power cord. The plug must only be inserted into a matching receptacle (see the following figures) that is properly installed and grounded in accordance with all local codes and ordinances.

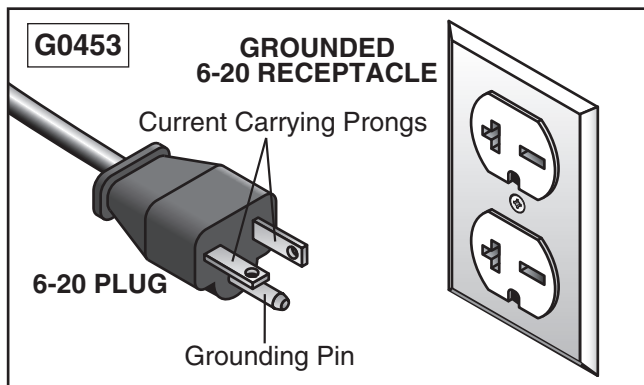

Figure 3. Typical 6-20 plug and receptacle.

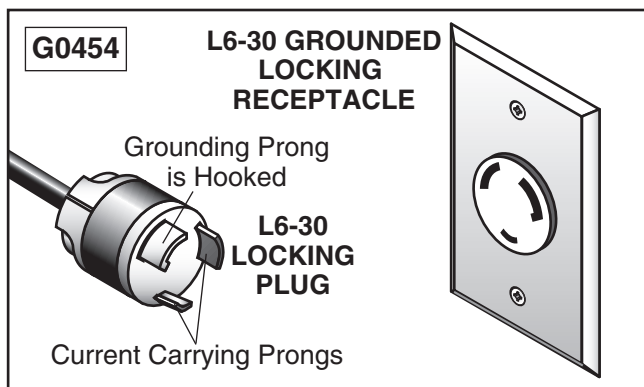

Figure 4. Typical L6-30 plug and receptacle.

NOTICE

No adapter is available or should be used with this machine. If the machine must be reconnected for use on a different type of electric circuit, the reconnection should be made by qualified service personnel; and after reconnection, the machine must comply with all local codes and ordinances.

! WARNING

Serious injury could occur if you connect machine to power before completing setup process. DO NOT connect to power until instructed later in this manual.

Improper connection of the equipment-grounding wire can result in a risk of electric shock. The wire with green insulation (with or without yellow stripes) is the equipment-grounding wire. If repair or replacement of the power cord or plug is necessary, do not connect the equipment-grounding wire to a live (current carrying) terminal.

Check with a qualified electrician or service personnel if you do not understand these grounding requirements, or if you are in doubt about whether the tool is properly grounded. If you ever notice that a cord or plug is damaged or worn, disconnect it from power, and immediately replace it with a new one.

Extension Cords

We do not recommend using an extension cord with this machine. If you must use an extension cord, only use it if absolutely necessary and only on a temporary basis.

Extension cords cause voltage drop, which can damage electrical components and shorten motor life. Voltage drop increases as the extension cord size gets longer and the gauge size gets smaller (higher gauge numbers indicate smaller sizes).

Any extension cord used with this machine must be in good condition and contain a ground wire and matching plug/receptacle. Additionally, it must meet the following size requirements:

G0453 Minimum Gauge Size 12 AWG
G0454 Minimum Gauge Size 10 AWG
Maximum Length (Shorter is Better).....50 ft.



SECTION 3: SETUP

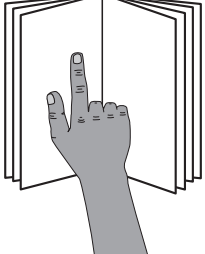

!WARNING
This machine presents serious injury hazards to untrained users. Read through this entire manual to become familiar with the controls and operations before starting the machine!



!WARNING
Wear safety glasses during the entire setup process!

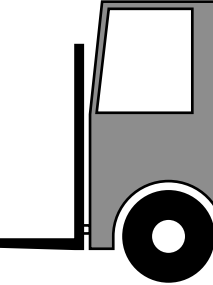

!WARNING
The Model G0453/G0454 is a heavy machine. Serious personal injury may occur if safe moving methods are not used. To be safe, get assistance and use power equipment to move the shipping crate and remove the machine from the crate.

Needed for Setup

The following are needed to complete the setup process, but are not included with your machine:

Description	Qty
• Assistant.....	1
• Safety Glasses	1 Per Person
• Forklift (rated for at least 1000 lbs.).....	1
• Shop Rags & Cleaning Solvent..	As Needed
• Floor Mounting Hardware.....	As Needed
• Straightedge 4'	1
• Dust Collection System	1
• 4" or 5" Dust Hose w/Clamps	1

Unpacking

Your machine was carefully packaged for safe transportation. Remove the packaging materials from around your machine and inspect it. If you discover the machine is damaged, *please immediately call Customer Service at (570) 546-9663 for advice.*

Save the containers and all packing materials for possible inspection by the carrier or its agent. *Otherwise, filing a freight claim can be difficult.*

When you are completely satisfied with the condition of your shipment, inventory the contents.



!WARNING
SUFFOCATION HAZARD!
Keep children and pets away from plastic bags or packing materials shipped with this machine.



Inventory

The following is a list of items shipped with your machine. Before beginning setup, lay these items out and inventory them.

If any non-proprietary parts are missing (e.g. a nut or a washer), we will gladly replace them; or for the sake of expediency, replacements can be obtained at your local hardware store.

Box Inventory: (Figure 5)	Qty
A. Planer (Not Shown)	1
B. Dust Hood	1
C. Foot Pedal	1
D. Handwheel	1
E. Caster	1
F. Extension Wings	2

G0453 Hardware and Tools (not shown)

- Set Screws M8-1.25 x 20 (Wings)..... 4
- Hex Bolts M8-1.25 x 30 (Wings)..... 6
- Flat Washers 8mm (Wings)..... 6
- Lock Washers 8mm (Wings) 6
- Handwheel Bushing 1
- Handwheel Handle..... 1
- Hex Nut M12-1.75 (Handwheel)..... 1
- Flat Washer 12mm (Handwheel)..... 1
- Hex Bolts M6-1 x 10 (Dust Hood) 3
- Flat Washers 6mm (Dust Hood)..... 6
- Hex Nuts M6-1 (Dust Hood)..... 3
- Cap Screws M8-1.25 x 20 (Dust Hood)..... 3
- Hex Wrenches 2.5, 3, 4, 6mm..... 1 Each
- Wrenches 10/12, 14/17, 17/19mm 1 Each
- Knife Gauge 1

G0454 Hardware and Tools (not shown)

- Set Screws M8-1.25 x 20 (Wings)..... 6
- Hex Bolts M8-1.25 x 30 (Wings)..... 6
- Flat Washers 8mm (Wings)..... 6
- Lock Washers 8mm (Wings) 6
- Handwheel Bushing 1
- Handwheel Handle..... 1
- Hex Nut M12-1.75 (Handwheel)..... 1
- Flat Washer 12mm (Handwheel)..... 1
- Flange Bolts M6-1 x 12 (Dust Hood)..... 6
- Hex Wrenches 3, 4, 5, 6mm..... 1 Each
- Wrenches 8/10, 12/14, 17/19mm..... 1 Each
- Knife Gauge 1

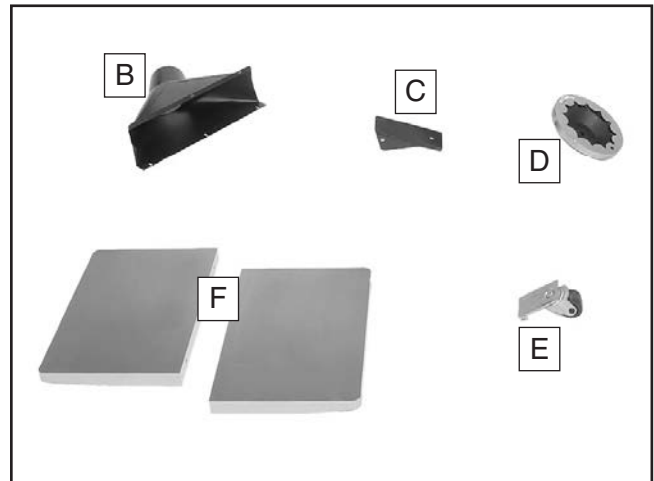

Figure 5. Model G0453/G0454 inventory.

NOTICE

If you cannot find an item on this list, carefully check around/inside the machine and packaging materials. Often, these items get lost in packaging materials while unpacking or they are pre-installed at the factory.



Cleanup

The unpainted surfaces of your machine are coated with a heavy-duty rust preventative that prevents corrosion during shipment and storage. This rust preventative works extremely well, but it will take a little time to clean.

Be patient and do a thorough job cleaning your machine. The time you spend doing this now will give you a better appreciation for the proper care of your machine's unpainted surfaces.

There are many ways to remove this rust preventative, but the following steps work well in a wide variety of situations. Always follow the manufacturer's instructions with any cleaning product you use and make sure you work in a well-ventilated area to minimize exposure to toxic fumes.

Before cleaning, gather the following:

- Disposable rags
- Cleaner/degreaser (WD•40 works well)
- Safety glasses & disposable gloves
- Plastic paint scraper (optional)

Basic steps for removing rust preventative:

1. Put on safety glasses.
2. Coat the rust preventative with a liberal amount of cleaner/degreaser, then let it soak for 5–10 minutes.
3. Wipe off the surfaces. If your cleaner/degreaser is effective, the rust preventative will wipe off easily. If you have a plastic paint scraper, scrape off as much as you can first, then wipe off the rest with the rag.
4. Repeat **Steps 2–3** as necessary until clean, then coat all unpainted surfaces with a quality metal protectant to prevent rust.

	⚠ WARNING Gasoline and petroleum products have low flash points and can explode or cause fire if used to clean machinery. Avoid using these products to clean machinery.
--	--

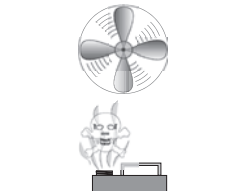
	⚠ CAUTION Many cleaning solvents are toxic if inhaled. Only work in a well-ventilated area.
--	---

NOTICE Avoid harsh solvents like acetone or brake parts cleaner that may damage painted surfaces. Always test on a small, inconspicuous location first.

T23692—Orange Power Degreaser

A great product for removing the waxy shipping grease from the **non-painted** parts of the machine during clean up.

<p>Call 1-800-523-4777 To Order</p>	
--	---



Site Considerations

Weight Load

Refer to the **Machine Data Sheet** for the weight of your machine. Make sure that the surface upon which the machine is placed will bear the weight of the machine, additional equipment that may be installed on the machine, and the heaviest workpiece that will be used. Additionally, consider the weight of the operator and any dynamic loading that may occur when operating the machine.

Space Allocation

Consider the largest size of workpiece that will be processed through this machine and provide enough space around the machine for adequate operator material handling or the installation of auxiliary equipment. With permanent installations, leave enough space around the machine to open or remove doors/covers as required by the maintenance and service described in this manual. **See below for required space allocation.**

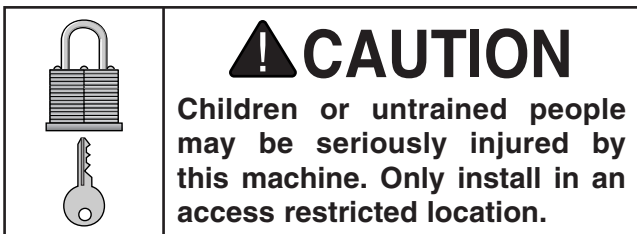

Physical Environment

The physical environment where the machine is operated is important for safe operation and longevity of machine components. For best results, operate this machine in a dry environment that is free from excessive moisture, hazardous chemicals, airborne abrasives, or extreme conditions. Extreme conditions for this type of machinery are generally those where the ambient temperature range exceeds 41°–104°F; the relative humidity range exceeds 20%–95% (non-condensing); or the environment is subject to vibration, shocks, or bumps.

Electrical Installation

Place this machine near an existing power source. Make sure all power cords are protected from traffic, material handling, moisture, chemicals, or other hazards. Make sure to leave enough space around machine to disconnect power supply or apply a lockout/tagout device, if required.

Lighting

Lighting around the machine must be adequate enough that operations can be performed safely. Shadows, glare, or strobe effects that may distract or impede the operator must be eliminated.

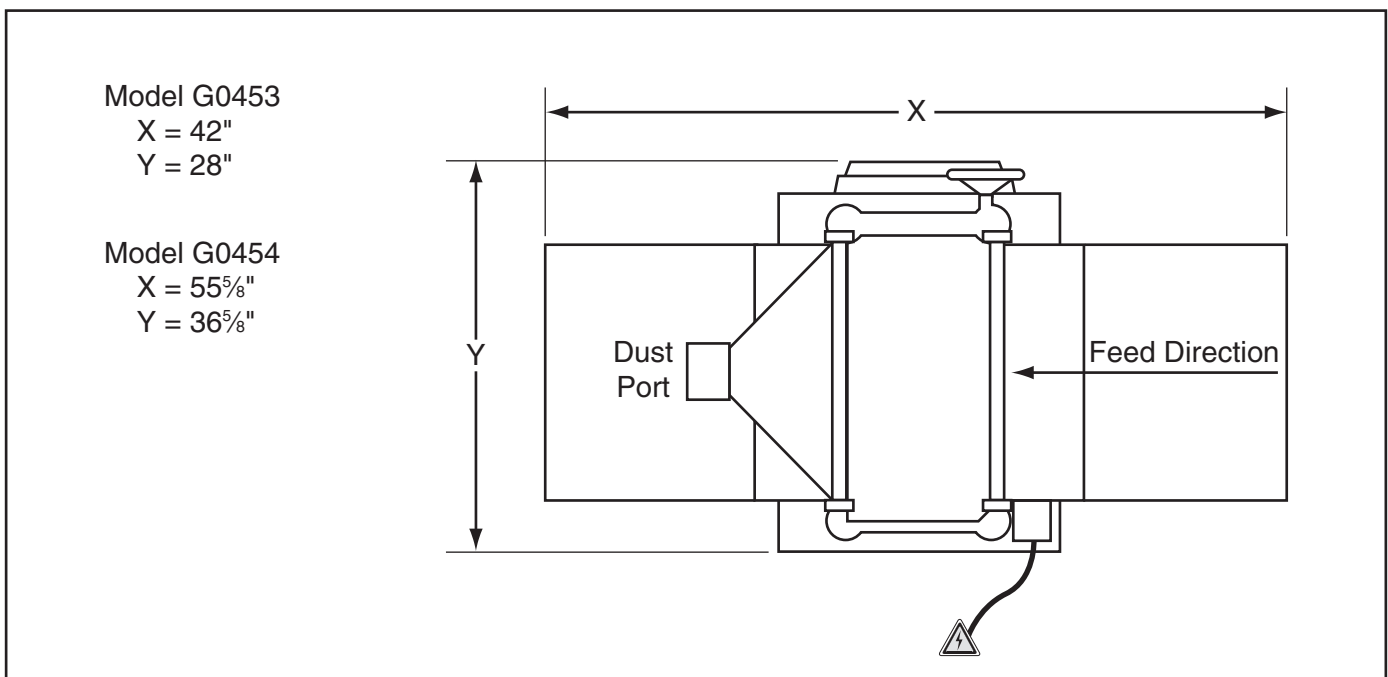
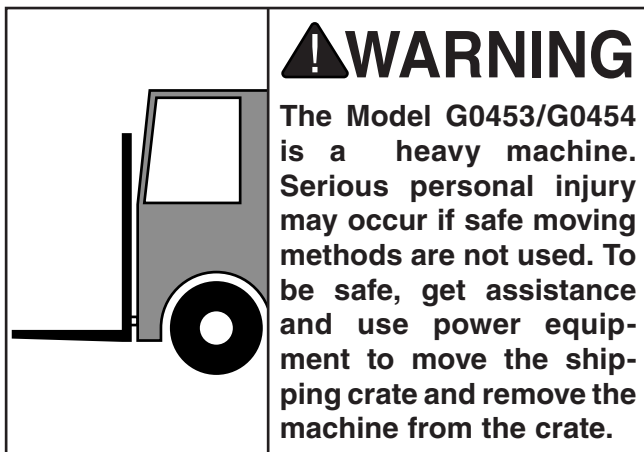

Figure 6. Minimum working clearances.



Lifting & Moving Base Unit



The cabinet stand on the Model G0453/G0454 planer is equipped with four lifting bars that pull out in order to lift and place the planer, as shown in **Figure 7**.

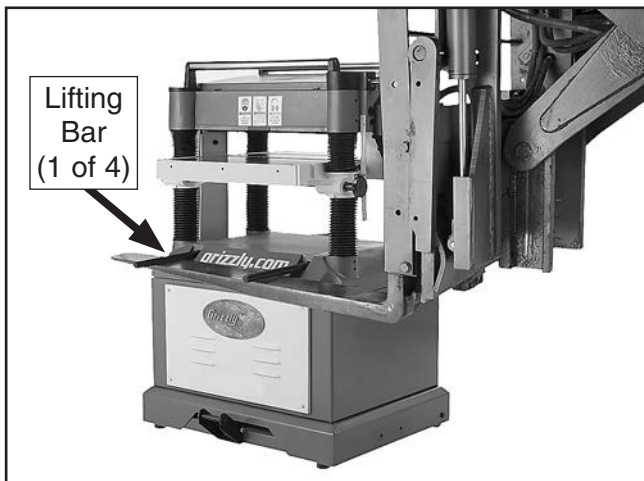

Figure 7. Lifting the planer with a forklift.

Tip: When positioning the lift forks, place shop rags or cardboard between the forks and the cabinet stand to avoid scratching the paint.

Assembly

To assemble your planer:

1. Install M8-1.25 x 20 set screws in the holes in the bottom of the wings (see **Figure 8**).

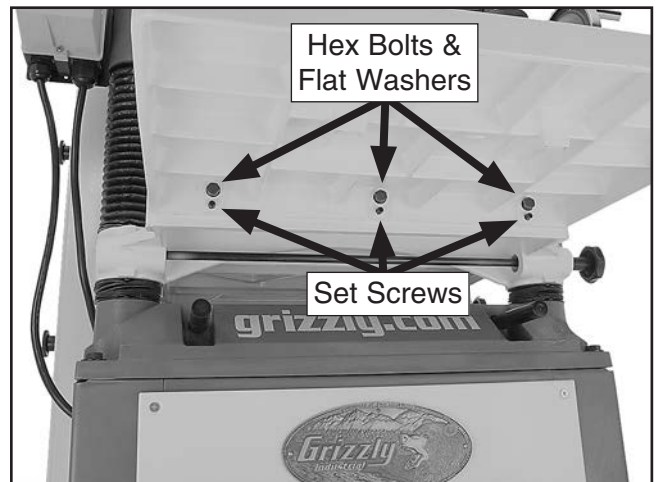

Figure 8. Front extension wing installed (Model G0454 shown).

2. Attach the table extension wings to the planer table with the M8-1.25 x 30 hex bolts, 8mm lock washers, and 8mm flat washers, as shown in **Figure 8**, but do not fully tighten the bolts at this time.
3. Using a straightedge as a guide and the set screws for leveling control, position the extension wings even with the table, then fully tighten the hex bolts.

Note: Be aware that the bed rollers will give you a false reading with your straightedge if they are raised above the table. Move them down or work around them when leveling the extension wings.



4. Place the bushing on the handwheel shaft.
5. Insert the key into the shaft keyway.
6. Screw the handle into the handwheel.
7. Place the handwheel on the shaft and secure it with the M12-1.75 hex nut and 12mm flat washer, as shown in **Figure 9**.



Figure 9. Installing the table height handwheel.

8. **Model G0453:** Attach the dust hood to the top of the planer with the M6-1 x 10 hex bolts, 6mm flat washers, and M6-1 hex nuts as shown in **Figure 10**, then attach the bottom of the dust hood to the planer with the M8-1.25 x 20 cap screws.

Note: You will need to reach into the dust hood to get access for fastening the nuts.



Figure 10. Dust hood attached.

Model G0454: Attach the dust hood with the provided M6-1 x 12 flange bolts.

9. Remove the two cap screws already installed on the left-hand side of the head casting.
10. Attach the switch bracket with the two cap screws, as shown in **Figure 11**.

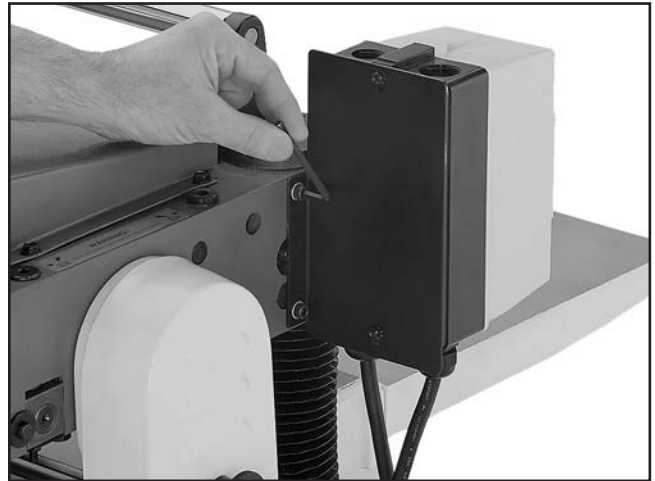

Figure 11. Attaching magnetic switch.

NOTICE

Before starting your machine, you must make sure the gearbox has the proper amount of oil to avoid machine damage.

11. Remove the gearbox fill plug (see **Figure 12**).

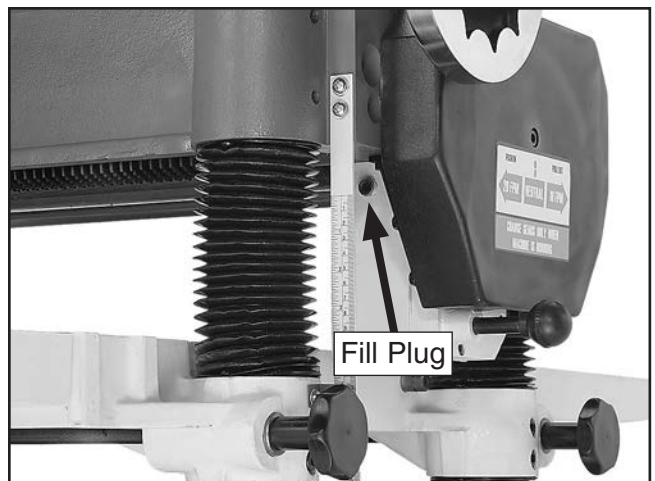

Figure 12. Gearbox fill plug.



- Using the short end of a clean hex wrench, dip it inside the fill hole and remove it.

—If the end of the hex wrench is coated with oil, then the gearbox oil level is okay. Replace the fill plug and skip to the next section.

—If the end of the hex wrench is not coated with oil, then you need to add more oil. Refer to **Page 32** for instructions on how to do this.

NOTICE

Replace the gearbox oil after the first 20 hours of operation. This is a normal break-in procedure.

- Remove the pin and hex bolt that are already mounted in the foot pedal bracket.
- Align the caster assembly with the mounting holes in the foot pedal bracket.

- Insert the hex bolt into the hole in the back side of the caster assembly, and tighten the bolt just enough for it to be snug without hampering the pivot action of the caster.
- Install the foot pedal to the caster and secure together by inserting the pin between the two parts.
- Lock the caster and pedal in place with the E-clip and washers, as shown in **Figure 13**.

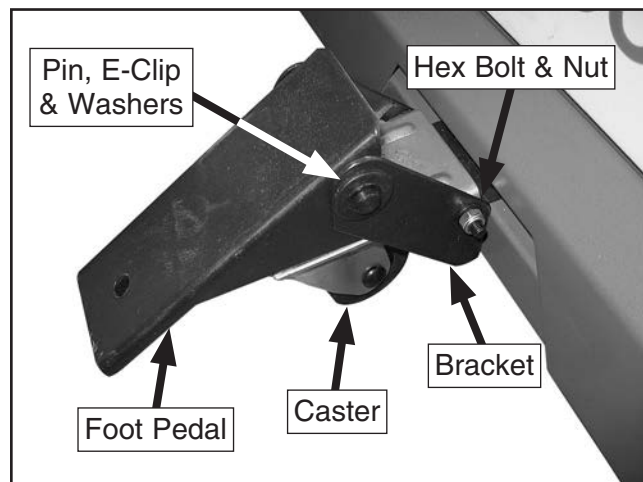

Figure 13. Foot pedal and caster installed.



Dust Collection

CAUTION

DO NOT operate the Model G0453/G0454 without an adequate dust collection system. This planer creates substantial amounts of wood dust while operating. Failure to use a dust collection system can result in short and long-term respiratory illness.

Recommended CFM at Dust Port

- G0453.....400 CFM
- G0454.....625 CFM

Do not confuse this CFM recommendation with the rating of the dust collector. To determine the CFM at the dust port, you must consider these variables: (1) CFM rating of the dust collector, (2) hose type and length between the dust collector and the machine, (3) number of branches or wyes, and (4) amount of other open lines throughout the system. Explaining how to calculate these variables is beyond the scope of this manual. Consult an expert or purchase a good dust collection "how-to" book.

Check Gearbox Oil

It is critical that you make sure there is oil in the gearbox before proceeding with the test run. Refer to the **Lubrication** instructions for the gearbox on **Page 32** for more details on which type of oil to use, how much to use, and where to put it.



Test Run

Once the assembly is complete, test run your machine to make sure it runs properly and is ready for regular operation. The test run consists of verifying the following: 1) The motor powers up and runs correctly and 2) the stop button safety feature works correctly.

If, during the test run, you cannot easily locate the source of an unusual noise or vibration, stop using the machine immediately, then review **Troubleshooting on Page 33**.

If you cannot find a remedy, contact our Tech Support at (570) 546-9663 for assistance.

WARNING

Before starting the planer, make sure you have performed the preceding assembly and adjustment instructions, and you have read through the rest of the manual and are familiar with the various functions and safety features on this machine. Failure to follow this warning could result in serious personal injury or even death!

To test run the machine:

1. Make sure you understand the safety instructions at the beginning of the manual and that the machine is set up properly.
2. Make sure all tools and objects used during set up are cleared away from the machine.
3. Make sure the gearbox has the correct amount of oil (refer to **Gearbox Oil on Page 32** for detailed instructions).



4. Push the OFF button in, then twist it clockwise so it pops out. When the OFF button pops out, the switch is reset and ready for operation (see **Figure 14**).

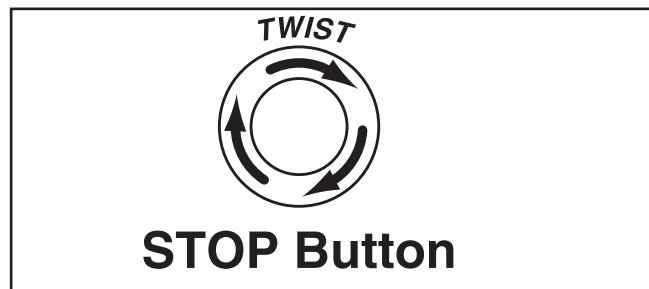

Figure 14. Resetting the switch.

5. Verify that the machine is operating correctly by pushing the ON button.

—When operating correctly, the machine runs smoothly with little or no vibration or rubbing noises.

—Investigate and correct strange or unusual noises or vibrations before operating the machine further. Always disconnect the machine from power when investigating or correcting potential problems.

6. Press the OFF button to stop the machine.

7. WITHOUT resetting the switch, press the ON button. The machine should not start.

—If the machine does not start, the OFF button safety feature is working correctly. The **Test Run** is complete.

—If the machine does start (with the OFF button pushed in), immediately disconnect power to the machine. The OFF button safety feature is not working correctly. This safety feature must work properly before proceeding with regular operations. Call Tech Support for help.

Re-Tension V-Belts

The final step of the setup process must be done after approximately 16 hours of operation. During this period, the V-belts will stretch and seat into the pulley grooves and need to be properly tensioned to avoid severely reducing the life of the V-belts. Refer to **V-Belts** on **Page 37** for detailed instructions.

Recommended Adjustments

For your convenience, the adjustments listed below have been performed at the factory.

However, because of the many variables involved with shipping, we recommend that you at least verify the following adjustments to ensure the best possible results from your new machine.

Step-by-step instructions for these adjustments can be found in the **SERVICE** section starting on **Page 33**.

Factory adjustments that should be verified:

- Table height chain tension (**Page 39**).
- Chip breaker height (**Page 40**).
- Pressure bar height (**Page 40**).
- Infeed/outfeed roller height (**Page 40**).
- Roller spring tension (**Page 43**).
- Chip deflector positioning (**Page 43**).



SECTION 4: OPERATIONS

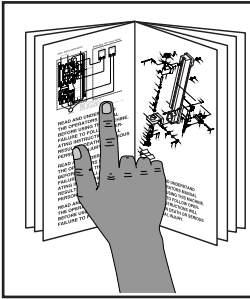

⚠️WARNING

To reduce the risk of serious injury when using this machine, read and understand this entire manual before beginning any operations.

⚠️WARNING

Damage to your eyes, lungs, and ears could result from using this machine without proper protective gear. Always wear safety glasses, a respirator, and hearing protection when operating this machine.

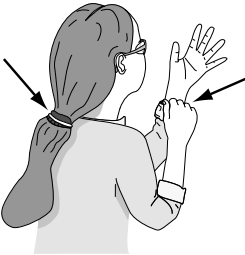
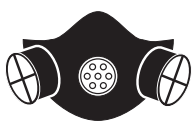

⚠️WARNING

Loose hair, clothing, or jewelry could get caught in machinery and cause serious personal injury. Keep these items away from moving parts at all times to reduce this risk.

NOTICE

If you have never used this type of machine or equipment before, WE STRONGLY RECOMMEND that you read books, review industry trade magazines, or get formal training before beginning any projects. Regardless of the content in this section, Grizzly Industrial will not be held liable for accidents caused by lack of training.

Operation Overview

The purpose of this overview is to provide the novice machine operator with a basic understanding of how the machine is used during operation, so the machine controls/components discussed later in this manual are easier to understand.

Due to the generic nature of this overview, it is **not** intended to be an instructional guide. To learn more about specific operations, read this entire manual, seek additional training from experienced machine operators, and do additional research outside of this manual by reading "how-to" books, trade magazines, or websites.

To complete a typical operation, the operator does the following:

1. Examines the workpiece to make sure it is acceptable for planing.
2. Puts on safety glasses or a face shield, a respirator, and ear protection.
3. If necessary, uses a jointer to make one surface of the workpiece flat.
4. Correctly adjusts the worktable height for the operation.
5. If the workpiece is longer than can be supported by the planer table, arranges for assistance or roller accessories to support the workpiece.
6. When all safety precautions have been taken, turns the planer **ON**, then sets the correct feed rate for the operation.
7. Stands to one side of the planer path to reduce the risk of kickback injuries, then, with the flat surface of the workpiece facing down, feeds the workpiece into the planer until the infeed roller grabs it.
8. Once the workpiece is clear of the outfeed roller, turns the planer **OFF**.



Planing Tips

- Use the full width of the planer. Alternate between the left, the right and the middle of the table when feeding lumber into the planer. Your knives will remain sharp much longer.
- Scrape all glue off of joined boards before planing. Dried glue is extremely hard on the knives.
- Plane ONLY natural wood fiber. Do not plane wood composites or other materials that could break up in the planer and cause operator injury or property damage.
- To avoid chipping, plane the workpiece with the grain. NEVER feed end-cut or end-grained lumber into your planer.
- Keep your work area clear to help ensure safe working conditions.
- Always true any cupped or warped stock on a jointer before planing and feed the workpiece into the planer with the flat face down. This will ensure the workpiece will not rock or twist as it goes through the planer.
- When possible, plane both faces of the workpiece so that they will be parallel with one another.

Workpiece Inspection

Some workpieces are not safe to use or may require modification before they are. **Before cutting, inspect all workpieces for the following:**

- **Material Type:** This machine is only intended for workpieces of natural wood fiber. Attempting to use workpieces of any other material that may break apart during operation could lead to serious personal injury and property damage.
- **Foreign Objects:** Inspect lumber for defects and foreign objects (nails, staples, imbedded gravel, etc.). If you have any question about the quality of your lumber, DO NOT use it. Remember, wood stacked on a concrete floor can have small pieces of stone or concrete pressed into the surface.
- **Large/Loose Knots:** Loose knots can become dislodged during operation. Large knots can cause kickback and machine damage. Always use workpieces that do not have large/loose knots.
- **Wet or "Green" Stock:** Avoid using wood with a high water content. Wood with more than 20% moisture content or wood exposed to excessive moisture (such as rain or snow), will cut poorly and cause excessive wear to the machine. Excess moisture can also hasten rust and corrosion of the machine and/or individual components.
- **Excessive Warping:** Workpieces with excessive cupping, bowing, or twisting are dangerous to cut because they are unstable and often unpredictable when being cut. DO NOT use workpieces with these characteristics!
- **Minor Cupping:** Workpieces with slight cupping can be safely supported if the cupped side is facing the table. On the contrary, a workpiece supported on the bowed side will rock during operation and could cause severe injury from kickback.



Wood Hardness

The species of wood, as well as its condition, greatly affects the depth of cut the planer can effectively take with each pass.

The chart in the figure below shows the Janka Hardness Rating for a number of commonly used species. The larger the number, the harder the workpiece, and the less material should be removed in any one pass for good results.

Note: *The Janka Hardness Rating is expressed in pounds of force required to embed a 0.444" steel ball into the surface of the wood to a depth equal to half the ball's diameter.*

Species	Janka Hardness
Ebony	3220
Red Mahogany	2697
Rosewood	1780
Red Pine	1630
Sugar Maple	1450
White Oak	1360
White Ash	1320
American Beech	1300
Red Oak	1290
Black Walnut	1010
Teak	1000
Black Cherry	950
Cedar	900
Sycamore	770
Douglas Fir	660
Chestnut	540
Hemlock	500
White Pin	420
Basswood	410
Eastern White Pine	380
Balsa	100

Figure 15. Janka Hardness Rating for some common wood species.

Feed Rate

The infeed and outfeed rollers move the workpiece through the planer while keeping it flat and providing a consistent rate of movement. The speed that these rollers move the workpiece through the planer is known as the feed rate.

Generally, low feed rates are used for dimensioning passes, while higher feed rates are used for finishing passes.

Figure 16 illustrates the three different positions of the feed rate control knob:

- Push the knob in to use the high feed rate (30 FPM for Model G0453, and 20 FPM for Model G0454).
- Pull the knob out to use the low feed rate of 16 FPM.
- Move the knob to the center position to place the gearbox in neutral.

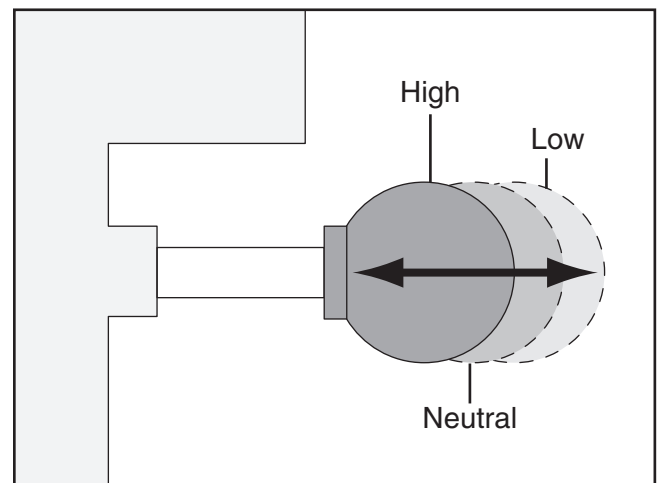

Figure 16. Feed rate control knob positions.

NOTICE

Only change the feed rate when the planer is running, but DO NOT attempt to change the feed rate during any cutting operations or damage to the gearbox will result.



Depth of Cut

The depth of cut on a planer means the amount of material that is removed from the top of the workpiece as it passes underneath the cutterhead.

The depth of cut is set by adjusting the distance of the table below the cutterhead. This distance is the thickness of the workpiece minus the depth of cut.

Although the correct depth of cut varies according to wood hardness and workpiece width, we recommend a maximum depth of cut no more than $\frac{1}{16}$ ". A series of light cuts will give better end results and put less stress on the planer than trying to take off too much material in a single pass.

The planing depth of cut is controlled by using the table height handwheel on the right side of the machine. Rotating the handwheel clockwise raises the table.

The depth of cut is read directly from the inch/millimeter scale on the front of the planer, as shown in **Figure 17**.

One complete turn of the handwheel raises or lowers the table approximately $\frac{1}{16}$ ". The range of material thickness that can be planed is $\frac{3}{16}$ "–8".

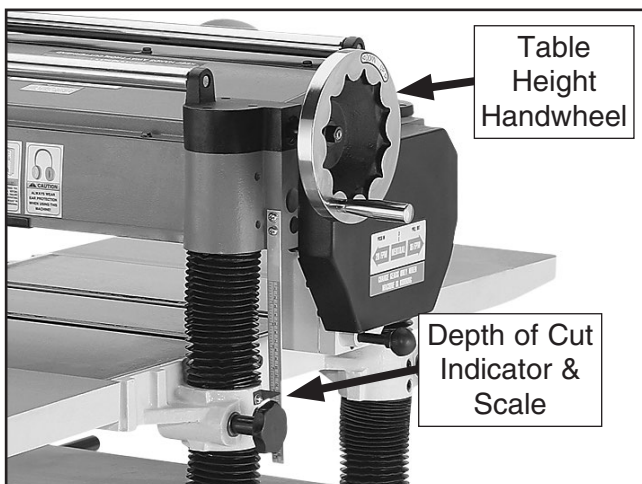

Figure 17. Depth of cut indicator and scale.

Bed Roller Height

Bed Roller Height Range0.002"–0.020"

The correct height of the bed rollers will vary, depending on the type of material you intend to plane. However, as a general rule, keep the bed roller height within 0.002"–0.020" above the table surface, as illustrated in **Figure 18**.

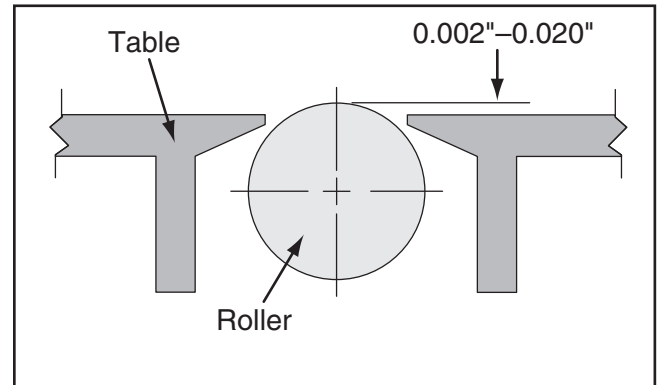

Figure 18. Recommended bed roller height above the table surface.

When planing rough stock, set the rollers high to keep the lumber from dragging along the bed. When planing milled lumber, set the rollers low to help minimize snipe.

To ensure accurate results and make the adjustment process quicker and easier, we recommend using a Rotacator (refer to **Page 28**) to gauge the bed roller height from the table surface. If a Rotacator is not available, a straightedge and feeler gauges can be used, but care must be taken to achieve accurate results.



NOTICE

Bed rollers that are not adjusted to the correct height or out of alignment with each other can cause poor finishes, inconsistent planing thickness, and other undesirable results.

Tools Needed	Qty
Hex Wrench 3mm.....	1
Wrench 14mm	1
Rotacator	1

To adjust the bed rollers:

1. DISCONNECT PLANER FROM POWER!
2. Lower the table all the way to give yourself room to work.
3. Loosen the set screws above each of the four roller adjustment hex bolts (see **Figure 19**).

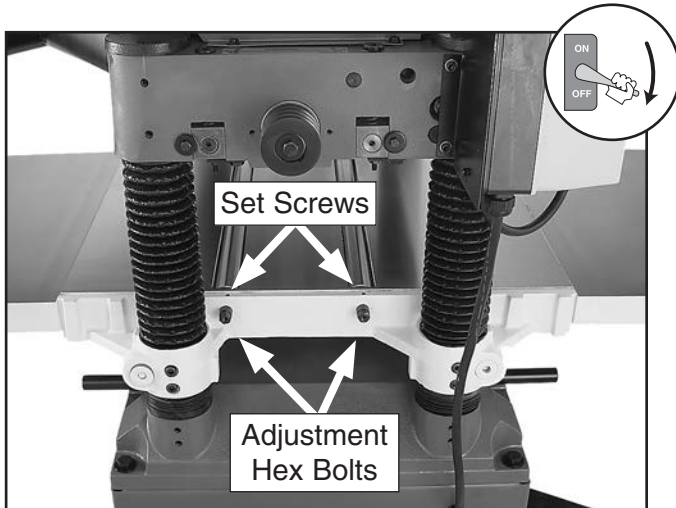

Figure 19. Bed roller height controls.

4. Rotate the eccentric adjustment hex bolts to raise or lower the bed rollers until they are the desired height above the table surface.
5. Verify that both sides of each roller are at the same height, then re-tighten the four set screws to secure the setting.
6. Re-check the roller heights to make sure they did not change when you secured them.

—If the roller heights are not correct, repeat this procedure until they are.



SECTION 5: ACCESSORIES

⚠️ WARNING

Some aftermarket accessories can be installed on this machine that could cause it to function improperly, increasing the risk of serious personal injury. To minimize this risk, only install accessories recommended for this machine by Grizzly.

NOTICE

Refer to the newest copy of the Grizzly Catalog for other accessories available for this machine.

Call 1-800-523-4777 To Order

G1738—Rotacator™ Precision Planer Tool

The Rotacator is a dial indicator on a magnetic base and is designed for quickly and accurately setting the critical tolerances needed when adjusting any planer, so that nasty surprises such as non-parallel and chattered cuts can be eliminated. Helps adjust infeed/outfeed rollers, pressure bars, chip breakers, and bed rollers. Also a great setup tool for other machines! Accurate to 0.001". Indicator rotates 360°

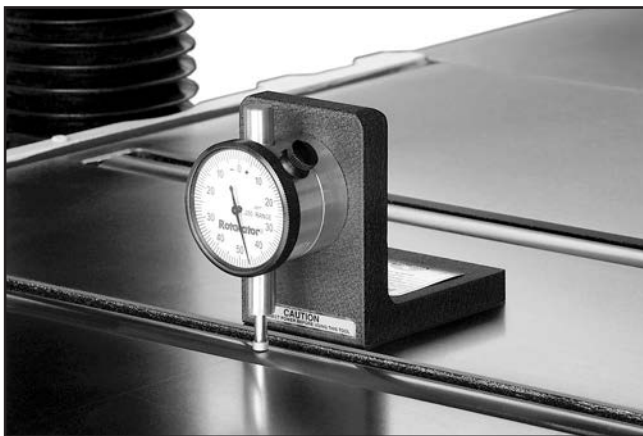

Figure 20. Rotacator™ Precision Planer Tool.

include dust collector

G6701—HSS Replacement Knives for Model G0453, Set of 3

G6702—HSS Replacement Knives for Model G0454, Set of 4

G2790—Universal Knife Grinder

This dry-type Knife Grinder is ideal for sharpening planer and jointer knives. High quality cast iron construction, together with large knife holding capacity (will sharpen up to 20" planer/jointer knives) makes this grinder an excellent investment. Features a heavy-duty ½ HP 110V motor, knife holding angle adjustable from 20° to 70°, and adjustable-height 120 grit grinding wheel.

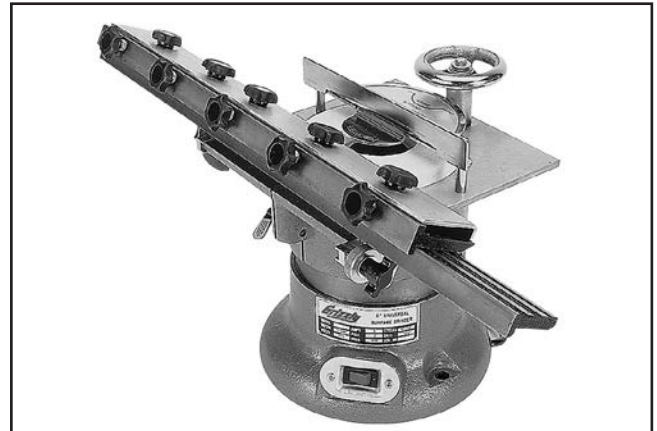

Figure 21. G2790 Universal Knife Grinder.

H7768—15" Byrd® Shelix Cutterhead

H7768—20" Byrd® Shelix Cutterhead

Made in the USA by Byrd, this indexable carbide insert cutterhead is the best money can buy—period! The inserts are not only placed in a spiral pattern, they are also positioned at an angle so the shearing action leaves a glassy smooth cut on the toughest and most figured woods. Comes with 5 extra replacement inserts. Great upgrade!

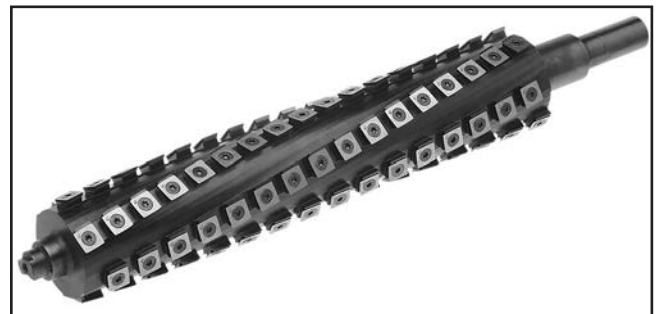

Figure 22. Byrd® Shelix Cutterhead.



- T20501—Face Shield Crown Protector 4"
- T20502—Face Shield Crown Protector 7"
- T20503—Face Shield Window
- T20448—Economy Clear Safety Glasses
- T20452—"Kirova" Anti-Reflective Glasses
- T20456—"Dakura" Clear Safety Glasses
- H0736—Shop Fox® Safety Glasses

These glasses meet ANSI Z87.1-2003 specifications. Buy extras for visitors or employees. You can't be too careful with shop safety!

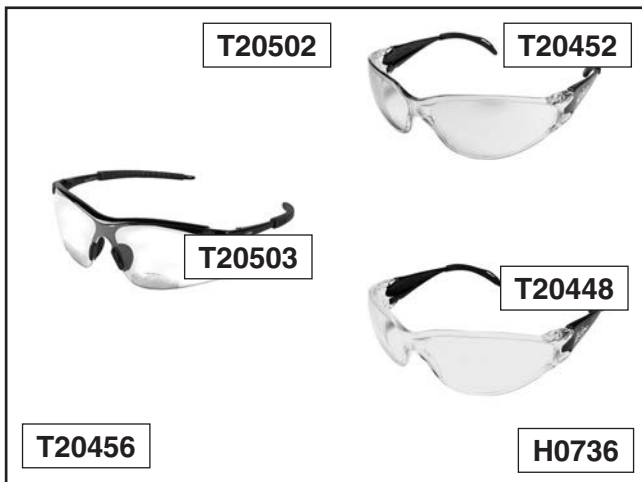

Figure 23. Our most popular eye protection.

G8982—Roller Table

Use this versatile roller table wherever you need extra workpiece support. Features all steel welded construction and measures 19" x 65" long. Comes with 9 ball bearing rollers and has four independently adjustable legs for any leveling requirement. Adjustable in height from 26³/₈" to 44¹/₈".



Figure 24. SHOP FOX® Roller Table.

- H9155—Dispoz-A-Blade® System 15" (Includes 3 Holders & Knife Inserts)
- G5858—Dispoz-A-Blade® Knife Inserts 15" HSS (Set of 3)
- H9156—Dispoz-A-Blade® System 20" (includes 4 Holders & Knife Inserts)
- G5859—Dispoz-A-Blade® Knife Inserts 20" HSS (Set of 4)

Install a Dispoz-A-Blade® Knife system in your new planer and save up to 70% on knife replacements for the life of your machine. Each knife insert is double-edged, so you get two knives in one, and is indexed so that all knife inserts can be installed at the same height in just minutes. Yes, that means you can throw away the knife gauge!

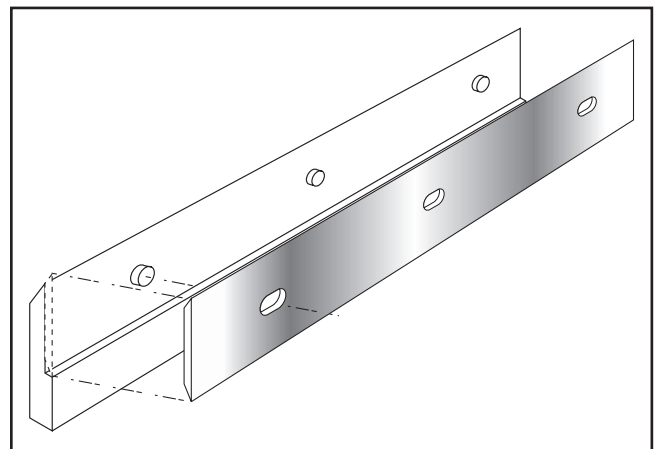

Figure 25. Dispoz-A-Blade® Holder and Knife.

- G5562—SLIPIT® 1 Qt. Gel
- G5563—SLIPIT® 12 oz Spray
- G2871—Boeshield® T-9 12 oz Spray
- G2870—Boeshield® T-9 4 oz Spray
- H3788—G96® Gun Treatment 12 oz Spray
- H3789—G96® Gun Treatment 4.5 oz Spray



Figure 26. Recommended products for protecting unpainted cast iron/steel part on machinery.



SECTION 6: MAINTENANCE

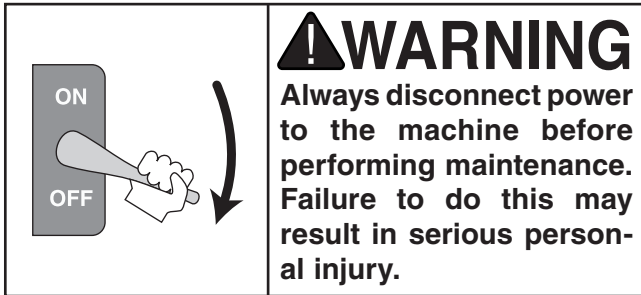

Schedule

For optimum performance from your machine, follow this maintenance schedule and refer to any specific instructions given in this section.

Note: *This maintenance schedule is based on average daily usage. Adjust the maintenance schedule to match your usage to keep your planer running smoothly and to protect your investment.*

Every 8 Hours of Operation:

- Clean machine and protect unpainted cast iron.
- Lubricate feed rollers bushings (**Page 31**).
- Tighten loose mounting bolts.
- Check/sharpen/replace damaged or worn knives (**Page 36**).
- Check/repair/replace worn or damaged wires.
- Resolve any other unsafe condition.

Every 40 Hours of Operation:

- Clean cutterhead and check knife height (**Page 36**).
- Lubricate table columns and leadscrews (**Page 31**).

Every 160 Hours of Operation:

- Check/tension/replace V-belts (**Page 37**).
- Clean/vacuum dust buildup from inside cabinet and off motor.
- Lubricate table height worm gear (**Page 31**).
- Lubricate table height chain and sprockets (**Page 32**).
- Lubricate drive chain and sprockets (**Page 32**).

Yearly:

- Change gearbox oil (**Page 32**).

Cleaning & Protecting

Vacuum excess wood chips and sawdust from the outside of the machine, inside the cabinet, and off the motor. Protect the unpainted cast iron surfaces on the table by wiping the table clean after every use—this ensures moisture from wood dust does not remain on bare metal surfaces.

Keep tables rust-free with regular applications of products like G96® Gun Treatment, SLIPIT®, or Boeshield® T-9 (see **Section 5: Accessories** on **Page 29** for more details).



Lubrication

NOTICE

Failure to followed reasonable lubrication practices as instructed in this manual for your machine could lead to premature failure of components and void the warranty.

Your planer features bearings that are lubricated and sealed at the factory. These bearing do not require any further attention unless they need to be replaced. If a bearing fails, your planer will probably develop a noticeable rumble or vibration, which will increase when the machine is under a load. The bearings are standard sizes and can be replaced through Grizzly (refer to the **Parts Breakdowns** beginning on **Page 49** for bearing identification).

Follow the maintenance schedule on **Page 30** and the procedures listed below to properly lubricate the other planer components, which are essential for long life and trouble-free operation of your planer.

Feed Roller Bushings

The infeed and outfeed rollers rotate inside bushing blocks on both ends of the rollers. Add 2–3 drops of SAE 30W oil to the center hole of the four feed roller tension adjustment bolts on top of the head casting, as shown in **Figure 27**.

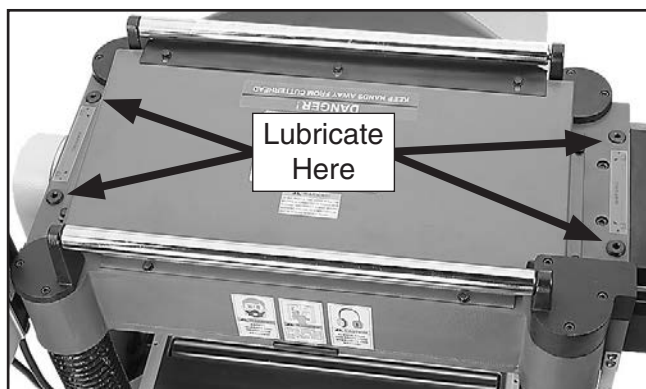

Figure 27. Lubrication locations for the feed roller bushings.

Columns and Leadscrews

The table rides on the columns and is moved by the rotation of the leadscrews inside the columns. For Model G0454, loosen the dust sleeve (see **Figure 28**) to access the columns and leadscrews. Apply a thin coat of SAE 30W oil to the outside surface of the columns and brush on a light application of multi-purpose grease to the leadscrew threads. Move the table up and down to distribute the lubricant.

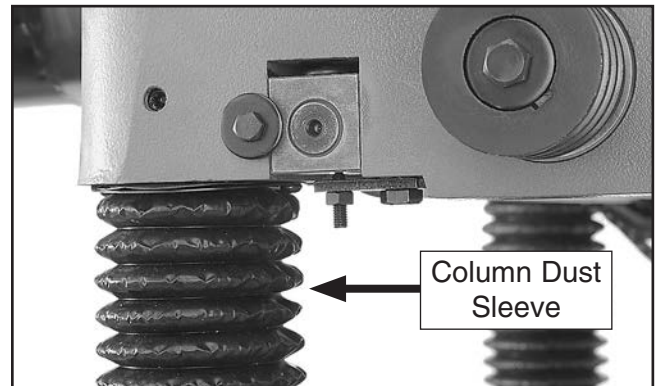

Figure 28. Model G0454 column dust sleeve.

Table Height Worm Gear

Remove the three cap screws that secure the worm gear housing (see **Figure 29**), then lift the housing and handwheel assembly off the machine. Clean away any debris from the housing and gears, then brush on a moderate amount of multi-purpose grease to the gear teeth.

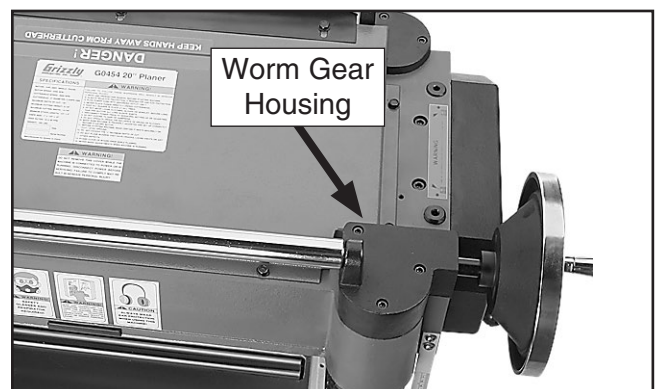

Figure 29. Location of the table height worm gear housing.



Table Height Chain & Sprockets

The table leadscrews are synchronized by the table height chain and sprockets located underneath the base of the planer. Remove the front and rear cabinet panels to access these parts (see **Figure 30**). Use shop rags and mineral spirits to clean away debris and grime, then brush on a light coat of multi-purpose grease to the chain and sprockets.

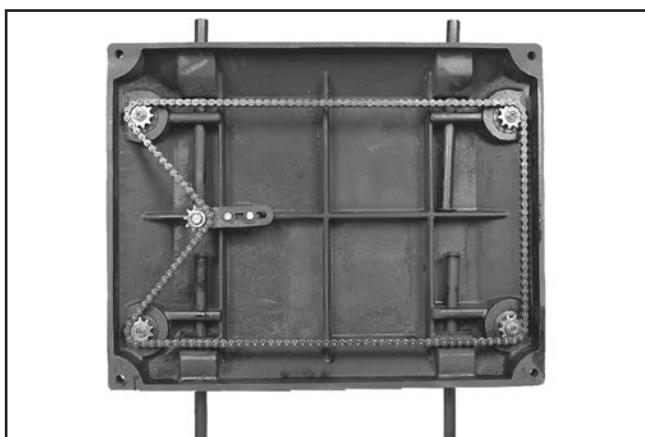

Figure 30. Table height chain and sprockets as viewed from underneath the base.

Drive Chain & Sprockets

The infeed and outfeed rollers receive the transferred power from the cutterhead through the drive chain system on the right side of the machine, as shown in **Figure 31**.

Remove the table height handwheel and the safety covers attached to the inside of the drive chain cover, then remove the cover to access these parts.

Use shop rags and mineral spirits to clean away any debris and grime, then brush on a light coat of multi-purpose grease to the chain and sprockets.

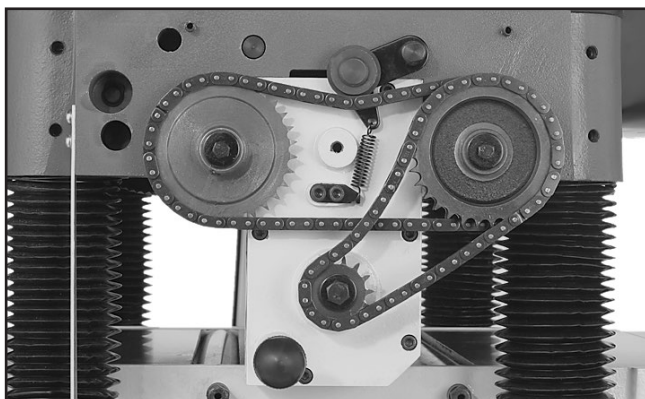

Figure 31. Drive chain and sprockets.

Gearbox Oil

The gearbox oil should be changed after the first 20 hours of operation to clear away any debris inside the gearbox, then changed annually thereafter.

Although it is not necessary to remove the drive chain cover to access the fill and drain plugs, it is more convenient to do so (see **Figures 32–33**). Replace the gearbox oil with 80W–90W gear oil until it just reaches the fill plug.

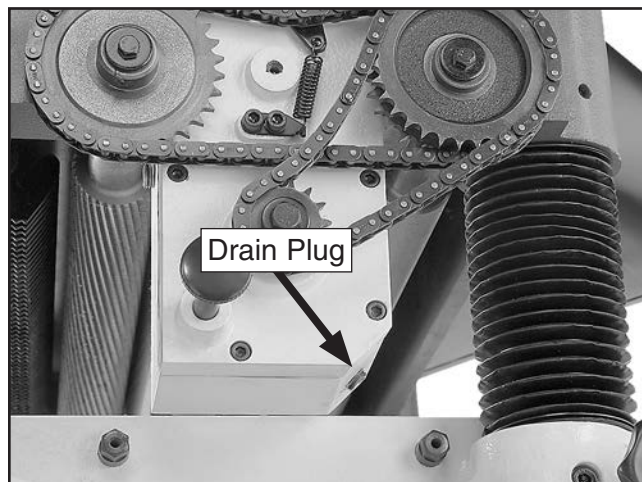

Figure 32. Gearbox drain plug.

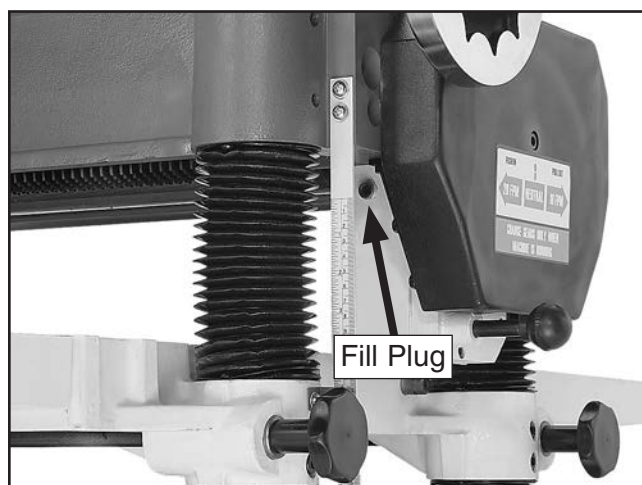

Figure 33. Gearbox fill plug.



SECTION 7: SERVICE

Review the troubleshooting procedures in this section if a problem develops with your machine. If you need replacement parts or additional help with a procedure, call our Technical Support. **Note:** *Please gather the serial number and manufacture date of your machine before calling.*

Troubleshooting

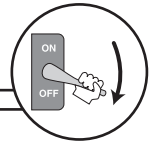

Motor & Electrical

Symptom	Possible Cause	Possible Solution
Machine does not start or a breaker trips.	<ol style="list-style-type: none"> 1. Stop push-button engaged/faulty. 2. Power supply switched OFF or at fault. 3. Thermal overload relay has tripped. 4. Wall circuit breaker tripped. 5. Plug/receptacle at fault/wired wrong. 6. Motor connection wired wrong. 7. Contactor not energized/has poor contacts. 8. Wiring open/has high resistance. 9. ON/OFF switch at fault. 10. Start capacitor at fault. 11. Centrifugal switch at fault. 12. Motor at fault. 	<ol style="list-style-type: none"> 1. Rotate button to reset/replace it. 2. Ensure power supply is on/has correct voltage. 3. Reset; adjust trip load dial if necessary; replace. 4. Ensure circuit size is correct/replace weak breaker. 5. Test for good contacts; correct the wiring. 6. Correct motor wiring connections (Pages 47–48). 7. Test all legs for power/replace if faulty. 8. Check/fix broken, disconnected, or corroded wires. 9. Replace switch. 10. Test/replace if faulty. 11. Adjust/replace centrifugal switch. 12. Test/repair/replace.
Machine stalls or is underpowered.	<ol style="list-style-type: none"> 1. Feed rate too fast. 2. Workpiece material not suitable. 3. Dust collection ducting problem. 4. Motor overheated. 5. Machine undersized for task. 6. V-belt(s) slipping. 7. Motor wired incorrectly. 8. Plug/receptacle at fault. 9. Run capacitor at fault. 10. Pulley/sprocket slipping on shaft. 11. Motor bearings at fault. 12. Contactor not energized/has poor contacts. 13. Motor at fault. 14. Centrifugal switch at fault. 	<ol style="list-style-type: none"> 1. Decrease feed rate. 2. Only cut wood/ensure moisture is below 20%. 3. Clear blockages, seal leaks, use smooth wall duct, eliminate bends, close other branches. 4. Clean motor, let cool, and reduce workload. 5. Use sharp blades/inserts; reduce feed rate or depth of cut. 6. Tension/replace belt(s) (Page 37); ensure pulleys are aligned (Page 45). 7. Wire motor correctly (Pages 47–48). 8. Test for good contacts/correct wiring. 9. Test/repair/replace. 10. Replace loose pulley/shaft. 11. Test/repair/replace. 12. Test all legs for power/replace if faulty. 13. Test/repair/replace. 14. Adjust/replace centrifugal switch.
Machine has vibration or noisy operation.	<ol style="list-style-type: none"> 1. Belts slapping cover. 2. Knives/gibs at fault. 3. Blade at fault. 4. V-belt(s) worn or loose. 5. Pulley loose. 6. Motor mount loose/broken. 7. Machine incorrectly mounted. 	<ol style="list-style-type: none"> 1. Replace/realign belts with a matched set. 2. Resharpen/replace knives; set knife alignment/height correctly. 3. Replace warped/bent blade; resharpen dull blade. 4. Inspect/replace belts with a new matched set. 5. Realign/replace shaft, pulley, setscrew, and key. 6. Tighten/replace. 7. Tighten mounting bolts; relocate/shim machine.



Motor & Electrical (continued)

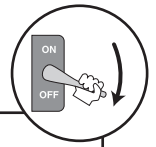

Symptom	Possible Cause	Possible Solution
Machine has vibration or noisy operation.	<ul style="list-style-type: none"> 8. Motor fan rubbing on fan cover. 9. Bed rollers protruding unevenly. 10. Motor bearings at fault. 11. Cutterhead bearings at fault. 12. Centrifugal switch is at fault. 13. Chip deflector hitting knives. 	<ul style="list-style-type: none"> 8. Fix/replace fan cover; replace loose/damaged fan. 9. Adjust bed rollers (Page 26). 10. Test by rotating shaft; rotational grinding/loose shaft requires bearing replacement. 11. Replace bearing(s)/realign cutterhead. 12. Replace switch. 13. Check/replace chip deflector and realign (Page 43).

Machine Operation

Symptom	Possible Cause	Possible Solution
<p>Excessive snipe (gouge at the end of the workpiece that is uneven with the rest of the cut).</p> <p>Note: <i>A small amount of snipe is inevitable with all types of planers—the key is to minimize it.</i></p>	<ul style="list-style-type: none"> 1. One or both of the bed rollers are set too high. 2. Rear extension wing slopes down or is not level with main table. 3. Chip breaker or pressure bar set too low. 4. Workpiece is not properly supported as it leaves the planer. 	<ul style="list-style-type: none"> 1. Lower the bed rollers (Page 26). 2. Adjust the rear extension wing set screws to make the extension level with the main table (Page 18). 3. Raise the height of the chip breaker or pressure bar (Page 40). 4. Use an assistant or roller beds/stands to properly support the workpiece as it leaves the planer.
Workpiece stops/slow in the middle of the cut.	<ul style="list-style-type: none"> 1. Depth of cut too deep. 2. Pitch and glue build-up on planer components. 3. One or both of the bed rollers are set too low or too high. 4. Chip breaker or pressure bar set too low. 5. Feed rollers set too low or too high. 	<ul style="list-style-type: none"> 1. Reduce the depth of cut (Page 26). 2. Clean planer components with a pitch/resin dissolving solvent. 3. Lower/raise the bed rollers (Page 26). 4. Raise the height of the chip breaker or pressure bar (Page 40). 5. Adjust the feed rollers to the correct height (Page 40).
Consistent chipping pattern.	<ul style="list-style-type: none"> 1. Knots or conflicting grain direction in workpiece. 2. Nicked or chipped knife. 3. Feed rate too fast. 4. Depth of cut too deep. 5. Misaligned chip breaker. 	<ul style="list-style-type: none"> 1. Inspect workpiece for knots and grain direction; use only clean stock (Page 24). 2. Sharpen/replace knife (Page 36). 3. Reduce feed rate (Page 25). 4. Reduce the depth of cut (Page 26). 5. Adjust both sides of chip breaker to the correct height (Page 40).



Machine Operation (continued)

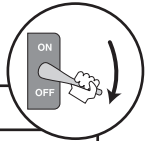

Symptom	Possible Cause	Possible Solution
Fuzzy grain.	<ol style="list-style-type: none"> 1. Workpiece has high moisture content or surface wetness. 2. Dull knives/inserts. 	<ol style="list-style-type: none"> 1. Sticker and allow workpiece to dry if moisture content is over 20% or has surface wetness. 2. Sharpen/replace knives (Page 36).
Long lines or ridges that run the length of the workpiece.	<ol style="list-style-type: none"> 1. Nicked or chipped knife. 	<ol style="list-style-type: none"> 1. Sharpen/replace knives (Page 36).
Uneven cutting marks, wavy surface, or chatter marks across the face of the workpiece.	<ol style="list-style-type: none"> 1. Feed rate too fast. 2. Chip breaker or pressure bar set unevenly. 3. One or both of the bed rollers are set too low or too high. 4. Knife heights not correct. 5. Worn cutterhead bearings. 	<ol style="list-style-type: none"> 1. Reduce feed rate (Page 25). 2. Adjust the height of the chip breaker or pressure bar (Page 40). 3. Lower/raise the bed rollers (Page 26). 4. Adjust knives to the proper height (Page 36). 5. Replace cutterhead bearings.
Glossy surface.	<ol style="list-style-type: none"> 1. Knives are dull. 2. Feed rate too slow. 3. Depth of cut too shallow. 	<ol style="list-style-type: none"> 1. Sharpen/replace knives (Page 36). 2. Increase feed rate (Page 25). 3. Increase depth of cut (Page 26).
Inconsistent chip marks.	<ol style="list-style-type: none"> 1. Chips are not being properly expelled from around the cutterhead. 	<ol style="list-style-type: none"> 1. Use an adequate dust collection system; adjust the chip deflector in or out, depending upon your setup (Page 43).



Setting/Replacing Knives

⚠ CAUTION

Planer knives are extremely sharp and can quickly cause a serious injury to your hands or fingers. Always wear heavy leather gloves when handling these knives to reduce the risk of cutting injuries.

Setting the height of the knives correctly is crucial to the proper operation of your planer and is very important in keeping the knives sharp. If one knife protrudes higher than the others, it will do the majority of the work, dull much faster, and produce poor cutting results.

The knife gauge that is included with the Model G0453/G0454 is designed to set the knives 0.059" higher than the cutterhead surface.

Note: If you need to replace or sharpen a knife, you can remove the knife from the cutterhead during **Step 4** of the following procedure. Thoroughly clean out any debris from the knife slots before replacing the knives.

Replacement knives are available through Grizzly (refer to **Page 28** for options).

Tools Needed	Qty
Hex Wrench 2.5mm (G0453).....	1
Wrench 10mm (G0453)	1
Hex Wrench 3mm (G0454).....	1
Wrench 12mm (G0454)	1
Knife Gauge	1

To adjust the height of the knives:

1. DISCONNECT PLANER FROM POWER!
2. Remove the dust hood and the top cover to expose the cutterhead.
3. Remove the belt cover, then rotate the cutterhead pulley to give you good access to one of the knives.

Note for G0454 Only: The cutterhead for the Model G0454 ships with both springs and jack screws to adjust the knife height (see **Figure 34**)—which one you use is up to your personal preference. However, you should remove the components that you will not use from the cutterhead before proceeding.

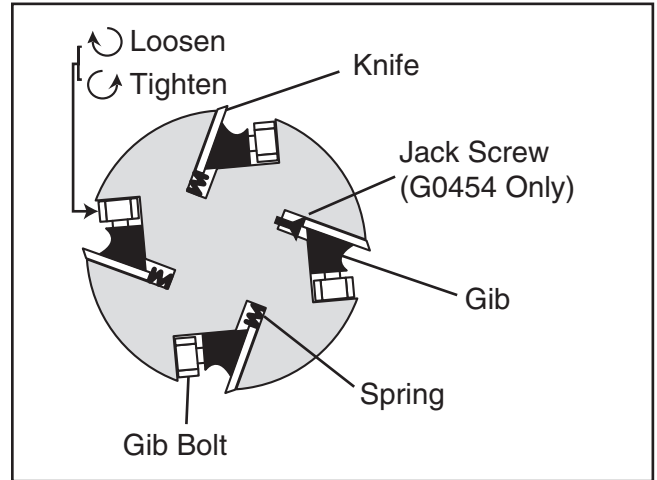

Figure 34. Cutterhead components (G0454 cutterhead shown).

4. If you have not already done so, loosen the cutterhead gib bolts until the knife is completely loose, then position the knife gauge over the knife so that the knife edge is directly under the center pad, as shown in **Figure 35**.

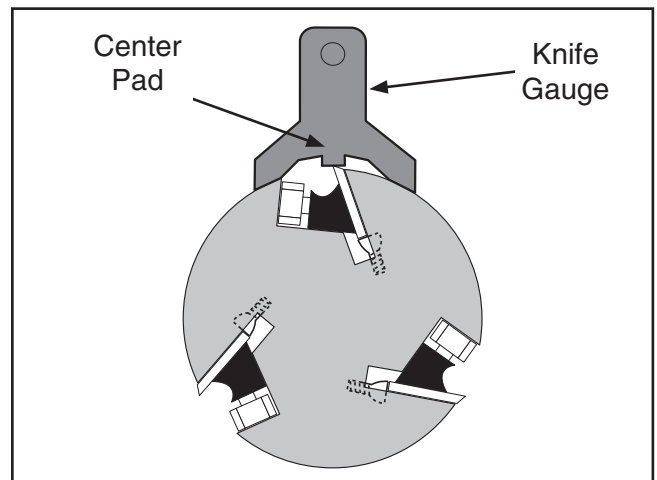

Figure 35. Knife gauge correctly positioned over the knife (G0453 cutterhead shown).



V-Belt Tensioning/ Replacement

- Jack Screws (G0453 & G0454):** Insert the hex wrench into the jack screws through the access holes in the cutterhead (see **Figure 36**). Rotate the jack screws to raise or lower the knife until it barely touches the center pad of the knife gauge with all legs of the gauge still firmly on the cutterhead, then snug the gib bolts enough to hold the knife in place.



Figure 36. Jack screw access hole in the cutterhead.

Springs (G0454 Only): Push down on the knife gauge until all legs of the gauge are firmly on the cutterhead and the knife just touches the center pad of the gauge, then tighten the gib bolts enough to hold the knife in place.

- Slightly tighten the gib bolts, starting at the middle and working your way to the ends by alternating left and right, as illustrated in **Figure 37**.

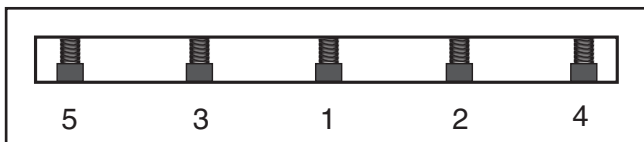

Figure 37. Gib bolt tightening sequence.

- Repeat **Step 6**.
- Repeat **Step 6**, but final tighten the gib bolts.
- Repeat **Steps 4–8** for the rest of the knives.

NOTICE

After the first 16 hours of use, the V-belts will stretch and seat into the pulley grooves. The V-belts must be properly re-tensioned after this period to avoid severely reducing their useful life.

Three cogged V-belts transfer power from the motor to the cutterhead, and then to the infeed and outfeed rollers with the use of the drive chain system. To ensure efficient transfer of power to these systems, make sure the V-belts are always properly tensioned and in good condition.

If the V-belts are worn, cracked, or damaged, replace them. Always replace the V-belts with a matched set of three, or belt tension may not be even among the belts, causing premature belt failure.

Tools Needed	Qty
Phillips Screwdriver	1
Wrench 19mm	1

To tension/replace the V-belts:

- DISCONNECT PLANER FROM POWER!

CAUTION

V-belts and pulleys will be hot after operation. Allow them to cool before handling them.



2. Remove the V-belt cover from the left side of the machine to expose the belts, as shown in **Figure 38**.

Note: A collection of black belt dust at the bottom of the belt cover is normal during the life of the belts.

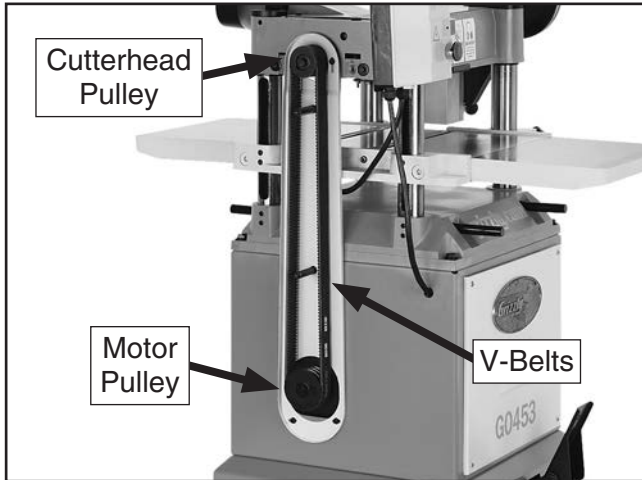

Figure 38. Belt cover removed to expose the V-belts and pulleys.

3. Remove the front cabinet panel to access the motor, as shown in **Figure 39**.

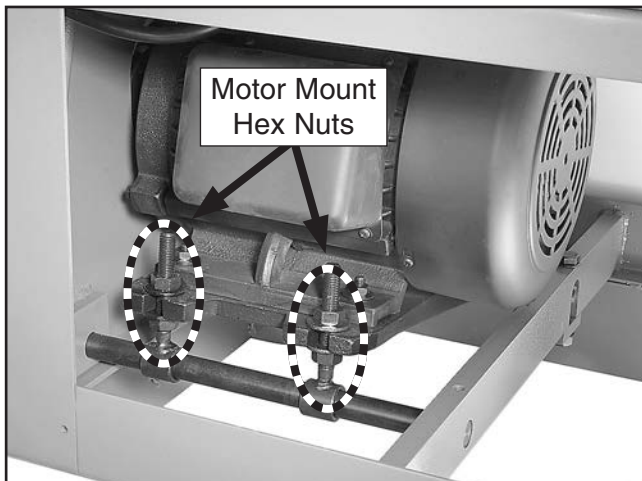

Figure 39. Front cabinet cover removed to expose the motor.

4. If the V-belts need to be replaced, raise the motor to release the belt tension (refer to the next step for instructions), roll them off the pulleys, then replace them as a matched set of 3.
5. To adjust the V-belt tension, loosen the top motor mount hex nuts (see **Figure 39**), then adjust the bottom hex nuts to raise or lower the motor.

Note: The V-belts are correctly tensioned when there is approximately $\frac{3}{4}$ " deflection when moderate pressure is applied to them midway between the pulleys, as illustrated in **Figure 40**.

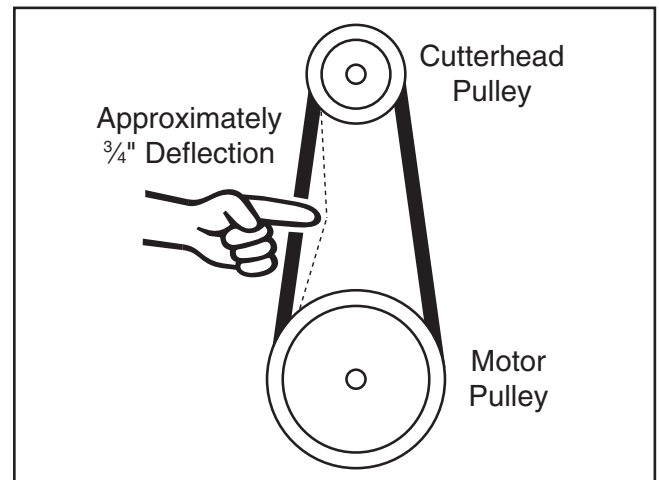

Figure 40. Belt deflection when V-belts are correctly tensioned.

6. When the V-belts are correctly tensioned, make sure the motor mount hex nuts are tight, then replace the cabinet cover and the belt cover.



Table Height Chain Tension

The table height chain transfers movement from the elevation handwheel to the columns that control table height. The chain drive can be adjusted to remove slack if the chain stretches over time or is loosened during table leveling procedures.

Tools Needed	Qty
Phillips Screwdriver #2	1
Wrench or Socket 12mm	1

To adjust the table height chain tension:

1. DISCONNECT PLANER FROM POWER!
2. Remove the front and rear cabinet panels to gain access to the chain system, as shown in **Figure 41**.

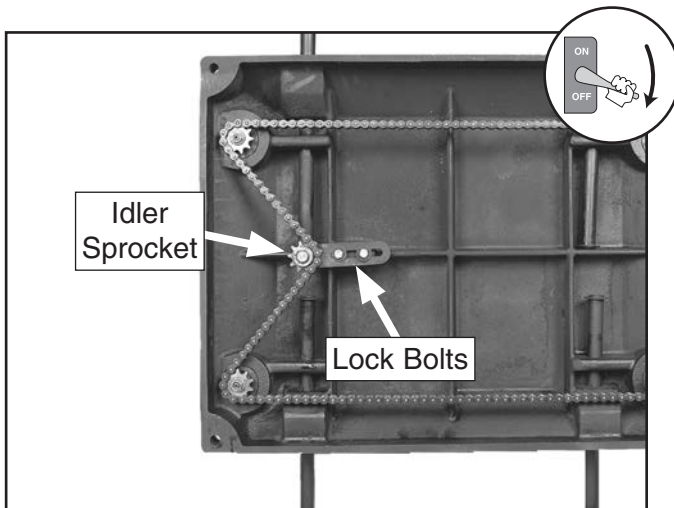

Figure 41. Table height idler sprocket and lock bolts (viewed from underneath the planer base).

NOTICE

During the next step, **DO NOT** let the chain fall off the sprockets. It can be very difficult to return the chain to its proper location on the sprockets without changing the table adjustments.

3. Loosen the lock bolts shown in **Figure 41**, and push the idler sprocket against the chain with moderate hand pressure, then while maintaining the pressure on the idler sprocket, re-tighten both lock bolts.
4. Clean and lubricate the chain and sprockets (refer to **Table Height Chain & Sprockets** on **Page 32** for detailed instructions).



Feed Rollers, Chip Breaker & Pressure Bar Heights

It is essential that the feed rollers, chip breaker, and pressure bar are set at the correct distance below the cutterhead to ensure that the workpiece moves through the planer evenly and the correct distance from the cutterhead knives.

To ensure accurate results and make the adjustment process quicker and easier, we recommend using a Rotacator for these adjustments (refer to **Page 28**).

If a Rotacator is not available, a 6' 2x4 cut into two even sized pieces and a feeler gauge set can be used, but care must be taken when jointing the wood to achieve accurate results.

Dist. Below Knife Edge at BDC (Figure 42)

A.	Infeed Roller	0.040"
B.	Chip Breaker.....	0.040"
C.	Pressure Bar.....	0.008"
D.	Outfeed Roller	0.020"

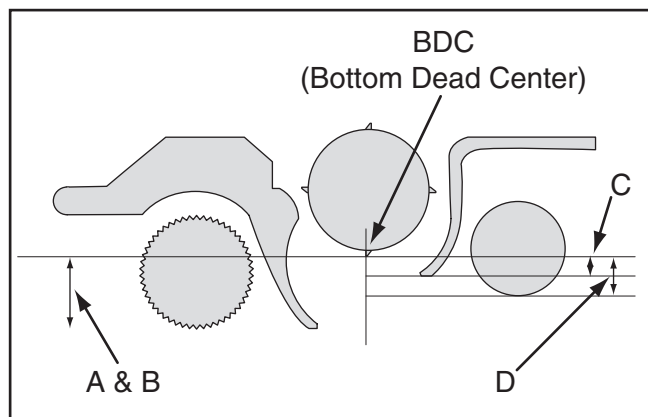

Figure 42. Planer component recommended clearances (illustration is not to scale).

Using a Rotacator

Tools Needed	Qty
Hex Wrenches 3, 5mm.....	1 Each
Wrench or Socket 10mm.....	1
Rotacator (see Page 28).....	1

1. DISCONNECT PLANER FROM POWER!
2. Make sure the knives are set to the correct height (refer to **Setting/Replacing Knives** on **Page 36** for detailed instructions).
3. Lower the table at least 4" below the head casting, then lock it in place.
4. Remove the dust hood, top cover, and belt cover.
5. Using your Rotacator, find the BDC of any knife edge by slowly rocking the cutterhead pulley back and forth, then set the Rotacator dial to zero (see **Figure 43**).

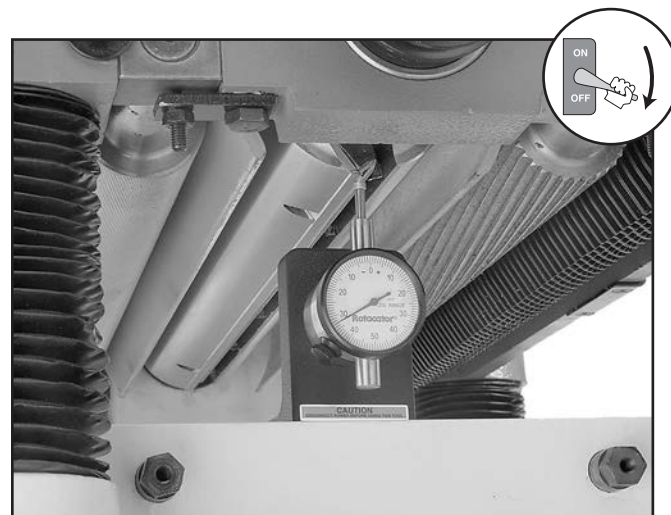

Figure 43. Using a Rotacator to find BDC.



6. Move the feed speed knob to the neutral position to allow the infeed roller to freely rotate.
7. Keeping the Rotacator dial at zero, position it under the right-hand side of the infeed roller and find the BDC of a serrated edge by rocking the infeed roller back and forth.
8. Loosen the jam nut and use the set screw shown in **Figure 44** to adjust the height of the infeed roller bushing block until the Rotacator dial shows 0.040", which is the recommended distance for the infeed roller below the cutterhead.

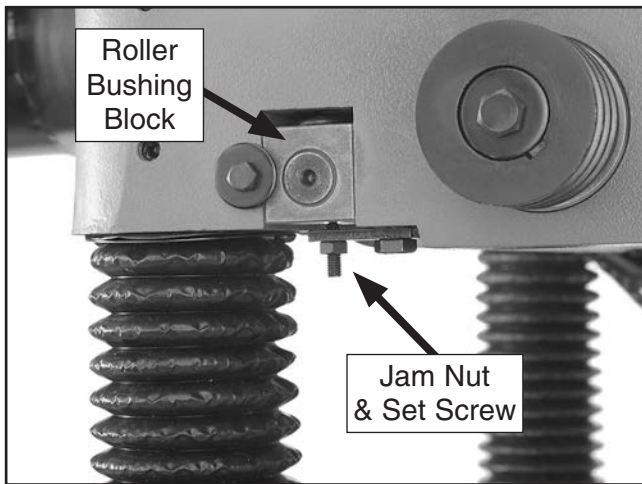

Figure 44. Infeed roller bushing block and height adjustment controls.

9. Repeat **Steps 7–8** on the left-hand side of the infeed roller.
10. Re-check both sides of the infeed roller and, if necessary, make further adjustments until the infeed roller height from side-to-side is 0.040" below the BDC of the cutterhead knife, then re-tighten both jam nuts.
11. Keeping the same zero reference on the Rotacator dial from **Step 5**, repeat **Steps 7–10** for the outfeed roller, but adjust it until it is 0.020" below the BDC of the cutterhead knife.

12. Use the same zero reference on the Rotacator dial from **Step 5**, perform similar steps as described above to adjust the height of the chip breaker to its recommended specification given at the beginning of this subsection. The adjustment controls are shown in **Figure 45**.

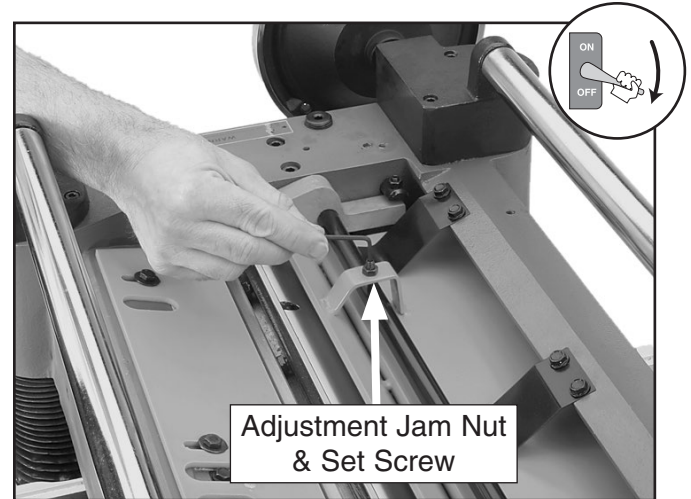

Figure 45. Adjusting the chip breaker height.

13. **Model G0454 Only:** Repeat **Step 12** for the pressure bar height adjustment. The adjustment controls are shown in **Figure 46**.



Figure 46. Adjusting the pressure bar height.

14. Re-install the belt cover, top cover, and the dust hood.



Using Wood Blocks

Tools Needed

	Qty
Hex Wrenches 3, 5mm.....	1 Each
Wrench or Socket 10mm.....	1
2x4 6' Long.....	1
Feeler Gauge Set.....	1

1. Build the wood blocks by cutting a *straight* 6' foot long 2x4 in half.

Note: *Having the wood blocks at an even height is critical to the accuracy of your overall adjustments. For best results, make the 2x4 square with a jointer and table saw before cutting it in half.*

2. Make sure the knives are set to the correct height (refer to **Setting/Replacing Knives** on **Page 36** for detailed instructions).
3. DISCONNECT PLANER FROM POWER!
4. Lower the bed rollers below the table surface (refer to **Bed Roller Height** on **Page 26** for detailed instructions).
5. Place the wood blocks along the sides of the table, as illustrated in **Figure 47**.

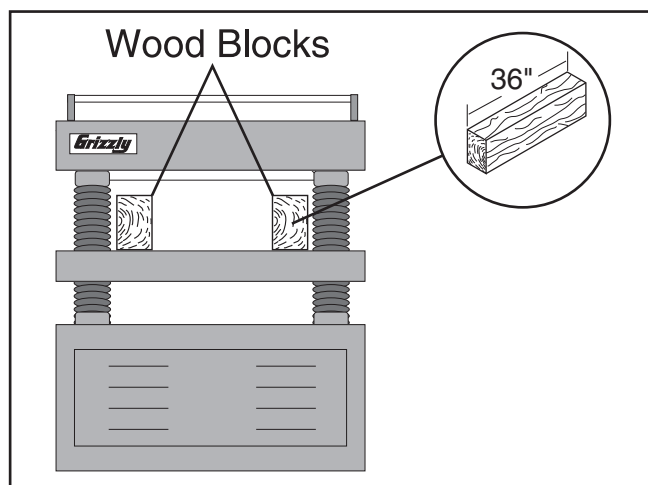

Figure 47. Wood blocks properly positioned on the planer table.

6. Remove the dust hood, top cover, and belt cover.
7. Use a feeler gauge to adjust the table until there is a 0.040" gap between the wood blocks and a cutterhead knife at BDC, which is the recommended distance for the infeed roller below the cutterhead knife.
8. Lock the table in place, as the wood blocks will now be your reference point.
9. Using the feeler gauges and the wood blocks instead of the Rotacator, perform **Steps 8–14** in the previous **Using a Rotacator** procedure to set the feed rollers, chip breaker, and the pressure bar to the correct distance below the cutterhead knives.

Note: *Keep in mind that you will have to repeat **Steps 7–8** above for each change in distance as specified on **Page 40**.*



Roller Spring Tension

The infeed and outfeed rollers keep the workpiece moving through the planer. There are springs that exert downward pressure on the rollers while still allowing them to raise with an uneven workpiece surface. Properly roller spring tension is crucial to keep the workpiece moving through the planer during operation.

Roller spring tension will vary depending upon the type of wood you are planing. When adjusting the roller spring tension keep the following in mind:

- If you are planing milled lumber with a relatively consistent surface, use less spring tension.
- If you are planing rough lumber with inconsistent surfaces, use greater spring tension to keep the stock moving through the planer.
- If the workpiece consistently stops feeding during operation, the roller spring tension may need to be increased.

Tools Needed	Qty
Hex Wrench 6mm.....	1

To adjust the roller spring tension to factory recommendations:

1. DISCONNECT PLANER FROM POWER!
2. Adjust tension cap screws #1–#3 so that they protrude 1/8" above the head casting, and adjust cap screw #4 so that it protrudes 5/16" above the head casting (see **Figure 48**).

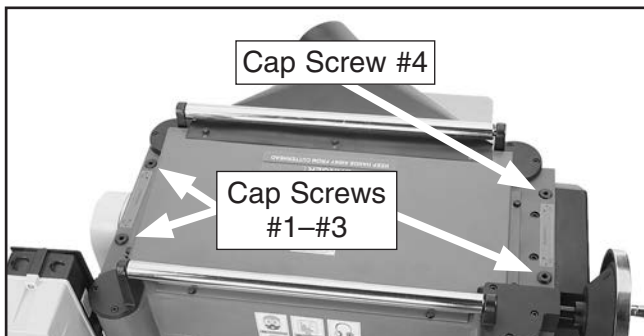

Figure 48. Roller spring tension adjustment cap screws.

Positioning Chip Deflector

Chip Deflector Gap Setting 1/4"

When properly distanced from the cutterhead, direct the chips into the dust hood, and keeps them from falling onto the outfeed roller and being pressed into the workpiece.

Tools Needed	Qty
Wrench or Socket 10mm.....	1
Fine Ruler or Calipers	1

To adjust the chip deflector gap:

1. DISCONNECT PLANER FROM POWER!
2. Remove the dust port, top cover, and belt cover.
3. Use the cutterhead pulley to rotate the cutterhead until a knife reaches the closest distance to the chip deflector (see **Figure 49**), then measure the distance between the knife and the chip deflector.

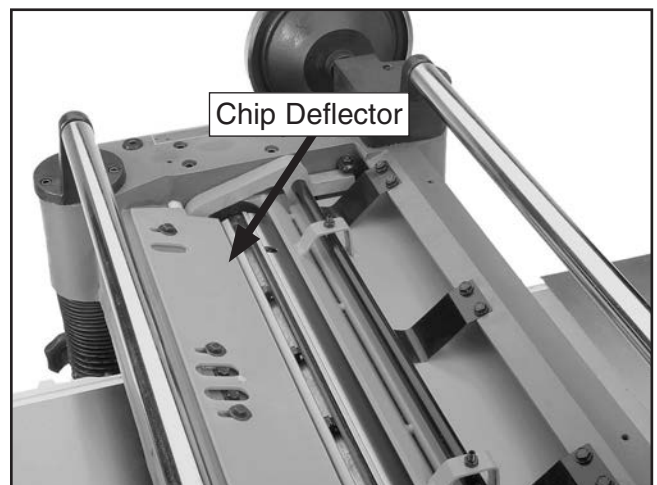

Figure 49. Chip deflector and securing hex bolts.



- If the distance measured in **Step 3** is not equal to $\frac{1}{4}$ ", then loosen the four hex bolts that secure the chip deflector and adjust the gap to $\frac{1}{4}$ ".
- Re-tighten the hex bolts, then replace the belt cover, top cover, and dust hood.

Scale Calibration

Although correctly set at the factory, the scale can be adjusted for accuracy if it becomes necessary.

Tools Needed	Qty
Phillips Screwdriver #2	1
Scrap Piece of Stock.....	1
Calipers	1

To re-position the scale:

- Plane the scrap piece of stock until it is flat and of even thickness along its length.

Note: Turn the board over between each pass.

- Use calipers to measure the board thickness.
- If there is a discrepancy between the board thickness and the reading on the table height scale, loosen the two screws shown in **Figure 50**, adjust the scale in relation to the pointer, then re-tighten the screws.

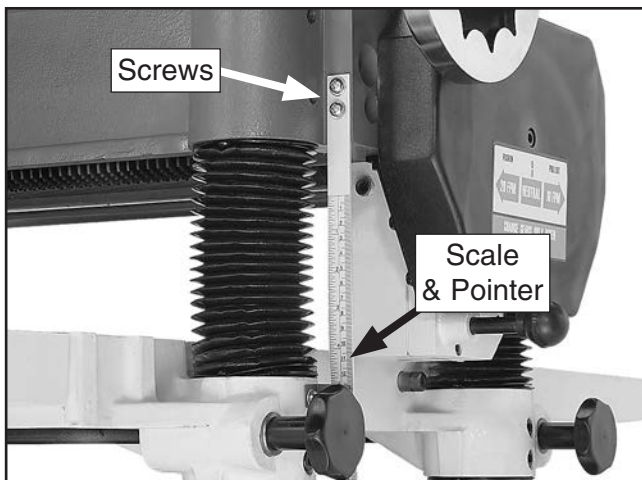

Figure 50. Table height scale.

Anti-Kickback Fingers

The anti-kickback fingers are an important safety feature of your planer. The fingers hang from a rod suspended across the head casting and in front of the infeed roller, as shown in **Figure 51**. This design allows the workpiece to easily enter the planer but reduces the risk of kickback by digging into the workpiece if it moves backward.

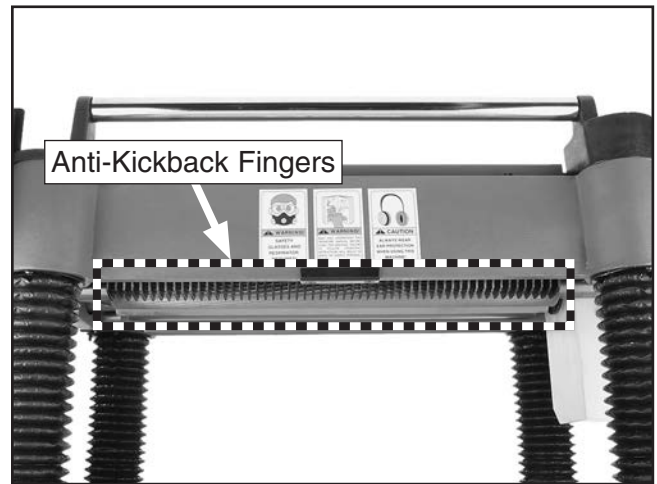

Figure 51. Anti-kickback fingers.

Check the anti-kickback fingers regularly to ensure they swing freely and easily. If the fingers do not swing freely and easily, first clean them with a wood resin solvent, then inspect them for damage. If any of the fingers are damaged, the device must be replaced before using the machine.

Do not apply oil or other lubricants to the anti-kickback fingers that will attract dust, and restrict the free movement of the fingers.

!WARNING

Proper operation of the anti-kickback fingers is critical for the safe operation of this planer. **DO NOT** operate the planer if the anti-kickback fingers are not operating correctly. Failure to heed this warning could result in serious personal injury.



Pulley Alignment

Proper pulley alignment prevents premature V-belt wear and unnecessary load on the motor. The pulleys are properly aligned when they are parallel and in the same plane as each other.

Tools Needed	Qty
Straightedge 3'	1
Hex Wrench 6mm.....	1
Wrenches or Sockets 14mm	1

To check/re-align pulleys:

1. DISCONNECT PLANER FROM POWER!
2. Remove both cabinet covers and the belt cover, then use the straightedge to check pulley alignment, as shown in **Figure 52**.



Figure 52. Checking pulley alignment.

—If the pulleys are not in the same plane, loosen the cap screw or hex bolt securing the pulley to the shaft, then adjust the pulleys in or out until they are aligned.

—If the pulleys are not parallel, loosen the four motor mount hex nuts, then rotate the motor on its mount until the pulleys are parallel.

3. Re-check the pulleys and repeat **Step 2** if necessary.
4. When you are satisfied with the pulley alignment, re-tighten all fasteners, then replace the belt cover and cabinet covers.



SECTION 8: WIRING

These pages are current at the time of printing. However, in the spirit of improvement, we may make changes to the electrical systems of future machines. Compare the manufacture date of your machine to the one stated in this manual, and study this section carefully.

If there are differences between your machine and what is shown in this section, call Technical Support at (570) 546-9663 for assistance BEFORE making any changes to the wiring on your machine. An updated wiring diagram may be available. **Note:** *Please gather the serial number and manufacture date of your machine before calling. This information can be found on the main machine label.*

WARNING

Wiring Safety Instructions

SHOCK HAZARD. Working on wiring that is connected to a power source is extremely dangerous. Touching electrified parts will result in personal injury including but not limited to severe burns, electrocution, or death. Disconnect the power from the machine before servicing electrical components!

MODIFICATIONS. Modifying the wiring beyond what is shown in the diagram may lead to unpredictable results, including serious injury or fire. This includes the installation of unapproved after-market parts.

WIRE CONNECTIONS. All connections must be tight to prevent wires from loosening during machine operation. Double-check all wires disconnected or connected during any wiring task to ensure tight connections.

CIRCUIT REQUIREMENTS. You MUST follow the requirements at the beginning of this manual when connecting your machine to a power source.

WIRE/COMPONENT DAMAGE. Damaged wires or components increase the risk of serious personal injury, fire, or machine damage. If you notice that any wires or components are damaged while performing a wiring task, replace those wires or components.

MOTOR WIRING. The motor wiring shown in these diagrams is current at the time of printing but may not match your machine. If you find this to be the case, use the wiring diagram inside the motor junction box.















CAPACITORS/INVERTERS. Some capacitors and power inverters store an electrical charge for up to 10 minutes after being disconnected from the power source. To reduce the risk of being shocked, wait at least this long before working on capacitors.

EXPERIENCING DIFFICULTIES. If you are experiencing difficulties understanding the information included in this section, contact our Technical Support at (570) 546-9663.

NOTICE

The photos and diagrams included in this section are best viewed in color. You can view these pages in color at www.grizzly.com.

COLOR KEY

BLACK 	BLUE 	YELLOW 	LIGHT BLUE 
WHITE 	BROWN 	YELLOW GREEN 	BLUE WHITE 
GREEN 	GRAY 	PURPLE 	TURQUOISE 
RED 	ORANGE 	PINK 	



G0453 Wiring Diagram

Magnetic ON/OFF Switch

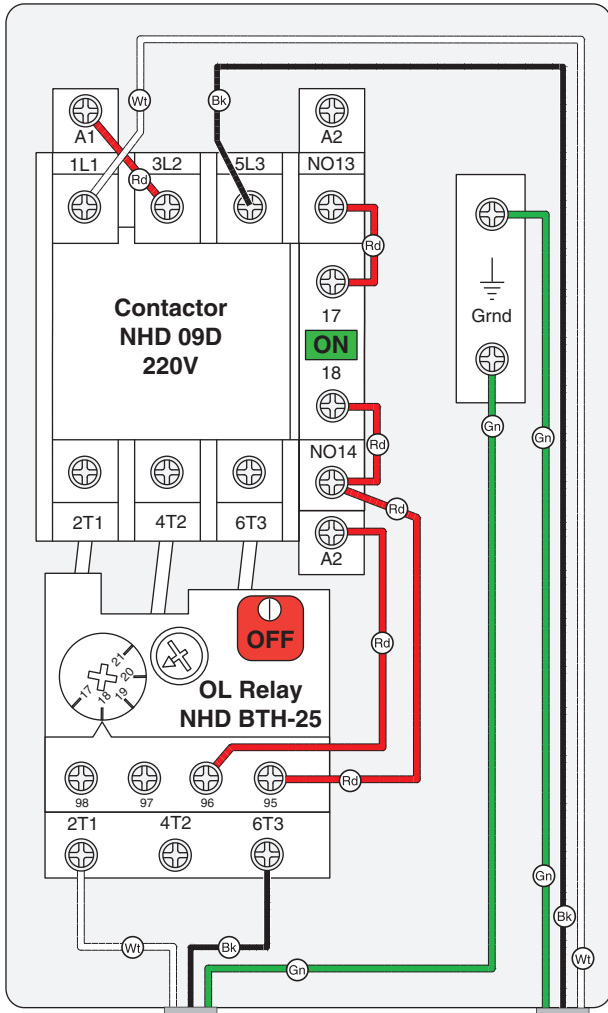

NOTICE

The motor wiring shown here is current at the time of printing, but it may not match your machine. Always use the wiring diagram inside the motor junction box.

NEMA 6-20 Plug (As Recommended)

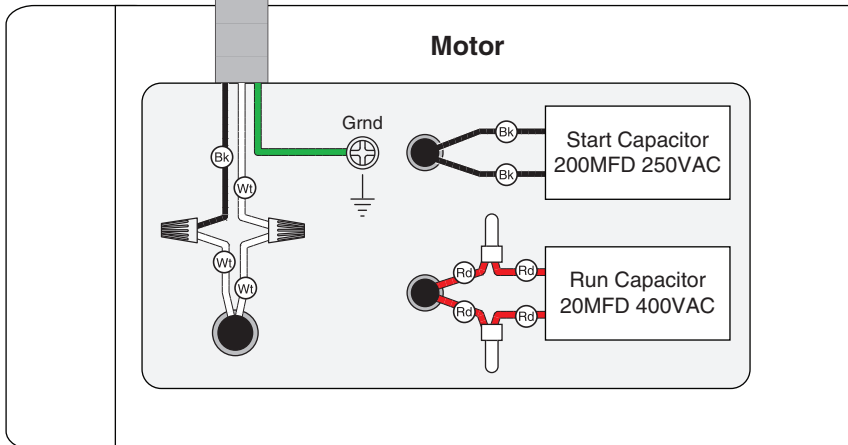
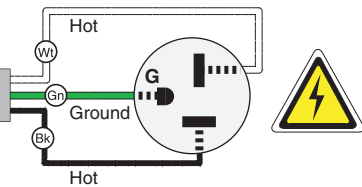

G0454 Wiring Diagram

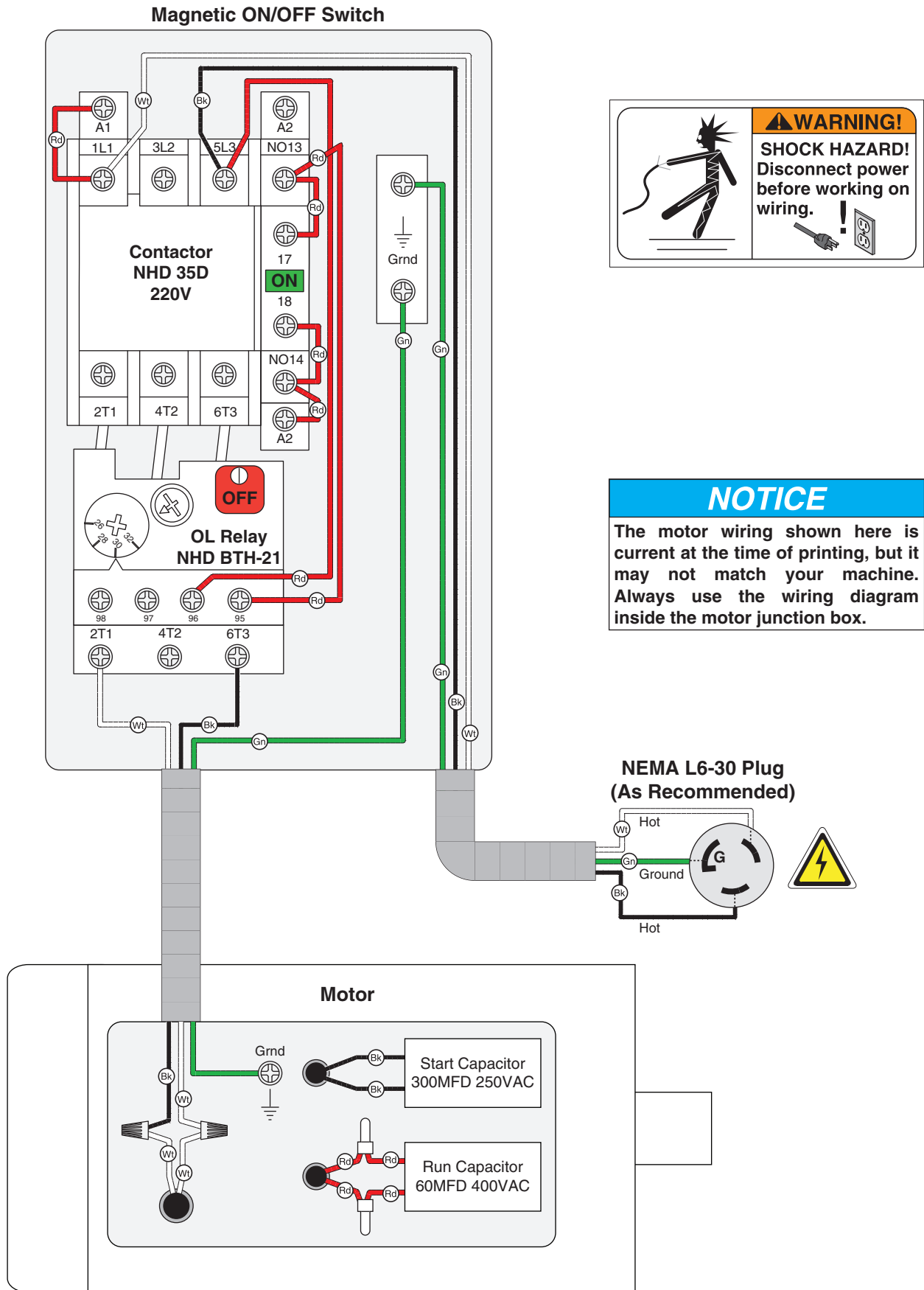

SECTION 9: PARTS

G0453 Headstock Breakdown

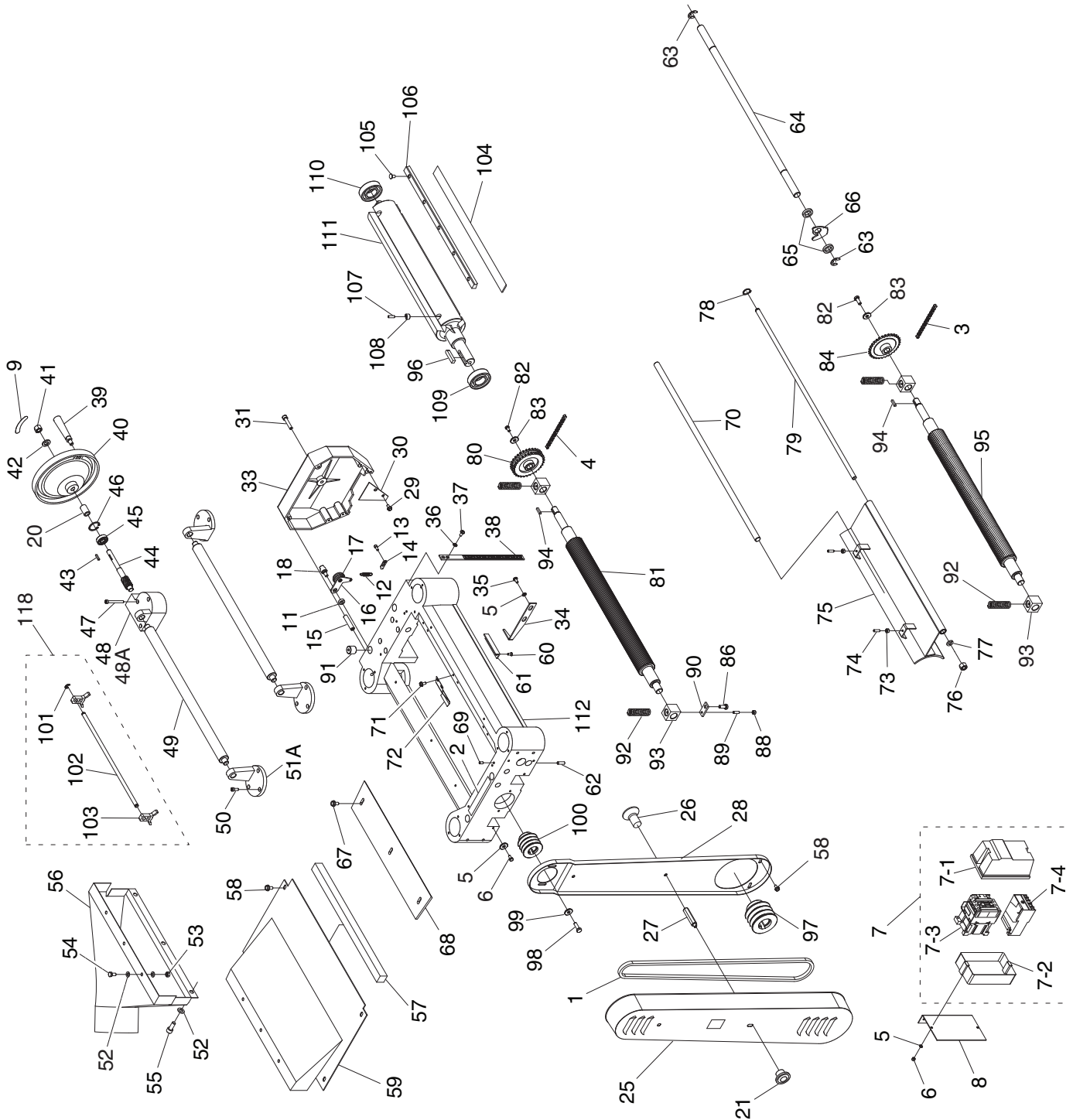

G0453 Headstock Parts List

REF	PART #	DESCRIPTION
1	P0453001	COGGED V-BELT MX-60
2	P0453002	OIL FILL LABEL
3	P0453003	CHAIN 06B-1 X 49 31LINKS
4	P0453004	CHAIN 06B-1 X 63 24LINKS
5	P0453005	FLAT WASHER 6MM
6	P0453006	CAP SCREW M6-1 X 12
7V2	P0453007V2	MAGNETIC SWITCH ASSEMBLY V2.01.11
7-1	P0453007-1	MAGNETIC SWITCH COVER ASSEMBLY
7-3	P0453007-3	CONTACTOR NHD C-09D 230V
7-4	P0453007-4	OL RELAY NHD NTH-21 17-21A
8	P0453008	MAGNETIC SWITCH PLATE
9	P0453009	HANDWHEEL LABEL
11	P0453011	IDLER BRACKET COLLAR
12	P0453012	EXTENSION SPRING
13	P0453013	CAP SCREW M6-1 X 8
14	P0453014	HANGER
15	P0453015	SHAFT
16	P0453016	BRACKET
17	P0453017	IDLER PULLEY
18	P0453018	IDLER MOUNTING SHAFT
20	P0453020	HANDWHEEL COLLAR
21	P0453021	STAR KNOB M8-1.25
25	P0453025	BELT COVER
26	P0453026	FLAT HD CAP SCR M6-1 X 16
27	P0453027	HEX STANDOFF
28	P0453028	BELT GUARD
29	P0453029	FLANGE BOLT M6-1 X 10
30	P0453030	SAFETY HATCH
31	P0453031	CAP SCREW M8-1.25 X 45
33	P0453033	CHAIN DRIVE COVER
34	P0453034	POINTER
35	P0453035	PHLP HD SCR M6-1 X 12
36	P0453036	FLAT WASHER 6MM
37	P0453037	PHLP HD SCR M6-1 X 12
38	P0453038	HANDWHEEL SCALE
39	P0453039	HANDWHEEL HANDLE
40	P0453040	HANDWHEEL
41	P0453041	HEX NUT M12-1.75
42	P0453042	FLAT WASHER 12MM
43	P0453043	KEY 4 X 4 X 20
44	P0453044	WORM GEAR
45	P0453045	BALL BEARING 6201ZZ
46	P0453046	INT RETAINING RING 32MM
47	P0453047	CAP SCREW M5-.8 X 55
48	P0453048	WORM HOUSING
48A	P0453048A	WORM HOUSING ASSEMBLY
49	P0453049	RETURN ROLLER
50	P0453050	CAP SCREW M5-.8 X 14
51A	P0453051A	ROLLER STAND 3.505" V2.01.08
52	P0453052	FLAT WASHER 6MM
53	P0453053	HEX NUT M6-1
54	P0453054	HEX BOLT M6-1 X 10
55	P0453055	CAP SCREW M8-1.25 X 20
56	P0453056	DUST HOOD
57	P0453057	FOAM PIECE

REF	PART #	DESCRIPTION
58	P0453058	FLANGE BOLT M6-1 X 10
59	P0453059	TOP COVER
60	P0453060	FLAT HD SCR M6-1 X 8
61	P0453061	CUT LIMIT PLATE
62	P0453062	SET SCREW M8-1.25 X 16
63	P0453063	E-CLIP 15MM
64	P0453064	ANTI-KICKBACK FINGER SHAFT
65	P0453065	ANTI-KICKBACK SHAFT COLLAR
66	P0453066	ANTI-KICKBACK FINGER
67	P0453067	FLANGE BOLT M6-1 X 12
68	P0453068	CHIP DEFLECTOR
69	P0453069	SET SCREW M6-1 X 20
70	P0453070	CHIP BREAKER SHAFT
71	P0453071	FLANGE BOLT M6-1 X 12
72	P0453072	HOLD DOWN PLATE
73	P0453073	HEX NUT M6-1
74	P0453074	SET SCREW M6-1 X 18
75	P0453075	CHIP BREAKER
76	P0453076	HEX NUT M12-1.75
77	P0453077	LOCK WASHER 12MM
78	P0453078	EXT RETAINING RING 12MM
79	P0453079	LOCKING ROD
80	P0453080	OUTFEED ROLLER SPROCKET
81	P0453081	OUTFEED ROLLER
82	P0453082	HEX BOLT M6-1 X 16
83	P0453083	FLAT WASHER 6MM
84	P0453084	INFEED ROLLER SPROCKET
86	P0453086	HEX BOLT M8-1.25 X 16
88	P0453088	HEX NUT M5-.8
89	P0453089	SET SCREW M5-.8 X 12
90	P0453090	PLATE
91	P0453091	OILER SET SCREW
92	P0453092	COMPRESSION SPRING
93	P0453093	ROLLER BUSHING BLOCK
94	P0453094	KEY 5 X 5 X 16
95	P0453095	INFEED ROLLER
96	P0453096	KEY 8 X 8 X 35
97	P0453097	MOTOR PULLEY MX
98	P0453098	HEX BOLT M8-1.25 X 20
99	P0453099	COLLAR
100	P0453100	CUTTERHEAD PULLEY MX
101	P0453101	E-CLIP 8MM
102	P0453102	KNIFE JIG SHAFT
103	P0453103	KNIFE JIG FOOT
104	P0453104	KNIVES 3-PC SET 15" X 1" X 1/8"
105	P0453105	GIB SCREW
106	P0453106	GIB
107	P0453107	JACK SCREW M5-.8 X 12
108	P0453108	ADJUSTING NUT
109	P0453109	BALL BEARING 6205ZZ
110	P0453110	BALL BEARING 6204ZZ
111	P0453111	KNIFE CUTTERHEAD 15"
112	P0453112	HEAD CASTING
118	P0453118	KNIFE SETTING JIG ASSEMBLY
119V2	P0453119V2	POWER CORD 12G 3W 72" 6-20P V2.08.12



G0453 Table Breakdown

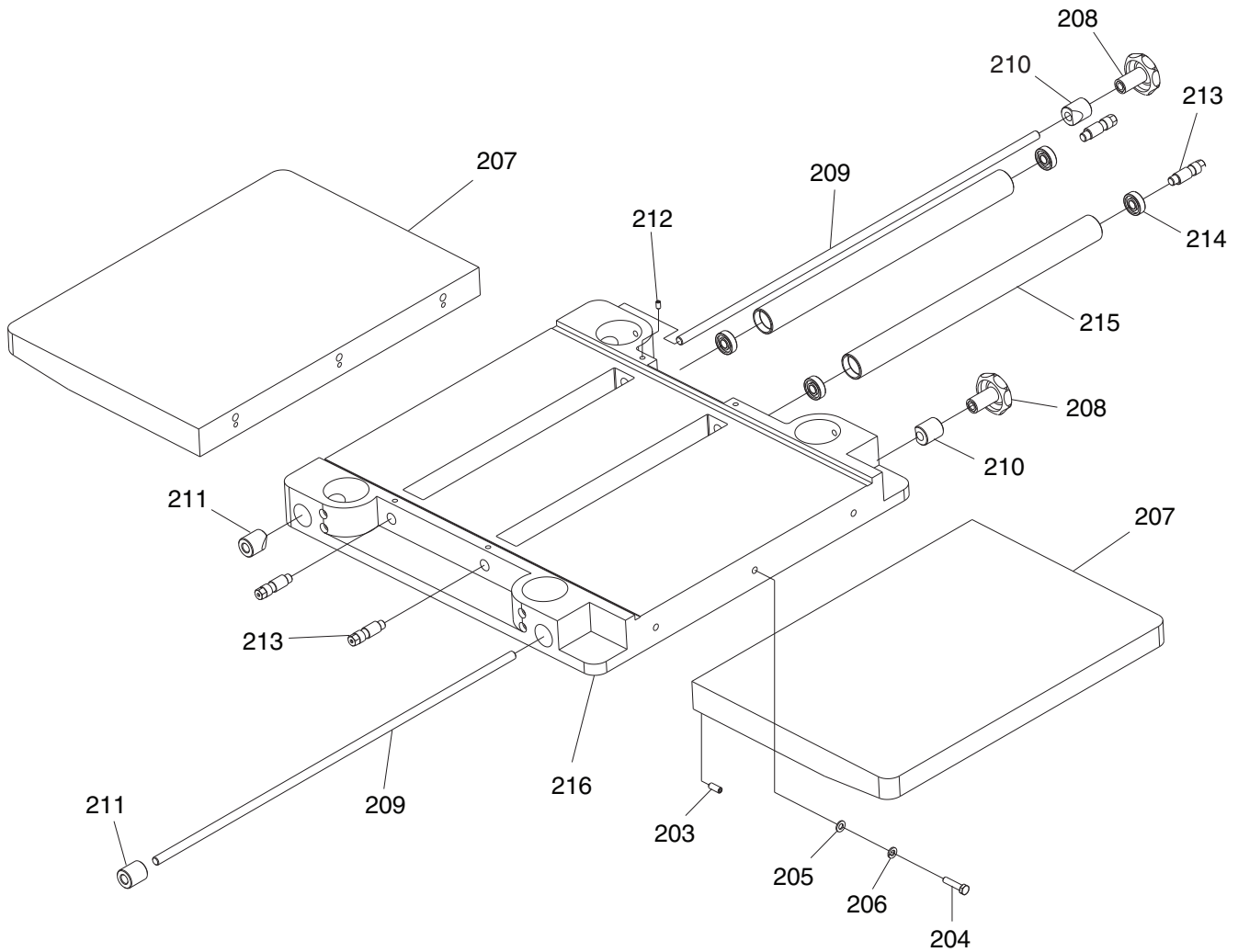

REF	PART #	DESCRIPTION
203	P0453203	SET SCREW M8-1.25 X 20
204	P0453204	HEX BOLT M8-1.25 X 30
205	P0453205	FLAT WASHER 8MM
206	P0453206	LOCK WASHER 8MM
207	P0453207	TABLE EXTENSION WING
208	P0453208	STAR KNOB M12-1.75
209	P0453209	LOCK BOLT

REF	PART #	DESCRIPTION
210	P0453210	GIB
211	P0453211	WEDGE DOG
212	P0453212	SET SCREW M6-1 X 16
213	P0453213	ECCENTRIC SHAFT
214	P0453214	BALL BEARING 608ZZ
215	P0453215	BED ROLLER
216	P0453216	MAIN TABLE



G0453 Columns Breakdown

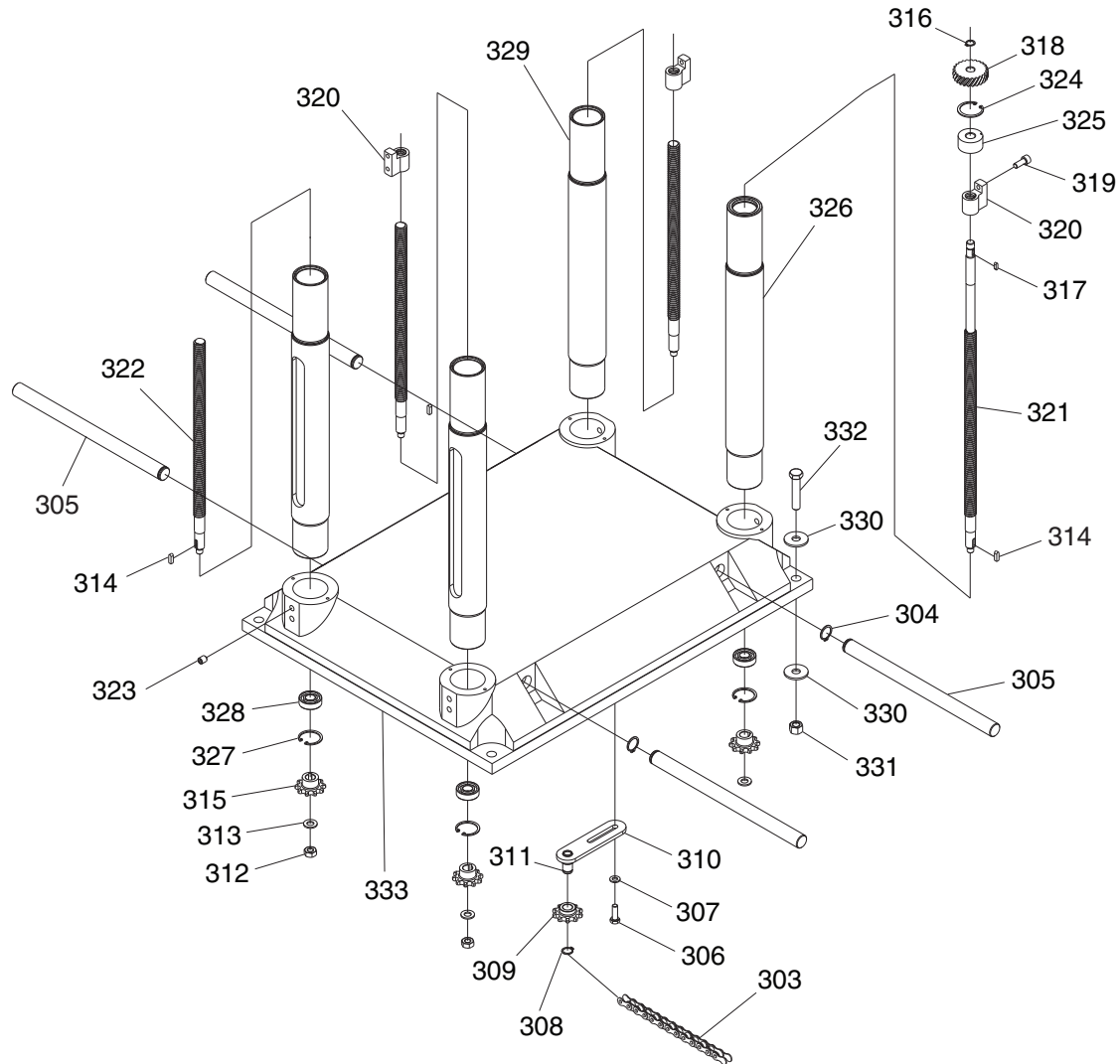

REF	PART #	DESCRIPTION
303	P0453303	CHAIN 12.7A X 134
304	P0453304	EXT RETAINING RING 15MM
305	P0453305	LIFTING BAR
306	P0453306	HEX BOLT M8-1.25 X 20
307	P0453307	FLAT WASHER 8MM
308	P0453308	EXT RETAINING RING 15MM
309	P0453309	SPROCKET
310A	P0453310A	SPROCKET BRACKET ASSEMBLY
312	P0453312	HEX NUT M10-1.5
313	P0453313	FLAT WASHER 10MM
314	P0453314	KEY 5 X 5 X 16
315	P0453315	SPROCKET
316	P0453316	EXT RETAINING RING 12MM
317	P0453317	KEY 4 X 4 X 12
318	P0453318	GEAR

REF	PART #	DESCRIPTION
319	P0453319	CAP SCREW M6-1 X 20
320	P0453320	LEADSCREW NUT
321	P0453321	PRIMARY LEADSCREW
322	P0453322	SECONDARY LEADSCREW
323	P0453323	SET SCREW M10-1.5 X 12
324	P0453324	INT RETAINING RING 40MM
325	P0453325	BUSHING
326	P0453326	PRIMARY COLUMN
327	P0453327	INT RETAINING RING 42MM
328	P0453328	BALL BEARING 6302ZZ
329	P0453329	SECONDARY COLUMN
330	P0453330	FLAT WASHER 12MM
331	P0453331	HEX NUT M12-1.75
332	P0453332	HEX BOLT M12-1.75 X 45
333	P0453333	BASE



G0453 Cabinet Stand Breakdown

For Machine Manufacture Date
Prior to 03/08

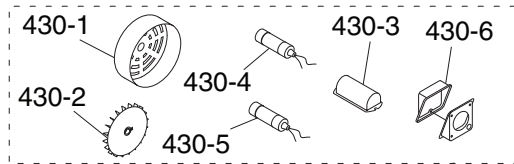

For Machine Manufacture Date
of 03/08 or After

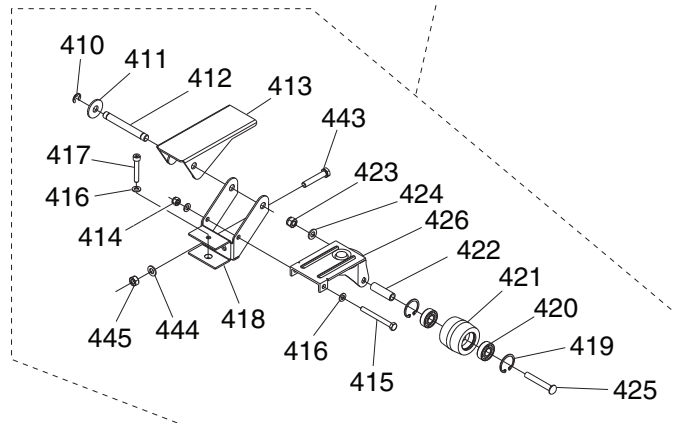
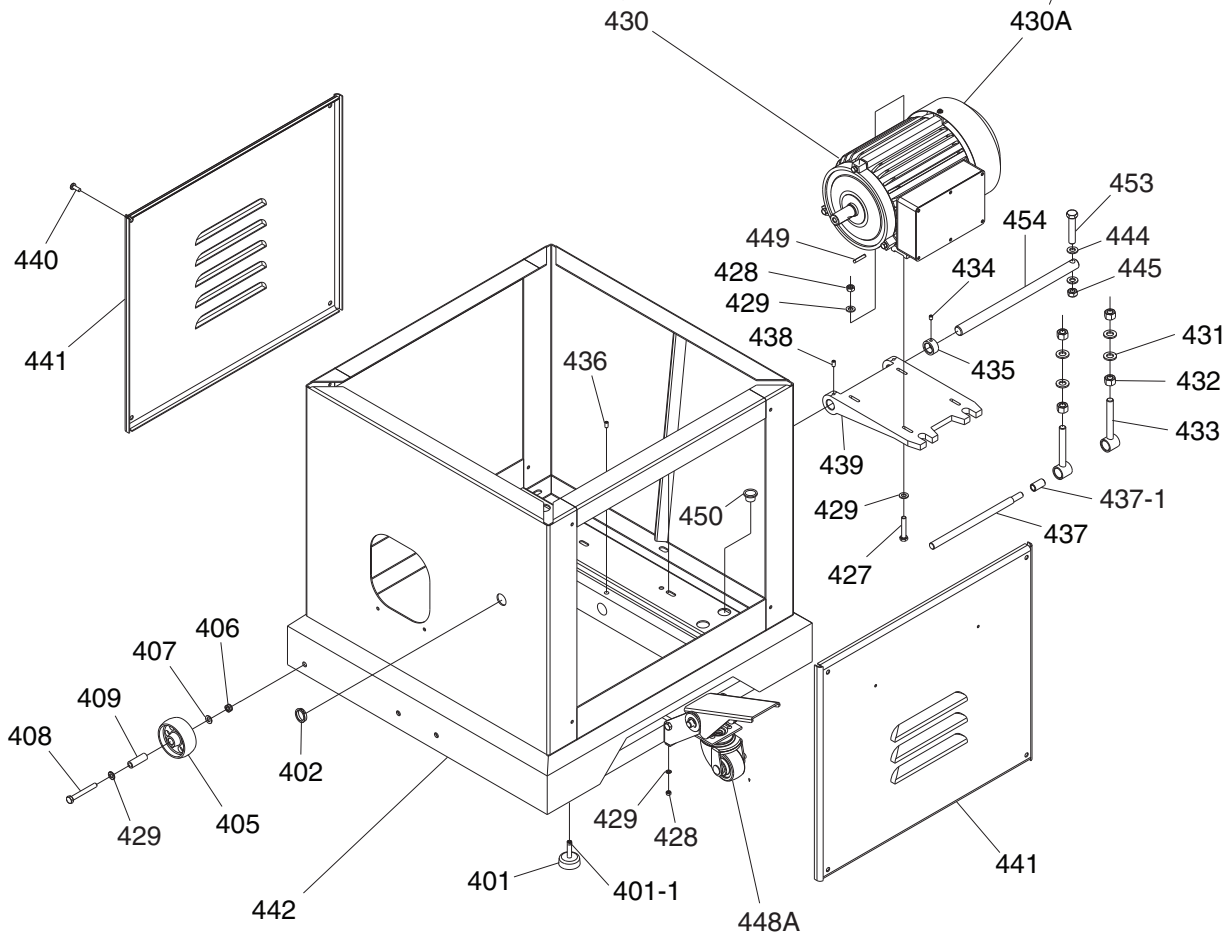
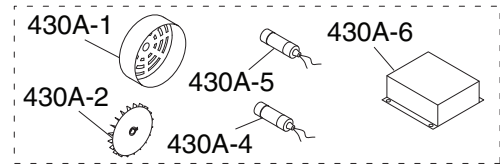

G0453 Cabinet Stand Parts List

REF	PART #	DESCRIPTION
401	P0453401	RUBBER FOOT
401-1	P0453401-1	HEX NUT M8-1.25
402	P0453402	PLASTIC GROMMET
405	P0453405	UNIVERSAL WHEEL 78MM DIA
406	P0453406	HEX NUT M8-1.25
407	P0453407	FLAT WASHER 8MM
408	P0453408	HEX BOLT M8-1.25 X 65
409	P0453409	SLEEVE
410	P0453410	EXT RETAINING RING 9MM
411	P0453411	FLAT WASHER 12MM
412	P0453412	SHAFT 12MM
413	P0453413	PEDAL
414	P0453414	HEX NUT M8-1.25
415	P0453415	HEX BOLT M8-1.25 X 100
416	P0453416	FLAT WASHER 8MM
417	P0453417	HEX BOLT M8-1.25 X 50
418	P0453418	BRACKET
419	P0453419	INT RETAINING RING 35MM
420	P0453420	BALL BEARING 6202-2RS
421	P0453421	TROLLEY WHEEL
422	P0453422	TROLLEY WHEEL SLEEVE
423	P0453423	LOCK NUT M12-1.75
424	P0453424	FLAT WASHER 10MM
425	P0453425	TROLLEY WHEEL BOLT
426	P0453426	TROLLEY UNIVERSAL KIT
427	P0453427	HEX BOLT M8-1.25 X 45
428	P0453428	HEX NUT M8-1.25
429	P0453429	FLAT WASHER 8MM
430A	P0453430A	MOTOR 3HP 240V 1-PH V2.03.08
430A-1	P0453430A-1	MOTOR FAN COVER V2.03.08

REF	PART #	DESCRIPTION
430A-2	P0453430A-2	MOTOR FAN V2.03.08
430A-4	P0453430A-4	R CAPACITOR 20M 400V V2.03.08
430A-5	P0453430A-5	S CAPACITOR 200M 250V V2.03.08
430A-6	P0453430A-6	JUNCTION BOX V2.03.08
430A-7	P0453430A-7	BALL BEARING 6205ZZ
430A-8	P0453430A-8	BALL BEARING 6203ZZ
430A-9	P0453430A-9	CENTRIFUGAL SWITCH 16MM 3450
430A-10	P0453430A-10	CONTACT PLATE 16MM
431	P0453431	FLAT WASHER 12MM
432	P0453432	HEX NUT M12-1.75
433	P0453433	ADJUST BOLT
434	P0453434	SET SCREW M6-1 X 8
435	P0453435	LOCK COLLAR
436	P0453436	SET SCREW M8-1.25 X 12
437	P0453437	PLATE CONNECTING ROD
437-1	P0453437-1	BUSHING
438	P0453438	SET SCREW M6-1 X 12
439	P0453439	MOTOR MOUNT PLATE
440	P0453440	PHLP HD SCR M6-1 X 20
441	P0453441	CABINET COVER
442	P0453442	CABINET STAND
443	P0453443	HEX BOLT M12-1.75 X 120
444	P0453444	FLAT WASHER 10MM
445	P0453445	HEX NUT M10-1.5
448A	P0453448A	PEDAL ASSEMBLY
449	P0453449	KEY 5 X 5 X 30
450	P0453450	BALL STRAIN RELIEF
453	P0453453	HEX BOLT M10-1.5 X 70
454	P0453454	PLATE CONNECTING ROD



G0453 Gearbox Breakdown

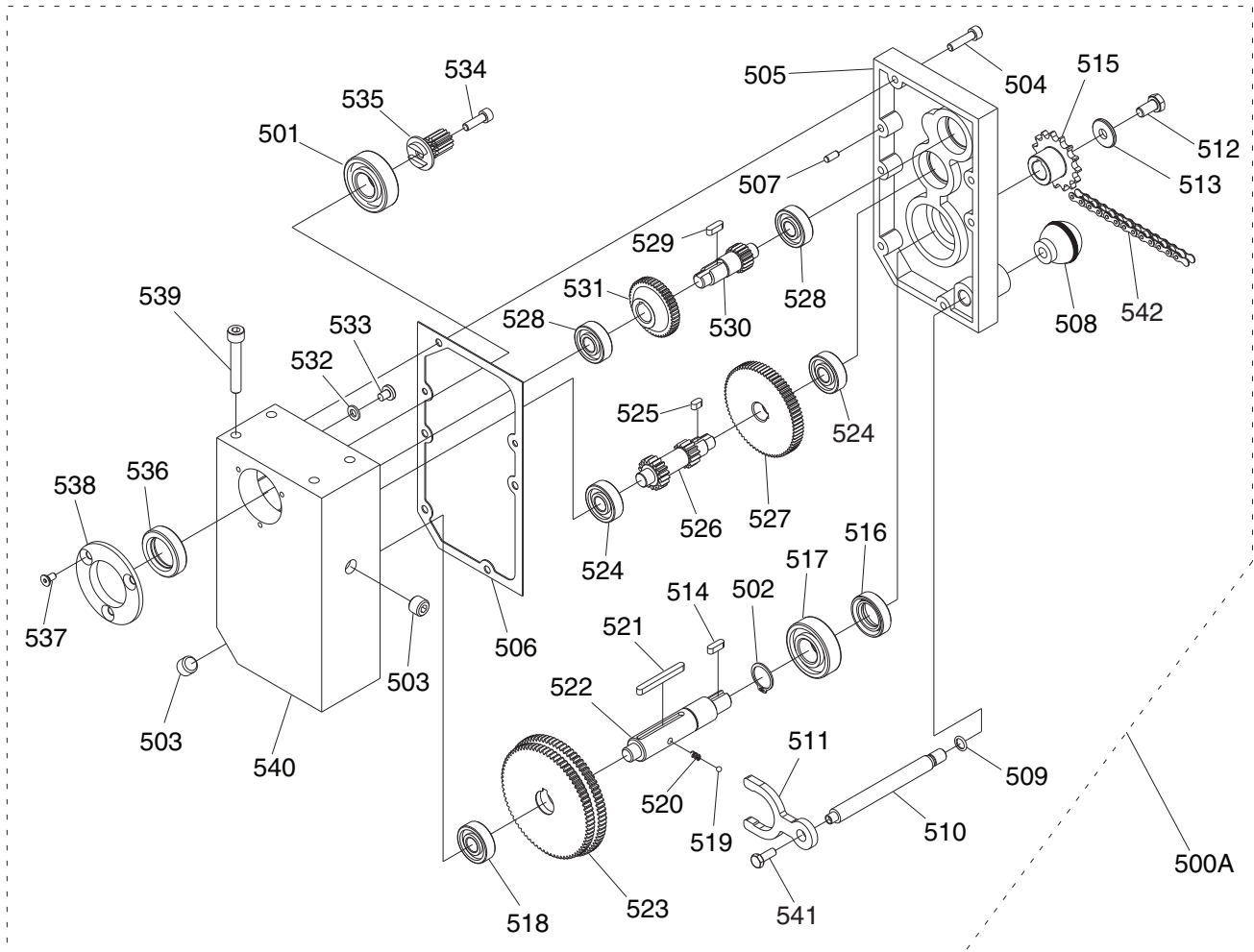

REF	PART #	DESCRIPTION
500A	P0453500A	GEARBOX ASSEMBLY
501	P0453501	BALL BEARING 6204ZZ
502	P0453502	EXT RETAINING RING 20MM
503	P0453503	OIL PLUG
504	P0453504	CAP SCREW M6-1 X 25
505	P0453505	GEARBOX BASE
506	P0453506	GASKET
507	P0453507	PIN 5 X 10
508	P0453508	BALL KNOB M10-1.5
509	P0453509	O-RING 10.8 X 2.4 P11
510	P0453510	HANDLE SHAFT
511	P0453511	SHIFTING FORK
512	P0453512	HEX BOLT M8-1.25 X 16
513	P0453513	FLAT WASHER 8MM
514	P0453514	KEY 5 X 5 X 16
515	P0453515	SPROCKET
516	P0453516	OIL SEAL 20 X 35 X 7
517	P0453517	BALL BEARING 6204ZZ
518	P0453518	BALL BEARING 6201ZZ
519	P0453519	STEEL BALL 4MM
520	P0453520	COMPRESSION SPRING
521	P0453521	KEY 5 X 5 X 50

REF	PART #	DESCRIPTION
522	P0453522	SHAFT
523	P0453523	GEAR
524	P0453524	BALL BEARING 6201ZZ
525	P0453525	KEY 5 X 5 X 10
526	P0453526	GEAR SHAFT
527	P0453527	GEAR
528	P0453528	BALL BEARING 6201ZZ
529	P0453529	KEY 5 X 5 X 14
530	P0453530	GEAR SHAFT
531	P0453531	GEAR
532	P0453532	FLAT WASHER 6MM
533	P0453533	PHLP HD SCR M6-1 X 8
534	P0453534	CAP SCREW M6-1.0 X 20 LH
535	P0453535	GEAR 14T
536	P0453536	OIL SEAL 25 X 40 X 10
537	P0453537	CAP SCREW M5-.8 X 12
538	P0453538	FLANGE COVER
539	P0453539	CAP SCREW M8-1.25 X 50
540	P0453540	GEARBOX COVER
541	P0453541	FLANGE BOLT M6-1 X 12
542	P0453542	CHAIN 06B-1 X 49



G0453 Label Placement

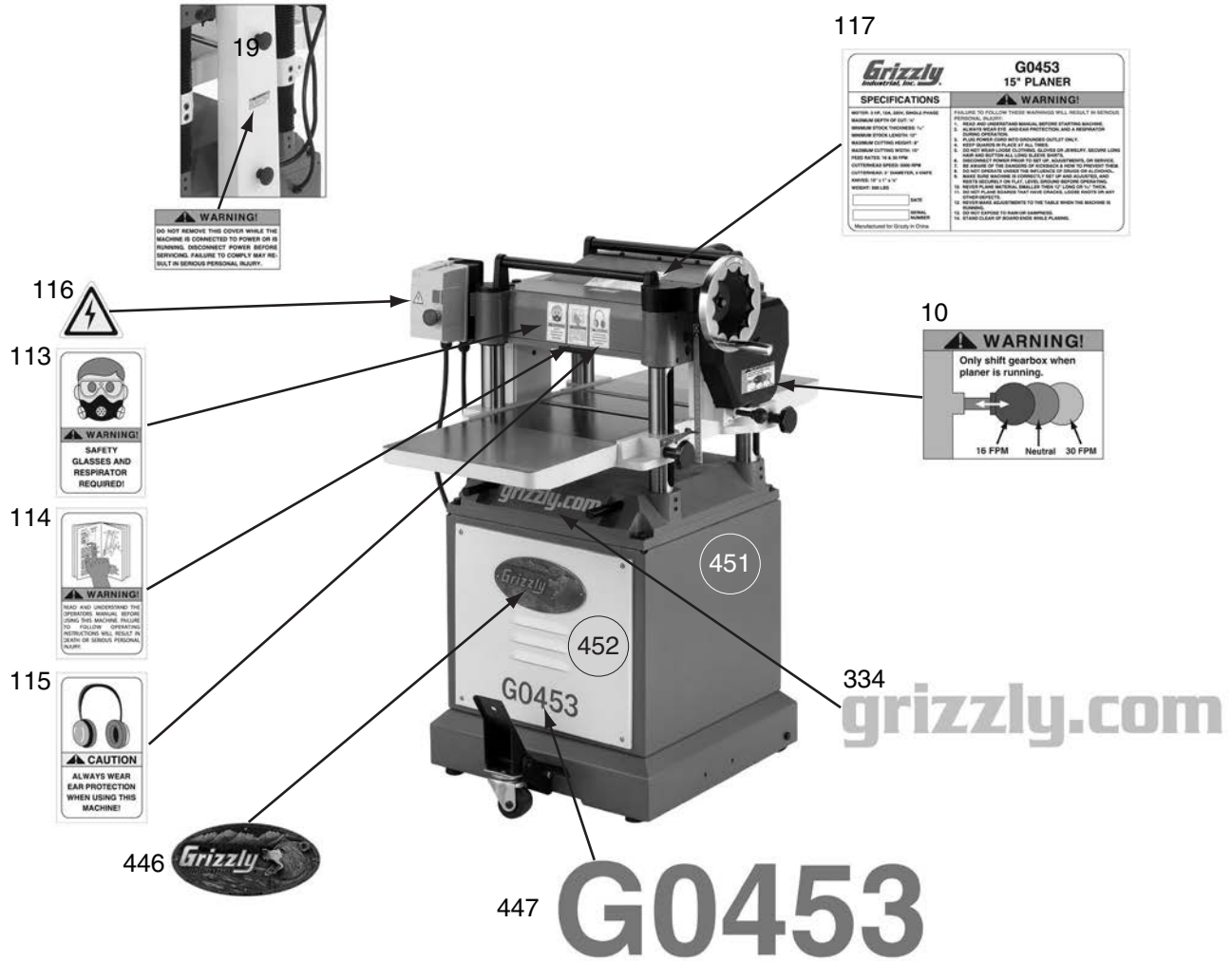

REF	PART #	DESCRIPTION
10	P0453010	SPEED CHANGE LABEL
19	P0453019	BELT COVER LABEL
113	P0453113	RESPIRATOR/GLASSES LABEL VL
114	P0453114	READ MANUAL LABEL VL
115	P0453115	EAR PROTECTION LABEL VL
116	P0453116	ELECTRICITY LABEL

REF	PART #	DESCRIPTION
117V2	P0453117V2	MACHINE ID LABEL CSA V2.08.12
334	P0453334	GRIZZLY.COM LABEL 10 X 1-1/2"
446	P0453446	GRIZZLY NAMEPLATE
447	P0453447	MODEL NUMBER LABEL
451	P0453451	GRIZZLY GREEN TOUCH UP PAINT
452	P0453452	GRIZZLY PUTTY TOUCH UP PAINT

⚠️ WARNING

Safety labels warn about machine hazards and ways to prevent injury. The owner of this machine **MUST** maintain the original location and readability of the labels on the machine. If any label is removed or becomes unreadable, **REPLACE** that label before using the machine again. Contact Grizzly at (800) 523-4777 or www.grizzly.com to order new labels.



G0454 Headstock Breakdown

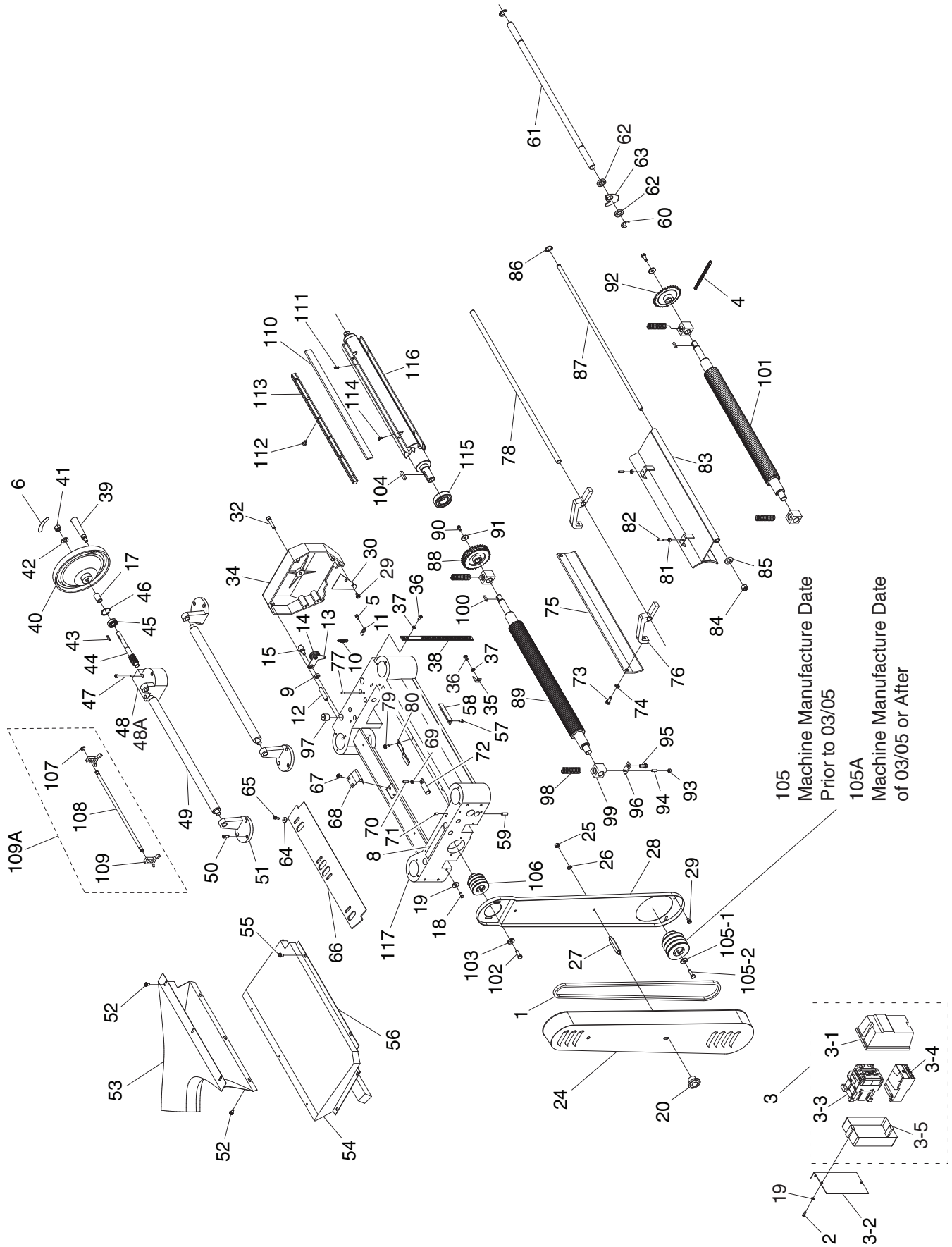

G0454 Headstock Parts List

REF	PART #	DESCRIPTION
1	P0454001	COGGED V-BELT MX-60
2	P0454002	CAP SCREW M6-1 X 12
3V2	P0454003V2	MAG SWITCH ASSEMBLY V2.01.11
3-1	P0454003-1	MAG SWITCH FRONT COVER
3-2	P0454003-2	MAG SWITCH BRACKET
3-3	P0454003-3	CONTACTOR NHD C-35D 220V
3-4V2	P0454003-4V2	OL RELAY NHD NTH-32 28-32A V2.08.12
3-5	P0454003-5	MAG SWITCH REAR COVER
4	P0454004	CHAIN 06B-1 X 67
5	P0454005	CAP SCREW M6-1 X 10
6	P0454006	HANDWHEEL LABEL
8	P0454008	OIL LEVEL LABEL
9	P0454009	IDLER BRACKET COLLAR
10	P0454010	EXTENSION SPRING
11	P0454011	HANGER
12	P0454012	ROLL PIN 6 X 20
13	P0454013	BRACKET
14	P0454014	IDLER PULLEY
15	P0454015	IDLER MOUNTING SHAFT
17	P0454017	HANDWHEEL COLLAR
18	P0454018	HEX BOLT M6-1 X 12
19	P0454019	FLAT WASHER 6MM
20	P0454020	STAR KNOB M8-1.25
24	P0454024	BELT COVER
25	P0454025	HEX NUT M8-1.25
26	P0454026	FLAT WASHER 8MM
27	P0454027	HEX STANDOFF
28	P0454028	BELT GUARD
29	P0454029	FLANGE BOLT M6-1 X 10
30	P0454030	SAFETY HATCH
32	P0454032	CAP SCREW M8-1.25 X 40
34	P0454034	CHAIN DRIVE COVER
35	P0454035	CUT LIMITER POINTER
36	P0454036	PHLP HD SCR M6-1 X 12
37	P0454037	FLAT WASHER 6MM
38	P0454038	HANDWHEEL SCALE
39	P0454039	HANDLE
40	P0454040	HANDWHEEL
41	P0454041	HEX NUT M12-1.75
42	P0454042	FLAT WASHER 12MM
43	P0454043	KEY 4 X 4 X 20
44	P0454044	WORM GEAR
45	P0454045	BALL BEARING 6201ZZ
46	P0454046	INT RETAINING RING 32MM
47	P0454047	CAP SCREW M5-.8 X 55

REF	PART #	DESCRIPTION
48A	P0454048A	WORM HOUSING ASSEMBLY
49	P0454049	RETURN ROLLER
50	P0454050	CAP SCREW M6-1 X 16
51	P0454051	ROLLER STAND
52	P0454052	FLANGE BOLT M6-1 X 12
53	P0454053	DUST HOOD
54	P0454054	TOP COVER GASKET
55	P0454055	FLANGE BOLT M6-1 X 12
56	P0454056	TOP COVER
57	P0454057	HEX BOLT M5-.8 X 12
58	P0454058	CUT LIMIT PLATE
59	P0454059	SET SCREW M8-1.25 X 12
60	P0454060	E-CLIP 15MM
61	P0454061	ANTI-KICKBACK FINGER SHAFT
62	P0454062	ANTI-KICKBACK SHAFT COLLAR
63	P0454063	ANTI-KICKBACK FINGER
64	P0454064	FLAT WASHER 6MM
65	P0454065	FLANGE BOLT M6-1 X 15
66	P0454066	CHIP DEFLECTOR PLATE
67	P0454067	FLANGE BOLT M6-1 X 12
68	P0454068	HOLD DOWN PLATE
69	P0454069	HEX NUT M6-1
70	P0454070	SET SCREW M6-1 X 20
71	P0454071	SET SCREW M6-1 X 12
72	P0454072	ADJUSTING SHAFT
73	P0454073	HEX BOLT M8-1.25 X 20
74	P0454074	LOCK WASHER 8MM
75	P0454075	PRESSURE BAR
76	P0454076	CHIP BREAKER BRACKET
77	P0454077	SET SCREW M6-1 X 16
78	P0454078	PRESSURE PLATE SHAFT
79	P0454079	FLANGE BOLT M6-1 X 12
80	P0454080	PLATE SPRING
81	P0454081	HEX NUT M6-1
82	P0454082	SET SCREW M6-1 X 20
83	P0454083	CHIP BREAKER
84	P0454084	HEX NUT M12-1.75
85	P0454085	LOCK WASHER 12MM
86	P0454086	EXT RETAINING RING 12MM
87	P0454087	LOCK ROD
88	P0454088	OUTFEED ROLLER SPROCKET
89	P0454089	OUTFEED ROLLER
90	P0454090	HEX BOLT M6-1 X 16
91	P0454091	FLAT WASHER 6MM



G0454 Headstock Parts List

REF	PART #	DESCRIPTION
92	P0454092	INFEED ROLLER SPROCKET
93	P0454093	HEX NUT M6-1
94	P0454094	SET SCREW M6-1 X 20
95	P0454095	HEX BOLT M8-1.25 X 20
96	P0454096	ADJUSTMENT PLATE
97	P0454097	OILER SET SCREW
98	P0454098	COMPRESSION SPRING
99	P0454099	FEED ROLLER BLOCK
100	P0454100	KEY 5 X 5 X 22
101	P0454101	INFEED ROLLER
102	P0454102	HEX BOLT M8-1.25 X 25
103	P0454103	CUTTER PULLEY FLAT WASHER
104	P0454104	KEY 8 X 8 X 35
105A	P0454105A	MOTOR PULLEY MX V2.09.07
105-1	P0454105-1	MOTOR PULLEY WASHER
105-2	P0454105-2	TAPERED HEAD SCREW

REF	PART #	DESCRIPTION
105A	P0454105A	MOTOR PULLEY MX V2.09.07
106	P0454106	CUTTERHEAD PULLEY MX
107	P0454107	E-CLIP 8MM
108	P0454108	KNIFE JIG SHAFT
109	P0454109	KNIFE JIG FOOT
109A	P0454109A	KNIFE SETTING JIG ASSEMBLY
110	P0454110	KNIVES 20" X 1" X 1/8" 4-PC SET
111	P0454111	COMPRESSION SPRING
112	P0454112	GIB SCREW
113	P0454113	GIB
114	P0454114	JACK SCREW M5-.8 X 12
115	P0454115	BALL BEARING 6206ZZ
116	P0454116	CUTTERHEAD 20" 4-KNIFE
117	P0454117	HEAD CASTING
124V2	P0454124V2	POWER CORD 12G 3W 72" L6-30P V2.08.12



G0454 Table Breakdown

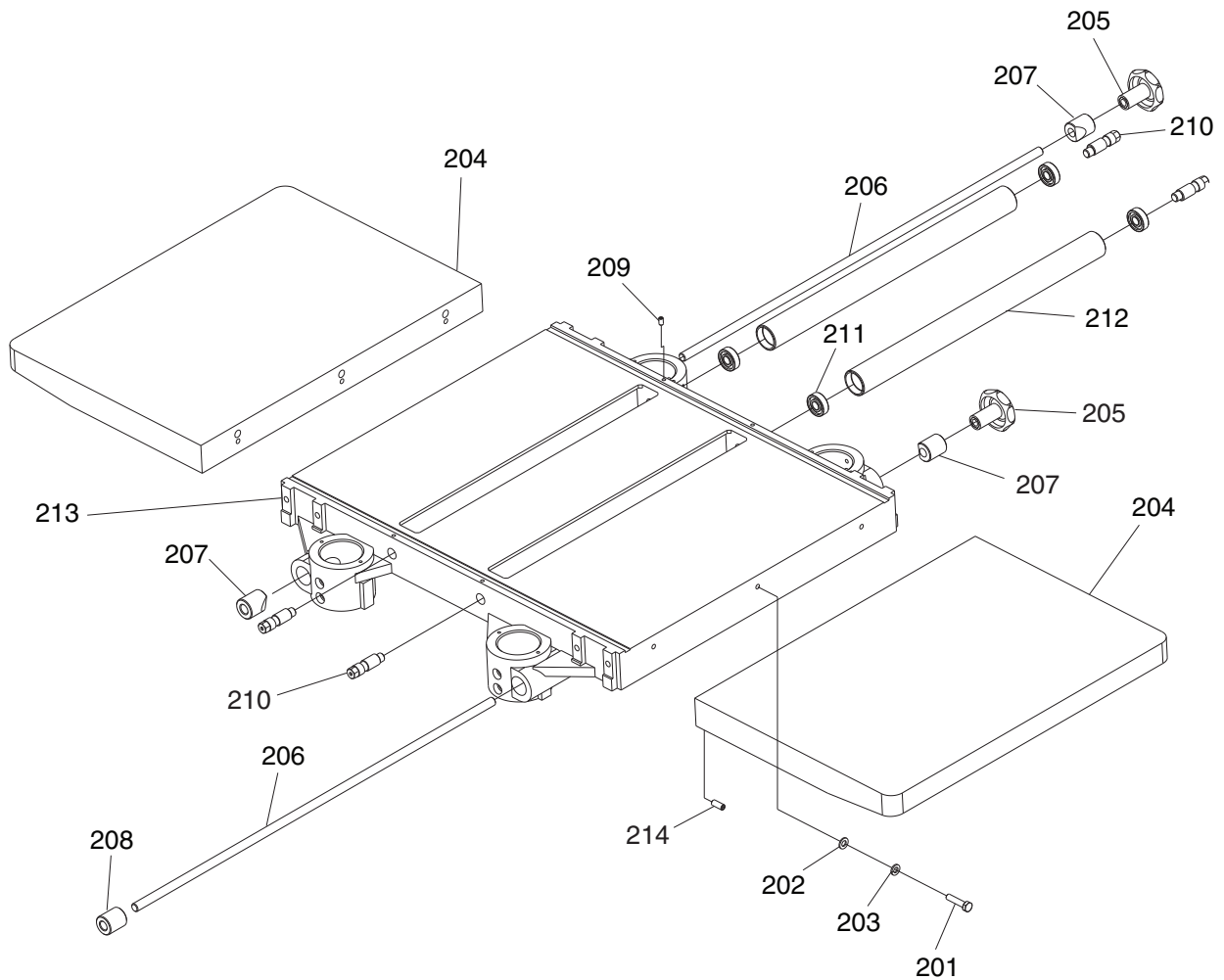

REF	PART #	DESCRIPTION
201	P0454201	HEX BOLT M8-1.25 X 35
202	P0454202	FLAT WASHER 8MM
203	P0454203	LOCK WASHER 8MM
204	P0454204	EXTENSION WING
205	P0454205	STAR KNOB M12-1.75
206	P0454206	LOCK ROD
207	P0454207	GIB

REF	PART #	DESCRIPTION
208	P0454208	WEDGE DOG
209	P0454209	SET SCREW M6-1 X 12
210	P0454210	ECCENTRIC SHAFT
211	P0454211	BALL BEARING 6201ZZ
212	P0454212	BED ROLLER
213	P0454213	MAIN TABLE
214	P0454214	SET SCREW M8-1.25 X 20



G0454 Columns Breakdown

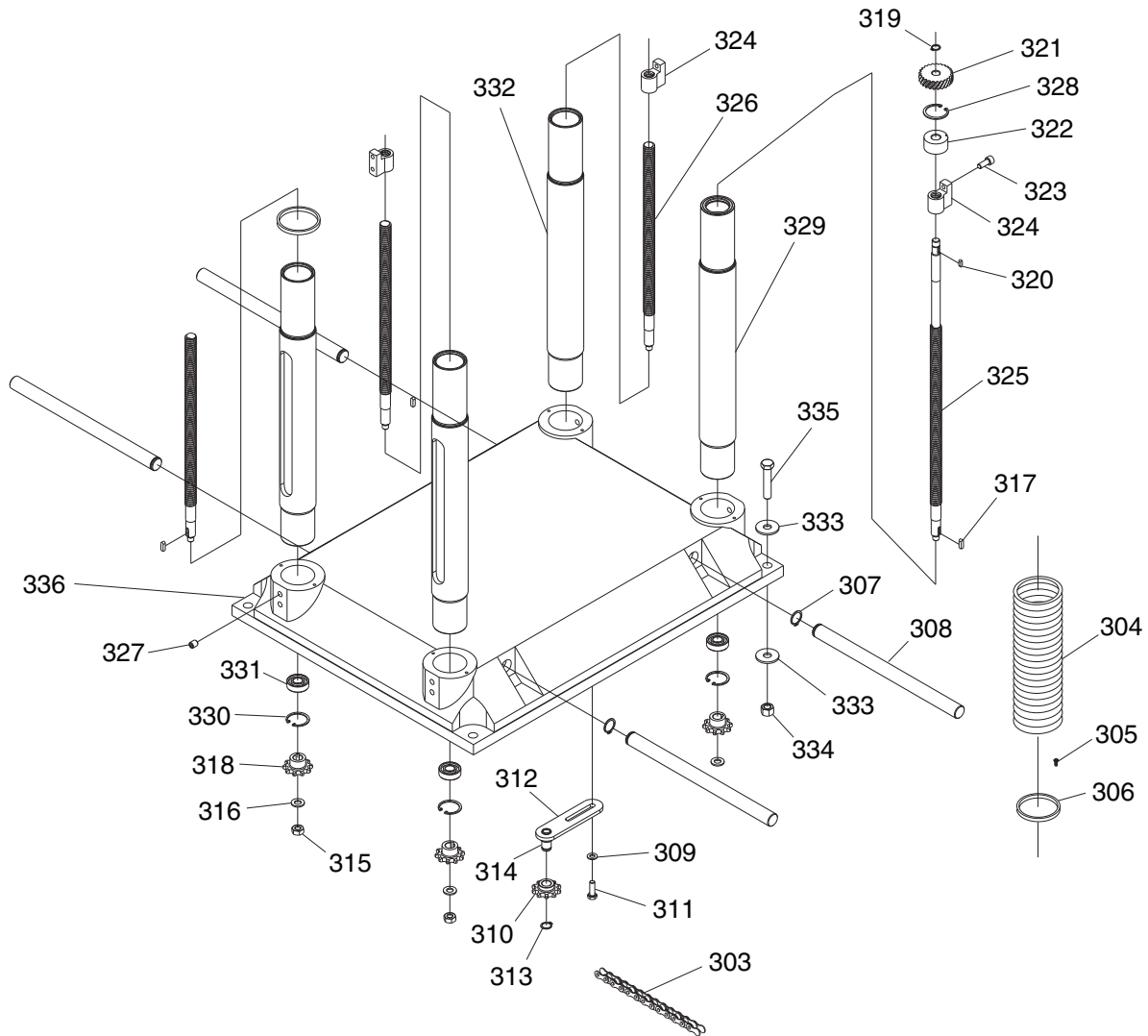

REF	PART #	DESCRIPTION
303	P0454303	CHAIN 08A-1 X 66
304	P0454304	DUST BOOT
305	P0454305	PHLP HD SCR M5-.8 X 10
306	P0454306	DUST BOOT SEAL
307	P0454307	EXT RETAINING RING 5MM
308	P0454308	LIFTING BAR
309	P0454309	FLAT WASHER 8MM
310	P0454310	SPROCKET
311	P0454311	HEX BOLT M8-1.25 X 25
312	P0454312	BRACKET
313	P0454313	EXT RETAINING RING 15MM
314	P0454314	SHAFT
315	P0454315	HEX NUT M10-1.5
316	P0454316	FLAT WASHER 10MM
317	P0454317	KEY 5 X 5 X 16
318	P0454318	SPROCKET
319	P0454319	EXT RETAINING RING 12MM

REF	PART #	DESCRIPTION
320	P0454320	KEY 4 X 4 X 12
321	P0454321	GEAR
322	P0454322	BUSHING
323	P0454323	CAP SCREW M8-1.25 X 20
324	P0454324	LEADSCREW NUT
325	P0454325	PRIMARY LEADSCREW
326	P0454326	SECONDARY LEADSCREW
327	P0454327	SET SCREW M10-1.5 X 12
328	P0454328	INT RETAINING RING 38MM
329	P0454329	PRIMARY COLUMN
330	P0454330	INT RETAINING RING 35MM
331	P0454331	BALL BEARING 6202ZZ
332	P0454332	SECONDARY COLUMN
333	P0454333	FLAT WASHER 12MM
334	P0454334	HEX NUT M12-1.75
335	P0454335	HEX BOLT M12-1.75 X 60
336	P0454336	BASE



G0454 Cabinet Stand Breakdown

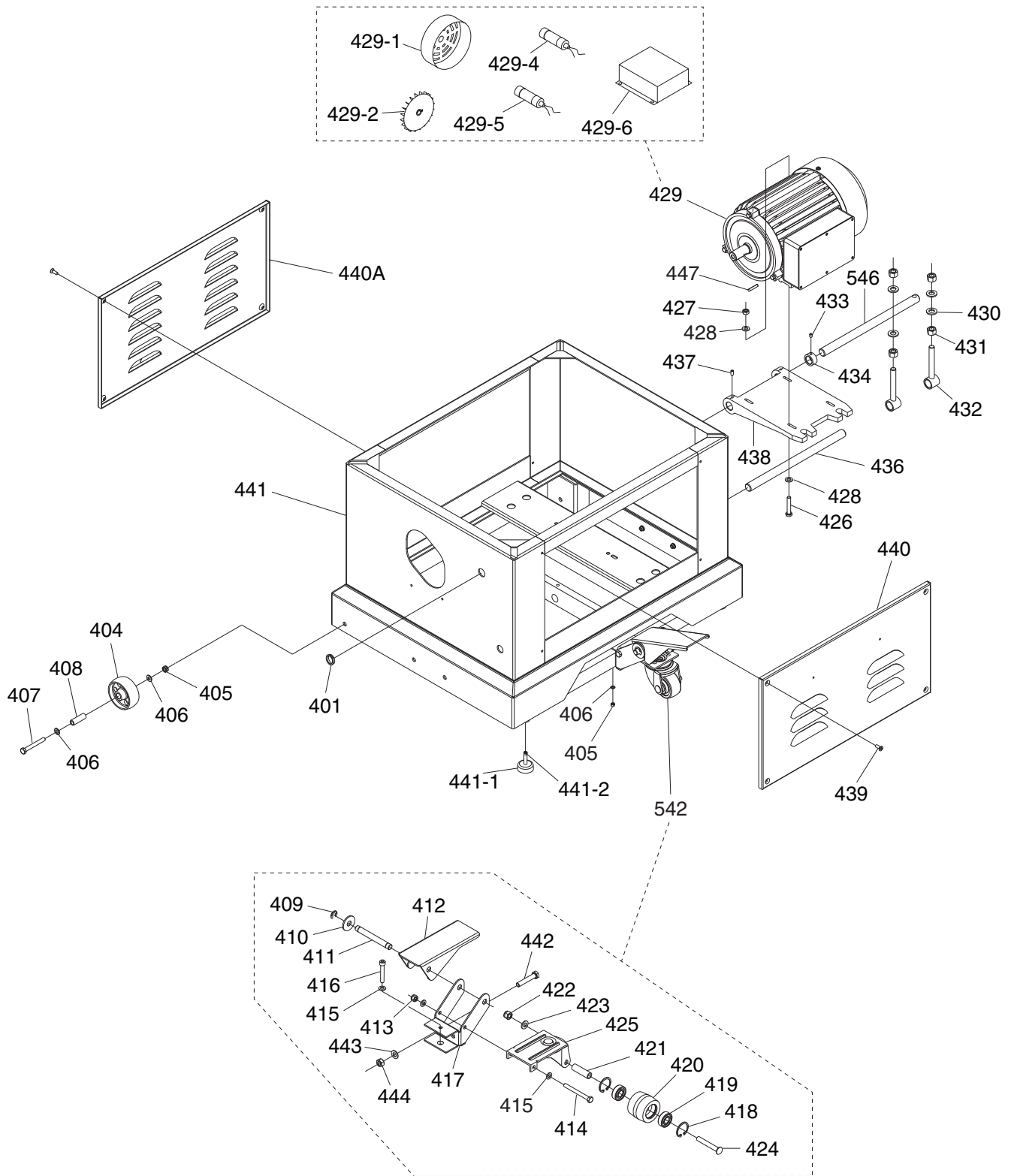

G0454 Cabinet Stand Parts List

REF	PART #	DESCRIPTION
401	P0454401	RELIEF BUSHING
404	P0454404	UNIVERSAL WHEEL 78MM DIA
405	P0454405	HEX NUT M8-1.25
406	P0454406	FLAT WASHER 8MM
407	P0454407	HEX BOLT M8-1.25 X 65
408	P0454408	SLEEVE
409	P0454409	E-CLIP 9MM
410	P0454410	FLAT WASHER 12MM
411	P0454411	SHAFT 12MM
412	P0454412	PEDAL
413	P0454413	HEX NUT M8-1.25
414	P0454414	HEX BOLT M8-1.25 X 100
415	P0454415	FLAT WASHER 8MM
416	P0454416	HEX BOLT M8-1.25 X 50
417	P0454417	BRACKET
418	P0454418	INT RETAINING RING 35MM
419	P0454419	BALL BEARING 6202-2RS
420	P0454420	TROLLEY WHEEL
421	P0454421	TROLLEY WHEEL SLEEVE
422	P0454422	LOCK NUT M12-1.75
423	P0454423	FLAT WASHER 10MM
424	P0454424	TROLLEY WHEEL BOLT
425	P0454425	TROLLEY UNIVERSAL KIT
426	P0454426	HEX BOLT M8-1.25 X 45
427	P0454427	HEX NUT M8-1.25
428	P0454428	FLAT WASHER 8MM
429	P0454429	MOTOR 5HP 240V 1-PH
429-1	P0454429-1	MOTOR FAN COVER

REF	PART #	DESCRIPTION
429-2	P0454429-2	MOTOR FAN
429-4	P0454429-4	S CAPACITOR 300M 250V
429-5	P0454429-5	R CAPACITOR 60M 450V
429-6	P0454429-6	MOTOR WIRING JUNCTION BOX
429-7	P0454429-7	BALL BEARING 6206ZZ
429-8	P0454429-8	BALL BEARING 6204ZZ
429-9	P0454429-9	CENTRIFUGAL SWITCH 19MM 3450
429-10	P0454429-10	CONTACT PLATE 19MM
430	P0454430	FLAT WASHER 12MM
431	P0454431	HEX NUT M12-1.75
432	P0454432	ADJUST BOLT
433	P0454433	SET SCREW M6-1 X 8
434	P0454434	CONNECTING ROD LOCK COLLAR
436	P0454436	PLATE CONNECTING ROD
437	P0454437	SET SCREW M6-1 X 12
438	P0454438	MOTOR MOUNT PLATE
439	P0454439	FLAT HD SCR M6-1 X 20
440	P0454440	FRONT COVER
440A	P0454440A	REAR COVER
441	P0454441	CABINET STAND
441-1	P0454441-1	HEX NUT M8-1.25
441-2	P0454441-2	RUBBER FOOT
442	P0454442	HEX BOLT M10-1.5 X 55
443	P0454443	FLAT WASHER 10MM
444	P0454444	HEX NUT M10-1.5
447	P0454447	KEY 5 X 5 X 30
542	P0454542	PEDAL ASSEMBLY
546	P0454546	PLATE CONNECTING ROD



G0454 Gearbox Breakdown

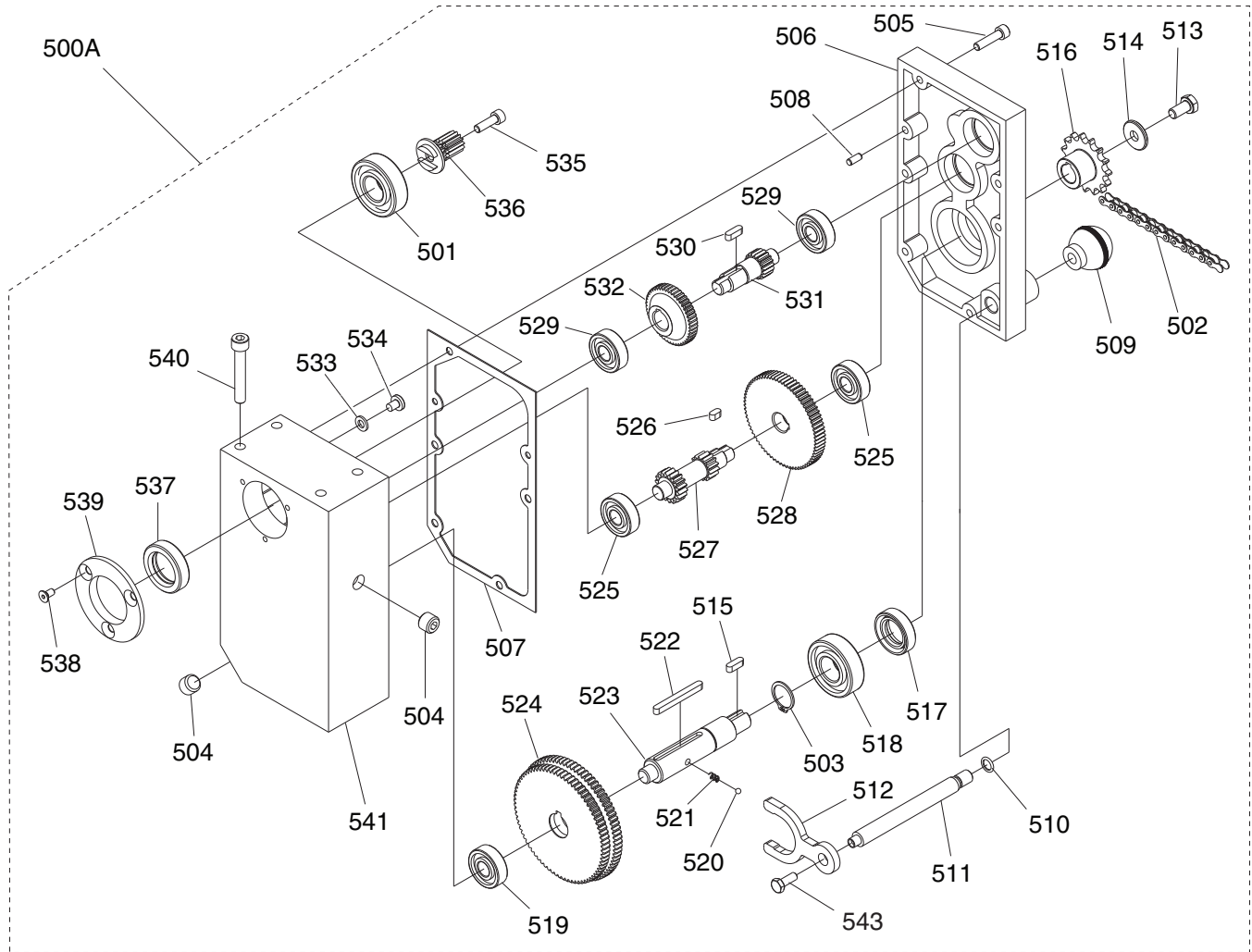

REF	PART #	DESCRIPTION
500A	P0454500A	GEARBOX ASSEMBLY
501	P0454501	BALL BEARING 6204ZZ
502	P0454502	CHAIN 06B-1 X 51
503	P0454503	EXT RETAINING RING 20MM
504	P0454504	OIL PLUG
505	P0454505	CAP SCREW M6-1 X 25
506	P0454506	GEARBOX BASE
507	P0454507	GASKET
508	P0454508	PIN 5 X 10
509	P0454509	BALL KNOB M10-1.5
510	P0454510	O-RING 10.8 X 2.4 P11
511	P0454511	HANDLE SHAFT
512	P0454512	SHIFTING FORK
513	P0454513	HEX BOLT M8-1.25 X 16
514	P0454514	FLAT WASHER 8MM
515	P0454515	KEY 5 X 5 X 16
516	P0454516	SPROCKET
517	P0454517	OIL SEAL 20 X 35 X 7
518	P0454518	BALL BEARING 6204ZZ
519	P0454519	BALL BEARING 6201ZZ
520	P0454520	STEEL BALL 4MM
521	P0454521	COMPRESSION SPRING

REF	PART #	DESCRIPTION
522	P0454522	KEY 5 X 5 X 50
523	P0454523	SHAFT
524	P0454524	GEAR
525	P0454525	BALL BEARING 6201ZZ
526	P0454526	KEY 5 X 5 X 10
527	P0454527	GEAR SHAFT
528	P0454528	GEAR
529	P0454529	BALL BEARING 6201ZZ
530	P0454530	KEY 5 X 5 X 14
531	P0454531	GEAR SHAFT
532	P0454532	GEAR
533	P0454533	FLAT WASHER 6MM
534	P0454534	PHLP HD SCR M6-1 X 8
535	P0454535	CAP SCREW M6-1.0 X 20 LH
536	P0454536	GEAR 14T
537	P0454537	OIL SEAL 25 X 40 X 10
538	P0454538	CAP SCREW M5-.8 X 12
539	P0454539	FLANGE COVER
540	P0454540	CAP SCREW M8-1.25 X 50
541	P0454541	GEARBOX COVER
543	P0454543	FLANGE BOLT M6-1 X 12



G0454 Label Placement



REF	PART #	DESCRIPTION
7	P0454007	SPEED CHANGE LABEL
16	P0454016	BELT COVER LABEL
118	P0454118	RESPIRATOR/GLASSES LABEL VL
119	P0454119	READ MANUAL LABEL VL
120	P0454120	EAR PROTECTION LABEL VL
121	P0454121	ELECTRICITY LABEL

REF	PART #	DESCRIPTION
122V2	P0454122V2	MACHINE ID LABEL CSA V2.08.12
337	P0454337	GRIZZLY.COM LABEL 13 X 2"
445	P0454445	GRIZZLY NAMEPLATE
446	P0454446	MODEL NUMBER LABEL
544	P0454544	GRIZZLY GREEN TOUCH UP PAINT
545	P0454545	GRIZZLY PUTTY TOUCH UP PAINT

⚠️ WARNING

Safety labels warn about machine hazards and ways to prevent injury. The owner of this machine **MUST** maintain the original location and readability of the labels on the machine. If any label is removed or becomes unreadable, **REPLACE** that label before using the machine again. Contact Grizzly at (800) 523-4777 or www.grizzly.com to order new labels.







WARRANTY CARD

Name _____
 Street _____
 City _____ State _____ Zip _____
 Phone # _____ Email _____
 Model # _____ Order # _____ Serial # _____

The following information is given on a voluntary basis. It will be used for marketing purposes to help us develop better products and services. **Of course, all information is strictly confidential.**

1. How did you learn about us?

Advertisement Friend Catalog
 Card Deck Website Other:

2. Which of the following magazines do you subscribe to?

<input type="checkbox"/> Cabinetmaker & FDM	<input type="checkbox"/> Popular Science	<input type="checkbox"/> Wooden Boat
<input type="checkbox"/> Family Handyman	<input type="checkbox"/> Popular Woodworking	<input type="checkbox"/> Woodshop News
<input type="checkbox"/> Hand Loader	<input type="checkbox"/> Precision Shooter	<input type="checkbox"/> Woodsmith
<input type="checkbox"/> Handy	<input type="checkbox"/> Projects in Metal	<input type="checkbox"/> Woodwork
<input type="checkbox"/> Home Shop Machinist	<input type="checkbox"/> RC Modeler	<input type="checkbox"/> Woodworker West
<input type="checkbox"/> Journal of Light Cont.	<input type="checkbox"/> Rifle	<input type="checkbox"/> Woodworker's Journal
<input type="checkbox"/> Live Steam	<input type="checkbox"/> Shop Notes	<input type="checkbox"/> Other:
<input type="checkbox"/> Model Airplane News	<input type="checkbox"/> Shotgun News	
<input type="checkbox"/> Old House Journal	<input type="checkbox"/> Today's Homeowner	
<input type="checkbox"/> Popular Mechanics	<input type="checkbox"/> Wood	

3. What is your annual household income?

\$20,000-\$29,000 \$30,000-\$39,000 \$40,000-\$49,000
 \$50,000-\$59,000 \$60,000-\$69,000 \$70,000+

4. What is your age group?

20-29 30-39 40-49
 50-59 60-69 70+

5. How long have you been a woodworker/metalworker?

0-2 Years 2-8 Years 8-20 Years 20+ Years

6. How many of your machines or tools are Grizzly?

0-2 3-5 6-9 10+

7. Do you think your machine represents a good value? Yes No

8. Would you recommend Grizzly Industrial to a friend? Yes No

9. Would you allow us to use your name as a reference for Grizzly customers in your area?

Note: We never use names more than 3 times. Yes No

10. Comments: _____

CUT ALONG DOTTED LINE

FOLD ALONG DOTTED LINE



Place
Stamp
Here



GRIZZLY INDUSTRIAL, INC.
P.O. BOX 2069
BELLINGHAM, WA 98227-2069



FOLD ALONG DOTTED LINE

Send a Grizzly Catalog to a friend:

Name _____
Street _____
City _____ State _____ Zip _____

TAPE ALONG EDGES--PLEASE DO NOT STAPLE

WARRANTY AND RETURNS

Grizzly Industrial, Inc. warrants every product it sells for a period of **1 year** to the original purchaser from the date of purchase. This warranty does not apply to defects due directly or indirectly to misuse, abuse, negligence, accidents, repairs or alterations or lack of maintenance. This is Grizzly's sole written warranty and any and all warranties that may be implied by law, including any merchantability or fitness, for any particular purpose, are hereby limited to the duration of this written warranty. We do not warrant or represent that the merchandise complies with the provisions of any law or acts unless the manufacturer so warrants. In no event shall Grizzly's liability under this warranty exceed the purchase price paid for the product and any legal actions brought against Grizzly shall be tried in the State of Washington, County of Whatcom.

We shall in no event be liable for death, injuries to persons or property or for incidental, contingent, special, or consequential damages arising from the use of our products.

To take advantage of this warranty, contact us by mail or phone and give us all the details. We will then issue you a "Return Number," which must be clearly posted on the outside as well as the inside of the carton. We will not accept any item back without this number. Proof of purchase must accompany the merchandise.

The manufacturers reserve the right to change specifications at any time because they constantly strive to achieve better quality equipment. We make every effort to ensure that our products meet high quality and durability standards and we hope you never need to use this warranty.

Please feel free to write or call us if you have any questions about the machine or the manual.

Thank you again for your business and continued support. We hope to serve you again soon.

grizzly.com[®]
TOOL WEBSITE

Buy Direct and Save with Grizzly[®] – Trusted, Proven and a Great Value!
~Since 1983~

*Visit Our Website Today For
Current Specials!*

**ORDER
24 HOURS A DAY!
1-800-523-4777**

