

INSTRUCTIONS FOR C1331 CORNER LOCK MITER BIT

Grizzly

Industrial, Inc.®

⚠ WARNING

- Failure to follow these guidelines will result in serious personal injury.
- ALWAYS WEAR ANSI APPROVED EYE AND EAR PROTECTION WHEN USING THIS BIT.
- The use of a router table is strongly recommended.
- Never feed lumber with the rotation of the bit.
- Follow the safety guidelines set forth by the manufacturer of the router and router table.

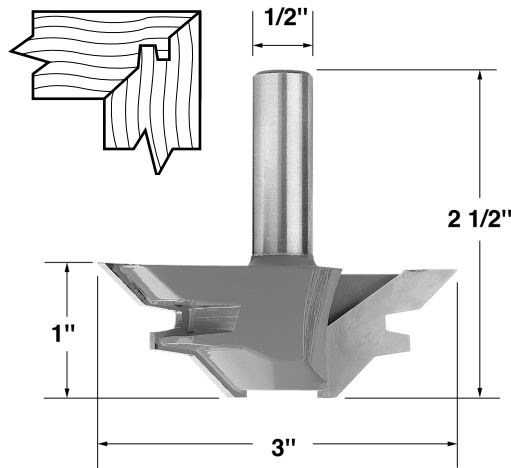

⚠ CAUTION

These router bits have sharp edges. Use care while removing the waxy protective coating. Never turn on the router with the protective coating still on the bit.

The Model C1331 Corner Lock Miter Bit offers a convenient method for creating a tight-locking, easily glued 90° corner joint in materials ranging from 9/16" to 1" wide. The large cutting surface and cutter diameter require a moderate degree of power and control. We recommend using this bit in a router table, with a router rated at 1 1/4 horsepower or larger, particularly when used with hardwoods and thicker materials.

Note: These instructions and drawings are intended for explanation and clarification purposes only as they relate to this particular router bit. Apply all safety rules and measures pertaining to router operations and your specific operation. Refer to the owner's manual supplied with your router and router table for specific warnings and instructions before proceeding with equipment operations.

⚠ WARNING

- Unplug Router before installing or adjusting cutter.
- Keep all guards and anti-kick-back devices in place.
- Double check bit to insure it is tight and secure in spindle.
- Always inspect lumber and other wood materials for cracks, knots, or other imperfections that could cause lumber to kick or shatter while milling.

Step 1 – Vertical Cut

It is recommended that an auxiliary fence be used to help support the workpiece during the routing process.

Adjust the router bit in the router table until the center of the lock notches are roughly half the height of your material off the surface of the router table. Determine which side of your material you want on the inside and what you want on the outside of your 90°

PUSH BLOCK

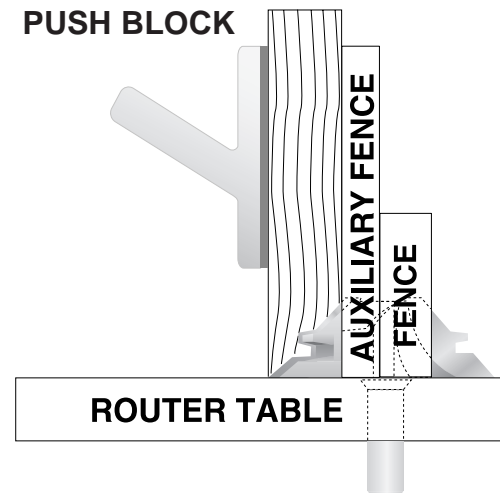

joint and place the inside surface against the fence. Adjust the fence so the bit's cutting height matches the thickness of the material you are cutting. Use a length of scrap lumber to make a test cut.

Step 2 – Horizontal Cut

Place another test board flat against the router table and make another test cut, as shown in the figure to the right. Place the two cuts together and adjust bit height and fence location until your test joints fit smoothly and precisely. Once you are satisfied with your test results, make your cuts with your actual project materials.

